

MOS INTEGRATED CIRCUIT

μ PD30700, 30700L, 30710

VR10000™, VR12000™ 64-BIT MICROPROCESSORS

DESCRIPTION

The μ PD30700 and 30700L (VR10000) and μ PD30710 (VR12000) are new members of NEC's VR series™ RISC (Reduced Instruction Set Computer) microprocessors. These new high-performance 64-bit microprocessors employ a new RISC architecture developed by MIPS™, ANDES™ architecture.

The VR10000 and VR12000 are designed to be used in high-performance computers and achieve considerably higher processing speed through the employment of a super scalar pipeline.

Remark ANDES: Architecture with Non-sequential Dynamic Execution Scheduling

The functions of these microprocessors are described in detail in the following manuals. Be sure to read these manuals when designing systems.

VR10000, VR12000 User's Manual : U10278E

VR5000™, VR10000 User's Manual - Instruction : U12754E

FEATURES

- MIPS 64-bit RISC architecture
- High-speed operation processing
 - Super scalar pipeline executing five instructions in parallel
- <VR10000>
 - 14SPECint95, 23SPECfp95
- <VR12000>
 - 17SPECint95, 27SPECfp95
- Instruction set upward-compatible with VR4000™, VR4200™, and VR4400™ (conforms to MIPS-I/II/III/IV)
- High-speed translation lookaside buffer (TLB) (64 double entries)
- Address space Physical: 40 bits
Virtual: 44 bits
- Floating-point unit (FPU)
- Primary cache memory (32K bytes for each of instruction and data, 2-way set associative)
- Secondary cache memory interface
 - 128-bit secondary cache interface
 - SSRAM interface (VR10000: 250 MHz MAX., VR12000: 200 MHz MAX.)
- Supports up to 16M bytes
- Operating frequency
 - <VR10000>
 - Internal: 250 MHz MAX.
 - External: 250 MHz MAX.
 - External/internal multiplication factor selectable from 1 to 4
 - <VR12000>
 - Internal: 300 MHz MAX.
 - External: 150 MHz MAX.
 - External/internal multiplication factor selectable from 2 to 10
- Multi-processor function
 - Up to four buses of cluster connection can be connected.
- Supply voltage
 - <VR10000>
 - $V_{DD} = 3.3 \text{ V} \pm 0.165 \text{ V}$ (μ PD30700)
 - $V_{DD} = 2.6 \text{ V} \pm 0.1 \text{ V}$ (μ PD30700L)
 - <VR12000>
 - $V_{DD} = 2.6 \text{ V} \pm 0.1 \text{ V}$ (μ PD30710)

Unless otherwise specified, the VR10000 is treated as the representative model throughout this document.

The information in this document is subject to change without notice.

APPLICATIONS

- UNIX™ servers
- Windows NT™ servers
- Desktop workstations, etc.

ORDERING INFORMATION

Part Number	Package	Maximum Internal Operating Frequency
μPD30700RS-180	599-pin ceramic LGA	180
μPD30700RS-200	599-pin ceramic LGA	200
μPD30700LRS-225 ^{Note}	599-pin ceramic LGA	225
μPD30700LRS-250 ^{Note}	599-pin ceramic LGA	250
μPD30710RS-300 ^{Note}	599-pin ceramic LGA	300

Note Under development

Remark LGA: Land Grid Array

PIN CONFIGURATION

- **599-pin ceramic LGA**
 μPD30700RS-180
 μPD30700RS-200
 μPD30700LRS-225
 μPD30700LRS-250
 μPD30710RS-300

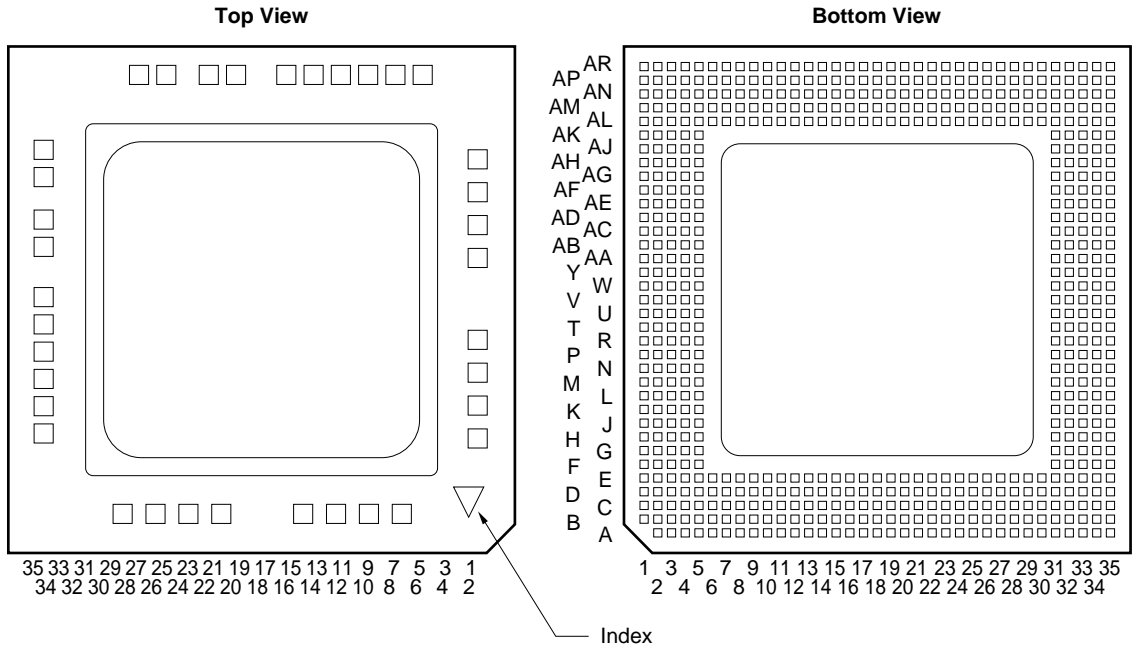

(1/4)

No.	Name	No.	Name	No.	Name	No.	Name
A1	–	B9	SCADCS	C17	SysAD41	D25	V _{SS}
A2	V _{DD}	B10	SCAAddr5	C18	V _{DD}	D26	V _{DD}
A3	V _{SS}	B11	V _{SS}	C19	SysAD36	D27	SCData68
A4	V _{DD} QSC	B12	SCData78	C20	SysAD32	D28	SCData64
A5	SCData89	B13	SCClk0	C21	V _{SS}	D29	V _{SS}
A6	SCData85	B14	V _{DD}	C22	V _{SS}	D30	SCAAddr12
A7	V _{SS}	B15	SCData72	C23	̄SysClkRet	D31	SCAAddr16
A8	SCADWr	B16	SysAD44	C24	V _{SS}	D32	V _{SS}
A9	SCAAddr8	B17	V _{SS}	C25	V _{DD} Pa	D33	SCDataChk0
A10	V _{DD} QSC	B18	SysAD40	C26	SCData71	D34	SCData29
A11	SCAAddr1	B19	V _{SS}	C27	V _{SS}	D35	V _{DD} QSC
A12	SCData76	B20	SysAD33	C28	SCData67	E1	SCClk5
A13	V _{SS}	B21	V _{SS}	C29	SCDataChk2	E2	V _{SS}
A14	SCData74	B22	DCOK	C30	V _{DD} QSC	E3	V _{DD}
A15	SysAD46	B23	SysClkRet	C31	SCAAddr13	E4	SCDataChk6
A16	V _{DD} QSys	B24	V _{SS} Pa	C32	SCAAddr18	E5	V _{DD}
A17	SysAD42	B25	V _{SS} Pa	C33	V _{DD} QSC	E6	SCData90
A18	SysAD37	B26	SCClk1	C34	V _{DD}	E7	SCData86
A19	SysAD35	B27	SCDataChk9	C35	V _{SS}	E8	V _{DD} QSC
A20	V _{DD} QSys	B28	V _{DD}	D1	V _{DD} QSC	E9	SCData80
A21	V _{SS}	B29	SCData65	D2	̄SCTCS	E10	SCADWay
A22	SysClk	B30	SCAAddr9	D3	SCDataChk8	E11	V _{SS}
A23	̄SysClk	B31	V _{SS}	D4	V _{SS}	E12	SCAAddr4
A24	V _{SS} Pa	B32	SCAAddr15	D5	SCData92	E13	SCAAddr0
A25	NC	B33	SCAAddr17	D6	SCData88	E14	V _{DD} QSC
A26	SCClk1	B34	V _{SS}	D7	V _{SS}	E15	SCClk0
A27	V _{SS}	B35	V _{DD}	D8	SCData82	E16	SysAD47
A28	SCData70	C1	V _{SS}	D9	̄SCADOE	E17	V _{SS}
A29	V _{SS}	C2	V _{DD}	D10	V _{DD}	E18	SysAD39
A30	SCDataChk4	C3	V _{DD} QSC	D11	SCAAddr6	E19	V _{SS}
A31	SCAAddr11	C4	SCData94	D12	SCAAddr2	E20	̄SysCyc
A32	V _{DD} QSC	C5	SCData91	D13	V _{SS}	E21	V _{SS}
A33	V _{SS}	C6	V _{DD} QSC	D14	SCData77	E22	V _{DD} Pd
A34	V _{DD}	C7	SCData84	D15	SCData73	E23	V _{SS}
A35	V _{SS}	C8	SCData81	D16	V _{DD}	E24	V _{SS}
B1	V _{DD}	C9	V _{SS}	D17	SysAD43	E25	V _{SS}
B2	V _{SS}	C10	SCAAddr7	D18	SysAD38	E26	SCData69
B3	SCData95	C11	SCAAddr3	D19	SysAD34	E27	SCData66
B4	SCData93	C12	V _{DD} QSC	D20	V _{DD}	E28	V _{DD} QSC
B5	V _{SS}	C13	SCData79	D21	V _{SS}	E29	SCAAddr10
B6	SCData87	C14	SCData75	D22	V _{SS} Pd	E30	SCAAddr14
B7	SCData83	C15	V _{SS}	D23	V _{SS}	E31	V _{DD}
B8	V _{DD}	C16	SysAD45	D24	V _{SS}	E32	SCData31

Note Connect this pin via a100-Ω resistor.

(2/4)

No.	Name	No.	Name	No.	Name	No.	Name
E33	V _{DD}	K1	V _{DD} QSC	P4	SCTag6	V32	SysAD6
E34	V _{SS}	K2	SCTag14	P5	V _{DD} QSC	V33	V _{DD}
E35	SCData27	K3	SCTag17	P31	V _{DD} QSC	V34	SysAD4
F1	V _{DD}	K4	V _{DD}	P32	SCData4	V35	SysAD2
F2	$\overline{\text{SCTWr}}$	K5	SCTag19	P33	SCData2	W1	SCClk4
F3	V _{DD} QSC	K31	SCData18	P34	V _{DD}	W2	V _{SS}
F4	$\overline{\text{SCClk5}}$	K32	V _{DD}	P35	SysAD15	W3	SCTagChk1
F5	V _{SS} ^{Note}	K33	SCData16	R1	SCTag0	W4	$\overline{\text{SCClk4}}$
F31	SCData30	K34	SCData11	R2	V _{DD} QSC	W5	V _{SS}
F32	SCData28	K35	V _{DD} QSC	R3	V _{SS}	W31	V _{SS}
F33	V _{DD} QSC	L1	SCTag12	R4	SCTag1	W32	SysAD1
F34	SCData25	L2	V _{SS}	R5	SCTag3	W33	JTCK
F35	SCData23	L3	V _{DD}	R31	SCData0	W34	V _{SS}
G1	V _{SS}	L4	SCTag15	R32	SysAD13	W35	JTDI
G2	SCTag22	L5	V _{SS}	R33	V _{SS}	Y1	V _{CC} QSys
G3	SCTag24	L31	V _{SS}	R34	SysAD14	Y2	SysCmd0
G4	V _{SS}	L32	SCData14	R35	SysAD12	Y3	SysCmd1
G5	$\overline{\text{SCTOE}}$	L33	SCData9	T1	V _{DD} QSC	Y4	V _{DD}
G31	SCData26	L34	V _{SS}	T2	NC	Y5	SysCmd3
G32	V _{SS}	L35	SCData7	T3	SCTWay	Y31	JTDO
G33	SCData21	M1	SCTag7	T4	V _{DD}	Y32	V _{DD}
G34	SCData19	M2	SCTag9	T5	SCTagLSBAddr	Y33	VrefSys
G35	V _{SS}	M3	V _{DD} QSC	T31	SysAD11	Y34	SysAD0
H1	SCTag20	M4	SCTag11	T32	V _{DD}	Y35	V _{DD} QSys
H2	V _{DD}	M5	SCTag13	T33	SysAD9	AA1	SysCmd2
H3	V _{DD} QSC	M31	SCData12	T34	SysAD10	AA2	SysCmd4
H4	SCTag25	M32	SCData10	T35	V _{DD} QSys	AA3	V _{SS}
H5	V _{DD} QSC	M33	V _{DD} QSC	U1	SCTagChk6	AA4	SysCmd5
H31	V _{DD} QSC	M34	SCData5	U2	V _{SS}	AA5	SysCmd7
H32	SCData24	M35	SCData3	U3	SCTagChk5	AA31	SCClk2
H33	V _{DD} QSC	N1	V _{SS}	U4	V _{SS} ^{Note}	AA32	SCData32
H34	V _{DD}	N2	SCTag5	U5	V _{SS}	AA33	V _{SS}
H35	SCData17	N3	SCTag8	U31	V _{SS}	AA34	JTMS
J1	SCTag16	N4	V _{SS}	U32	SysAD7	AA35	VrefSC
J2	SCTag18	N5	SCTag10	U33	SysAD5	AB1	SysCmd6
J3	V _{SS}	N31	SCData8	U34	V _{SS}	AB2	V _{DD}
J4	SCTag21	N32	V _{SS}	U35	SysAD8	AB3	SysCmd8
J5	SCTag23	N33	SCData6	V1	SCTagChk4	AB4	SysCmd10
J31	SCData22	N34	SCData1	V2	SCTagChk2	AB5	V _{DD} QSys
J32	SCData20	N35	V _{SS}	V3	V _{DD}	AB31	V _{DD} QSC
J33	V _{SS}	P1	SCTag2	V4	SCTagChk0	AB32	SCData35
J34	SCData15	P2	V _{DD}	V5	SCTagChk3	AB33	$\overline{\text{SCClk2}}$
J35	SCData13	P3	SCTag4	V31	SysAD3	AB34	V _{DD}

Note Connect this pin via a100- Ω resistor.

No.	Name	No.	Name	No.	Name	No.	Name
AB35	SCData33	AG3	V _{SS}	AL6	SCData124	AM14	SCData110
AC1	V _{SS}	AG4	̄SysGblPerf	AL7	SCData120	AM15	SCClk3
AC2	SysCmd9	AG5	̄SysWrRdy	AL8	V _{DD} QSC	AM16	V _{DD}
AC3	SysCmdPar	AG31	SCData53	AL9	SCData114	AM17	SysAD58
AC4	V _{SS}	AG32	SCData51	AL10	̄SCBDOE	AM18	SysAD54
AC5	̄SysReq	AG33	V _{SS}	AL11	SCBAddr8	AM19	SysAD52
AC31	SCData39	AG34	SCData48	AL12	SCBAddr4	AM20	V _{DD}
AC32	V _{SS}	AG35	SCData46	AL13	SCBAddr0	AM21	SysADChk4
AC33	SCData37	AH1	SysResp2	AL14	V _{DD} QSC	AM22	SysAD30
AC34	SCData34	AH2	V _{DD}	AL15	SCData106	AM23	V _{SS}
AC35	V _{SS}	AH3	V _{DD} QSys	AL16	SCData104	AM24	SysAD26
AD1	SysCmd11	AH4	SysStatePar	AL17	SysAD60	AM25	SysAD22
AD2	̄SysVal	AH5	V _{DD} QSys	AL18	SysAD56	AM26	V _{DD}
AD3	V _{DD} QSys	AH31	V _{DD} QSC	AL19	SysAD50	AM27	SCData102
AD4	̄SysGnt	AH32	SCData55	AL20	SysADChk6	AM28	SCData98
AD5	̄SysReset	AH33	V _{DD} QSC	AL21	SysADChk2	AM29	V _{SS}
AD31	SCData43	AH34	V _{DD}	AL22	V _{DD} QSys	AM30	SCBAddr11
AD32	SCData41	AH35	SCData50	AL23	SysAD28	AM31	SCBAddr15
AD33	V _{DD} QSC	AJ1	V _{SS}	AL24	SysAD24	AM32	V _{SS}
AD34	SCData38	AJ2	SysResp0	AL25	SysAD20	AM33	SCData63
AD35	SCData36	AJ3	̄SysRdRdy	AL26	SysAD16	AM34	SCData62
AE1	̄SysRel	AJ4	V _{SS}	AL27	SCData100	AM35	V _{DD} QSC
AE2	V _{SS}	AJ5	SysState1	AL28	V _{DD} QSC	AN1	V _{SS}
AE3	V _{DD}	AJ31	SCData57	AL29	SCBAddr9	AN2	V _{DD}
AE4	SysRespPar	AJ32	V _{SS}	AL30	SCBAddr13	AN3	V _{DD} QSC
AE5	V _{SS}	AJ33	SCData54	AL31	V _{DD}	AN4	SCDataChk7
AE31	V _{SS}	AJ34	SCData52	AL32	SCDataChk1	AN5	SCData125
AE32	SCData45	AJ35	V _{SS}	AL33	V _{DD}	AN6	V _{DD} QSC
AE33	SCData42	AK1	SysStateVal	AL34	V _{SS}	AN7	SCData118
AE34	V _{SS}	AK2	SysState2	AL35	SCData60	AN8	SCData115
AE35	SCData40	AK3	V _{DD} QSys	AM1	V _{DD} QSys	AN9	V _{SS}
AF1	V _{DD} QSys	AK4	̄SysCorErr	AM2	̄SysUncErr	AN10	SCBDCS
AF2	DCOk	AK5	̄SysNMI	AM3	V _{SS} ^{Note}	AN11	SCBAddr5
AF3	SysResp3	AK31	SCData61	AM4	V _{SS}	AN12	V _{DD} QSC
AF4	V _{DD}	AK32	SCData59	AM5	SCData126	AN13	SCData109
AF5	SysResp1	AK33	V _{DD} QSC	AM6	SCData122	AN14	SCData108
AF31	SCData49	AK34	SCData58	AM7	V _{SS}	AN15	V _{SS}
AF32	V _{DD}	AK35	SCData56	AM8	SCData116	AN16	SysAD62
AF33	SCData47	AL1	SysState0	AM9	SCData112	AN17	SysAD59
AF34	SCData44	AL2	V _{SS}	AM10	V _{DD}	AN18	V _{DD}
AF35	V _{DD} QSC	AL3	V _{DD}	AM11	SCBAddr6	AN19	SysAD51
AG1	̄SysRespVal	AL4	V _{SS} ^{Note}	AM12	SCBAddr2	AN20	SysAD48
AG2	SysResp4	AL5	V _{DD}	AM13	V _{SS}	AN21	V _{SS}

Note Connect this pin via a100-Ω resistor.

(4/4)

No.	Name	No.	Name	No.	Name	No.	Name
AN22	SysADChk0	AP8	V _{DD}	AP29	SCData97	AR15	SysAD63
AN23	SysAD29	AP9	SCBDW \bar{r}	AP30	SCBAddr10	AR16	V _{DD} QSys
AN24	V _{DD} QSys	AP10	SCBAddr7	AP31	V _{SS}	AR17	SysAD57
AN25	SysAD21	AP11	V _{SS}	AP32	SCBAddr16	AR18	SysAD55
AN26	SysAD18	AP12	SCBAddr1	AP33	SCBAddr17	AR19	SysAD49
AN27	V _{SS}	AP13	SCData107	AP34	V _{SS}	AR20	V _{DD} QSys
AN28	SCData99	AP14	V _{DD}	AP35	V _{DD}	AR21	SysADChk5
AN29	SCData96	AP15	SCData105	AR1	V _{SS}	AR22	SysADChk1
AN30	V _{DD} QSC	AP16	SysAD61	AR2	V _{DD}	AR23	V _{SS}
AN31	SCBAddr14	AP17	V _{SS}	AR3	V _{SS}	AR24	SysAD27
AN32	SCBAddr18	AP18	SysAD53	AR4	V _{SS} QSC	AR25	SysAD23
AN33	V _{DD} QSC	AP19	V _{SS}	AR5	SCData123	AR26	V _{DD} QSys
AN34	V _{DD}	AP20	SysADChk7	AR6	SCData119	AR27	SysAD17
AN35	V _{SS}	AP21	SysADChk3	AR7	V _{SS}	AR28	SCData101
AP1	V _{DD}	AP22	V _{DD}	AR8	SCData113	AR29	V _{SS}
AP2	V _{SS}	AP23	SysAD31	AR9	SCBDWay	AR30	SCDataChk3
AP3	SCDataChk5	AP24	SysAD25	AR10	V _{DD} QSC	AR31	SCBAddr12
AP4	SCData127	AP25	V _{SS}	AR11	SCBAddr3	AR32	V _{DD} QSC
AP5	V _{SS}	AP26	SysAD19	AR12	SCData111	AR33	V _{SS}
AP6	SCData121	AP27	SCData103	AR13	V _{SS}	AR34	V _{DD}
AP7	SCData117	AP28	V _{DD}	AR14	SCCIk3	AR35	V _{SS}

PIN NAMES

DCOK	: DC Voltage OK
JTCK	: JTAG Clock
JTDI	: JTAG Serial Data Input
JTDO	: JTAG Serial Data Output
JTMS	: JTAG Mode Select
SCAAddr (18 : 0), SCBAddr (18 : 0)	: Secondary Cache Address Bus
$\overline{\text{SCADCS}}$, $\overline{\text{SCBDCS}}$: Secondary Cache Data Chip Select
$\overline{\text{SCADOE}}$, $\overline{\text{SCBDOE}}$: Secondary Cache Data Output Enable
SCADWay, SCBDWay	: Secondary Cache Data Way
$\overline{\text{SCADWr}}$, $\overline{\text{SCBDWr}}$: Secondary Cache Data Write Enable
SCClk (5 : 0), $\overline{\text{SCClk}}$ (5 : 0)	: Secondary Cache Clock
SCData (127 : 0)	: Secondary Cache Data Bus
SCDataChk (9 : 0)	: Secondary Cache Data Check Bus
SCTag (25 : 0)	: Secondary Cache Tag Bus
SCTagChk (6 : 0)	: Secondary Cache Tag Check Bus
SCTagLSBAddr	: Secondary Cache Tag LSB Address
$\overline{\text{SCTCS}}$: Secondary Cache Chip Select
$\overline{\text{SCTOE}}$: Secondary Cache Tag Output Enable
SCTWay	: Secondary Cache Tag Way
$\overline{\text{SCTWr}}$: Secondary Cache Tag Write Enable
SysAD (63 : 0)	: System Address/Data Bus
SysADChk (7 : 0)	: System Address/Data Check Bus
SysClk, $\overline{\text{SysClk}}$: System Clock
SysClkRet, $\overline{\text{SysClkRet}}$: System Clock Return
SysCmd (11 : 0)	: System Command Bus
SysCmdPar	: System Command Bus Parity
$\overline{\text{SysCorErr}}$: System Correctable Error
$\overline{\text{SysCyc}}$: System Cycle
$\overline{\text{SysGbPerf}}$: System Globally Performed
$\overline{\text{SysGnt}}$: System Grant
$\overline{\text{SysNMI}}$: System Non-maskable Interrupt
$\overline{\text{SysRdRdy}}$: System Read Ready
$\overline{\text{SysReset}}$: System Reset
SysResp (4 : 0)	: System Response Bus
$\overline{\text{SysRespPar}}$: System Response Bus Parity
$\overline{\text{SysRespVal}}$: System Response Bus Valid
$\overline{\text{SysUncErr}}$: System Uncorrectable Error
$\overline{\text{SysVal}}$: System Valid
$\overline{\text{SysWrRdy}}$: System Write Ready
$\overline{\text{SysRel}}$: System Release
$\overline{\text{SysReq}}$: System Request

SysState (2 : 0)	: System State Bus
SysStatePar	: System State Bus Parity
<u>SysStateVal</u>	: System State Bus Valid
V _{DD}	: Power Supply
V _{DDPa}	: V _{DD} for the PLL Analog
V _{DDPd}	: V _{DD} for the PLL Digital
V _{DDQSC}	: V _{DD} for the Secondary Cache
V _{DDQSys}	: V _{DD} for the System Interface
VrefSC	: Voltage Reference for the Secondary Cache
VrefSys	: Voltage Reference for the System Interface
V _{SS}	: Ground
V _{SSPa}	: V _{SS} for the PLL Analog
V _{SSPd}	: V _{SS} for the PLL Digital
NC	: No Connection

TABLE OF CONTENTS

1. PIN FUNCTIONS	13
1.1 Pin Function List	13
1.2 Recommended Connection of Unused Pins	16
2. CPU INTERNAL ARCHITECTURE	17
2.1 Pipeline	17
2.1.1 Configuration	17
2.1.2 Operation	18
2.2 CPU Registers (virtual registers)	19
2.3 System Control Coprocessor (CP0)	20
2.3.1 CP0 registers	20
2.4 Data Format and Addressing	22
2.5 Virtual Storage	24
2.5.1 Virtual address space	24
2.5.2 Address translation	27
2.6 Cache	29
2.6.1 Primary cache	29
2.6.2 Secondary cache	29
3. FPU INTERNAL ARCHITECTURE	30
3.1 Internal Function Block	30
3.2 FPU Registers	30
3.3 Data Format	31
4. INTERFACE	32
4.1 System Interface	32
4.1.1 Setting operating frequency of system interface	32
4.2 Secondary Cache Interface	33
4.3 Clock Interface	33
4.3.1 System interface clock and processor clock	33
4.3.2 Secondary cache clock	33
4.4 System Configuration Example	33
4.4.1 Uni-processor system	33
4.4.2 Multi-processor system	35
4.5 BTMC Interface	36
4.6 DSD (Delay Speculative Dirty) Mode (V_R12000 only)	38
4.6.1 DSD mode delay	38
4.6.2 Secondary cache status in DSD mode	38
4.6.3 Other features	38
5. INTERNAL/EXTERNAL CONTROL FUNCTIONS	39
5.1 Reset Function	39
5.1.1 Power-ON reset and cold reset	39
5.1.2 Software reset	39
5.2 Interrupt Functions	39
5.3 JTAG Function	40

6. INSTRUCTION SET	41
6.1 Instruction Formats	41
6.2 CPU Instruction Set List	41
6.3 FPU Instruction Set List	46
6.4 Delay of Instruction	49
7. ELECTRICAL SPECIFICATIONS	50
8. PUSH-PULL OUTPUT BUFFER CIRCUIT	64
9. PACKAGE DRAWING	65

1. PIN FUNCTIONS

1.1 Pin Function List

(1/3)

Pin Name	I/O	Function
SCClk (5 : 0)	Output	Secondary cache clock signals.
$\overline{\text{SCClk}}$ (5 : 0)	Output	Secondary cache clock signals. Inverted SCClk (5:0) signals.
SCAAddr (18 : 0), SCBAddr (18 : 0)	Output	Secondary cache address bus. 19-bit address bus for secondary cache.
SCTagLSBAddr	Output	Secondary cache tag LSB address. Specifies the LSB address of a secondary cache tag.
SCADWay, SCBDWay	Output	Secondary cache data way. Specifies a way of secondary cache data.
SCData (127 : 0)	I/O	Secondary cache data bus. 128-bit bus to read or write data from or to the secondary cache.
SCDataChk (9 : 0)	I/O	Secondary cache data check bus. 10-bit bus used to read or write ECC and even parity for secondary cache data.
$\overline{\text{SCADOE}}$, $\overline{\text{SCBDOE}}$	Output	Secondary cache data output enable. Signals enabling output of secondary cache data.
$\overline{\text{SCADWr}}$, $\overline{\text{SCBDWr}}$	Output	Secondary cache data write enable. Signals enabling writing of secondary cache data.
$\overline{\text{SCADCS}}$, $\overline{\text{SCBDCS}}$	Output	Secondary cache data chip select. Signals enabling access of secondary cache data.
SCTWay	Output	Secondary cache tag way. Specifies the way of a secondary cache tag.
SCTag (25 : 0)	I/O	Secondary cache tag bus. 26-bit bus to read or write a tag to or from the secondary cache.
SCTagChk (6 : 0)	I/O	Secondary cache tag check bus. 7-bit bus used to read or write ECC for secondary cache tag.
$\overline{\text{SCTOE}}$	Output	Secondary cache tag output enable. Signal enabling output of a secondary cache tag.
$\overline{\text{SCTWr}}$	Output	Secondary cache tag write enable. Signal enabling writing of a secondary cache tag.
$\overline{\text{SCTCS}}$	Output	Secondary cache tag chip select. Signal enabling access to a secondary cache tag.
SysClk	Input	System clock. System clock input.
$\overline{\text{SysClk}}$	Input	System clock. System clock input. Inverted SysClk signal.
SysClkRet	Output	System clock. System clock output used for termination of system clock.
$\overline{\text{SysClkRet}}$	Output	System clock. System clock output used for termination of system clock. Inverted SysClkReset signal.
$\overline{\text{SysReq}}$	Output	System request. Signal requesting enabling issuance of a processor request when the V _R 10000 serves as a slave.

(2/3)

Pin Name	I/O	Function
$\overline{\text{SysGnt}}$	Input	System enable. Signal used by an external agent to request the V _R 10000 for use of the system interface.
$\overline{\text{SysRel}}$	I/O	System release. The master side of the system interface asserts this signal active for the duration of 1 SysClk cycle when it releases the right to use the system interface in the subsequent SysClk cycle.
$\overline{\text{SysRdRdy}}$	Input	System read ready. Indicates that the external agent is ready to accept a processor read request and upgrade request.
$\overline{\text{SysWrRdy}}$	Input	System write ready. Indicates that the external agent is ready to accept a processor write request and processor eliminate request.
SysAD (63 : 0)	I/O	System address/data bus. 64-bit address/data bus for communication between the V _R 10000 and external agent.
SysADChk (7 : 0)	I/O	System address/data check bus. 8-bit ECC bus for SysAD bus.
SysCmd (11 : 0)	I/O	System command bus. 12-bit bus for command communication between the V _R 10000 and external agent.
SysCmdPar	I/O	System command bus parity. One odd parity bit for the system command bus.
$\overline{\text{SysVal}}$	I/O	System valid. Signal indicating that the master side of the system interface drives a valid address/command/data onto the SysAD bus and SysCmd bus.
SysState (2 : 0)	Output	System state bus. 3-bit bus indicating issuance or addition of a processor coherent status response.
SysStatePar	Output	System state bus parity. One odd parity bit for the system state bus.
$\overline{\text{SysStateVal}}$	Output	System state bus valid. The V _R 10000 asserts this signal active for the duration of 1 SysClk cycle when it issues a processor coherent response status to the SysState bus.
SysResp (4 : 0)	Input	System response bus. 5-bit bus used by the external agent to issue an external end response.
SysRespPar	Input	System response bus parity. One odd parity bit for the system response bus.
$\overline{\text{SysRespVal}}$	Input	System response bus valid. The external agent asserts this signal active for 1 SysClk cycle when it issues an external end response to the SysResp bus.
$\overline{\text{SysReset}}$	Input	System reset. Signal used by the external agent to reset the V _R 10000.
$\overline{\text{SysNMI}}$	Input	System non-maskable interrupt. Signal used by the external agent to issue NMI.
$\overline{\text{SysCorErr}}$	Output	System correctable error. The V _R 10000 asserts this signal active for 1 SysClk cycle when it finds and correct a correctable error.
$\overline{\text{SysUncErr}}$	Output	System uncorrectable error. The V _R 10000 asserts this signal active for 1 SysClk cycle when it finds an uncorrectable tag error.

(3/3)

Pin Name	I/O	Function
$\overline{\text{SysGblPerf}}$	Input	System global perfect. An external agent uses this signal to indicate completion of a processor request to all external agents.
$\overline{\text{SysCyc}}$	Input	System cycle. The external agent uses this signal to define a virtual system interface clock in hardware emulation environment.
JTDI	Input	JTAG data input. Inputs JTAG serial data.
JTDO	Output	JTAG data output. Outputs JTAG serial data.
JTCK	Input	JTAG clock input. Inputs JTAG serial clock. Keep this signal low when the JTAG interface is not used.
JTMS	Input	JTAG mode select. Selects a mode of JTAG.
DCOK	Input	DC voltage enable. The external agent asserts this signal active when the following signals are stable: V_{DD} , V_{DDQSC} , V_{DDQSys} , V_{refSC} , V_{refSys} , V_{DDPa} , V_{DDPd} , SysClk
V_{DD}	Input	Power supply pin. Power supply for the CPU core.
V_{DDQSC}	Input	Secondary cache V_{DD} . Power supply for the output driver of the secondary cache interface.
V_{DDQSys}	Input	System interface V_{DD} . Power supply for the output driver of the system interface.
V_{refSC}	Input	Secondary cache voltage. Reference voltage for the input pins of the secondary cache interface.
V_{refSys}	Input	System interface voltage. Reference voltage for the input pins of the system interface.
V_{DDPa}	Input	PLL analog V_{DD} . Power supply for the PLL analog circuit.
V_{DDPd}	Input	PLL digital V_{DD} . Power supply for the PLL digital circuit.
V_{SS}	Input	Ground potential pin. Ground for the CPU core and output driver.
V_{SSPa}	Input	PLL analog GND. Ground for the PLL analog.
V_{SSPd}	Input	PLL digital GND. Ground for PLL digital.
NC	—	No connection. Leave this pin unconnected.

1.2 Recommended Connection of Unused Pins

Table 1-1 shows the recommended connection of unused pins.

Table 1-1. Recommended Connection of Unused Pins

Pin Name	I/O	Recommended Connection
JTDI	Input	Connect each of these pins to V _{DD} via a resistor.
JTCK		
JTMS		
̄SysNMI		Connect this pin to V _{DDQ} via resistor of 100 Ω or more.
̄SysRdRdy		Connect each of these pins to V _{SS} via a resistor of 100 Ω or more.
̄SysWrRdy		
̄SysGblPerf		
̄SysCyc		
SysADChk (7 : 0)	I/O	Connect each of these pins to V _{SS} or V _{DDQ} via a resistor or 100 Ω or more.

2. CPU INTERNAL ARCHITECTURE

2.1 Pipeline

2.1.1 Configuration

The V_R10000 has a 5-way super scalar pipeline as illustrated below. This pipeline can simultaneously fetch and decode four instructions in 1 Pcycle.

- (1) FP addition pipeline
- (2) FP multiplication pipeline
- (3) Integer ALU1 pipeline
- (4) Integer ALU2 pipeline
- (5) Load/store pipeline

Figure 2-1. Pipeline

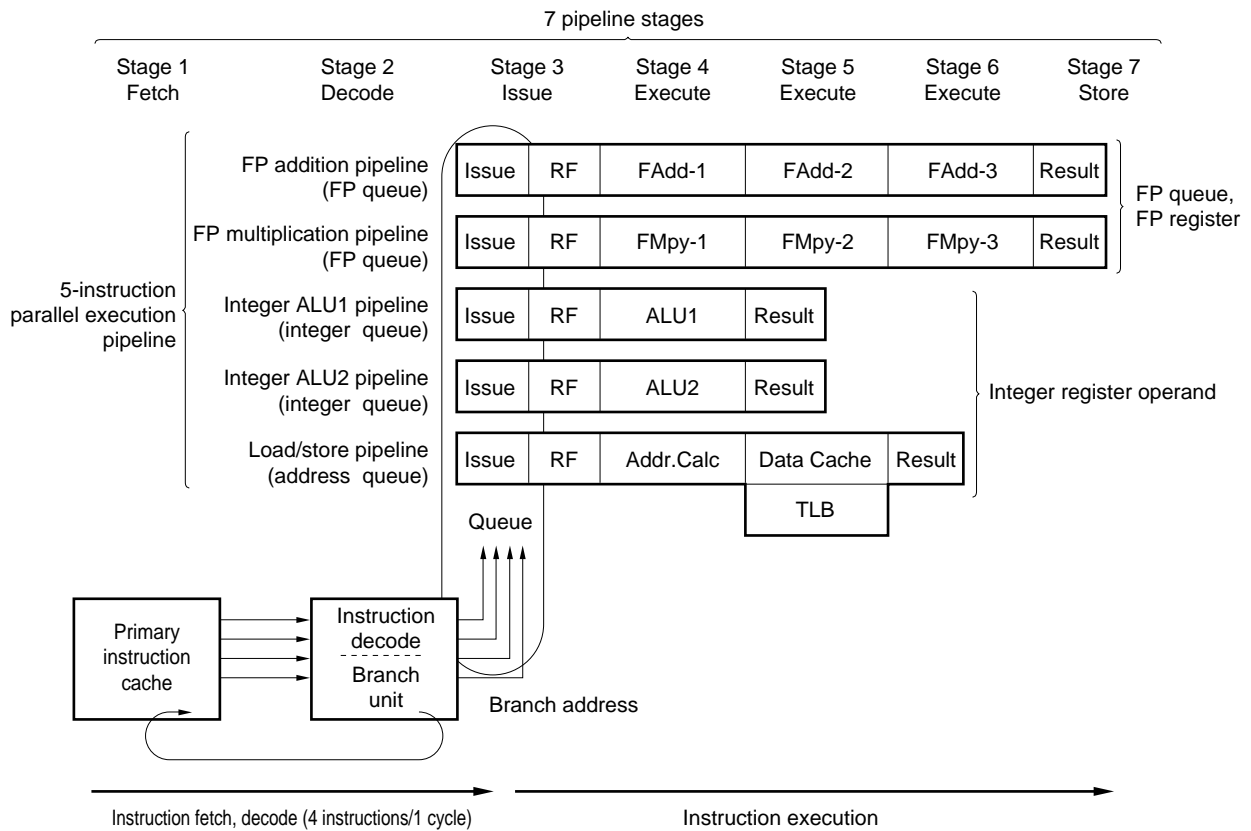

2.1.2 Operation

The pipeline of the Vr10000 has seven stages. The operation of each stage is described below:

(1) Stage 1 (fetch)

Four instructions are fetched in 1 cycle and stored to the instruction register.

(2) Stage 2 (decode)

The four instructions fetched in stage 1 are decoded.

(3) Stage 3 (issue)

The decoded instructions are written to a queue. The Vr10000 has an FP queue, integer queue, and address queue. In addition, an operand is read from the register file.

(4) Stage 4 through stage 6 (execute)

The instructions are executed. The execution pipeline and execution cycle differ depending on the type of instruction.

(a) FP addition pipeline

Executes floating-point addition instructions in 3 PCycle.

(b) FP multiplication pipeline

Executes floating-point multiplication, division, and square root instructions in 3 PCycle.

(c) Integer ALU1 pipeline

Executes integer addition, subtraction, shift, and logic instructions in 1 PCycle.

(d) Integer ALU2 pipeline

Executes integer addition, subtraction, and logic instructions in 1 PCycle.

(e) Load/store pipeline

Generates a memory address used for integer or floating-point load/store instructions.

(5) Stage 7 (store)

The results of executing the instructions are stored to registers.

2.2 CPU Registers (virtual registers)

Figure 2-2 shows the CPU registers of the V_R10000. Physically, sixty-four general-purpose registers are available. Of these, however, only thirty-two can be accessed by software or an external agent. Mapping of the other registers is automatically controlled by the CPU. The bit width of a register is determined by the operation mode of the V_R10000 (32 bits in 32-bit mode, or 64 bits in 64-bit mode).

Of the thirty-two general-purpose registers, the following two have special meanings.

- Register r0 : The contents of this register are always 0. Register r0 can be used as the target register of an instruction when the result of an operation is to be discarded. This register can also be used as a source register when the value of 0 is necessary.
- Register r31: This is a link system for the JAL and JALR instructions. Therefore, do not use this register with any other instructions.

Two multiplication/division registers (HI and LO) are used to store the result of integer multiplication, or quotient (LO) and remainder (HI) resulting from integer division.

The load link register is used to synchronize two or more V_R10000s in a multi-processor system.

Figure 2-2. CPU Registers

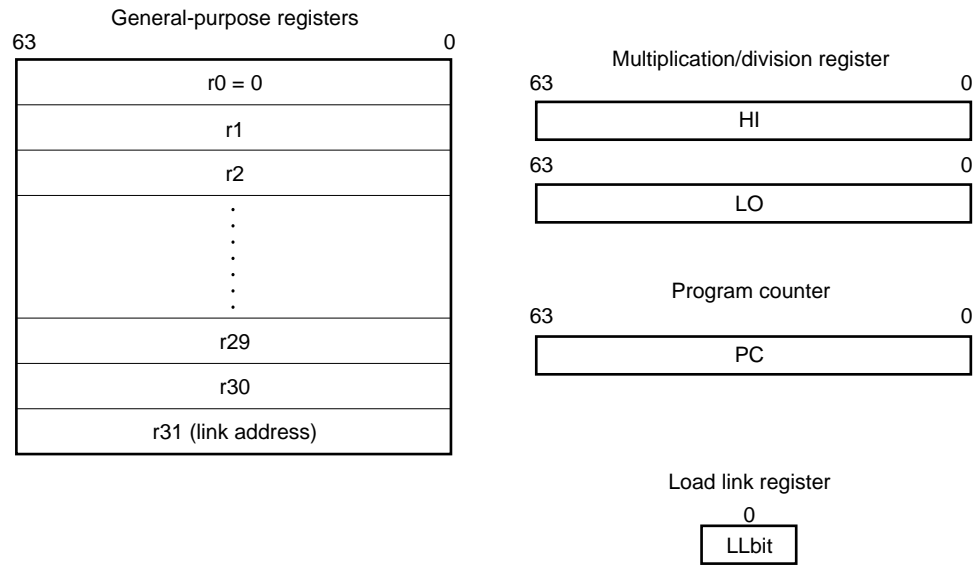

There is no program status word (PSW). The function of PSW is substituted by the status register and cause register incorporated into the system control coprocessor (CP0).

2.3 System Control Coprocessor (CP0)

The CP0 registers/CP0 instructions access the TLB and cache. Manipulating a mode in which the Vr10000 is used, exceptions, and interrupts are also controlled by the CP0. In addition, the CP0 also has a test/debug function.

2.3.1 CP0 registers

All the CP0 registers that can be used with the Vr10000 are listed below. Writing or reading an unused register (RFU) is undefined.

Figure 2-3. CPU0 Registers and TLB

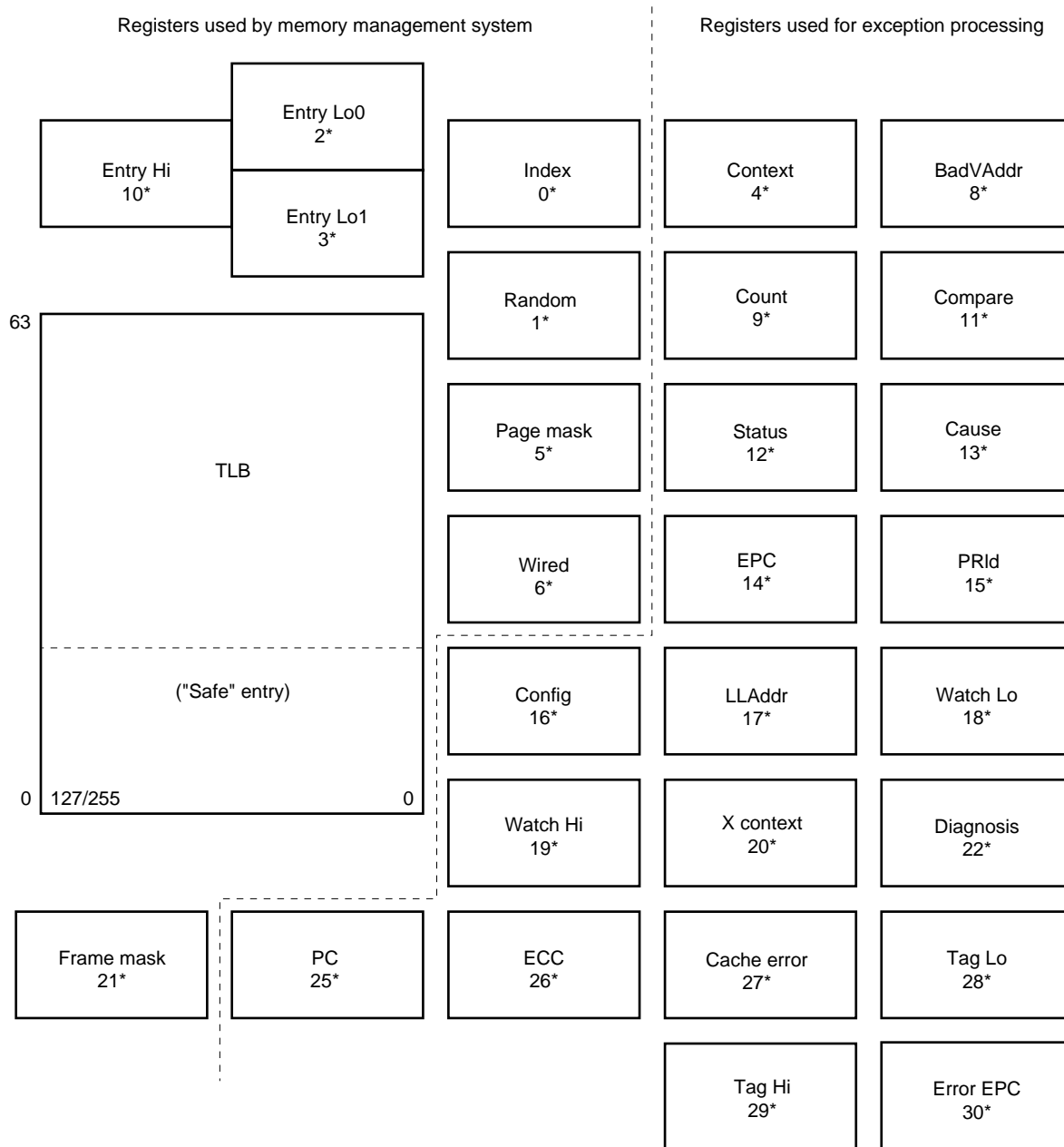

Remark "*" indicates a register number.

Table 2-1. CP0 Register List

No.	Register	Description
0	Index	TLB entry programmable pointer
1	Random	TLB entry random pointer
2	Entry Lo0	Second half of TLB entry for even number VPN
3	Entry Lo1	Second half of TLB entry for odd number VPN
4	Context	Pointer to virtual PTE table of kernel in 32-bit mode
5	Page mask	TLB page mask
6	Wired	Number of wired TLB entries
7	—	RFU (Reserved for Future Use)
8	BadVAddr	Virtual address at which last error has occurred
9	Count	Timer count
10	Entry Hi	First half of TLB entry (including VPN and ASID)
11	Compare	Timer comparison
12	Status	Status register
13	Cause	Cause of last exception
14	EPC	Exception program counter
15	PRId	Processor revision identifier
16	Config	Configuration register
17	LLAddr	Address of LL instruction
18	Watch Lo	Low-order bits of memory reference trap address
19	Watch Hi	High-order bits of memory reference trap address
20	X context	Pointer to virtual PTE table of kernel in 64-bit mode
21	Frame mask	Bit mask of entry Lo register
22	Diagnosis	Branch diagnosis
23, 24	—	RFU
25	PC	Performance counter
26	ECC	ECC of secondary cache and parity of primary cache
27	Cache error	Index of cache error and status field
28	Tag Lo	Cache tag register, low-order
29	Tag Hi	Cache tag register, high-order
30	Error EPC	Error exception program counter
31	—	RFU

2.4 Data Format and Addressing

The Vr10000 has the following four types of data formats:

- Double word (64 bits)
- Word (32 bit)
- Half word (16 bits)
- Byte (8 bits)

If the data format is double word, word, or half word, the byte order can be set to bit endian or little endian by using the BE bit of the config register.

Figure 2-4. Byte Address in Word: Big Endian

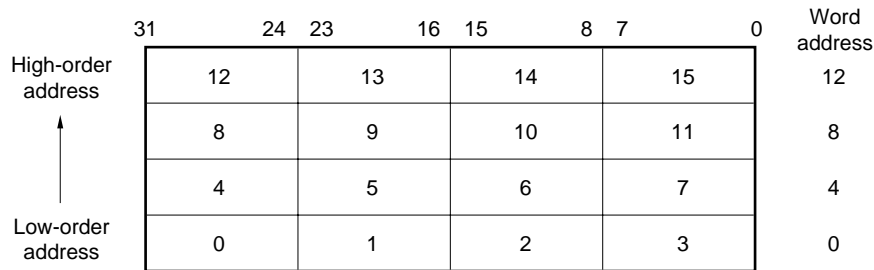

- Remarks**
1. The most significant byte is the least significant address.
 2. A word is addressed by the address of the most significant byte.

Figure 2-5. Byte Address in Word: Little Endian

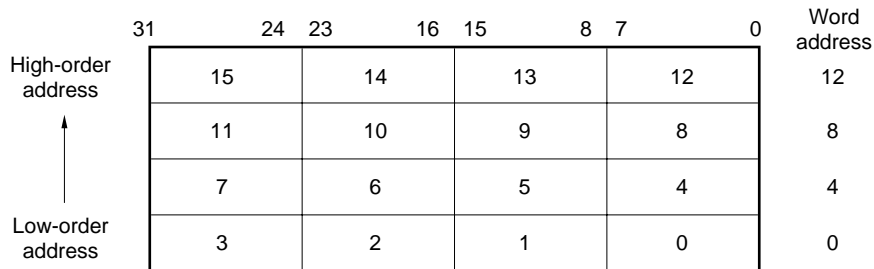

- Remarks**
1. The least significant byte is the least significant address.
 2. A word is addressed by the address of the least significant byte.

Figure 2-6. Byte Address in Double Word: Big Endian

	Word				Half word				Byte				
	63			32	31			16	15	8	7	0	Double word address
High-order address	16	17	18	19	20	21	22	23					16
	8	9	10	11	12	13	14	15					8
Low-order address	0	1	2	3	4	5	6	7					0

- Remarks**
1. The most significant byte is the least significant address.
 2. A word is addressed by the address of the most significant byte.

Figure 2-7. Byte Address in Double Word: Little Endian

	Word				Half word				Byte				
	63			32	31			16	15	8	7	0	Double word address
High-order address	23	22	21	20	19	18	17	16					16
	15	14	13	12	11	10	9	8					8
Low-order address	7	6	5	4	3	2	1	0					0

- Remarks**
1. The least significant byte is the least significant address.
 2. A word is addressed by the address of the least significant byte.

2.5 Virtual Storage

2.5.1 Virtual address space

The Vr10000 has two operation modes, the 32-bit and 64-bit modes. In addition, it has three operating modes: the user mode, supervisor mode, and kernel mode. Figures 2-8 through 2-11 show the virtual address spaces in the respective modes.

Figure 2-8. User Mode Address Space

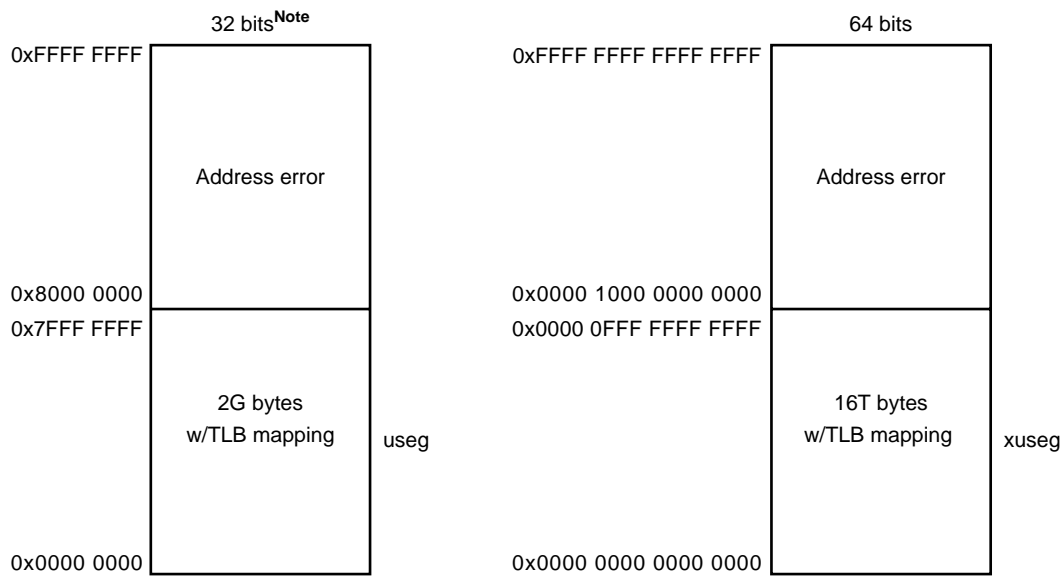

Note In the 32-bit mode, the value of bit 31 is sign-extended to bits 32 through 63.

Figure 2-9. Supervisor Mode Address Space

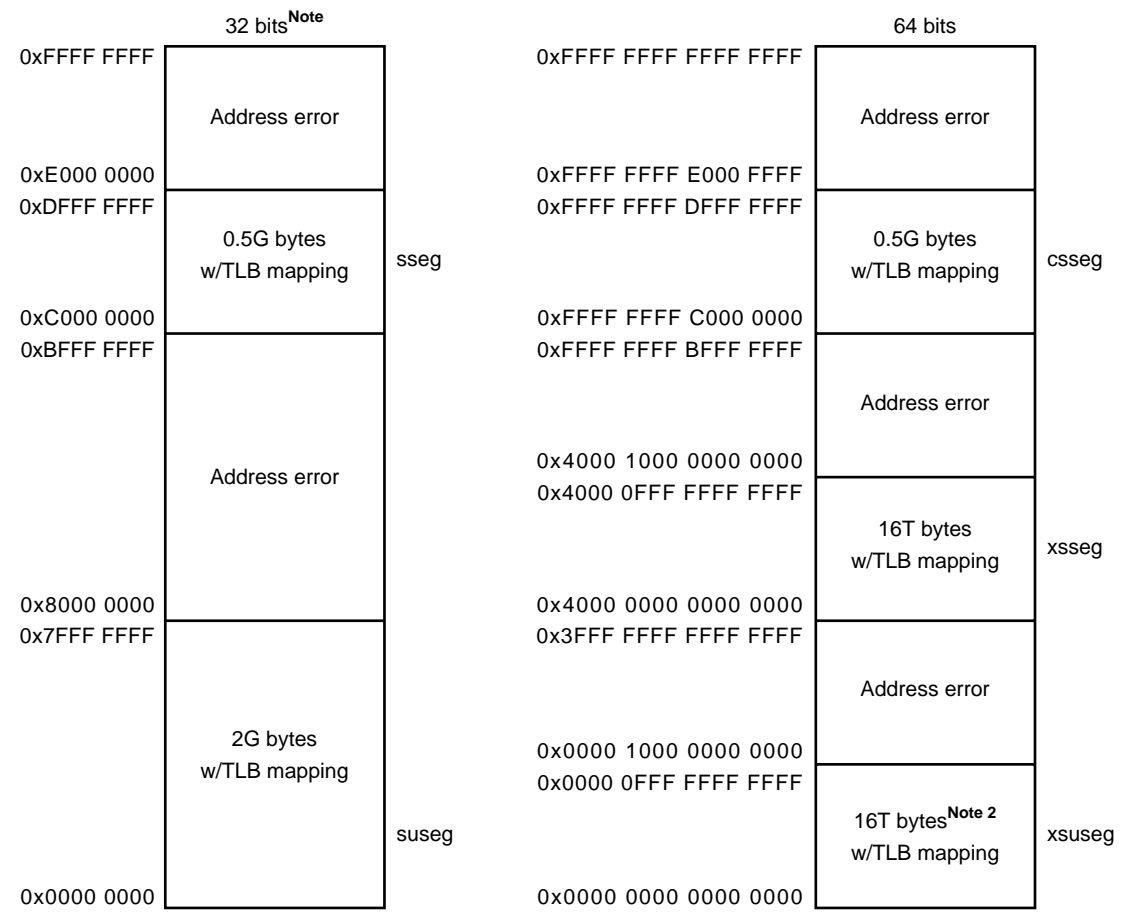

- Notes**
1. In the 32-bit mode, the value of bit 31 is sign-extended to bits 32 through 63.
 2. If the UX bit of the status register is 0, 0x0000 0000 8000 0000 through 0x0000 0FFF FFFF FFFF cause an address error.

Figure 2-10. Kernel Mode Address Space

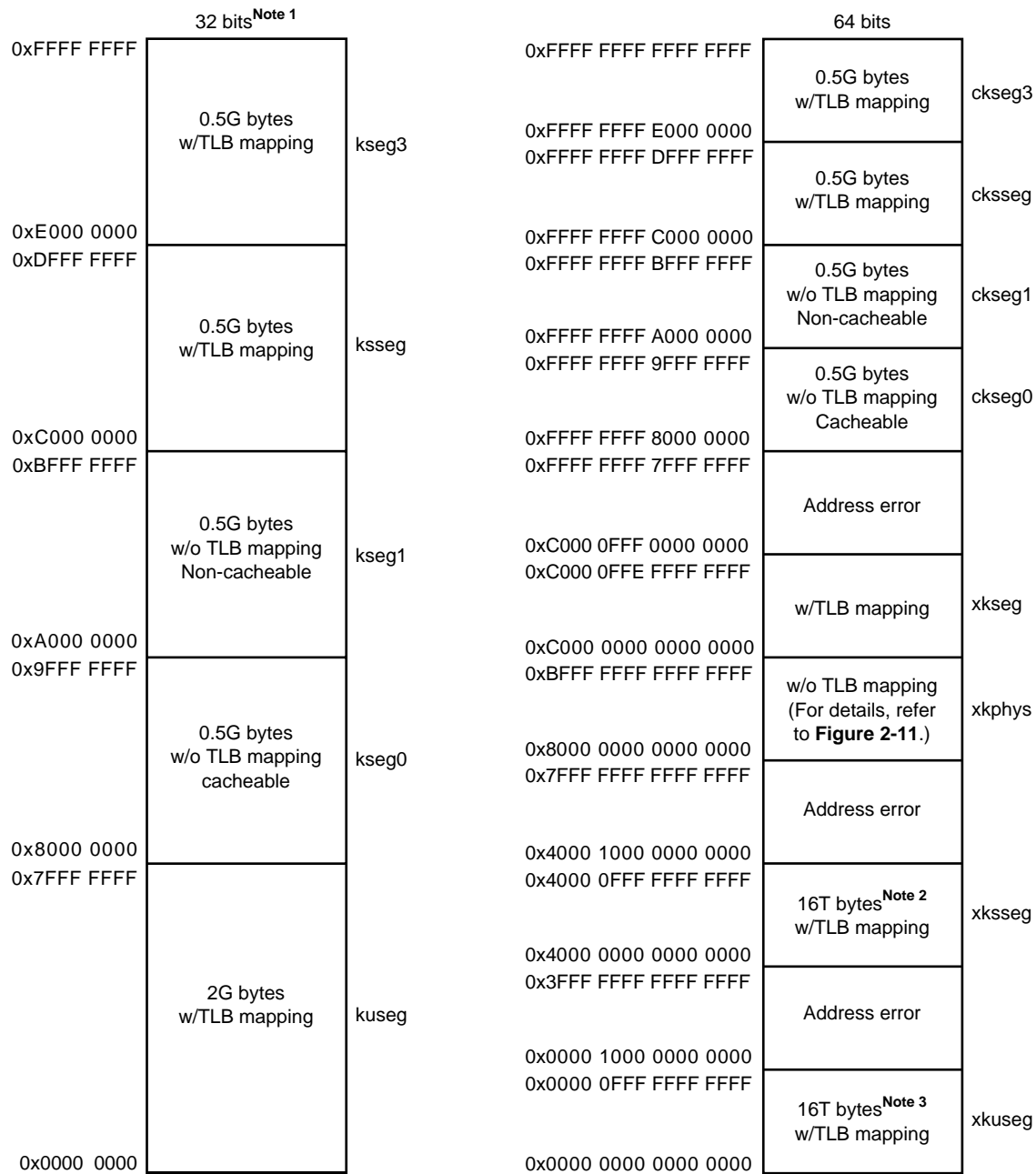

- Notes**
1. In the 32-bit mode, the value of bit 31 is sign-extended to bits 32 through 63.
 2. If the SX bit of the status register is 0, this area causes an address error.
 3. If the UX bit of the status register is 0, 0x0000 0000 8000 0000 through 0x0000 0FFF FFFF FFFF cause an address error.

Figure 2-11. Details of xkphys Area

0xBFFF FFFF FFFF FFFF	Address error
0xB800 0001 0000 0000 0xB800 0000 FFFF FFFF	4G bytes w/o TLB mapping Cacheable
0xB800 0000 0000 0000 0xB7FF FFFF FFFF FFFF	Address error
0xB000 0001 0000 0000 0xB000 0000 FFFF FFFF	4G bytes w/o TLB mapping Cacheable
0xB000 0000 0000 0000 0xAFFF FFFF FFFF FFFF	Address error
0xA800 0001 0000 0000 0xA800 0000 FFFF FFFF	4G bytes w/o TLB mapping Cacheable
0xA800 0000 0000 0000 0xA7FF FFFF FFFF FFFF	Address error
0xA000 0001 0000 0000 0xA000 0000 FFFF FFFF	4G bytes w/o TLB mapping Cacheable
0xA000 0000 0000 0000 0x9FFF FFFF FFFF FFFF	Address error
0x9800 0001 0000 0000 0x9800 0000 FFFF FFFF	4G bytes w/o TLB mapping Cacheable
0x9800 0000 0000 0000 0x97FF FFFF FFFF FFFF	Address error
0x9000 0001 0000 0000 0x9000 0000 FFFF FFFF	4 G bytes w/o TLB mapping Non-cacheable
0x9000 0000 0000 0000 0x8FFF FFFF FFFF FFFF	Address error
0x8800 0001 0000 0000 0x8800 0000 FFFF FFFF	4G bytes w/o TLB mapping Cacheable
0x8800 0000 0000 0000 0x87FF FFFF FFFF FFFF	Address error
0x8000 0001 0000 0000 0x8000 0000 FFFF FFFF	4G bytes w/o TLB mapping Cacheable
0x8000 0000 0000 0000	

2.5.2 Address translation

Virtual addresses are translated into physical addresses by the internal TLB (Translation Lookaside Buffer) in page units. The TLB is of full-associative configuration and has 64 entries at the virtual address side and 32 entries at the physical address side. The page size can be changed from 4K bytes to 16M bytes.

If a hit of a TLB entry does not occur, a TLB non-coincidence exception occurs in the 32-bit mode and an XTLB non-coincidence exception occurs in the 64-bit mode. If this happens, replace the contents of the TLB by software.

Figure 2-12 outlines address translation.

Figure 2-12. Outline of Address Translation

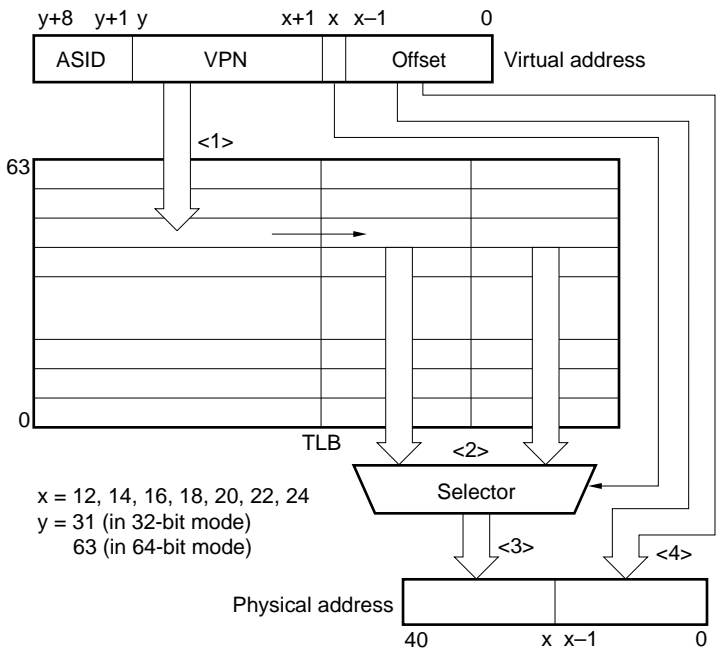

- <1> A virtual address page number (VPN) is compared with VPN in TLB.
- <2> If the two VPNs coincide, a page frame number (PFN) indicating the high-order bits of a physical address is output to the selector.
- <3> If the least significant bit of VPN is 0, an even page is selected; if it is 1, an odd page is selected. The selected page is output to the high-order bits of the physical address.
- <4> The offset is output to the low-order bits of the physical address without via TLB.

TLB entries are read or written by loading/storing the TLB entry indicated by the index register and the random register from or to the entry Hi, entry Lo1, Entry Lo0, and page mask registers.

Figure 2-13 outlines TLB manipulation.

Figure 2-13. Outline of TLB Manipulation

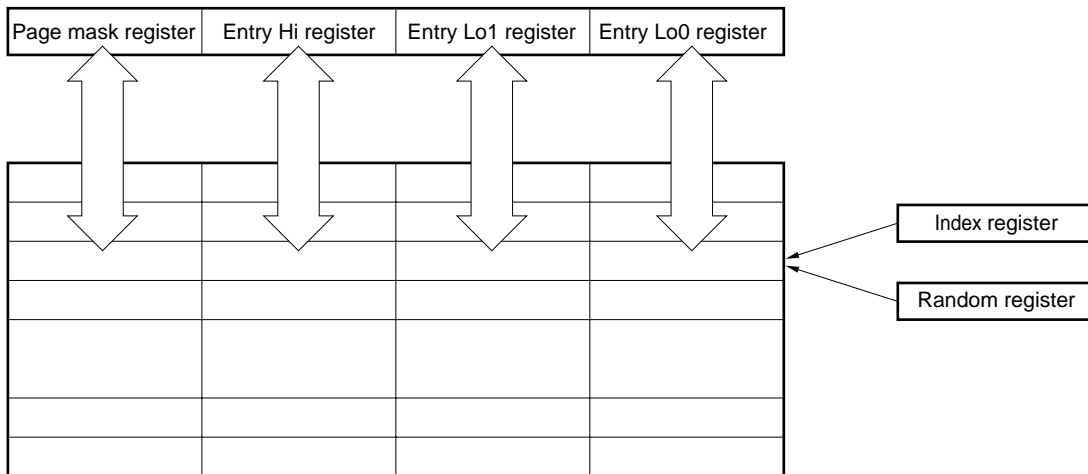

2.6 Cache

The Vr10000 has a primary instruction cache and primary data cache. In addition, it has a secondary cache interface to connect an external secondary cache.

2.6.1 Primary cache

(1) Primary instruction cache

Here are the features of the primary instruction cache:

- Internal cache memory
- Capacity: 32K bytes
- 16-word cache line
- 2-way set associative
- Physical index address
- Physical tag check

(2) Primary data cache

Here are the features of the primary data cache.

- Internal cache memory
- Capacity: 32K bytes
- 8-word cache line
- 2-bank configuration
- 2-way set associative
- Non-Blocking method
- Write back method
- Physical index address
- Physical tag check

2.6.2 Secondary cache

The Vr10000 can use an external secondary cache. The features of the secondary cache are as follows:

- Capacity: 512K to 16M bytes
- 16-/32-word cache line
- 2-way set associative
- Way prediction table
- Write back method
- Non-Blocking method
- Physical index address
- Physical tag check

3. FPU INTERNAL ARCHITECTURE

3.1 Internal Function Block

Figure 3-1 shows the internal block of the FPU.

The FPU can execute all the floating-point instructions defined by MIPS ISA.

Figure 3-1. Internal Block of FPU

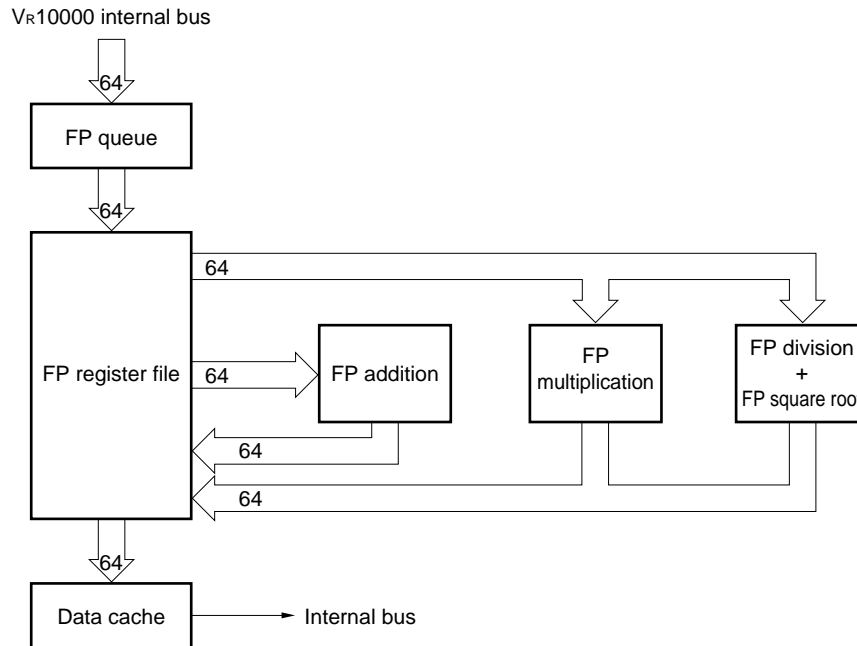

3.2 FPU Registers

(1) Floating-point general-purpose registers (FGR)

These are physical general-purpose registers that can be directly accessed. Thirty-two of these registers are available. The bit length of each register differs depending on the content of the FR bit of the status register.

(2) Floating-point registers (FPR)

These are logical 64-bit registers that hold a floating-point value when a floating-point operation is executed. The number of these registers varies depending on the content of the FR bit of the status register.

Figure 3-2. Registers of FPU

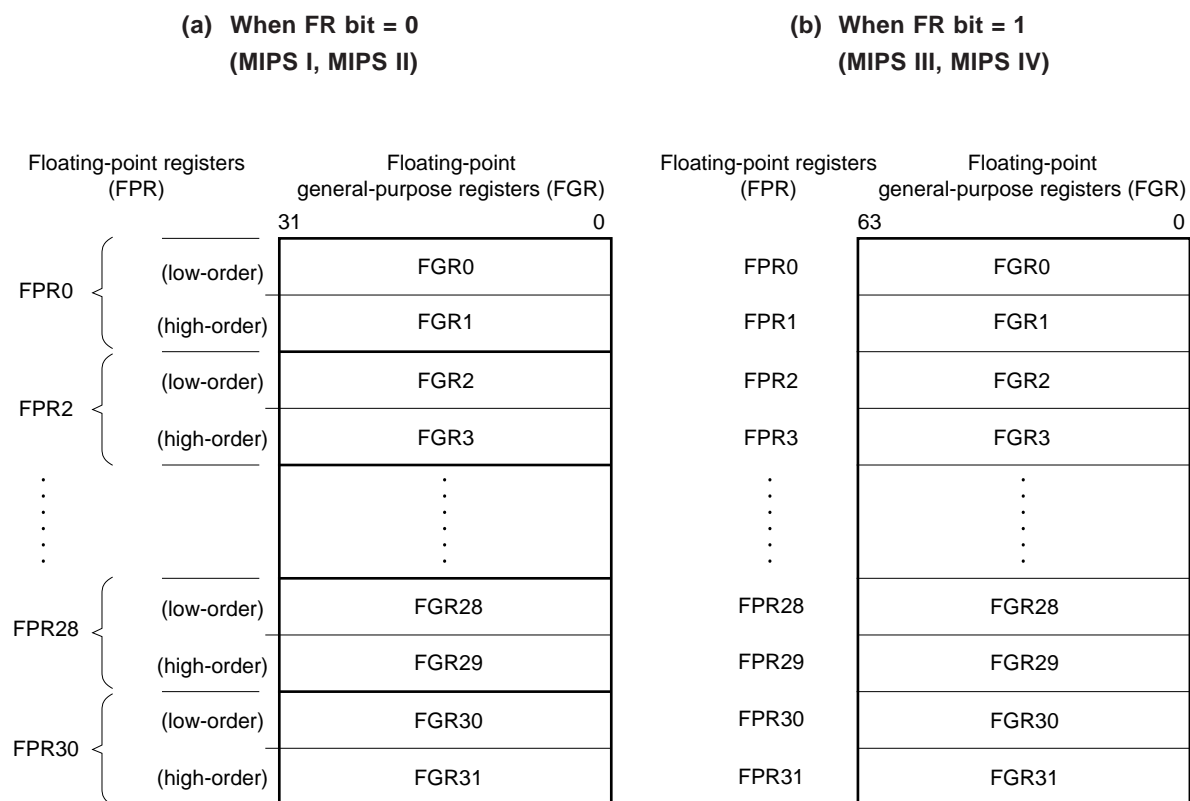

3.3 Data Format

(1) Floating-point format

The FPU supports IEEE754 floating-point operations of 32 bits (single precision) and 64 bits (double precision).

(2) Fixed-point format

A fixed-point value is calculated in the form of 2's complement.

4. INTERFACE

4.1 System Interface

The I/O timing of the Vr10000 is as follows:

- Output starts changing at the rising edge of SysClk.
- Input is latched at the rising edge of SysClk.

The following two buses are used for system interfacing.

- SysAD (63:0) : This bus transfers addresses and data.
- SysCmd (11:0): This bus transfers command data identifiers.

Both SysAD and SysCmd are bidirectional buses and are driven by the Vr10000 or external agent. Depending on the direction in which they are driven, these buses are in the following two statuses.

- Master status : Driven by the Vr10000 to issue a processor request.
- Slave status : Driven by the external agent to issue an external request.

The following two cycles are used depending on the information included in the SysAD bus.

- Address cycle : A valid address is included in the SysAD bus.
- Data cycle : Valid data is included in the SysAD bus.

Next, the interface control signals are briefly explained.

- $\overline{\text{SysReq}}$: Signal used by the Vr10000 to request the right to use the system interface.
- $\overline{\text{SysGnt}}$: Signal used by the external agent to grant the Vr10000 the right to use the system interface.
- $\overline{\text{SysRel}}$: Asserted active when the master of the system interface releases the right of use.
- $\overline{\text{SysRdRdy}}$: Indicates that the external agent is ready to accept a processor read request and upgrade request.
- $\overline{\text{SysWrRdy}}$: Indicates that the external agent is ready to accept a processor write request and processor eliminate request.
- $\overline{\text{SysVal}}$: Asserted active when the master of the system interface outputs valid data to the SysAD and SysCmd buses.
- SysState (2:0) : Signal used by the Vr10000 to issue a coherent status request.
- SysResp (4:0) : Signal used by the external agent to issue an external end response.
- SysGblPerf : Signal used by the external agent to indicate that all processor requests have been completed.

4.1.1 Setting operating frequency of system interface

The Vr10000 can select the operating frequency of the system interface.

The clock (PClk) for pipeline operation is generated based on the clock (SysClk) input from an external source. The factor by which SysClk is multiplied to generate PClk is set by using the BTMC interface at reset. For details, refer to SysAD (9:12) in **Table 4-1 Mode Setting in Boot Time Mode**.

4.2 Secondary Cache Interface

The V_R10000 has a secondary cache control circuit, so that an external secondary cache memory can be connected. The V_R10000 can also select the operating frequency of the secondary cache interface.

SCClk, at which the secondary cache is to operate, is generated based on the operating clock (PClk) of the V_R10000. The factor by which SysClk is multiplied to generate PClk is set by using the BTMC interface at reset. For details, refer to SysAD (9:12) in **Table 4-1 Mode Setting in Boot Time Mode**.

4.3 Clock Interface

4.3.1 System interface clock and processor clock

The V_R10000 generates a processor clock (PClk), which is the internal operating clock, from the clock (SysClk and $\overline{\text{SysClk}}$) input to the V_R10000, by using the PLL. It always samples the SysClk and $\overline{\text{SysClk}}$ signals during operation, in order to check to see if the following expression is satisfied.

$$\text{PClk} = \text{SysClk} \times (\text{SysClkDiv} + 1)/2$$

Example Where SysClk = 50 MHz and SysClkDiv = 7
 $\text{PClk} = 50 \times 8/2 = 200 \text{ MHz}$

4.3.2 Secondary cache clock

The V_R10000 supplies clocks for secondary cache (SCClk (5:0) and $\overline{\text{SCClk}} (5:0)$) to the external secondary cache. SCClk (5:0) are generated from SysClk.

The relation between SCClk (5:0) and SysClk can be expressed by the following expression.

$$\text{SCClk} = \text{SysClk} \times (\text{SysClkDiv} + 1)/(\text{SCClkDiv} + 1)$$

Example Where SysClk = 50 MHz, SysClkDiv = 7, and SCClkDiv = 2
 $\text{SCClk} = 50 \times 8/3 = 133 \text{ MHz}$

4.4 System Configuration Example

Because the V_R10000 employs a cluster bus, it can also support a multi-processor system. Examples of configuration of a uni-processor system and a multi-processor system are shown below.

4.4.1 Uni-processor system

This system uses only one V_R10000, as shown in Figure 4-1.

Figure 4-1. Example of Configuration of Uni-Processor System

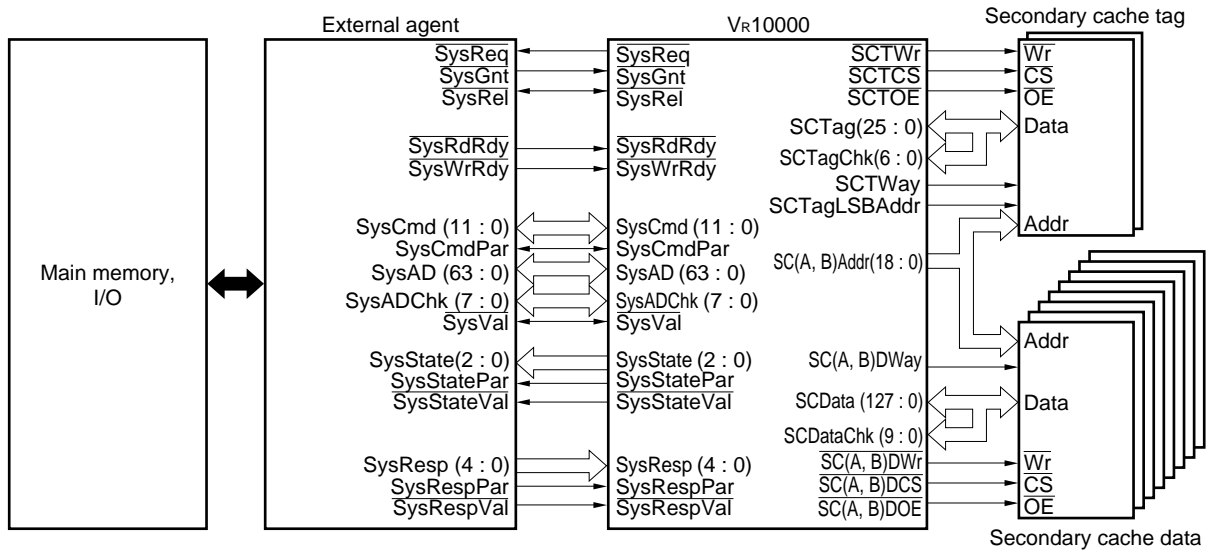

4.4.2 Multi-processor system

Up to four Vr10000s can be connected to the cluster bus. While a Vr10000 stands by for a response after it has issued a request, it can receive up to four processings. Figure 4-2 shows an example of multi-processor system configuration.

Figure 4-2. Example of Configuration of Multi-Processor System

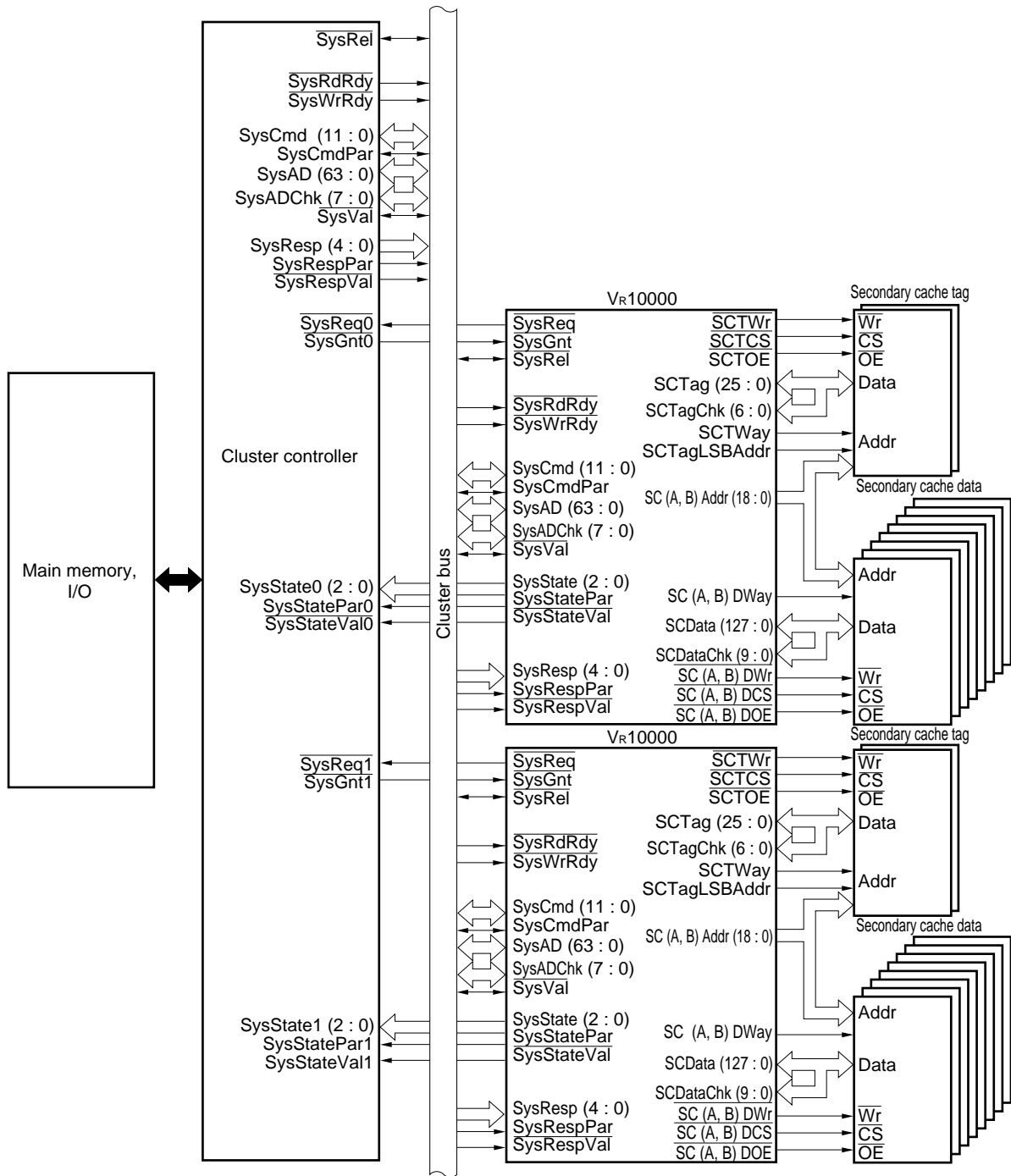

4.5 BTMC Interface

The operation of the Vr10000 is set by the mode bit. The content of the mode bit is stored to the processor via SysAD (63:0) at power-ON reset or by cold reset sequence while $\overline{\text{SysGnt}}$ is active. The content of the mode bit that is set via SysAD (24:0) is stored to bits 24 through 0 of the config register.

Table 4-1 shows the correspondence between the SysAD bus and mode setting in the boot time mode.

Table 4-1. Mode Setting in Boot Time Mode (1/2)

SysAD	Mode Setting	
	Vr10000	Vr12000
0 : 2	Kseg0CA: Kseg0 cache status 0, 1: RFU 2: Non-cacheable 3: Cacheable, non-coherent 4: Cacheable, coherent exclusive 5: Cacheable, coherent exclusive on write 6: RFU 7: Non-cacheable, accelerate	
3, 4	DevNum: Processor number	
5	CohPrcReqTar: Issuance destination of processor coherent request 0: External agent 1: All	
6	PrcElmReq: Enables processor eliminate request 0: Disabled 1: Enabled	
7, 8	PrcReqMax: Number of processor requests that can be kept pending on system bus 0: 1 1: 2 2: 3 3: 4	
9 : 12	SysClkDiv: Multiple of PClk in respect to SysClk 0: RFU 1: × 1 2: × 1.5 3: × 2 4: × 2.5 5: × 3 6: × 3.5 7: × 4 8 to F: RFU	SysClkDiv: Multiple of PClk in respect to SysClk 0: RFU 1: RFU 2: RFU 3: × 2 4: × 2.5 5: × 3 6: × 3.5 7: × 4 8: × 4.5 9: × 5 A: × 5.5 B: × 6 C: × 7 D: × 8 E: × 9 F: × 10
13	SCBlkSize: Line size of secondary cache 0: 16 words 1: 32 words	

Table 4-1. Mode Setting in Boot Time Mode (2/2)

SysAD	Mode Setting	
	V _R 10000	V _R 12000
14	SCCorEn: ECC error correction of secondary cache data 0: Re-access 1: Always access	
15	MemEnd: Endian 0: Little endian 1: Big endian	
16 : 18	SCSize: Secondary cache size 0: 512K 1: 1M bytes 2: 2M bytes 3: 4M bytes 4: 8M bytes 5: 16M bytes 6 and 7: RFU	
19 : 21	SCClkDiv: Multiple of PClk in respect to SCClk 0: RFU 1: × 1 2: × 1.5 3: × 2 4: × 2.5 5: × 3 6 and 7: RFU	SCClkDiv: Multiple of PClk in respect to SCClk 0: RFU 1: × 1 2: × 1.5 3: × 2 4: × 2.5 5: × 3 6: RFU 7: × 4
22 : 24	RFU	DSD ^{Note 1} : DSD (Delay Speculative Dirty) mode 0 to 3: RFU 4: DSD 5 to 7: RFU
25 : 28	SCClkTap: Internal secondary cache: Phase comparison of clock and SysClk (5:0), $\overline{\text{SysClk}}$ (5:0) 0: Same phase 1: SCClk leads 1/12PClk cycle 2: SCClk leads 2/12PClk cycle 3: SCClk leads 3/12PClk cycle 4: SCClk leads 4/12PClk cycle 5: SCClk leads 5/12PClk cycle 6 and 7: Undefined 8: SCClk leads 6/12PClk cycle 9: SCClk leads 7/12PClk cycle A: SCClk leads 8/12PClk cycle B: SCClk leads 9/12PClk cycle C: SCClk leads 10/12PClk cycle D: SCClk leads 11/12PClk cycle E and F: Undefined	
29	RFU	
30	ODrainSys: Processing of system interface signal ^{Note 2}	
31 : 63	RFU	

Notes 1. Refer to 4.6 DSD (Delay Speculative Dirty) mode.

2. $\overline{\text{SysReq}}$, $\overline{\text{SysRel}}$, SysCmd (11:0), SysCmdPar, SysAD (63: 0), SysADChk (7:0), $\overline{\text{SysVal}}$, SysState (2:0), SysStatePar, SysStateVal, SysCorErr, SysUncErr

4.6 DSD (Delay Speculative Dirty) Mode (V_R12000 only)

The DSD (Delay Speculative Dirty) mode prevents a dirty bit from being set by speculative storing.

Bit 24 in the boot mode coincides with bit 24 of the config register and sets the DSD mode in the kernel mode and supervisor mode. However, the DSD mode can be also executed in the user mode by setting bit 24 of the status register. Bit 24 of the config register is read-only and can be set only during boot time.

When the DSD mode has been set, the dirty bit of the secondary cache block of the V_R12000 are not set until the store instruction has become the oldest instruction in the active list and ready to be executed (the dirty bit may be set by an interrupt (and the store instruction is no longer in the speculative status), but the store instruction is not immediately completed).

4.6.1 DSD mode delay

The DSD mode delays setting of a dirty bit but slightly slows down the processing speed. This slowdown occurs each time a block is refilled from the main memory if it is necessary to set the dirty bit. It takes 10 cycles to set the dirty bit. During this time, the processor executes the other instructions in parallel.

Once a block becomes dirty in the secondary cache, this mode does not affect the performance.

4.6.2 Secondary cache status in DSD mode

The secondary cache in the DSD mode enters the Clean Exclusive status if a miss hit occurs when the store instruction is no longer the oldest instruction in the pipeline.

Because the cache is upgraded to the Clean Exclusive status immediately after a hit occurs in a line in the Shared status, bus manipulation is started in the speculative status (the processing speed relatively slows down).

4.6.3 Other features

The V_R12000 delays loading of the non-coherent cache until this instruction becomes the oldest, regardless of the DSD mode. This is because speculative loading that accesses an address of the xkphys area not mapped as a non-coherent cache may send data to the secondary cache without appropriate coherency check.

5. INTERNAL/EXTERNAL CONTROL FUNCTIONS

5.1 Reset Function

The following three types of reset functions are available:

- Power-ON reset
- Cold reset
- Software reset

Cold reset and software reset are executed with the power turned on.

As a result of reset, the internal status is initialized. However, software reset does not affect the internal clock and secondary cache clock.

5.1.1 Power-ON reset and cold reset

Power-ON reset and cold reset are executed when the $\overline{\text{SysGnt}}$ and $\overline{\text{SysRespVal}}$ signals are deasserted inactive and the $\overline{\text{SysReset}}$ signal is asserted active. During reset, 64-bit data is received from the mode bit, and the internal status of the processor is initialized (for further information, refer to **4.5 BTMC Interface**).

5.1.2 Software reset

Software reset is executed when the $\overline{\text{SysGnt}}$ and $\overline{\text{SysRespVal}}$ signals are deasserted inactive and the $\overline{\text{SysReset}}$ signal is asserted active. As a result, all the statuses of the external interface are initialized, but the internal clock and secondary cache clock continues operating. Like the primary and secondary cache, the contents of the CP0 and FPU registers are retained.

5.2 Interrupt Functions

There are two major types of interrupt requests:

- Maskable interrupt request
- Non-maskable interrupt (NMI) request

(1) Maskable interrupt requests

These interrupts can be masked by using the status register (each interrupt can be serviced independently, or all interrupts can be serviced in batch).

There is no priority assigned to the interrupts.

(a) Hardware interrupt requests (five sources)

These interrupts are acknowledged when the corresponding external interrupt request is issued.

(b) Software interrupt requests (two sources)

These interrupts are acknowledged when the IP0 and IP1 bits of the cause register are set.

(c) Timer interrupt request (1 source)

This interrupt is acknowledged when the IP7 bit of the cause register is set because the value of the count register has become equal to the value of the compare register, or when one of the two performance counters has overflowed.

(2) NMI request (1 source)

This is an interrupt request that cannot be masked and is acknowledged when the $\overline{\text{SysNMI}}$ signal is asserted active.

5.3 JTAG Function

The JTAG boundary scan function is a mechanism to test mutual connections among the V_R10000 and other components, and not to test the processor itself.

As the minimum functions of JTAG, the following functions are provided to the V_R10000. Functionally, however, the V_R10000 only has the external test function of the JTAG boundary scan register.

- TAP controller
- JTAG instruction register
- JTAG bypass register
- JTAG boundary scan register

Table 6-1. CPU Instruction Set: MIPS I (1/2)

Instruction	Description	Format	
Load/store instruction		op	base rt offset
LB	Load Byte	LB	rt, offset (base)
LBU	Load Byte Unsigned	LBU	rt, offset (base)
LH	Load Halfword	LH	rt, offset (base)
LHU	Load Halfword Unsigned	LHU	rt, offset (base)
LW	Load Word	LW	rt, offset (base)
LWL	Load Word Left	LWL	rt, offset (base)
LWR	Load Word Right	LWR	rt, offset (base)
SB	Store Byte	SB	rt, offset (base)
SH	Store Halfword	SH	rt, offset (base)
SW	Store Word	SW	rt, offset (base)
SWL	Store Word Left	SWL	rt, offset (base)
SWR	Store Word Right	SWR	rt, offset (base)
ALU immediate instruction		op	rs rt offset
ADDI	Add Immediate	ADDI	rt, rs, immediate
ADDIU	Add Immediate Unsigned	ADDIU	rt, rs, immediate
SLTI	Set On Less Than Immediate	SLTI	rt, rs, immediate
SLTIU	Set On Less Than Immediate Unsigned	SLTIU	rt, rs, immediate
ANDI	And Immediate	ANDI	rt, rs, immediate
ORI	Or Immediate	ORI	rt, rs, immediate
XORI	Exclusive Or Immediate	XORI	rt, rs, immediate
LUI	Load Upper Immediate	LUI	rt, immediate
3-operand type instruction		op	rs rt rd sa funct
ADD	Add	ADD	rd, rs, rt
ADDU	Add Unsigned	ADDU	rd, rs, rt
SUB	Subtract	SUB	rd, rs, rt
SUBU	Subtract Unsigned	SUBU	rd, rs, rt
SLT	Set On Less Than	SLT	rd, rs, rt
SLTU	Set On Less Than Unsigned	SLTU	rd, rs, rt
AND	And	AND	rd, rs, rt
OR	Or	OR	rd, rs, rt
XOR	Exclusive Or	XOR	rd, rs, rt
NOR	Nor	NOR	rd, rs, rt
Shift instruction		op	rs rt rd sa funct
SLL	Shift Left Logical	SLL	rd, rt, sa
SRL	Shift Right Logical	SRL	rd, rt, sa
SRA	Shift Right Arithmetic	SRA	rd, rt, sa
SLLV	Shift Left Logical Variable	SLLV	rd, rt, rs
SRLV	Shift Right Logical Variable	SRLV	rd, rt, rs
SRAV	Shift Right Arithmetic Variable	SRAV	rd, rt, rs

Table 6-1. CPU Instruction Set: MIPS I (2/2)

Instruction	Description	Format
Multiplication/division instruction		op rs rt rd sa funct
MULT	Multiply	MULT rs, rt
MULTU	Multiply Unsigned	MULTU rs, rt
DIV	Divide	DIV rs, rt
DIVU	Divide Unsigned	DIVU rs, rt
MFHI	Move From HI	MFHI rd
MFLO	Move From LO	MFLO rd
MTHI	Move To HI	MTHI rs
MTLO	Move To LO	MTLO rs
Jump instruction (1)		op target
J	Jump	J target
JAL	Jump And Link	JAL target
Jump instruction (2)		op rs rt rd sa funct
JR	Jump Register	JR rs
JALR	Jump And Link Register	JALR rs JALR rs, rd
Branch instruction (1)		op rs rt offset
BEQ	Branch On Equal	BEQ rs, rt, offset
BNE	Branch On Not Equal	BNE rs, rt, offset
BLEZ	Branch On Less Than Or Equal To Zero	BLEZ rs, offset
BGTZ	Branch On Greater Than Zero	BGTZ rs, offset
Branch instruction (2)		REGIMM rs sub offset
BLTZ	Branch On Less Than Zero	BLTZ rs, offset
BGEZ	Branch On Greater Than Or Equal to Zero	BGEZ rs, offset
BLTZAL	Branch On Less Than Zero And Link	BLTZAL rs, offset
BGEZAL	Branch On Greater Than Or Equal To Zero And Link	BGEZAL rs, offset
Special instruction		SPECIAL rs rt rd sa funct
SYSCALL	System Call	SYSCALL
BREAK	Breakpoint	BREAK
Coprocessor instruction (1)		op base rt offset
LWCz	Load Word To Coprocessor z	LWCz rt, offset (base)
SWCz	Store Word From Coprocessor z	SWCz rt, offset (base)
Coprocessor instruction (2)		COPz CO cofun
COPz	Coprocessor z Operation	COPz cofun

Table 6-2. CPU Instruction Set: MIPS II

Instruction	Description	Format
Load/store instruction	op base rt offset	
LL	Load Linked	LL rt, offset (base)
SC	Store Conditional	SC rt, offset (base)
Branch instruction (1)	op rs rt offset	
BEQL	Branch On Equal Likely	BEQL rs, rt, offset
BNEL	Branch On Not Equal Likely	BNEL rs, rt, offset
BLEZL	Branch On Less Than Or Equal To Zero Likely	BLEZL rs, offset
BGTZL	Branch On Greater Than Zero Likely	BGTZL rs, offset
Branch instruction (2)	REGIMM rs sub offset	
BLTZL	Branch On Less Than Zero Likely	BLTZL rs, offset
BGEZL	Branch On Greater Than Or Equal To Zero Likely	BGEZL rs, offset
BLTZALL	Branch On Less Than Zero And Link Likely	BLTZALL rs, offset
BGEZALL	Branch On Greater Than Or Equal To Zero And Link Likely	BGEZALL rs, offset
Exception instruction	SPECIAL rs rt rd sa funct	
TGE	Trap If Greater Than Or Equal	TGE rs, rt
TGEU	Trap If Greater Than Or Equal Unsigned	TGEU rs, rt
TLT	Trap If Less Than	TLT rs, rt
TLTU	Trap If Less Than Unsigned	TLTU rs, rt
TEQ	Trap If Equal	TEQ rs, rt
TNE	Trap If Not Equal	TNE rs, rt
Exception immediate instruction	REGIMM rs sub immediate	
TGEI	Trap If Greater Than Or Equal Immediate	TGEI rs, immediate
TGEIU	Trap If Greater Than Or Equal Immediate Unsigned	TGEIU rs, immediate
TLTI	Trap If Less Than Immediate	TLTI rs, immediate
TLTIU	Trap If Less Than Immediate Unsigned	TLTIU rs, immediate
TEQI	Trap If Equal Immediate	TEQI rs, immediate
TNEI	Trap If Not Equal Immediate	TNEI rs, immediate
Special instruction	SPECIAL rs rt rd sa funct	
SYNC	Synchronize	SYNC
Coprocessor instruction	op base rt offset	
LDCz	Load Doubleword To Coprocessor z	LDCz rt, offset (base)
SDCz	Store Doubleword From Coprocessor z	SDCz rt, offset (base)

Table 6-3. CPU Instruction Set: MIPS III

Instruction	Description	Format
Load/store instruction		op base rt offset
LD	Load Doubleword	LD rt, offset (base)
LDL	Load Doubleword Left	LDL rt, offset (base)
LDR	Load Doubleword Right	LDR rt, offset (base)
LLD	Load Linked Doubleword	LLD rt, offset (base)
LWU	Load Word Unsigned	LWU rt, offset (base)
SCD	Store Conditional Doubleword	SCD rt, offset (base)
SD	Store Doubleword	SD rt, offset (base)
SDL	Store Doubleword Left	SDL rt, offset (base)
SDR	Store Doubleword Right	SDR rt, offset (base)
ALU immediate instruction		op rs rt immediate
DADDI	Doubleword Add Immediate	DADDI rt, rs, immediate
DADDIU	Doubleword Add Immediate Unsigned	DADDIU rt, rs, immediate
3-operand type instruction		op rs rt rd sa funct
DADD	Doubleword Add	DADD rd, rs, rt
DADDU	Doubleword Add Unsigned	DADDU rd, rs, rt
DSUB	Doubleword Subtract	DSUB rd, rs, rt
DSUBU	Doubleword Subtract Unsigned	DSUBU rd, rs, rt
Shift instruction		op rs rt rd sa funct
DSLL	Doubleword Shift Left Logical	DSLL rd, rt, sa
DSRL	Doubleword Shift Right Logical	DSRL rd, rt, sa
DSRA	Doubleword Shift Right Arithmetic	DSRA rd, rt, sa
DSLLV	Doubleword Shift Left Logical Variable	DSLLV rd, rt, rs
DSRLV	Doubleword Shift Right Logical Variable	DSRLV rd, rt, rs
DSRAV	Doubleword Shift Right Arithmetic Variable	DSRAV rd, rt, rs
DSLL32	Doubleword Shift Left Logical + 32	DSLL32 rd, rt, sa
DSRL32	Doubleword Shift Right Logical + 32	DSRL32 rd, rt, sa
DSRA32	Doubleword Shift Right Arithmetic +32	DSRA32 rd, rt, sa
Multiplication/division instruction		op rs rt rd sa funct
DMULT	Doubleword Multiply	DMULT rs, rt
DMULTU	Doubleword Multiply Unsigned	DMULTU rs, rt
DDIV	Doubleword Divide	DDIV rs, rt
DDIVU	Doubleword Divide Unsigned	DDIVU rs, rt

Table 6-4. CPU Instruction Set: MIPS IV

Instruction	Description	Format
3-operand type instruction		op rs rt rd sa funct
MOVN	Move Conditional On Not Zero	MOVN rd, rs, rt
MOVZ	Move Conditional On Zero	MOVZ rd, rs, rt
Prefetch instruction		op base hint offset
PREF	Prefetch	PREF hint, offset (base)

6.3 FPU Instruction Set List

All the FPU instructions are 32 bits long and located at a word boundary.

Tables 6-5 through 6-8 list the FPU instruction set.

Table 6-5. FPU Instruction Set: MIPS I

Instruction	Description	Format
Load/store instruction		op base ft offset
LWC1	Load Word To FPU	LWC1 ft, offset (base)
SWC1	Store Word From FPU	SWC1 ft, offset (base)
Transfer instruction		COP1 sub rt fs 0
MTC1	Move Word To FPU	MTC1 rt, fs
MFC1	Move Word From FPU	MFC1 rt, fs
CTC1	Move Control Word To FPU	CTC1 rt, fs
CFC1	Move Control Word From FPU	CFC1 rt, fs
Conversion instruction		COP1 fmt 0 fs fd funct
CVT.S.fmt	Floating-point Convert To Single Floating-point Format	CVT.S.fmt fd, fs
CVT.D.fmt	Floating-point Convert To Double Floating-point Format	CVT.D.fmt fd, fs
CVT.W.fmt	Floating-point Convert To Single Fixed-point Format	CVT.W.fmt fd, fs
Operation instruction		COP1 fmt ft fs fd funct
ADD.fmt	Floating-point Add	ADD.fmt fd, fs, ft
SUB.fmt	Floating-point Subtract	SUB.fmt fd, fs, ft
MUL.fmt	Floating-point Multiply	MUL.fmt fd, fs, ft
DIV.fmt	Floating-point Divide	DIV.fmt fd, fs, ft
ABS.fmt	Floating-point Absolute Value	ABS.fmt fd, fs
MOV.fmt	Floating-point Move	MOV.fmt fd, fs
NEG.fmt	Floating-point Negate	NEG.fmt fd, fs
Compare instruction		COP1 fmt ft fs cc 0 funct
C.cond.fmt	Floating-point Compare	C.cond.fmt cc, fs, ft
FPU branch instruction		COP1 BC cc 0 offset
BC1T	Branch On FPU True	BC1T cc, offset
BC1F	Branch On FPU False	BC1F cc, offset

Table 6-6. FPU Instruction Set: MIPS II

Instruction	Description	Format
Load/store instruction	op base ft offset	
LDC1	Load Doubleword To FPU	LDC1 ft, offset (base)
SDC1	Store Doubleword From FPU	SDC1 ft, offset (base)
Conversion instruction	COP1 fmt 0 fs fd funct	
ROUND.W.fmt	Floating-point Round To Single Fixed-point Format	ROUND.W.fmt fd, fs
TRUNC.W.fmt	Floating-point Truncate To Single Fixed-point Format	TRUNC.W.fmt fd, fs
CEIL.W.fmt	Floating-point Ceiling To Single Fixed-point Format	CEIL.W.fmt fd, fs
FLOOR.W.fmt	Floating-point Floor To Single Fixed-point Format	FLOOR.W.fmt fd, fs
Operation instruction	COP1 fmt ft fs fd funct	
SQRT.fmt	Floating-point Square Root	SQRT.fmt fd, fs
FPU branch instruction	COP1 BC cc 0 offset	
BC1TL	Branch On FPU True Likely	BC1TL cc, offset
BC1FL	Branch On FPU False Likely	BC1FL cc, offset

Table 6-7. FPU Instruction Set: MIPS III

Instruction	Description	Format
Transfer instruction	COP1 sub rt fs 0	
DMTC1	Doubleword Move To FPU	DMTC1 rt, fs
DMFC1	Doubleword Move From FPU	DMFC1 rt, fs
Conversion instruction	COP1 fmt 0 fs fd funct	
CVT.S.fmt	Floating-point Convert To Single Floating-point Format	CVT.S.fmt fd, fs
CVT.D.fmt	Floating-point Convert To Double Floating-point Format	CVT.D.fmt fd, fs
CVT.L.fmt	Floating-point Convert To Long Fixed-point Format	CVT.L.fmt fd, fs
ROUND.L.fmt	Floating-point Round To Long Fixed-point Format	ROUND.L.fmt fd, fs
TRUNC.L.fmt	Floating-point Truncate To Long Fixed-point Format	TRUNC.L.fmt fd, fs
CEIL.L.fmt	Floating-point Ceiling To Long Fixed-point Format	CEIL.L.fmt fd, fs
FLOOR.L.fmt	Floating-point Floor To Long Fixed-point Format	FLOOR.L.fmt fd, fs

Table 6-8. FPU Instruction Set: MIPS IV

Instruction	Description	Format
Load index instruction	op base index 0	fd funct
LWXC1	Load Word Indexed To Floating-point	LWXC1 fd, index (base)
LDXC1	Load Doubleword Indexed To Floating-point	LDXC1 fd, index (base)
Store index instruction	op base index fs 0	funct
SWXC1	Store Word Indexed From Floating-point	SWXC1 fs, index (base)
SDXC1	Store Doubleword Indexed From Floating-point	SDXC1 fs, index (base)
Conversion instruction	COP1 fmt 0 fs	fd funct
RECIP.fmt	Reciprocal Approximation	RECIP.fmt fd, fs
RSQRT.fmt	Reciprocal Square Root Approximation	RSQRT.fmt fd, fs
Multiplication instruction (1)	COP1 fmt ft fs	fd funct
MSUB.fmt	Floating-point Multiply Subtract	MSUB.fmt fd, fr, fs, ft
NMSUB.fmt	Floating-point Negative Multiply Subtract	NMSUB.fmt fd, fr, fs, ft
MADD.fmt	Floating-point Multiply Add	MADD.fmt fd, fr, fs, ft
NMADD.fmt	Floating-point Negative Multiply Add	NMADD.fmt fd, fr, fs, ft
MOVN.fmt	Floating-point Move Conditional On Not Zero	MOVN.fmt fd, fs, ft
MOVZ.fmt	Floating-point Move Conditional On Zero	MOVZ.fmt fd, fs, ft
Operation instruction (2)	COP1 fmt cc 0 fs	fd funct
MOVF.fmt	Floating-point Move Conditional On FPU False	MOVF.fmt fd, fs, cc
MOVT.fmt	Floating-point Move Conditional On FPU True	MOVT.fmt fd, fs, cc
Compare instruction	COP1 fmt ft fs	cc 0 funct
C.cond.fmt	Floating-point Compare	C.cond.fmt cc, fs, ft
FPU branch instruction	COP1 BC cc 0	offset
BC1T	Branch On FPU True	BC1T cc, offset
BC1F	Branch On FPU False	BC1F cc, offset
BC1TL	Branch On FPU True Likely	BC1TL cc, offset
BC1FL	Branch On FPU False Likely	BC1FL cc, offset
Conditional transfer instruction	op rs cc tf rd	funct
MOVF	Move Conditional On FPU False	MOVF rd, rs, cc
MOVT	Move Conditional On FPU True	MOVT rd, rs, cc
Prefetch instruction	op base index hint 0	funct
PREFX	Prefetch Indexed	PREFX hint, index (base)

6.4 Delay of Instruction

(1) Delay of integer instructions

Table 6-9 shows execution delay of the integer instructions.

For details of each instruction, refer to **VR5000, VR10000 User's Manual – Instruction**.

Table 6-9. Integer Operation Instruction Delay Time

Instruction Type	Execution Unit	PClk	Repeat Rate	Remark
ADD, SET, SUB, Logical	ALU1, ALU2	1	1	
MFHI, MTHI, MFLO, MTLO		1	1	
Shift, LUI	ALU1	1	1	
Conditional Branch		1	1	
Conditional Move		1	1	
MULT	ALU2	5/6	6	Delay of LO/HI
MULTU		6/7	7	Delay of LO/HI
DMULT		9/10	10	Delay of LO/HI
DMULTU		10/11	11	Delay of LO/HI
DIV, DIVU		34/35	35	Delay of LO/HI
DDIV, DDIVU		66/67	67	Delay of LO/HI
Load (except for CP1 instruction)		Load/store	2	1
Store	—		1	In the case of cache hit

(2) Delay of floating-point instructions

Table 6-10 shows the execution delay of the floating-point instruction.

For details of each instruction, refer to **VR5000, VR10000 User's Manual – Instruction**.

Table 6-10. Floating-Point Instruction Delay Time

Instruction Type	Execution Unit	PClk	Repeat Rate	Remark
MTC1, DMTC1	ALU1	3	1	
ADD, SUB, ABS, NEG, ROUND, TRUNC, CEIL, FLOOR, C.cond	Fp adder	2	1	
CVT.S.W, CVT.S.L		4	2	Average value of repeat rate
CVT (other than above)		2	1	
MUL	Fp multiplier	2	1	
MFC1, DMFC1		2	1	
Conditional MOVE/CVT.S.L		2	1	
DIV.S, RECIP.S		12	14	
DIV.D, RECIP.D		19	21	
SQRT.S		18	20	
SQRT.D		33	35	
RSQRT.S		30	20	
RSQRT.D		52	35	
MADD		Fp adder + Fp multiplier	2/4	1
LWC1, LDC1, LWXC1, LDXC1	Load/store	3	1	In the case of cache hit

7. ELECTRICAL SPECIFICATIONS

(1) μPD30700RS-180 and 30700RS-200

Absolute Maximum Ratings (T_A = 25 °C)

Parameter	Symbol	Condition	Rating	Unit
Supply voltage	V _{DD}		-0.5 to +3.8	V
Input voltage	V _I		-0.5 to V _{DD} + 0.3	V
		Pulse of less than 10 ns	-1.5 to V _{DD} + 0.3	V
Storage temperature	T _{stg}		-40 to +125	°C

- Cautions**
1. Do not short-circuit two or more outputs at the same time.
 2. If any of the parameters exceeds the absolute maximum ratings, even momentarily, the quality of the product may be impaired. The absolute maximum ratings are values that may physically damage the product(s). Use the product(s) with these rated values never exceeded. The specifications and conditions shown in DC Characteristics and AC Characteristics below are the range in which the product(s) operate normally and the quality of the product is guaranteed.

Operating Case Temperature (V_{DD} = 3.3 V ±0.165 V)

Parameter	Symbol	Condition	Rating	Unit
Operating case temperature	T _C		0 to 70	°C

DC Characteristics (T_c = 0 to 70 °C, V_{DD} = 3.3 V ±0.165 V)

(a) Common to CMOS/TTL and HSTL

Parameter	Symbol	Condition	MIN.	MAX.	Unit
Input capacitance	C _{in}			5	pF
Output capacitance	C _{out}			7	pF
Power consumption	P _D	200 MHz (V _{DD} = 3.3 V)		30	W
		180 MHz (V _{DD} = 3.3 V)		27	W
Input leakage power	I _{LI}			±10	μA
I/O leakage current	I _{LIO}			±10	μA

(b) CMOS/TTL

Parameter	Symbol	Condition	MIN.	MAX.	Unit
Output supply voltage ^{Note 1}	V _{DDQ}	V _{DDQ} = V _{DD}	3.135	3.465	V
Input supply voltage ^{Note 2}	V _{REF}		1.2	1.6	V
High-level output voltage	V _{OH}	V _{DD} = MIN., I _{OH} = -4 mA	2.4		V
Low-level output voltage	V _{OL}	V _{DD} = MAX., I _{OL} = 4 mA		0.4	V
High-level input voltage	V _{IH}		2.0	V _{DD} + 0.3	V
Low-level input voltage	V _{IL}		-0.5	+0.8	V

- Notes** 1. V_{DDQ} is applied to the V_{DDQSC} and V_{DDQSys} pins.
 2. V_{REF} is applied to the V_{refSC} and V_{refSys} pins.

(c) HSTL

Parameter	Symbol	Condition	MIN.	MAX.	Unit
Output supply voltage ^{Note 1}	V _{DDQ}		1.4	1.6	V
Input supply voltage ^{Note 2}	V _{REF}		0.65	0.75	V
High-level output threshold voltage ^{Note 3}	V _{OH}	I _{OH} = -4 mA	V _{DDQ} /2 + 0.3		V
Low-level output threshold voltage ^{Note 3}	V _{OL}	I _{OL} = 4 mA		V _{DDQ} /2 - 0.3	V
High-level differential input threshold voltage 1 ^{Note 4}	V _{IH}		V _{REF} + 0.1	V _{DD} + 0.3	V
Low-level differential input threshold voltage 1 ^{Note 4}	V _{IL}		-0.3	V _{DD} - 0.1	V
High-level differential input threshold voltage 2 ^{Note 5}	V _{DIH}		V _{DIL} + 0.8	V _{DD} + 0.3	V
Low-level differential input threshold voltage 2 ^{Note 5}	V _{DIL}		-0.3	V _{DIH} - 0.8	V

- Notes** 1. V_{DDQ} is applied to the V_{DDQSC} and V_{DDQSys} pins.
 2. V_{REF} is applied to the V_{refSC} and V_{refSys} pins.
 3. The Vr10000 supports 1a and 1b of the HSTL specifications of SGI.
 4. Applied to the input pins other than SysClk and $\overline{\text{SysClk}}$.
 5. Applied to the SysClk and $\overline{\text{SysClk}}$ pins.

AC Characteristics (T_C = 0 to 70 °C, V_{DD} = 3.3 V ±0.165 V)

Clock parameter

Parameter	Symbol	Condition	MIN.	MAX.	Unit
System clock high-level width	t _{CH}	t _{CR} , t _{CF} ≤ 2.0 ns	0.5		ns
System clock low-level width	t _{CL}	t _{CR} , t _{CF} ≤ 2.0 ns	0.5		ns
System clock frequency ^{Notes 1,2}		200-MHz model	50	200	MHz
		180-MHz model	45	180	MHz
System clock cycle ^{Notes 1,2}	t _{CP}	200-MHz model	5	20	ns
		180-MHz model	5.56	22.2	ns
Input system clock jitter	t _{ji}			±125	ps
Output system clock jitter ^{Note 3}	t _{jo}			±500	ps
System clock rise time	t _{CR}			2.0	ns
System clock fall time	t _{CF}			2.0	ns

- Notes**
1. The operation of the V_R10000 is guaranteed only when PLL operates.
 2. The operation is guaranteed when the internal operating frequency is 100 MHz or higher.
 3. Changes between clock edges are undefined.

System Interface Parameter

(a) CMOS/TTL

Parameter	Symbol	Condition	MIN.	MAX.	Unit
Data output delay time	t _{DO}			2.0	ns
Data input setup time	t _{DS}		1.0		ns
Data input hold time	t _{DH}		1.0		ns

(b) HSTL

Parameter	Symbol	Condition	MIN.	MAX.	Unit
Data output delay time	t _{DO}			1.5	ns
Data input setup time	t _{DS}		1.0		ns
Data input hold time	t _{DH}		1.0		ns

Secondary Cache Tag Interface Parameter

Applied to SCTag (25:0) and SCTagChk (6:0)

(a) CMOS/TTL

Parameter	Symbol	Condition	MIN.	MAX.	Unit
Data output delay time	t _{SDO}			2.0	ns
Data input setup time	t _{SDS}		1.5		ns
Data input hold time	t _{SDH}		0.5		ns

(b) HSTL

Parameter	Symbol	Condition	MIN.	MAX.	Unit
Data output delay time	t _{SDO}			1.5	ns
Data input setup time	t _{SDS}		1.5		ns
Data input hold time	t _{SDH}		0.5		ns

(2) μPD30700LRS-225 and 30700LRS-250 (preliminary)

Absolute Maximum Ratings (T_A = 25 °C)

Parameter	Symbol	Condition	Rating	Unit
Supply voltage	V _{DD}		-0.5 to +3.3	V
Input voltage	V _I		-0.5 to V _{DD} + 0.3	V
		Pulse of less than 10 ns	-1.5 to V _{DD} + 0.3	V
Storage temperature	T _{stg}		-40 to +125	°C

- Cautions**
1. Do not short-circuit two or more outputs at the same time.
 2. If any of the parameters exceeds the absolute maximum ratings, even momentarily, the quality of the product may be impaired. The absolute maximum ratings are values that may physically damage the product(s). Use the product(s) with these rated values never exceeded. The specifications and conditions shown in DC Characteristics and AC Characteristics below are the range in which the product(s) operate normally and the quality of the product is guaranteed.

Operating Case Temperature (V_{DD} = 2.6 V ±0.1 V)

Parameter	Symbol	Condition	Rating	Unit
Operating case temperature	T _C		0 to 70	°C

DC Characteristics (T_c = 0 to 70 °C, V_{DD} = 2.6 V ±0.1 V)

(a) Common to CMOS/TTL and HSTL

Parameter	Symbol	Condition	MIN.	MAX.	Unit
Input capacitance	C _{in}			5	pF
Output capacitance	C _{out}			7	pF
Power consumption	P _D	250 MHz (V _{DD} = 2.6 V)		20	W
		225 MHz (V _{DD} = 2.6 V)		17	W
Input leakage power	I _{LI}			±10	μA
I/O leakage current	I _{LIO}			±10	μA

(b) CMOS/TTL

Parameter	Symbol	Condition	MIN.	MAX.	Unit
Output supply voltage ^{Note 1}	V _{DDQ}	V _{DDQ} = V _{DD}	2.5	2.7	V
Input supply voltage ^{Note 2}	V _{REF}		1.2	1.6	V
High-level output voltage	V _{OH}	V _{DD} = MIN., I _{OH} = -4 mA	2.4		V
Low-level output voltage	V _{OL}	V _{DD} = MAX., I _{OL} = 4 mA		0.4	V
High-level input voltage	V _{IH}		2.0	V _{DD} + 0.3	V
Low-level input voltage	V _{IL}		-0.5	+0.8	V

- Notes** 1. V_{DDQ} is applied to the V_{DDQ}SC and V_{DDQ}Sys pins.
 2. V_{REF} is applied to the V_{ref}SC and V_{ref}Sys pins.

(c) HSTL

Parameter	Symbol	Condition	MIN.	MAX.	Unit
Output supply voltage ^{Note 1}	V _{DDQ}		1.4	1.6	V
Input supply voltage ^{Note 2}	V _{REF}		0.65	0.75	V
High-level output threshold voltage ^{Note 3}	V _{OH}	I _{OH} = -4 mA	V _{DDQ} /2 + 0.3		V
Low-level output threshold voltage ^{Note 3}	V _{OL}	I _{OL} = 4 mA		V _{DDQ} /2 - 0.3	V
High-level differential input threshold voltage 1 ^{Note 4}	V _{IH}		V _{REF} + 1	V _{DD} + 0.3	V
Low-level differential input threshold voltage 1 ^{Note 4}	V _{IL}		-0.3	V _{DD} - 0.1	V
High-level differential input threshold voltage 2 ^{Note 5}	V _{DIH}		V _{DIL} + 0.8	V _{DD} + 0.3	V
Low-level differential input threshold voltage 2 ^{Note 5}	V _{DIL}		-0.3	V _{DIH} - 0.8	V

- Notes** 1. V_{DDQ} is applied to the V_{DDQ}SC and V_{DDQ}Sys pins.
 2. V_{REF} is applied to the V_{ref}SC and V_{ref}Sys pins.
 3. The Vr10000 supports 1a and 1b of the HSTL specifications of SGI.
 4. Applied to the input pins other than SysClk and $\overline{\text{SysClk}}$.
 5. Applied to the SysClk and $\overline{\text{SysClk}}$ pins.

AC Characteristics (T_C = 0 to 70 °C, V_{DD} = 2.6 V ±0.1 V)

Clock parameter

Parameter	Symbol	Condition	MIN.	MAX.	Unit
System clock high-level width	t _{CH}	t _{CR} , t _{CF} ≤ 2.0 ns	0.5		ns
System clock low-level width	t _{CL}	t _{CR} , t _{CF} ≤ 2.0 ns	0.5		ns
System clock frequency ^{Notes 1, 2}		250-MHz model	62.5	250	MHz
		225-MHz model	56.3	225	MHz
System clock cycle ^{Notes 1, 2}	t _{CP}	250-MHz model	4	16	ns
		225-MHz model	4.44	17.8	ns
Input system clock jitter	t _{ji}			±125	ps
Output system clock jitter ^{Note 3}	t _{jo}			±500	ps
System clock rise time	t _{CR}			2.0	ns
System clock fall time	t _{CF}			2.0	ns

- Notes**
1. The operation of the V_R10000 is guaranteed only when PLL operates.
 2. The operation is guaranteed when the internal operating frequency is 100 MHz or higher.
 3. Changes between clock edges are undefined.

System Interface Parameter

(a) CMOS/TTL

Parameter	Symbol	Condition	MIN.	MAX.	Unit
Data output delay time	t _{DO}			2.0	ns
Data input setup time	t _{DS}		1.0		ns
Data input hold time	t _{DH}		1.0		ns

(b) HSTL

Parameter	Symbol	Condition	MIN.	MAX.	Unit
Data output delay time	t _{DO}			1.5	ns
Data input setup time	t _{DS}		1.0		ns
Data input hold time	t _{DH}		1.0		ns

Secondary Cache Tag Interface Parameter

Applied to SCTag (25:0) and SCTagChk (6:0)

(a) CMOS/TTL

Parameter	Symbol	Condition	MIN.	MAX.	Unit
Data output delay time	t _{SDO}			2.0	ns
Data input setup time	t _{SDS}		1.5		ns
Data input hold time	t _{SDH}		0.5		ns

(b) HSTL

Parameter	Symbol	Condition	MIN.	MAX.	Unit
Data output delay time	t _{SDO}			1.5	ns
Data input setup time	t _{SDS}		1.5		ns
Data input hold time	t _{SDH}		0.5		ns

(3) μPD30710RS-300 (preliminary)

Absolute Maximum Ratings (T_A = 25 °C)

Parameter	Symbol	Condition	Rating	Unit
Supply voltage	V _{DD}		-0.5 to +3.3	V
Input voltage	V _I		-0.5 to V _{DD} + 0.3	V
		Pulse of less than 10 ns	-1.5 to V _{DD} + 0.3	V
Storage temperature	T _{stg}		-40 to +125	°C

- Cautions**
1. Do not short-circuit two or more outputs at the same time.
 2. If any of the parameters exceeds the absolute maximum ratings, even momentarily, the quality of the product may be impaired. The absolute maximum ratings are values that may physically damage the product(s). Use the product(s) with these rated values never exceeded. The specifications and conditions shown in DC Characteristics and AC Characteristics below are the range in which the product(s) operate normally and the quality of the product is guaranteed.

Operating Case Temperature (V_{DD} = 2.6 V ±0.1 V)

Parameter	Symbol	Condition	Rating	Unit
Operating case temperature	T _C		25 to 70	°C

DC Characteristics (T_c = 25 to 70 °C, V_{DD} = 2.6 V ±0.1 V)

(a) Common to CMOS/TTL and HSTL

Parameter	Symbol	Condition	MIN.	MAX.	Unit
Input capacitance	C _{in}			5	pF
Output capacitance	C _{out}			7	pF
Power consumption	P _D	300 MHz (V _{DD} = 2.6 V)		30	W
Input leakage power	I _{LI}			±10	μA
I/O leakage current	I _{LIO}			±10	μA

(b) CMOS/TTL

Parameter	Symbol	Condition	MIN.	MAX.	Unit
Output supply voltage ^{Note 1}	V _{DDQ}	V _{DDQ} = V _{DD}	2.5	2.7	V
Input supply voltage ^{Note 2}	V _{REF}		1.2	1.6	V
High-level output voltage	V _{OH}	V _{DD} = MIN., I _{OH} = -4 mA	2.4		V
Low-level output voltage	V _{OL}	V _{DD} = MAX., I _{OL} = 4 mA		0.4	V
High-level input voltage	V _{IH}		2.0	V _{DD} + 0.3	V
Low-level input voltage	V _{IL}		-0.5	+0.8	V

- Notes**
1. V_{DDQ} is applied to the V_{DDQSC} and V_{DDQSys} pins.
 2. V_{REF} is applied to the V_{refSC} and V_{refSys} pins.

(c) HSTL

Parameter	Symbol	Condition	MIN.	MAX.	Unit
Output supply voltage ^{Note 1}	V _{DDQ}		1.4	1.6	V
Input supply voltage ^{Note 2}	V _{REF}		0.65	0.75	V
High-level output threshold voltage ^{Note 3}	V _{OH}	I _{OH} = -4 mA	V _{DDQ} /2 + 0.3		V
Low-level output threshold voltage ^{Note 3}	V _{OL}	I _{OL} = 4 mA		V _{DDQ} /2 - 0.3	V
High-level differential input threshold voltage 1 ^{Note 4}	V _{IH}		V _{REF} + 0.1	V _{DD} + 0.3	V
Low-level differential input threshold voltage 1 ^{Note 4}	V _{IL}		-0.3	V _{DD} - 0.1	V
High-level differential input threshold voltage 2 ^{Note 5}	V _{DIH}		V _{DIL} + 0.8	V _{DD} + 0.3	V
Low-level differential input threshold voltage 2 ^{Note 5}	V _{DIL}		-0.3	V _{DIH} - 0.8	V

- Notes**
1. V_{DDQ} is applied to the V_{DDQSC} and V_{DDQSys} pins.
 2. V_{REF} is applied to the V_{refSC} and V_{refSys} pins
 3. The VR12000 supports 1a and 1b of the HSTL specifications of SGI.
 4. Applied to the input pins other than SysClk and $\overline{\text{SysClk}}$.
 5. Applied to the SysClk and $\overline{\text{SysClk}}$ pins.

AC Characteristics (T_C = 25 to 70 °C, V_{DD} = 2.6 V ±0.1 V)

Clock parameter

Parameter	Symbol	Condition	MIN.	MAX.	Unit
System clock high-level width	t _{CH}	t _{CR} , t _{CF} ≤ 2.0 ns	0.5		ns
System clock low-level width	t _{CL}	t _{CR} , t _{CF} ≤ 2.0 ns	0.5		ns
System clock frequency ^{Notes 1, 2}		300-MHz model	30	300	MHz
System clock cycle ^{Notes 1, 2}	t _{CP}	300-MHz model	3.33	33.3	ns
Input system clock jitter	t _{ji}			±125	ps
Output system clock jitter ^{Note 3}	t _{jo}			±500	ps
System clock rise time	t _{CR}			2.0	ns
System clock fall time	t _{CF}			2.0	ns

- Notes**
1. The operation of the V_R12000 is guaranteed only when PLL operates.
 2. The operation is guaranteed when the internal operating frequency is 100 MHz or higher.
 3. Changes between clock edges are undefined.

System Interface Parameter

(a) CMOS/TTL

Parameter	Symbol	Condition	MIN.	MAX.	Unit
Data output delay time	t _{DO}			2.0	ns
Data input setup time	t _{DS}		1.0		ns
Data input hold time	t _{DH}		1.0		ns

(b) HSTL

Parameter	Symbol	Condition	MIN.	MAX.	Unit
Data output delay time	t _{DO}			1.5	ns
Data input setup time	t _{DS}		1.0		ns
Data input hold time	t _{DH}		1.0		ns

Secondary Cache Tag Interface Parameter

Applied to SCTag (25:0) and SCTagChk (6:0)

(a) CMOS/TTL

Parameter	Symbol	Condition	MIN.	MAX.	Unit
Data output delay time	t _{SDO}			2.0	ns
Data input setup time	t _{SDS}		1.5		ns
Data input hold time	t _{SDH}		0.5		ns

(b) HSTL

Parameter	Symbol	Condition	MIN.	MAX.	Unit
Data output delay time	t _{SDO}			1.5	ns
Data input setup time	t _{SDS}		1.5		ns
Data input hold time	t _{SDH}		0.5		ns

Timing Chart

Secondary Cache Interface Timing

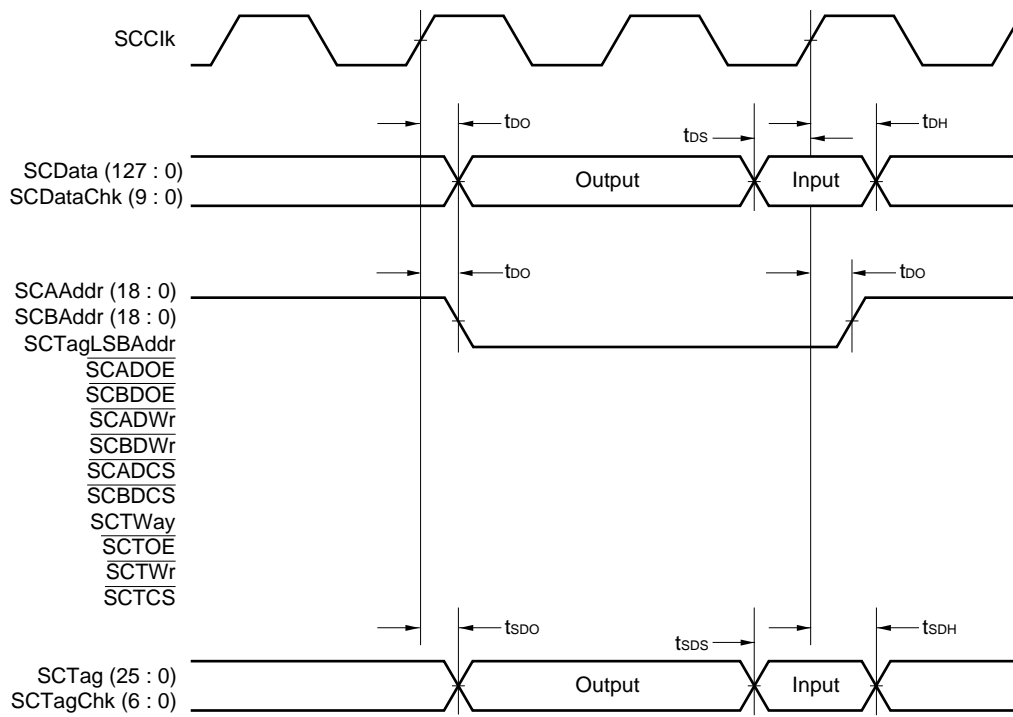

Secondary cache clock jitter

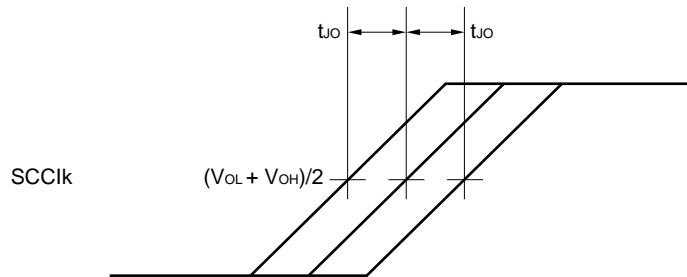

System Interface Timing

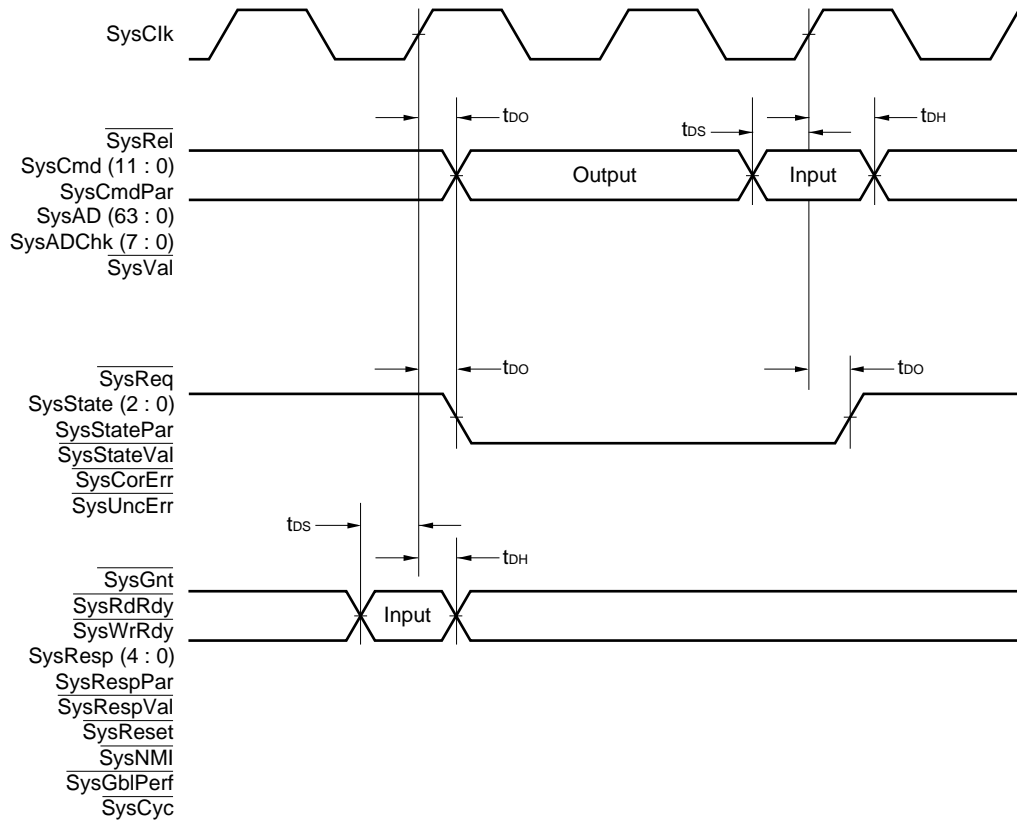

System Clock

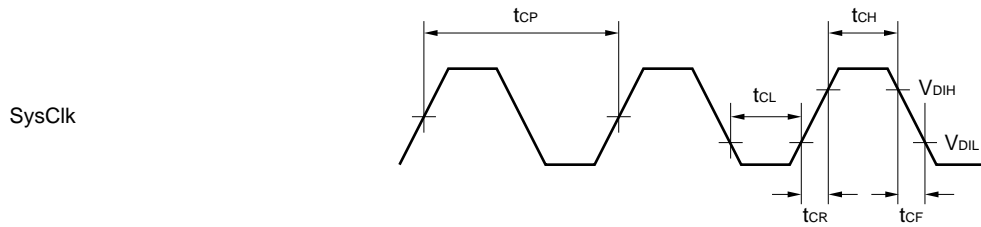

System Clock Jitter

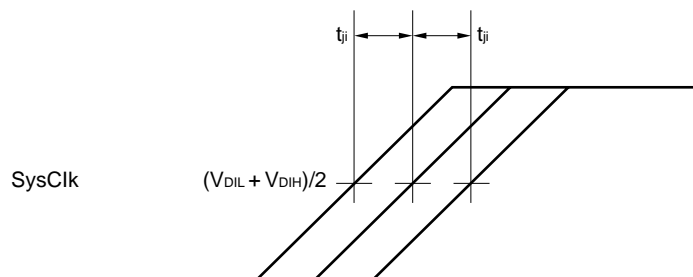

8. PUSH-PULL OUTPUT BUFFER CIRCUIT

The configuration of the push-pull output buffer circuit is shown below.

Push-pull output buffer circuit (without load of termination)

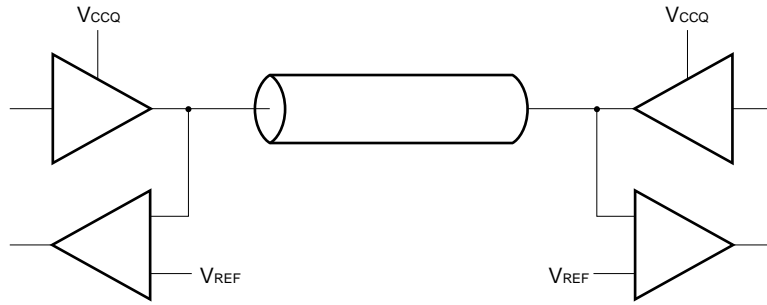

Push-pull output buffer circuit (with load of termination)

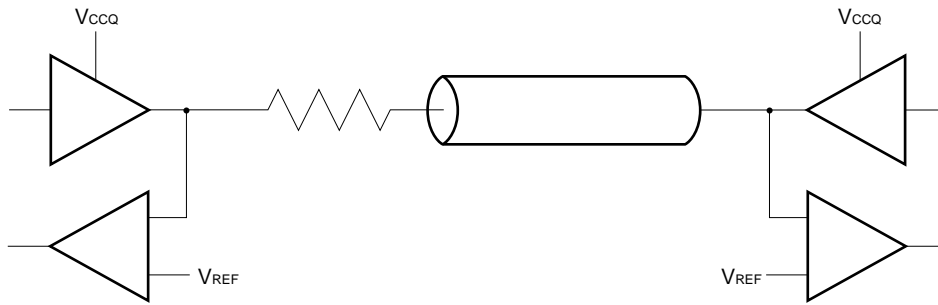

9. PACKAGE DRAWING

599 PIN CERAMIC LGA

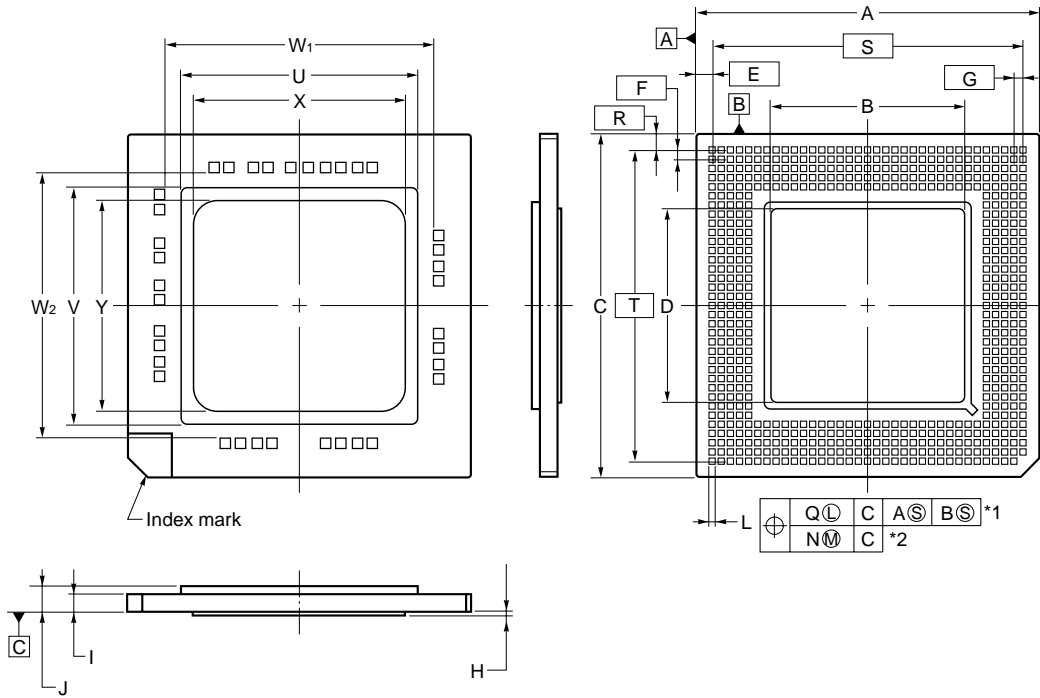

NOTE

*1 Each land centerline is located within 0.30 mm (0.012 inch) of its true position (T.P.) at least material condition.

*2 Each land centerline is located within 0.20 mm (0.008 inch) of its true position (T.P.) at maximum material condition.

ITEM	MILLIMETERS	INCHES
A	47.50±0.25	1.870±0.010
B	29.00	1.142
C	47.50±0.25	1.870±0.010
D	29.00	1.142
E	2.16	0.085
F	1.27 (T.P.)	0.050 (T.P.)
G	1.27 (T.P.)	0.050 (T.P.)
H	0.70 MAX.	0.028 MAX.
I	2.54±0.25	0.100±0.010
J	3.81±0.38	0.150±0.015
L	□0.76±0.13	□0.030 ^{+0.005} _{-0.006}
N	0.20	0.008
Q	0.30	0.012
R	2.16	0.085
S	43.18	1.700
T	43.18	1.700
U	32.54	1.281
V	32.54	1.281
W ₁	37.00	1.457
W ₂	37.00	1.457
X	30.00	1.181
Y	30.00	1.181

X599RS-50A

NOTES FOR CMOS DEVICES

① PRECAUTION AGAINST ESD FOR SEMICONDUCTORS

Note: Strong electric field, when exposed to a MOS device, can cause destruction of the gate oxide and ultimately degrade the device operation. Steps must be taken to stop generation of static electricity as much as possible, and quickly dissipate it once, when it has occurred. Environmental control must be adequate. When it is dry, humidifier should be used. It is recommended to avoid using insulators that easily build static electricity. Semiconductor devices must be stored and transported in an anti-static container, static shielding bag or conductive material. All test and measurement tools including work bench and floor should be grounded. The operator should be grounded using wrist strap. Semiconductor devices must not be touched with bare hands. Similar precautions need to be taken for PW boards with semiconductor devices on it.

② HANDLING OF UNUSED INPUT PINS FOR CMOS

Note: No connection for CMOS device inputs can be cause of malfunction. If no connection is provided to the input pins, it is possible that an internal input level may be generated due to noise, etc., hence causing malfunction. CMOS device behave differently than Bipolar or NMOS devices. Input levels of CMOS devices must be fixed high or low by using a pull-up or pull-down circuitry. Each unused pin should be connected to V_{DD} or GND with a resistor, if it is considered to have a possibility of being an output pin. All handling related to the unused pins must be judged device by device and related specifications governing the devices.

③ STATUS BEFORE INITIALIZATION OF MOS DEVICES

Note: Power-on does not necessarily define initial status of MOS device. Production process of MOS does not define the initial operation status of the device. Immediately after the power source is turned ON, the devices with reset function have not yet been initialized. Hence, power-on does not guarantee out-pin levels, I/O settings or contents of registers. Device is not initialized until the reset signal is received. Reset operation must be executed immediately after power-on for devices having reset function.

Regional Information

Some information contained in this document may vary from country to country. Before using any NEC product in your application, please contact the NEC office in your country to obtain a list of authorized representatives and distributors. They will verify:

- Device availability
- Ordering information
- Product release schedule
- Availability of related technical literature
- Development environment specifications (for example, specifications for third-party tools and components, host computers, power plugs, AC supply voltages, and so forth)
- Network requirements

In addition, trademarks, registered trademarks, export restrictions, and other legal issues may also vary from country to country.

NEC Electronics Inc. (U.S.)

Santa Clara, California
Tel: 408-588-6000
800-366-9782
Fax: 408-588-6130
800-729-9288

NEC Electronics (Germany) GmbH

Duesseldorf, Germany
Tel: 0211-65 03 02
Fax: 0211-65 03 490

NEC Electronics (UK) Ltd.

Milton Keynes, UK
Tel: 01908-691-133
Fax: 01908-670-290

NEC Electronics Italiana s.r.l.

Milano, Italy
Tel: 02-66 75 41
Fax: 02-66 75 42 99

NEC Electronics (Germany) GmbH

Benelux Office
Eindhoven, The Netherlands
Tel: 040-2445845
Fax: 040-2444580

NEC Electronics (France) S.A.

Velizy-Villacoublay, France
Tel: 01-30-67 58 00
Fax: 01-30-67 58 99

NEC Electronics (France) S.A.

Spain Office
Madrid, Spain
Tel: 01-504-2787
Fax: 01-504-2860

NEC Electronics (Germany) GmbH

Scandinavia Office
Taebly, Sweden
Tel: 08-63 80 820
Fax: 08-63 80 388

NEC Electronics Hong Kong Ltd.

Hong Kong
Tel: 2886-9318
Fax: 2886-9022/9044

NEC Electronics Hong Kong Ltd.

Seoul Branch
Seoul, Korea
Tel: 02-528-0303
Fax: 02-528-4411

NEC Electronics Singapore Pte. Ltd.

United Square, Singapore 1130
Tel: 65-253-8311
Fax: 65-250-3583

NEC Electronics Taiwan Ltd.

Taipei, Taiwan
Tel: 02-719-2377
Fax: 02-719-5951

NEC do Brasil S.A.

Cumbica-Guarulhos-SP, Brasil
Tel: 011-6465-6810
Fax: 011-6465-6829

Related Documents: V_R10000, V_R12000 User's Manual (U10278E)
V_R5000, V_R10000 User's Manual - Instruction (U12754E)

The related documents referred to in this publication may include preliminary versions. However, preliminary versions are not marked as such.

V_R4000, V_R4200, V_R4400, V_R5000, V_R10000, V_R12000, and V_R series are trademarks of NEC Corporation.

MIPS and ANDES are trademarks of MIPS Technologies, Inc.

UNIX is a registered trademark licensed by X/Open Company Limited in the US and other countries.

Windows NT is either a registered trademark or a trademark of Microsoft Corporation in the United States and/or other countries.

The export of this product from Japan is prohibited without governmental license. To export or re-export this product from a country other than Japan may also be prohibited without a license from that country. Please call an NEC sales representative.

This product employs technology which is restricted by the export control regulations of the United States of America. Permission of the United States government might be required in case of exporting this product or products in which this product is installed.

No part of this document may be copied or reproduced in any form or by any means without the prior written consent of NEC Corporation. NEC Corporation assumes no responsibility for any errors which may appear in this document.

NEC Corporation does not assume any liability for infringement of patents, copyrights or other intellectual property rights of third parties by or arising from use of a device described herein or any other liability arising from use of such device. No license, either express, implied or otherwise, is granted under any patents, copyrights or other intellectual property rights of NEC Corporation or others.

While NEC Corporation has been making continuous effort to enhance the reliability of its semiconductor devices, the possibility of defects cannot be eliminated entirely. To minimize risks of damage or injury to persons or property arising from a defect in an NEC semiconductor device, customers must incorporate sufficient safety measures in its design, such as redundancy, fire-containment, and anti-failure features.

NEC devices are classified into the following three quality grades:

"Standard", "Special", and "Specific". The Specific quality grade applies only to devices developed based on a customer designated "quality assurance program" for a specific application. The recommended applications of a device depend on its quality grade, as indicated below. Customers must check the quality grade of each device before using it in a particular application.

Standard: Computers, office equipment, communications equipment, test and measurement equipment, audio and visual equipment, home electronic appliances, machine tools, personal electronic equipment and industrial robots

Special: Transportation equipment (automobiles, trains, ships, etc.), traffic control systems, anti-disaster systems, anti-crime systems, safety equipment and medical equipment (not specifically designed for life support)

Specific: Aircrafts, aerospace equipment, submersible repeaters, nuclear reactor control systems, life support systems or medical equipment for life support, etc.

The quality grade of NEC devices is "Standard" unless otherwise specified in NEC's Data Sheets or Data Books. If customers intend to use NEC devices for applications other than those specified for Standard quality grade, they should contact an NEC sales representative in advance.

Anti-radioactive design is not implemented in this product.