

TA7248P

DC MOTOR DRIVER

The TA7248P is a DC motor (3 phase) driver IC.

It contains regulator, position sensing amplifiers, control amplifier, quick stop circuit and drivers. Maximum output current (Bi-direction) of driver is $\pm 900\text{mA}$ (average).

Hall element is used as a position sensor.

By combining this IC and TA7674P (or TA7715P) F-servo motor driver system is available.

FEATURES:

- . Driver for Hall Motor (3 phase)
- . Large Output Current (Bi-direction)
 - : $I_O = \pm 900\text{mA}$ (average)
- . Built-in Reverse Rotation Detector and Quick Stop Circuit.
- . Regulator for External Circuits
 - : $V_{OUT} = 10.7\text{V}$, $I_O = 50\text{mA}$
- . Operating Supply Voltage : $V_{CC} = 16 \sim 32\text{V}$

Unit in mm

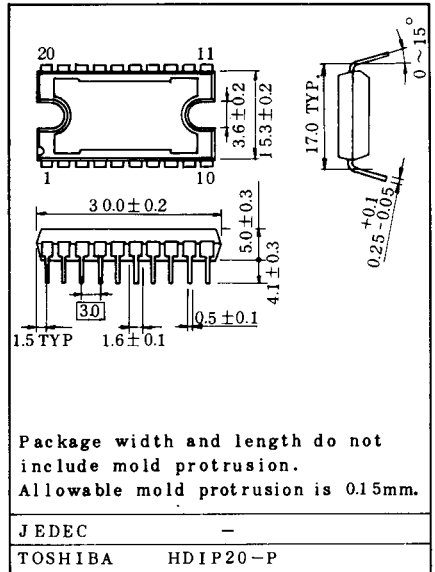

MAXIMUM RATINGS ($T_a = 25^\circ\text{C}$)

CHARACTERISTIC	SYMBOL	RATING	UNIT
Supply Voltage	V_{CC}	35	V
Output Current	I_O	900	mA
Regulator Output Current	I_{CC2}	50	mA
Power Dissipation (Note)	P_D	25	W
Operating Temperature	T_{opr}	$-15 \sim 75$	$^\circ\text{C}$
Storage Temperature	T_{stg}	$-55 \sim 150$	$^\circ\text{C}$

Note : $T_c = 75^\circ\text{C}$, $P_D = 3\text{W}(\text{Max.})$ at no heat sink ($T_a = 25^\circ\text{C}$).

TA7248P

BLOCK DIAGRAM

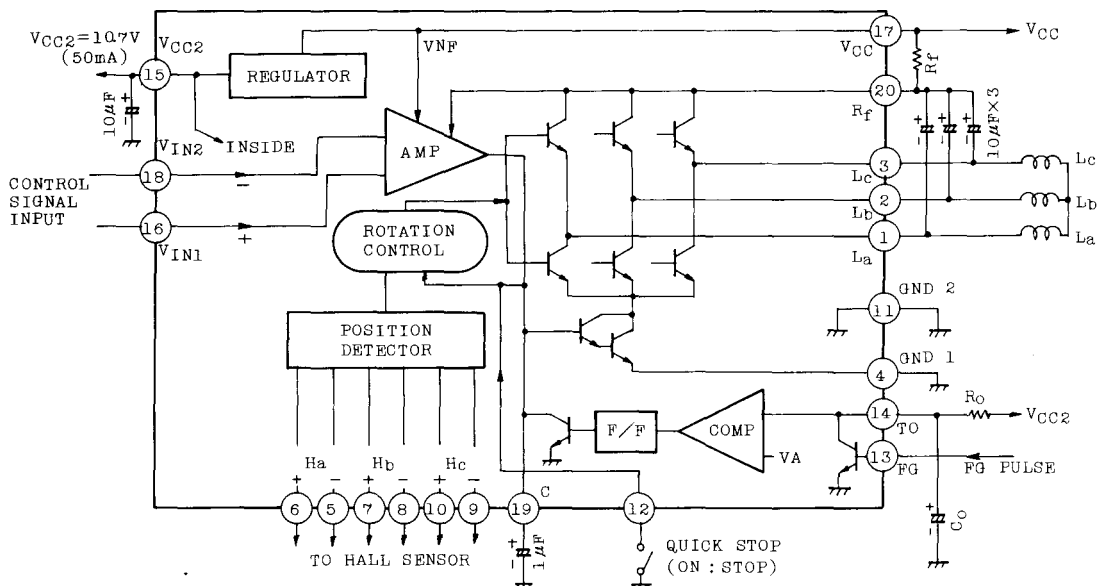

ELECTRICAL CHARACTERISTICS

(Unless otherwise specified, $V_{CC}=30V$, $R_L=27\Omega$, $R_f=2.2\Omega$, $T_a=25^\circ C$)

CHARACTERISTIC	SYMBOL	TEST CIRCUIT	TEST CONDITION	MIN.	TYP.	MAX.	UNIT
Supply Current	I_{CC}	1	-	5.5	-	13	mA
Input Offset Voltage	V_{IO}	2	$V_{IN2}=3.5V$	-9	-	95	mV
Input Dead Band	V_{ID}	2		22	-	190	mV
Residual Output Voltage	V_{OR}	2		-	-	10	mV
Voltage Gain	G_V	2		0.8	-	1.2	
Saturation Voltage	Upper	V_{SAT1}	$V_{IN1}=4.5V$, $V_{IN2}=3.5V$	-	-	2.1	V
	Lower	V_{SAT2}		-	-	3.8	
Cut-off Current	Upper	I_{OC1}	$V_{IN1}=4.5V$, $V_{IN2}=3.5V$ $R_L=100k\Omega$	-	-	15	μA
	Lower	I_{OC2}		-	-	15	
To Threshold Voltage	V_{T0}	5	-	6.2	-	7.3	V
To Saturation Voltage	$V_{SAT TO}$	5	$R_L=6k\Omega$	-	-	2	V
Output Voltage	V_{CC2}	6	$R_L=560\Omega$	10.2	10.7	11.2	V
Load Regulation Voltage	ΔV_{CC2}	6	$R_L=560\Omega \sim \infty$	-	-	60	mV
Ripple Rejection	RR	6	$R_L=560\Omega$, $f=1kHz$	50	-	-	dB
Temperature Coefficient	$T_c V_{CC2}$	6	$R_L=560\Omega$	-2	-	2	mV/deg

INPUT OUTPUT CHARACTERISTICS

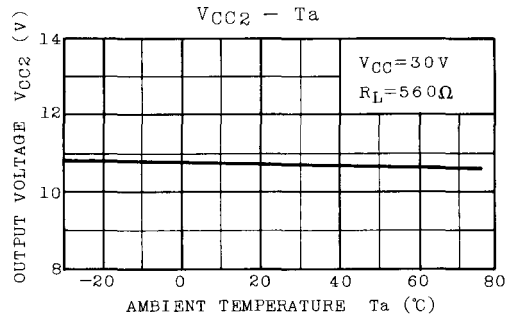
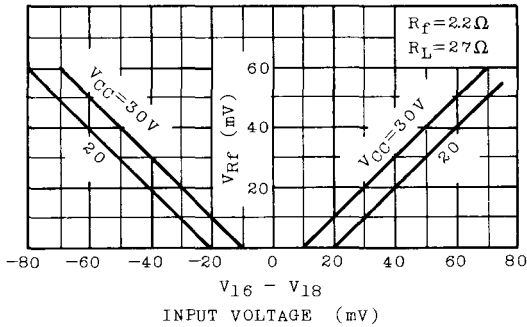

RR - f

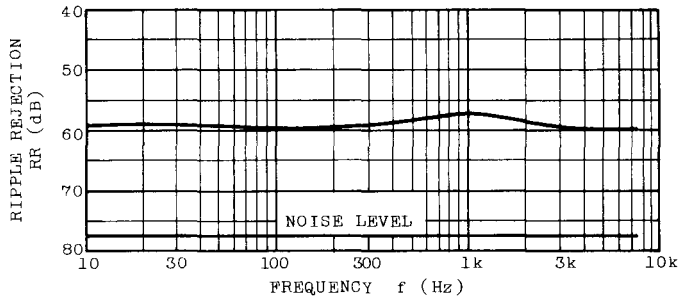

Z_o - f

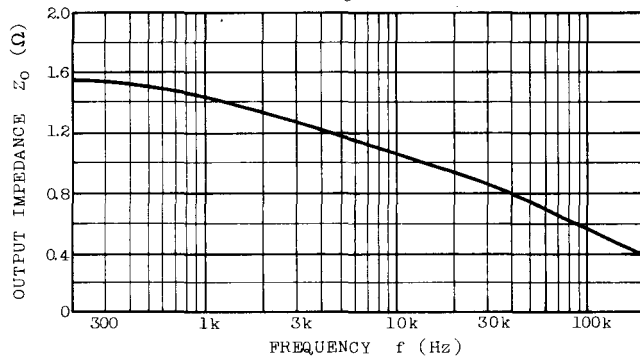

APPLICATION CIRCUIT

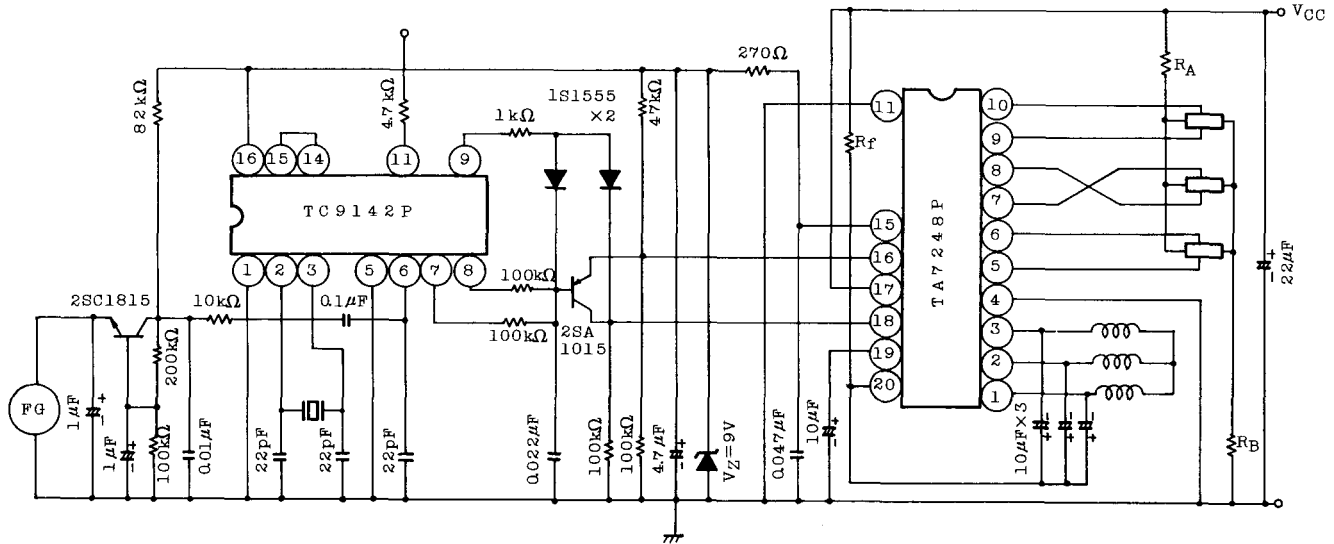

R_A and R_B should be determined by characteristic of hall sensor.