

**CONTROL DATA
165·165-2
P L O T T E R**

**CONTROL DATA
165-165-2
P L O T T E R**

CONTENTS

Chapter 1 - Principles of Operation		
Data and Control Lines		2
Function Codes		4
Write Operations		6
Read Operations		8
Logical Analysis		8
Select Circuit		8
Write Circuit		9
Read Circuit		10
Chapter 2 - Maintenance		
Logic Circuits		11
Delay Circuits		12
Power Circuits		13
Appendix		
A	Equation File and Card Placement Diagram	A-1

FIGURES

Chapter 1 - Principles of Operation		
1-1	Data and Control Lines	2
1-2	Plotter Coordinates	6
1-3	Plotter Control Panel	6
1-4	Timing Diagram	7
1-5	Write Operation Flow Chart	10
Chapter 2 - Maintenance		
2-1	165 Control Unit, Interior View	11
2-2	Delay Circuits	12
2-3a	Transpac Power Circuits	13
2-3b	Sola Power Circuits	14
2-4	Read and Select Circuits	15
2-5	Write Circuit	16
2-6	Fuses and Cable Connections	17
2-7	Transformer Connectors	17

TABLES

1-1	External Function and Output Instructions	4
1-2	Plotter Controls and Function	7

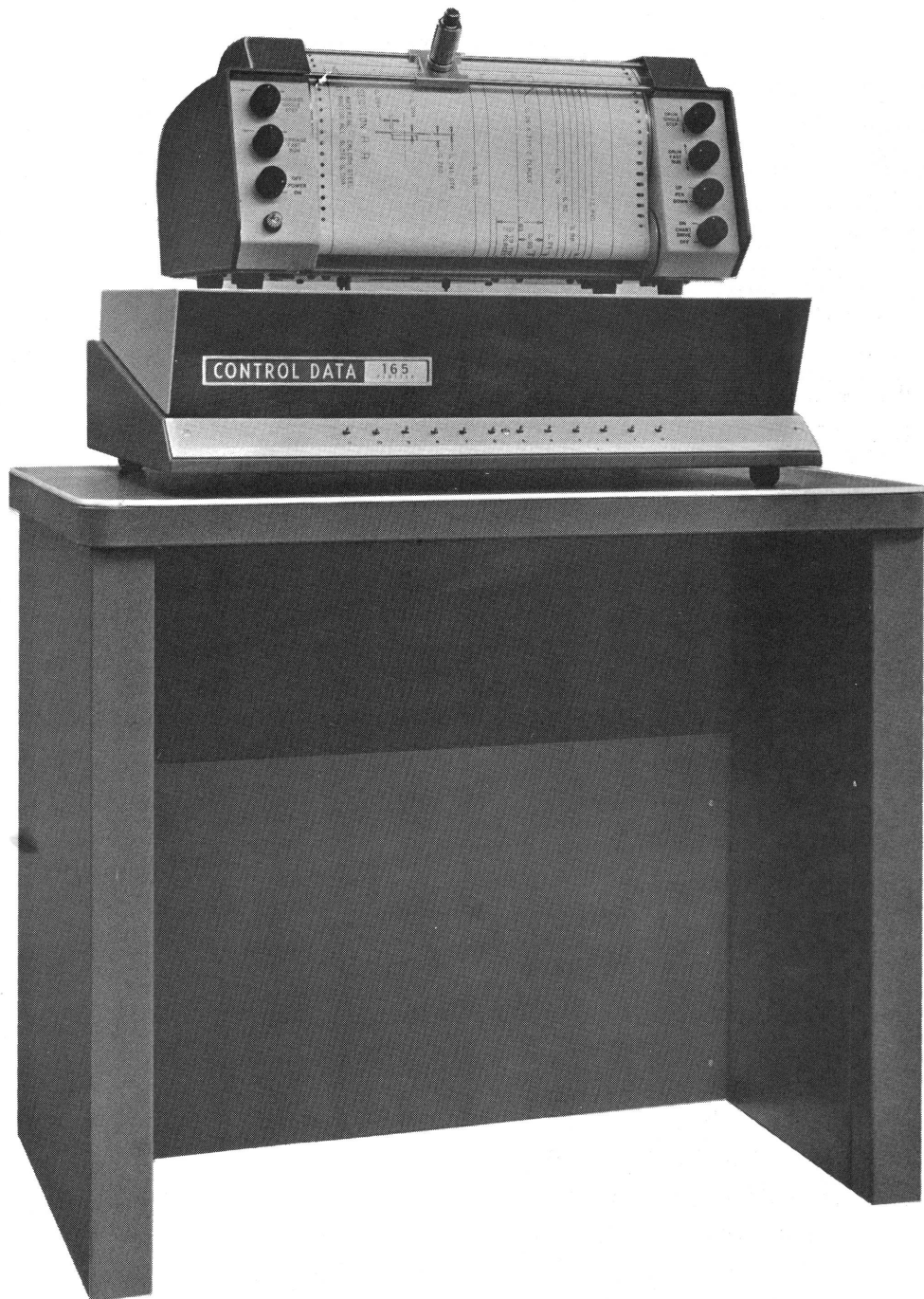

CHAPTER ONE

PRINCIPLES OF OPERATION

The Control Data Corporation 165 and 165-2 Plotters are optional input/output devices for the 160 computer system. The 165 consists of a CCP 560 Digital Recorder and a control unit that permits direct (on-line) communication between the 160 computer and the 560 digital recorder. The 165-2 consists of a CCP 565 Digital Recorder and a control unit that permits direct (on-line) communication between the 160 computer and the 565 digital recorder.

The 560 and 565 digital recorders (plotters) are high-speed two-axis recorders for plotting one variable against another. The plotters consist of a ballpoint pen mounted on a carriage and a bi-directional recording drum. A paper feed and take-up mechanism handles paper rolls 12 inches wide by 100 feet long. Drum sprocket teeth engage paper sprocket holes to drive the paper past the recording pen. The 560 operates at 200 steps per second; the 565, at 300 steps per second.

The plotter and the control unit form a compact unit 17 inches high, 18 inches wide, and 14 inches long. The computer provides 60 cycle power to the plotter and the control unit. Basic connections between computer, control unit, and plotter are shown in figure 1-1.

Output words from the computer direct pen carriage movement and drum rotation as well as movement of the pen against or away from the recording surface. (Additional information concerning the plotter may be found in the 560 or 565 Digital Recorder Instruction Manuals accompanying the unit.)

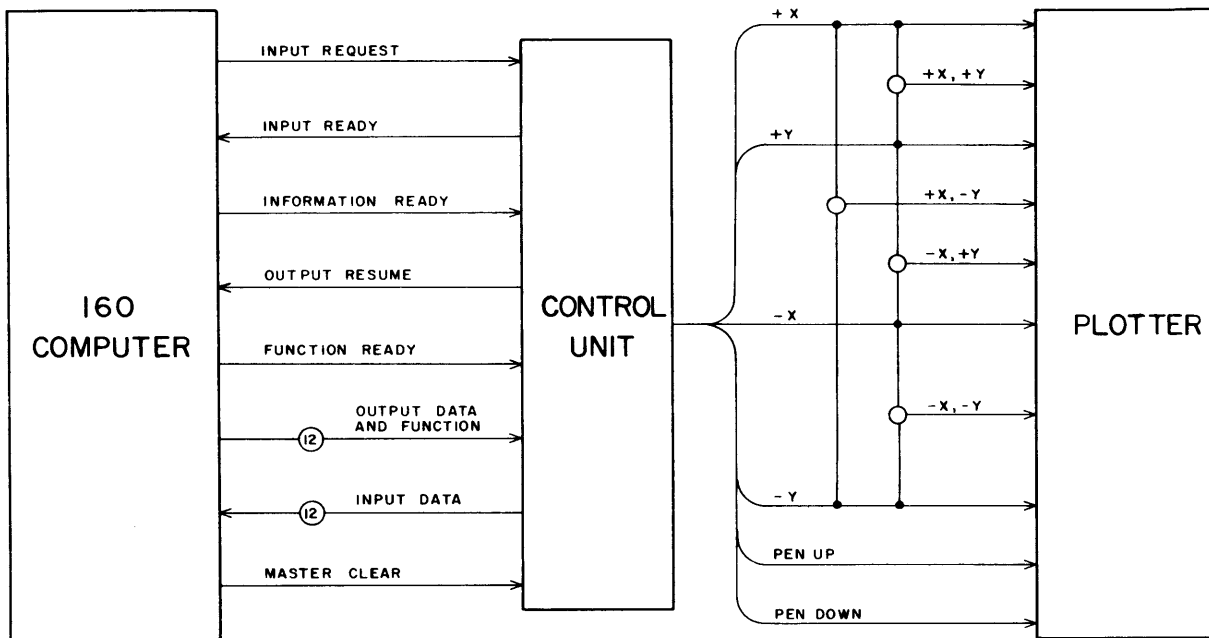

Figure 1-1. Data and Control Lines

DATA AND CONTROL LINES

The control unit is connected to the computer by an input/output cable which contains 12 input and 12 output lines and all control lines.

Output lines carry either a 12-bit function code or 12 data bits from the computer to the control unit; input lines carry 12 bits of information from the control unit to the computer. Information transmitted is accompanied by a signal: information ready for output data transfer, function ready for a function code, and input ready for input data transfer.

Electrical Characteristics

Wires per cable	24 twisted pairs (one wire of each pair connected to ground at each end of cable). One pair for ground, 23 pairs for information.
-----------------	---

Data signals	-16 v (binary "1") -0.5 v (binary "0")
Rise and fall time	2 usec (minimum) to 4 usec (maximum)
Current required	10 ma (maximum)
Line capacity	0 to 0.002 uf
Cable ground return d-c resistance	1/2 ohm (maximum)
Signal stabilization time	2 usec (minimum from time data signal appears until ready signal is generated)

Signals from Computer to Control Unit

Signal	Description
DATA Lines (12)	
Output Data	As DATA lines, they carry the 12-bit output words.
Output Function	As FUNCTION lines, they carry the EXF code which selects the control unit and its operation (read or write).
Function Ready	Produced when EXF code is present on output data lines. Initiated by instruction 75; causes equipment to examine EXF code. Removed by output resume signal.
Input Request	Indicates computer is ready for input information. Drops on receipt of input ready signal. Computer operation stops until input ready is received.
External Master Clear	Clears external equipments attached to computer. Establishes initial operating conditions within control unit. Appears when Load/Clear computer console switch is DOWN.
Input Data (12 lines)	Carry the 12-bit input word requested by computer.
Output Resume	Indicates control unit has accepted EXF code or output word. Turns off ready signals at computer which in turn drops output resume.
Input Ready	Indicates control unit contains information for computer to sample. Turned off when computer drops input request signal.

FUNCTION CODES

All plotter operations controlled by the computer are initiated by coded EXF instructions (table 1-1, figure 1-2). The upper 6 bits of the 12-bit code select the plotter control unit; the lower 6 bits specify mode of operation (read or write). In output mode, output instructions which follow the EXF code direct plotter operation in graphing the relationship between any two variables. The 0001 code, for example, moves the pen carriage in the +X direction while the drum remains stationary. The 0004 code, on the other hand, moves the drum past the stationary carriage and pen in the -Y direction to produce a line in the +Y direction. Codes that involve both carriage and drum movement (X and Y) produce a line at a 45° angle to the X axis.

TABLE 1-1. EXTERNAL FUNCTION AND OUTPUT INSTRUCTIONS

Computer Code	Instruction	Execution Time
4401	External Function 1) Selects Plotter 2) Selects Write Operation	< 20 usec
4440	External Function 1) Selects Plotter 2) Selects Read Operation	< 20 usec
0001	Output (+X) 1) Carriage and pen move 0.01" in +X direction 2) Next output word accepted in 5 ms	(74 inst.) ≤ 20 usec (73 inst.) > 20 usec
0002	Output (-X) 1) Carriage and pen move 0.01" in -X direction 2) Next output word accepted in 5 ms	(74 inst.) ≤ 20 usec (73 inst.) > 20 usec
0004	Output (+Y) 1) Drum rotates 0.01" in -Y direction 2) Next output word accepted in 5 ms	(74 inst.) ≤ 20 usec (73 inst.) > 20 usec

TABLE 1-1. (Cont'd)

Computer Code	Instruction	Execution Time
0005	Output (+X, +Y) 1) Carriage and pen move 0.01" in +X direction, Drum rotates in -Y direction 2) Next output word accepted in 5 ms	(74 inst.) \leq 20 usec (73 inst.) $>$ 20 usec
0006	Output (-X, +Y) 1) Carriage and pen move 0.01" in -X direction, Drum moves 0.01" in -Y direction 2) Next output word accepted in 5 ms	(74 inst.) \leq 20 usec (73 inst.) $>$ 20 usec
0010	Output (-Y) 1) Drum moves in +Y direction 2) Next output word accepted in 5 ms	(74 inst.) \leq 20 usec (73 inst.) $>$ 20 usec
0011	Output (+X, -Y) 1) Carriage and pen move 0.01" in +X direction, Drum moves 0.01" in +Y direction 2) Next output word accepted in 5 ms	(74 inst.) \leq 20 usec (73 inst.) $>$ 20 usec
0012	Output (-X, -Y) 1) Carriage and pen move 0.01" in -X direction, Drum moves 0.01" in +Y direction 2) Next instruction accepted in 5 ms	(74 inst.) \leq 20 usec (73 inst.) $>$ 20 usec
0020	Output 1) Moves pen down to paper 2) Next instruction accepted in 60 ms	(74 inst.) \leq 20 usec (73 inst.) $>$ 20 usec
0040	Output 1) Moves pen away from paper 2) Next instruction accepted in 60 ms	(74 inst.) \leq 20 usec (73 inst.) $>$ 20 usec

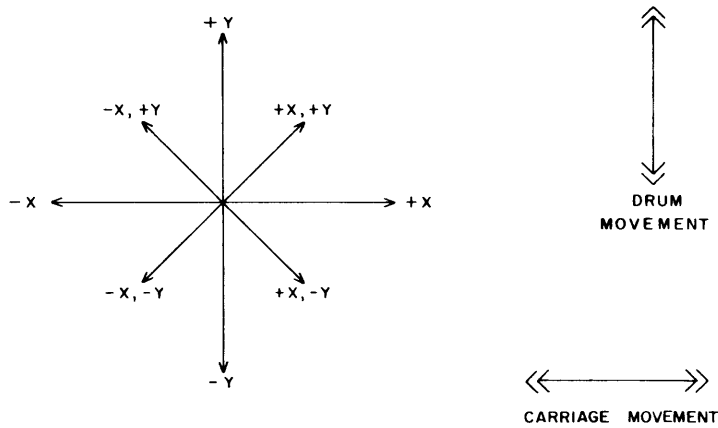

Figure 1-2. Plotter Coordinates

WRITE OPERATIONS

During write operation, plotter controls (figure 1-3, table 1-2) must be positioned as follows: carriage single step selected, drum single step selected, and chart drive motor switch on.

Output instructions for moving the recording pen down to or over the recording surface must follow the EXF write code (4401).

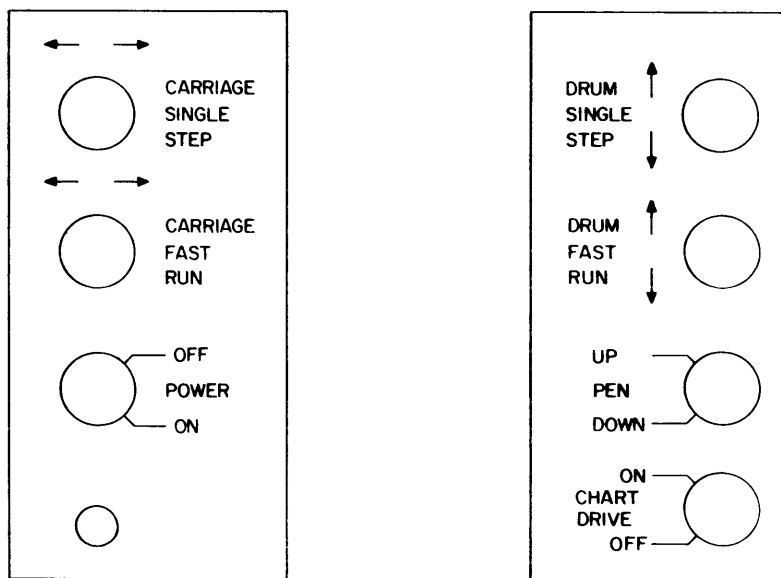

Figure 1-3. Plotter Control Panel

TABLE 1-2. PLOTTER CONTROLS AND FUNCTION

Controls	Function
Power Switch	Turns unit on or off if power is not supplied by computer
Carriage Single Step	Moves pen in +X or -X direction 0.01 in. (one step)
Carriage Fast Run	Moves pen in +X or -X direction at rate of 120 steps/sec.
Drum Single Step	Moves paper in +Y or -Y direction one step
Drum Fast Run	Moves paper in +Y or -Y direction at rate of 120 steps/sec.
Pen Up Pen Down	Raises or lowers recording pen
Chart Drive Motor Switch	Controls paper take-up and feed mechanism

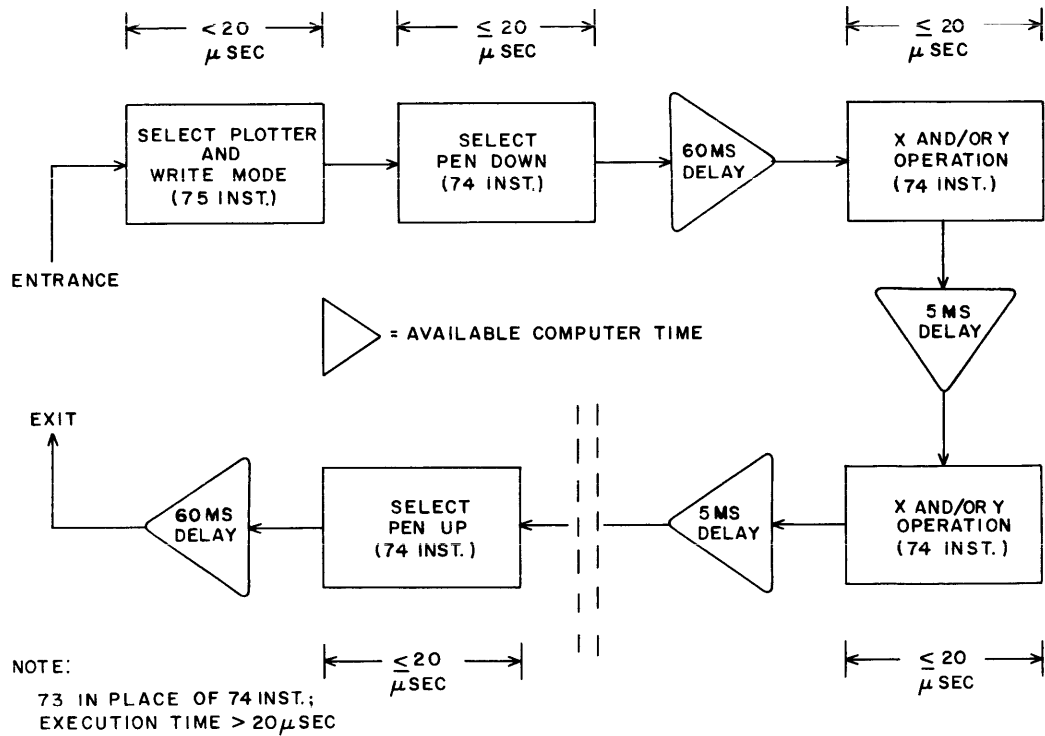

Figure 1-4. Timing Diagram

The control unit will accept sequential X and/or Y output instructions at a maximum rate of 200 steps per second, or 300 steps per second in 165-2 (5 ms intervals). Pen up or pen down instructions will be accepted at 60 ms intervals. Since the plotter remains selected until master cleared or until a different external equipment is selected, it need not be reselected after every output instruction.

READ OPERATIONS

A 4440 EXF instruction selects read mode of operation and senses the status of 12 manual switches on the plotter. These switches may be selected at any time and may be used in any manner deemed applicable by the operator. If, for example, the program calls for a 4401 EXF instruction followed by a 7600 (input A) instruction, input information is placed in the A register. Status of the switches as reflected by the A register can then be used to determine the next operation.

LOGICAL ANALYSIS

This discussion of the logical aspects of the circuits which comprise the control unit is based on the logic diagram, figure 2-4.

SELECT CIRCUIT

The select circuit interprets the EXF code to determine whether the plotter is selected and, if so, which mode of operation is required, read or write.

To select the plotter, a function ready signal must be present and the upper 6 bits of the EXF code must be translated as 44. Outputs from M111 and M108 must be "1's".

Assume first that a function ready signal is present. The "1" output from A103 is delayed by Y100 for 1.5 usec before being applied as an input to A104. During the delay, the resulting "1" output from A104 clears both Select Read and Select Write FF's. If the plotter is not selected, Read and Write FF's will remain cleared. If the plotter is selected, the "1" from A103 performs two functions: it allows an output resume to be sent to the computer which drops the function

ready signal, and it partially enables set inputs to both Read and Write FFs. Output of M100 (bit 0) determines which FF will be set. If the bit is a "1" (EXF code = 4401) Write FF is set, if bit 5 is a "1" (EXF code = 4440) Read FF is set.

WRITE CIRCUIT

The write circuit controls the transfer rate of output information from computer to plotter (figure 1-5).

After Select Write FF is set, the plotter stops until an information ready signal is received from the computer. The resulting "1" outputs from A106 and A107 first allow transfer of information from computer to plotter by enabling the AND inputs to L100 through L106. Second, they set Select Pen FF (B104/105) if the pen has been selected up or down. Third, they allow an output resume (via L106) to be produced approximately 6 usec after the information ready signal is first received by the control unit. During the 6 usec delay, information on the lines is stabilized and transferred to the plotter.

Disabling the input to A105 sets B100/101. (A106 produces a "1" for 1.5 usec because Y101 delays output of A105.) Setting this FF allows B102/103 to be set via the 2 ms or 55 ms delay path; the state of Select Pen FF determines the path. For example, if the FF is set indicating the last plotter operation involved the pen, B108 produces the necessary "1" output and 55 ms later B102/103 is set and B100/101 is cleared. Regardless of the circuit chosen, however, B102/103 will be set at the end of the delay.

During the time B100/101 is set, B110/B111 disables the input to A105 and inhibits any attempt to transfer additional information to the plotter. In the clear state, B110/B111 enables the AND input to A105 after a delay of 3 ms (1.3 ms delay in 165-2) and allows transfer of input information when an information ready signal occurs. Between successive write selections the circuit stabilizes during the 3 ms delay.

The time between setting and clearing B100/101 governs the rate at which the control unit accepts and transfers computer output information. This period is equal to the selected delay path (55 ms or 2 ms) plus 3 ms (or 1.3 ms in 165-2).

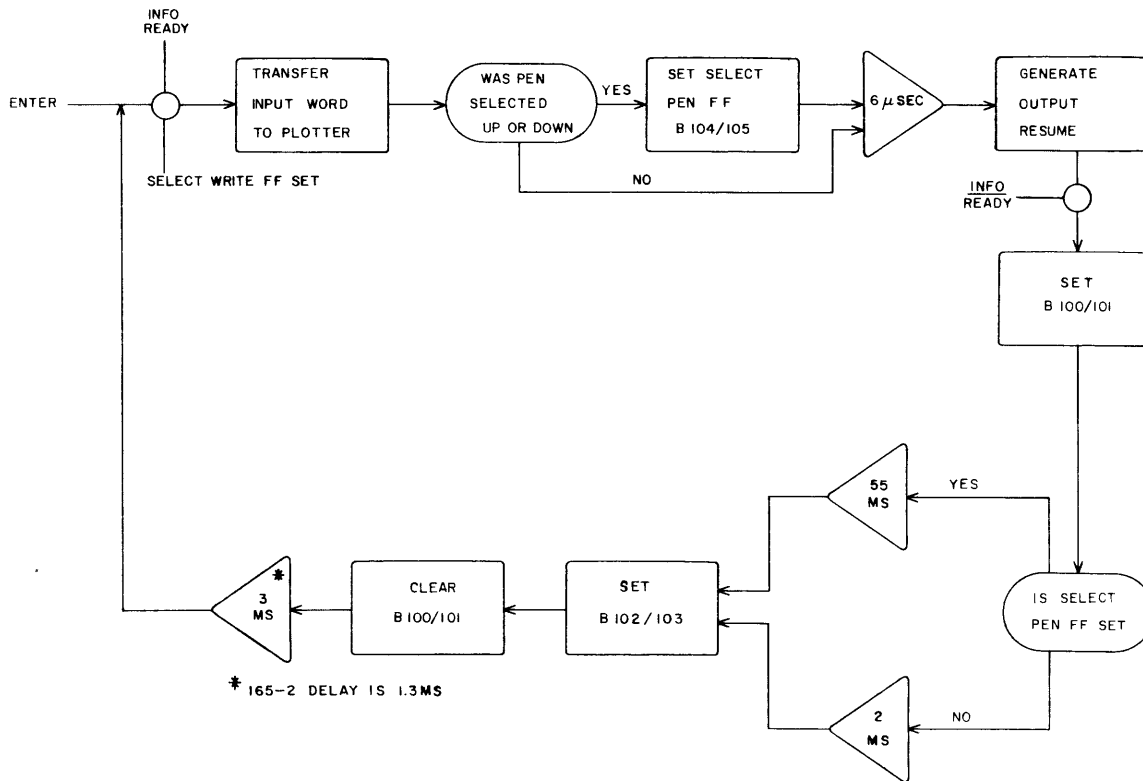

Figure 1-5. Write Operation Flow Chart

READ CIRCUIT

When an input request signal is received, the circuit returns an input ready signal and simultaneously enables input gates to L200 through L211. The 12-bit word sent to the computer reflects the state of 11 manual switches located on the control unit. If a switch is toggled, ground is applied as an input to the M--- card, and the bit will be sensed as a "1".

CHAPTER TWO MAINTENANCE

LOGIC CIRCUITS

Circuits of the 165 plotter are contained on standard Control Data printed circuit cards mounted in 30-pin connectors on the chassis frame (figure 2-1). All electrical connections between the control unit, the 160 computer and the plotter are made with standard conversion cards. Schematic diagrams for cards in the adapter showing all components, d-c voltages and terminal pins may be found in the Card Tester Instruction Manual.

Output conversion L card type 62	converts low-level voltages (-0.5 and -3v) within the computer to high-level voltages (0v and -20v) for transmission between units
Input conversion M card type 61	converts high-level voltages from cables to low-level voltages used by control unit

These conversion cards have no logical properties.

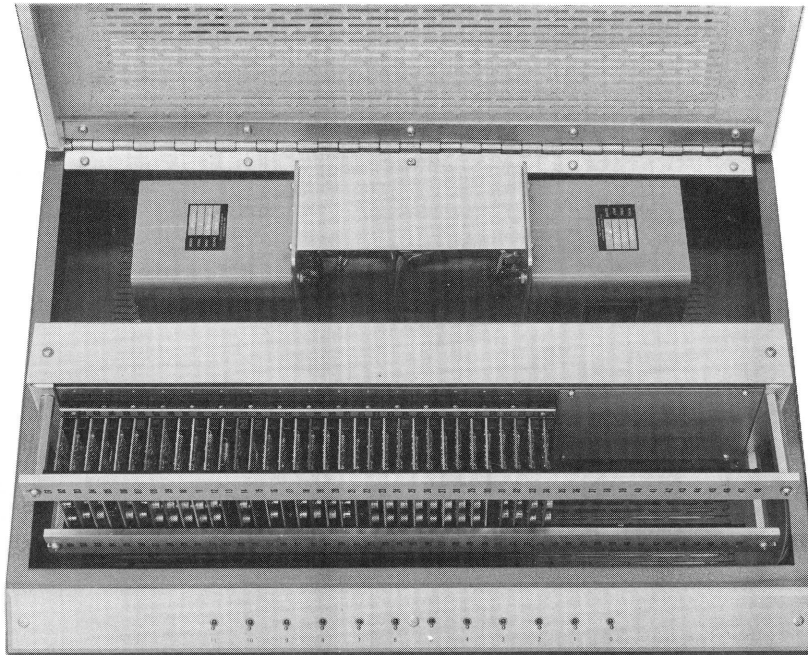

Figure 2-1. 165 Control Unit, Interior View

DELAY CIRCUITS

Signal delays are accomplished by connecting an integrating circuit to the junction of a pair of logic cards (figure 2-2). The integrating circuit delays negative going voltage changes for a period approximately equal to the time constant (RC) of the circuit.

Short delays are provided by the circuit shown in figure 2-2a; the capacitor mounted on a type 73 card is connected to the junction of an output diode of card A and an input diode of card B. The input resistor of card B and the capacitor form an RC circuit. The delay period is approximately equal to the product of R and C.

Longer delay periods are provided by the circuit shown in figure 2-2b. L and M cards result in a greater voltage variation across the integrating circuit and thus in longer delay periods.

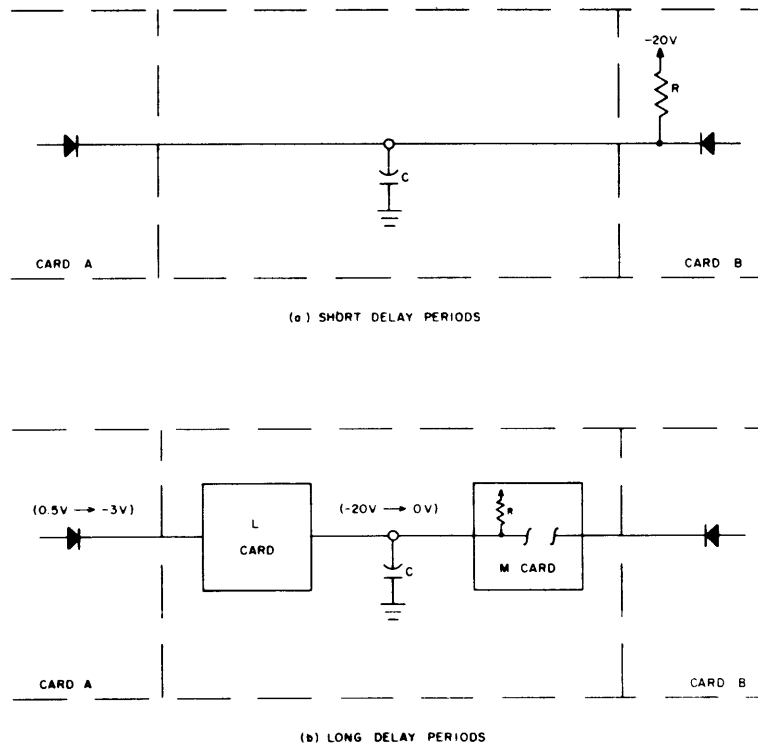

Figure 2-2. Delay Circuits

POWER CIRCUITS

The control unit receives 120 vac, 60 cps, single phase power from the 60-cycle switch panel within the 160 computer installation.

Primary Power

Power cables from the junction box terminate at connection J04 (figure 2-3). This connector provides power to the plotter. In addition, 60 cps power is applied to pin 2 of the power supply.

DC Power

Two tubeless Transpac power supplies (figure 2-3a), or in some models, one Sola power supply (figure 2-3b), fully rectify and filter the 115v input level and provide +20 and -20 d-c voltage to the printed circuit cards. Within the chassis, the -20v level is applied to pin 13 of all the cards, chassis ground to pin 14 and +20v to pin 15.

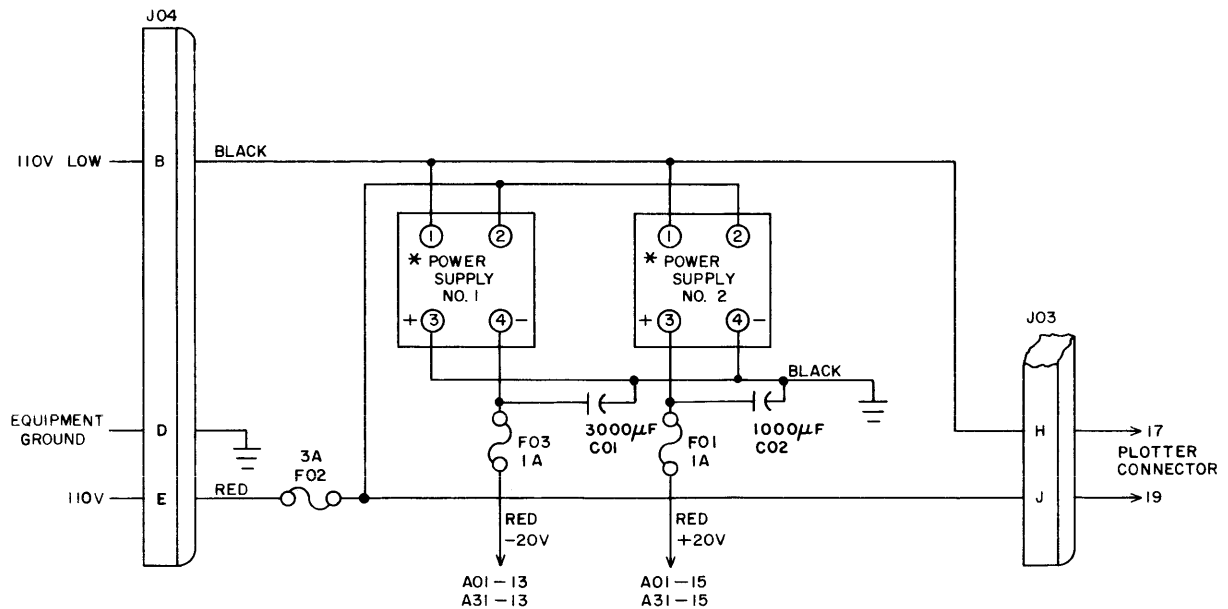
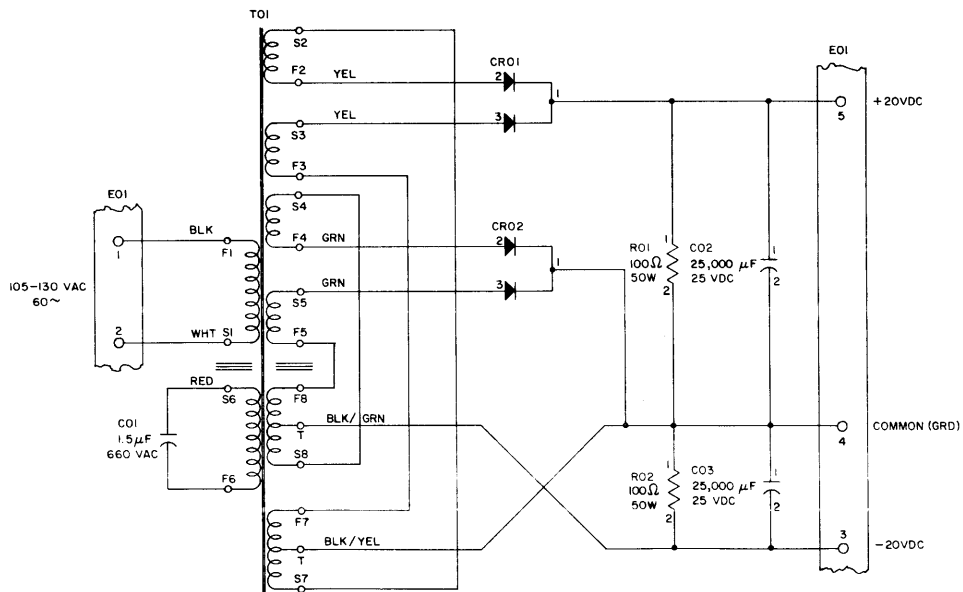
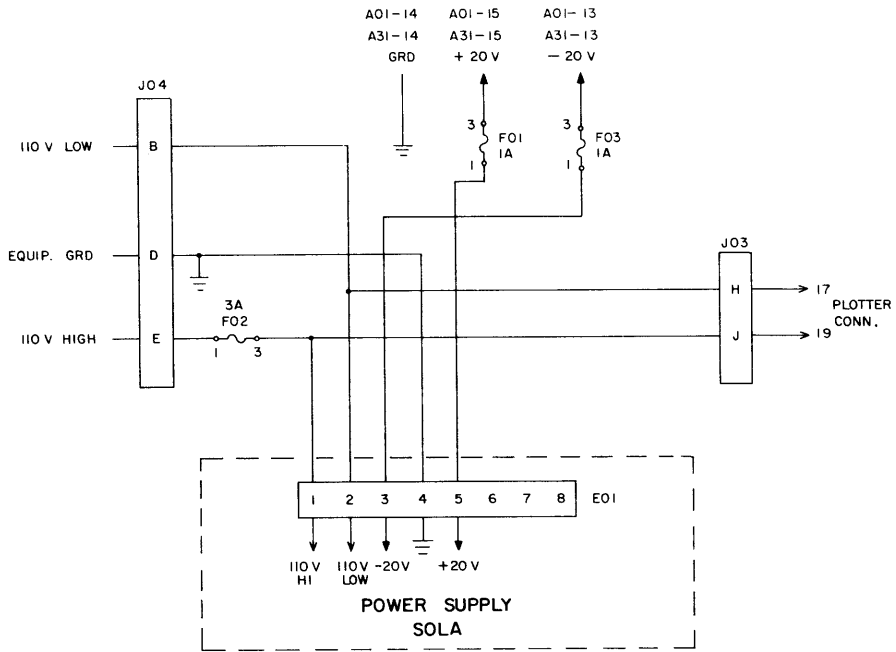

Figure 2-3a. Transpac Power Circuits



SYMBOL	DESCRIPTION	VALUE	CONTROL DATA NO.
C01	Capacitor, transformer	1.5 mfd 660 vac	631
C02, 03	Capacitor, electrolytic	25,000 mfd 25 vdc	629
CR01	Rectifier, GE Series 4JA411 Mod. AC1AH1		628
CR02	Rectifier, GE Series 4JA411 Mod. AC1AH2		644
R01, 02	Resistor, Wirewound, Adjustable	100 ohm, 50 w	630
T01	Transformer, Constant Voltage	Sola #9-1833	632

Figure 2-3b. Sola Power Circuits

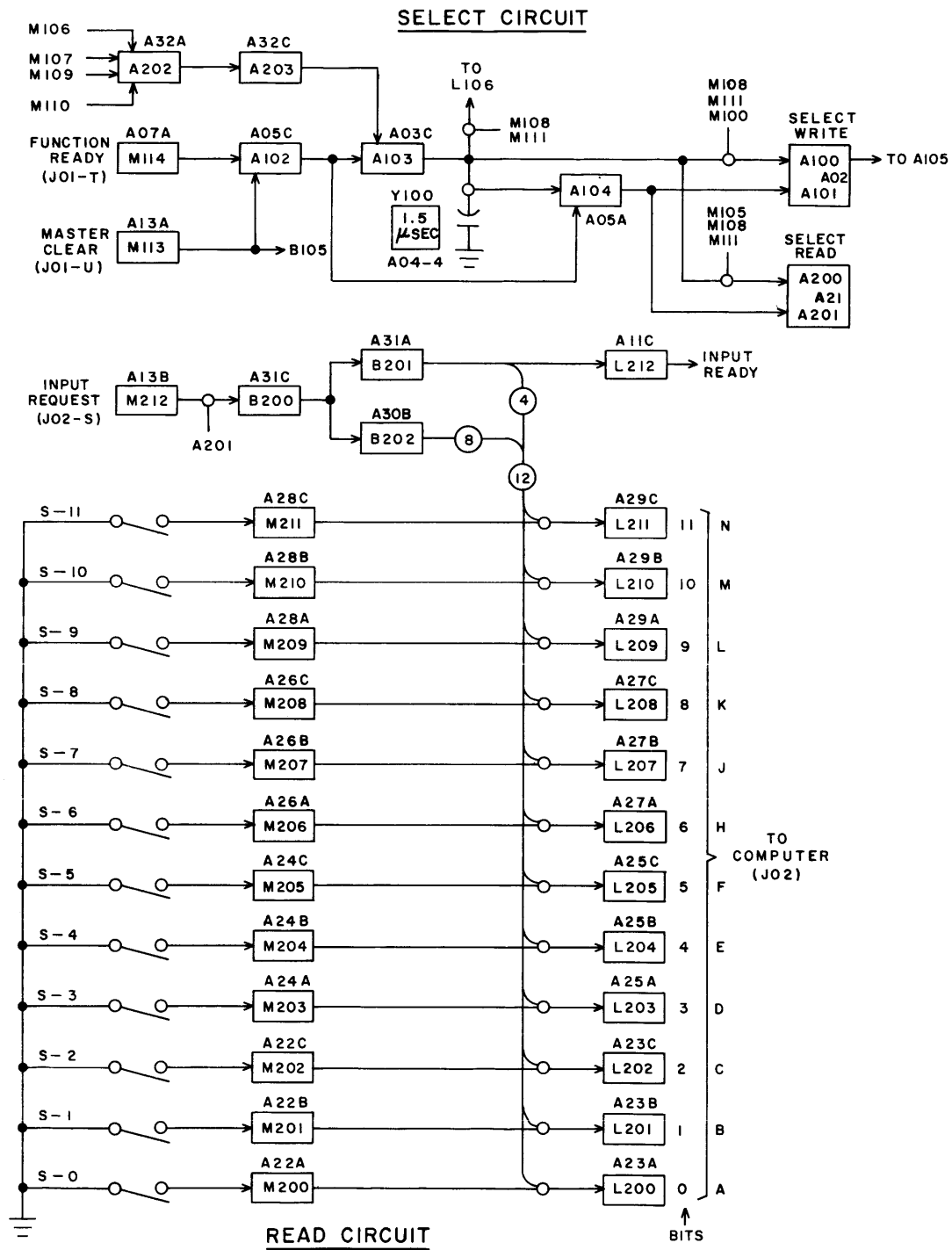

Figure 2-4. Read and Select Circuits

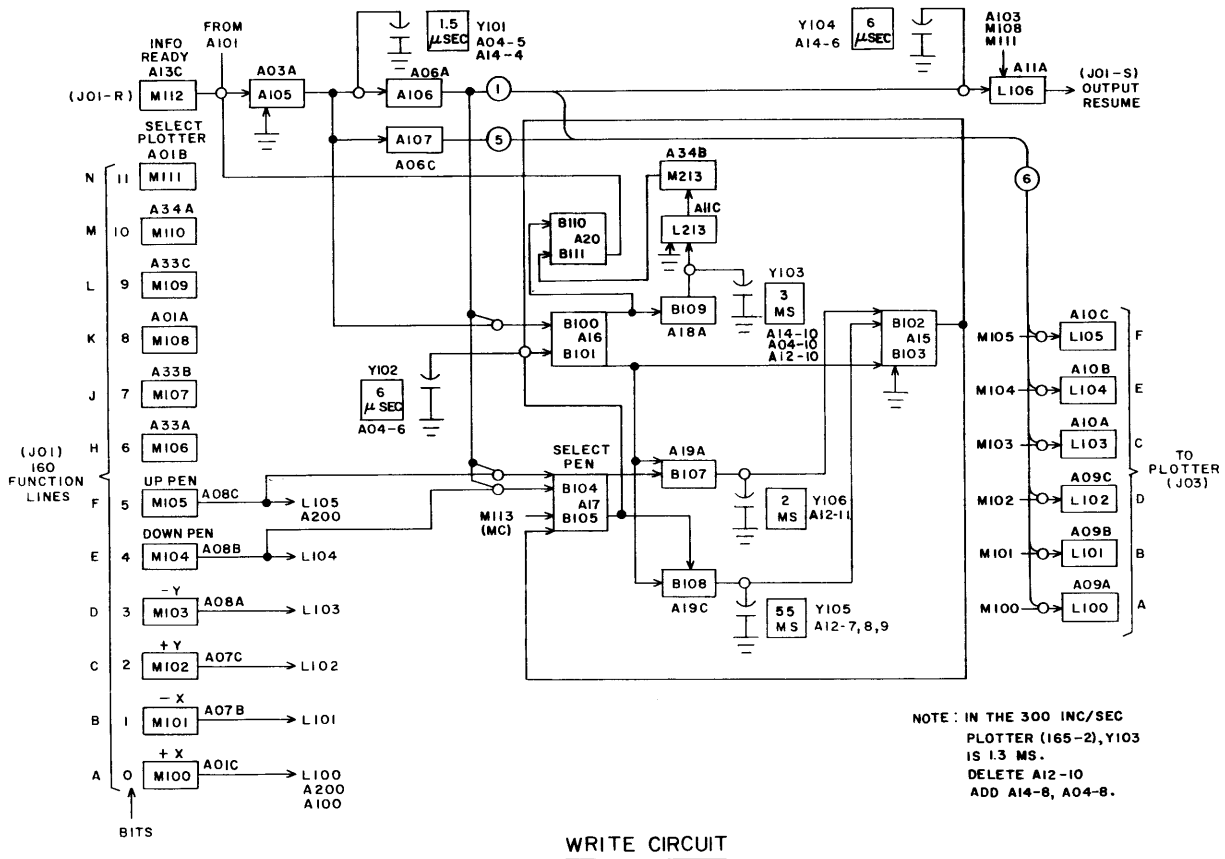

Figure 2-5. Write Circuit

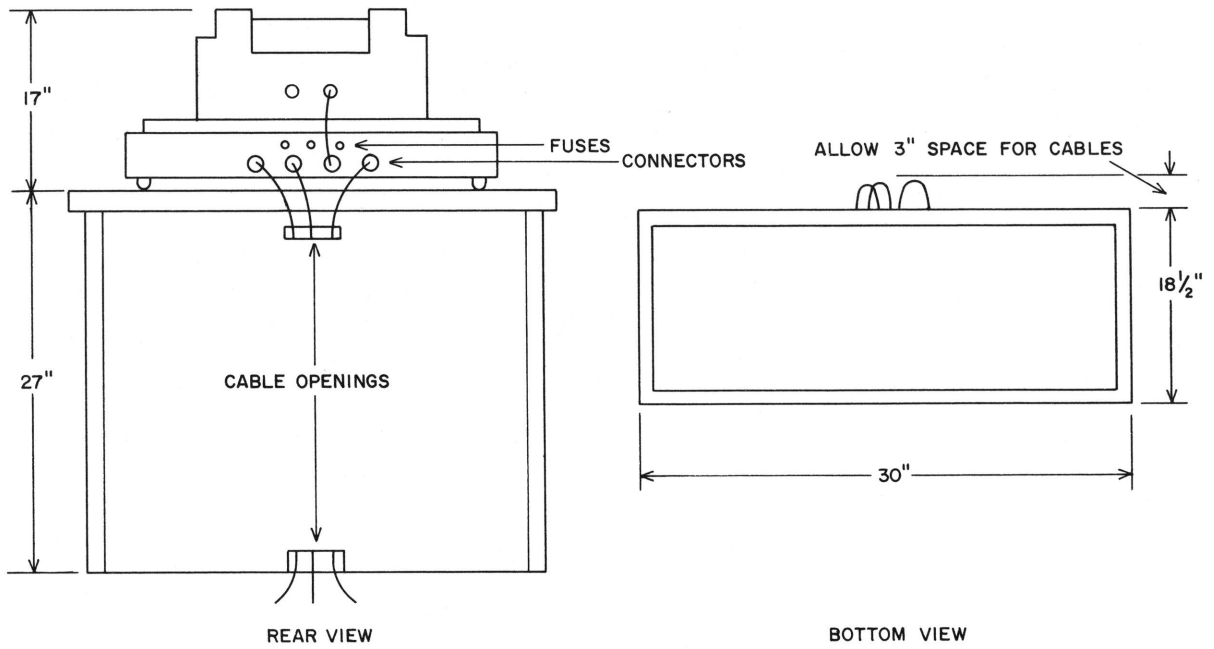

Figure 2-6. Fuses and Cable Connections

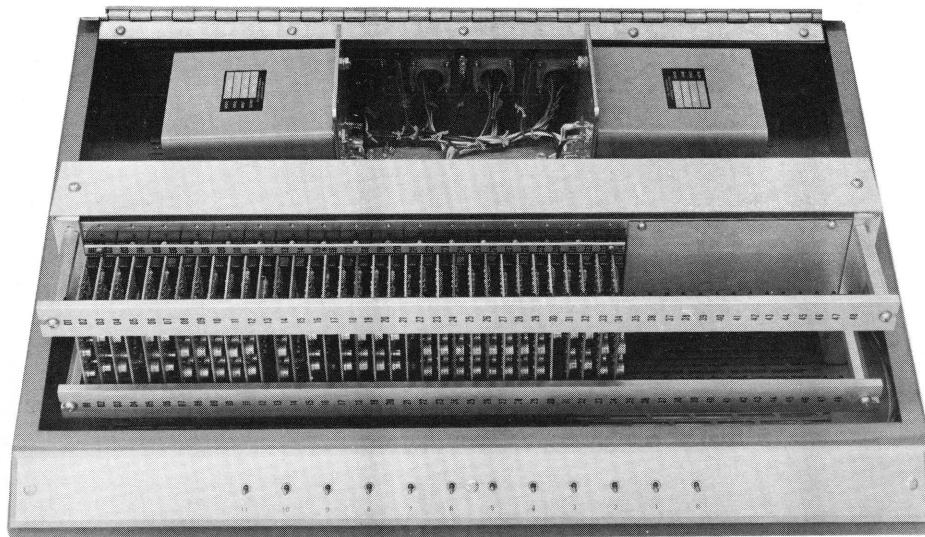

Figure 2-7. Transformer Connection

APPENDIX A

EQUATION FILE AND
CARD PLACEMENT DIAGRAM

LOCATION	01	02	03	04	05	06	07	08	09	10	11	12	13	14	15	16
A	M108	A100	A105	VARIABLE DELAY	A104	A106	M114	M103	L100	L103	L106	DELAY	M113	VARIABLE DELAY	B102	
	M111	A101	A103		A103	A107	M101	M104	L101	L104	L212		M212		B103	
	M100						M102	M105	L102	L105	L213		M112			
CARD TYPE	87	31	22	73	22	21	61	87	62	62	67	77	61	73	32	

A-2

15	16	17	18	19	20	21	22	23	24	25	26	27	28	29	30	31	32	33	34
	B100	B104	B109	B107	B110	A200	M200	L200	M203	L203	M206	L206	M209	L209	B202	B201	A202	M106	M110
	B101	B105		B108	B111	A201	M201	L201	M204	L204	M207	L207	M210	L210		B200	A203	M107	M213
							M202	L202	M205	L205	M208	L208	M211	L211				M109	
	31	32	21	22	31	31	61	62	61	62	61	62	61	62	11	21	24	61	61

CARD PLACEMENT

$$A^{100} = A^{101} + A^{103} M^{100} M^{111} M^{108}$$

$$A02A : A^{101}$$

$$A^{101} = A^{100} + A^{104}$$

$$A02C : A^{100} : A^{105}$$

$$A^{102} = M^{114} + M^{113}$$

$$A05C : A^{103} : A^{104}$$

$$A^{103} = A^{102} + A^{203}$$

$$A03C : A^{100} : A^{200} : A^{104} : L^{108}$$

$$A^{104} = A^{102} + A^{103} Y^{100}$$

$$A05A : A^{201} : A^{101}$$

$$A^{105} = M^{112} A^{101} B^{110} + \text{GND}$$

$$A03A : A^{106} : A^{107} : B^{100}$$

$$A^{106} = A^{105} Y^{101}$$

$$A06A : B^{100} : B^{104} : B^{104} : L^{105} : L^{106}$$

$$A^{107} = A^{105}$$

$$A06C : L^{100} : L^{101} : L^{102} : L^{103} : L^{104}$$

$$A^{200} = A^{201} + A^{103} M^{105} M^{108} M^{111}$$

$$A21A : A^{201}$$

$$A^{201} = A^{200} + A^{104}$$

$$A21C : A^{200} : B^{200}$$

$$A^{202} = M^{106} + M^{107} + M^{108} + M^{110}$$

$$A32A : A^{203}$$

$$A^{203} = A^{202}$$

$$A32C : A^{103}$$

$$B^{100} = B^{101} + A^{105} A^{106}$$

$$A16A : B^{101} : B^{107} : B^{108} : B$$

$$B^{101} = B^{100} + B^{103} B^{104} Y^{102}$$

$$A16C : B^{100} : B^{109} : B^{110}$$

$$B^{102} = B^{103} + B^{107} Y^{108} + B^{108} Y^1$$

$$A15A : B^{103}$$

$$B^{103} = B^{102} + B^{100} + Y^{888}$$

$$A15C : B^{102} : B^{101} : B^{105}$$

$$B^{104} = B^{105} + M^{105} A^{106} + M^{104} A^1$$

$$A17A : B^{105} : B^{108} : B^{101}$$

$$B^{105} = B^{104} + B^{103} + M^{113}$$

$$A17C : B^{104} : B^{107}$$

$$B^{107} = B^{100} + B^{105}$$

$$A19A : B^{102}$$

$$B^{108} = B^{100} + B^{104}$$

$$A19C : B^{102}$$

$$B^{109} = B^{101}$$

$$A18A : L^{213}$$

$$B^{110} = B^{111} + B^{101}$$

$$A20A : B^{111} : A^{105}$$

$$B^{111} = B^{110} + M^{213}$$

$$A20C : B^{110}$$

$$B^{200} = M^{212} A^{201}$$

$$A31C : B^{201} : B^{202}$$

$$B^{201} = B^{200}$$

$$A31A : L^{208} : L^{209} : L^{210} : L^{211} : L^{212}$$

$$B^{202} = B^{200}$$

$$A30B : L^{200} : L^{201} : L^{202} : L^{203} : L^{204} : L^{205} : L^{206} : L^{207}$$

$$L^{100} = M^{100} A^{107}$$

$$A09A : J^{03}-A$$

$$L^{101} = M^{101} A^{107}$$

$$A09B : J^{03}-B$$

$$L^{102} = M^{102} A^{107}$$

$$A09C : J^{03}-D$$

$$L^{103} = M^{103} A^{107}$$

$$A10A : J^{03}-C$$

$$L^{104} = M^{104} A^{107}$$

$$A10B : J^{03}-E$$

$$L^{105} = M^{105} A^{106}$$

$$A10C : J^{03}-F$$

$$L^{106} = A^{106} Y^{104} + A^{103} M^{108} M^{111}$$

$$A11A : J^{01}-S$$

$$L^{200} = M^{200} B^{202}$$

$$A23A : J^{02}-A$$

$$L^{201} = M^{201} B^{202}$$

$$A23B : J^{02}-B$$

$$L^{202} = M^{202} B^{202}$$

$$A23C : J^{02}-C$$

$$L^{203} = M^{203} B^{202}$$

$$A25A : J^{02}-D$$

$$L^{204} = M^{204} B^{202}$$

$$A25B : J^{02}-E$$

$$L^{205} = M^{205} B^{202}$$

$$A25C : J^{02}-F$$

$$L^{206} = M^{206} B^{202}$$

$$A27A : J^{02-H}$$

$$L^{207} = M^{207} B^{202}$$

$$A27B : J^{02-J}$$

$$L^{208} = M^{208} B^{201}$$

$$A27C : J^{02-K}$$

$$L^{209} = M^{209} B^{201}$$

$$A29A : J^{02-L}$$

$$L^{210} = M^{210} B^{201}$$

$$A29B : J^{02-M}$$

$$L^{211} = M^{211} B^{201}$$

$$A29C : J^{02-N}$$

$$L^{212} = B^{201} + Y^{999}$$

$$AllB : J^{02-R}$$

$$L^{213} = B^{109} Y^{103} + Y^{999}$$

$$AllC : M^{213}$$

$M^{100} = J^{01-A}$
 $A01C : A^{202} : A^{100} : L^{100}$
 $M^{101} = J^{01-B}$
 $A07B : L^{101}$
 $M^{102} = J^{01-C}$
 $A07C : L^{102}$
 $M^{103} = J^{01-D}$
 $A08A : L^{103}$
 $M^{104} = J^{01-E}$
 $A08B : B^{104} : L^{104}$
 $M^{105} = J^{01-F}$
 $A08C : B^{104} : L^{105} : A^{200}$
 $M^{106} = J^{01-H}$
 $A33A : A^{202}$
 $M^{107} = J^{01-J}$
 $A33B : A^{202}$
 $M^{108} = J^{01-K}$
 $A01A : L^{106} : A^{100} : A^{200}$
 $M^{109} = J^{01-L}$
 $A33C : A^{202}$
 $M^{110} = J^{01-M}$
 $A34A : A^{202}$
 $M^{111} = J^{01-N}$
 $A01B : L^{106} : A^{100} : A^{200}$
 $M^{112} = J^{01-R}$
 $A13C : A^{105}$
 $M^{113} = J^{01-U}$
 $A13A : A^{102} : B^{105}$

$M^{114} = J^{01-T}$
 A07A : A¹⁰²
 $M^{200} = S^{01}$
 A22A : L²⁰⁰
 $M^{201} = S^{02}$
 A22B : L²⁰¹
 $M^{202} = S^{03}$
 A22C : L²⁰²
 $M^{203} = S^{04}$
 A24A : L²⁰³
 $M^{204} = S^{05}$
 A24B : L²⁰⁴
 $M^{205} = S^{06}$
 A24C : L²⁰⁵
 $M^{206} = S^{07}$
 A26A : L²⁰⁶
 $M^{207} = S^{08}$
 A26B : L²⁰⁷
 $M^{208} = S^{09}$
 A26C : L²⁰⁸
 $M^{209} = S^{10}$
 A28A : L²⁰⁹
 $M^{210} = S^{11}$
 A28B : L²¹⁰
 $M^{211} = S^{12}$
 A28C : L²¹¹
 $M^{212} = J^{02-S}$
 A13B : B⁰⁰⁰
 $M^{213} = L^{213}$
 A11C : B¹¹¹

$\gamma^{100} = 1.5 \text{ us}$

A04-4 : A¹⁰⁴

$\gamma^{101} = 1.5 \text{ us}$

A04-5 : A14-4 : A¹⁰⁶

$\gamma^{102} = 6 \text{ us}$

A04-6

$\gamma^{103} = 3 \text{ ms}$

A04-10, A12-10, A14-10 : B¹¹⁰

$\gamma^{104} = 6 \text{ us}$

A14-6 : L¹⁰⁶

$\gamma^{105} \approx 55 \text{ ms}$

A12-7,8,9 : B¹⁰²

$\gamma^{106} = 2 \text{ ms}$

A14-11 : B¹⁰²

$\gamma^{999} = \text{GND}$

CONTROL DATA

CORPORATION

COMPUTER DIVISION

501 PARK AVENUE, MINNEAPOLIS 15, MINNESOTA