

CONTROL DATA[®] **DISK STORAGE UNIT**

BR2A5

**GENERAL DESCRIPTION
OPERATION
INSTALLATION AND
CHECKOUT
THEORY OF OPERATION
MAINTENANCE**

CONTROL DATA
CORPORATION

CUSTOMER ENGINEERING MANUAL

MANUAL STATUS CHECK SHEET

PUBLICATION NO. 70614600 Sheet 1 of 2 REVISION L
 PUBLICATION TITLE BR2A5 Disk Storage Unit Maintenance Manual

PAGE NUMBER	REV
Cover	-
Title Page	-
ii	L
iii	L
iv	L
v	A
vii	F
viii	K
ix	J
Section 1	-
1-1	A
1-2	A
1-3	J
Section 2	-
2-1	A
2-2	A
2-3	A
2-4	J
2-5	J
2-6	A
2-7	J
2-8	B
2-9	B
2-10	A
Section 3	-
3-1	F
3-2	B
3-3	J
3-4	A
3-5	A
3-6	J
3-7	B
3-8	B
3-9	B

PAGE NUMBER	REV
Section 4	-
4-1	A
4-2	A
4-3	A
4-4	A
4-5	A
4-6	A
4-7	A
4-8	A
4-9	A
4-10	A
4-11	A
4-12	B
4-13	B
4-14	A
4-15	A
4-16	A
4-17	A
4-18	A
4-19	A
4-20	A
4-21	A
4-22	B
4-23	K
4-24	K
4-25	B
4-26	K
4-27	A
4-28	B
4-29	A
4-30	B
4-31	A
4-32	A

PAGE NUMBER	REV
4-33	A
4-34	A
4-35	A
4-36	A
4-37	A
4-38	A
4-39	A
4-40	A
4-41	A
4-42	A
4-43	A
4-44	A
4-45	A
Section 5	-
Section 6	-
6-1	J
6-2	J
6-3	F
6-4	F
6-5	J
6-6	G
6-7	F
6-8	F
6-9	F
6-10	F
6-11	A
6-12	A
6-13	A
6-14	A
6-15	J
6-16	A
6-17	A
6-18	J

PAGE NUMBER	REV
6-19	J
6-20	J
6-21	J
6-22	J
6-23	J
6-24	K
6-25	H
6-26	A
6-27	H
6-28	A
6-29	J
6-30	J
6-31	J
6-32	J
6-33	D
6-34	J
6-35	A
6-36	A
6-37	J
6-38	A
6-39	J
6-40	A
6-41	B
6-42	J
6-43	J
6-44	J
6-45	A
6-46	A
6-47	A
6-48	K
6-48.1	K
6-49	J
6-50	L

PREFACE

Customer engineering material for the CONTROL DATA® BR2A5 Disk Storage Unit is contained in three separate manuals and provides all information needed to install, operate, and maintain the unit:

Publication No. 70614600	General Description, Operation, Installation and Checkout, Theory of Operation, Maintenance
Publication No. 70614700	Diagrams, Maintenance Aids, Wire Lists
Publication No. 70614800	Illustrated Parts List



CONTENTS

<p>1. GENERAL DESCRIPTION</p> <p>Introduction 1-1</p> <p>Equipment Specifications 1-2</p> <p>2. OPERATION</p> <p>Controls and Indicators 2-1</p> <p>Operating Instructions 2-8</p> <p style="padding-left: 20px;">DSU Power Application 2-8</p> <p style="padding-left: 20px;">Disk Pack Installation 2-9</p> <p style="padding-left: 20px;">Disk Pack Removal 2-10</p> <p>3. INSTALLATION AND CHECKOUT</p> <p>Uncrating 3-1</p> <p>Space Allocation 3-2</p> <p>Leveling and Aligning 3-2</p> <p>Cabling and Connections 3-2</p> <p style="padding-left: 20px;">Cabinet Intracabbling 3-2</p> <p style="padding-left: 20px;">Input/Output Cables 3-4</p> <p style="padding-left: 20px;">Power Cables 3-6</p> <p style="padding-left: 20px;">Ground Bond 3-6</p> <p>Cabinet Accessories 3-6</p> <p>Input Power Requirements 3-6</p> <p>Environment 3-7</p> <p>Initial Checkout and Startup Procedure 3-7</p> <p>4. THEORY OF OPERATION</p> <p>Functions 4-1</p> <p style="padding-left: 20px;">First Seek 4-12</p> <p style="padding-left: 20px;">Direct (Forward/Reverse) Seek 4-13</p> <p style="padding-left: 20px;">Return to Zero Seek (RTZS) 4-21</p> <p style="padding-left: 20px;">Read/Write/Erase 4-22</p>	<p>Assemblies 4-23</p> <p style="padding-left: 20px;">Power Supply 4-23</p> <p style="padding-left: 40px;">AC/DC Distribution 4-23</p> <p style="padding-left: 40px;">Power-On Sequence 4-25</p> <p style="padding-left: 40px;">Power-Off Sequence 4-27</p> <p style="padding-left: 20px;">Logic Chassis 4-28</p> <p style="padding-left: 20px;">Deck Assembly 4-29</p> <p style="padding-left: 40px;">Drive Motor Assembly 4-29</p> <p style="padding-left: 40px;">Hysteresis Brake Assembly 4-31</p> <p style="padding-left: 40px;">Spindle Assembly 4-31</p> <p style="padding-left: 40px;">Actuator 4-33</p> <p style="padding-left: 40px;">Transducers 4-39</p> <p style="padding-left: 40px;">Track Servo 4-40</p> <p style="padding-left: 40px;">Disk Cleaner Assembly 4-41</p> <p style="padding-left: 20px;">Blower System 4-44</p> <p>Disk Pack 4-45</p> <p>6. MAINTENANCE</p> <p>Maintenance Tools 6-1</p> <p>Maintenance Materials 6-2</p> <p>Preventive Maintenance 6-2</p> <p style="padding-left: 20px;">General 6-2</p> <p style="padding-left: 20px;">Preventive Maintenance Index 6-3</p> <p style="padding-left: 20px;">Inspect Actuator Assembly 6-3</p> <p style="padding-left: 20px;">Clean Front Cover Glass 6-3</p> <p style="padding-left: 20px;">Change Primary Filter 6-4</p> <p style="padding-left: 20px;">Check Power Supply Outputs 6-5</p> <p style="padding-left: 20px;">Inspect and Clean Read/Write and Servo Heads 6-6</p> <p style="padding-left: 20px;">Clean Shroud and Spindle 6-7</p> <p style="padding-left: 20px;">Clean Pack Cleaning Brushes 6-7</p> <p style="padding-left: 20px;">Clean and Lubricate Lockshaft 6-8</p> <p style="padding-left: 20px;">Replace Absolute Filter 6-8</p>
---	---

Corrective Maintenance	6-9	Index Sensor Assembly	6-34
CDC Pack Cleaning Procedure	6-9	Sensor Stop Check and Adjustment	6-34
Read/Write and Servo Heads	6-9	Index to Burst Check and Adjustment	6-35
Check Head/Arm Adjustment	6-10	Index Transducer Removal and Replacement	6-37
Head/Arm Removal Replacement	6-14	Transducer Output Check	6-38
Adjacent Track Erase Check	6-19	Shroud Adjustment	6-38
Tuned Amplifier Check and Adjustment	6-20	Disk Cleaner Assembly	6-39
Drive Belt Removal and Replacement	6-23	Check	6-39
Drive Motor Removal and Replacement	6-25	Adjustment	6-39
Drive Motor Pulley Removal And Replacement	6-27	Removal and Replacement	6-41
Hysteresis Brake or Felt Removal and Replacement	6-27	Head Select Preamplifier Card Removal and Replacement	6-41
Spindle Lock Pawl	6-29	Heads Loaded Switch	6-42
Check	6-29	Check	6-42
Adjustment	6-29	Removal and Replacement	6-43
Pack-On Switch	6-29	Velocity Transducer	6-43
Check and Adjustment	6-29	Check	6-43
Removal and Replacement	6-30	Removal and Replacement	6-44
Ground Spring Check and Adjustment	6-30	Carriage Alignment	6-46
Spindle and Lockshaft Assembly	6-31	DC Offset Check/Adjustment	6-47
Lockshaft Removal and Replacement	6-31	Track Servo Amplitude Adjustment	6-48.1
Spindle and Lockshaft Assembly Removal and Replacement	6-32	Power Amplifier Check/Adjustment	6-48.1
		Velocity Gain Check Adjustment	6-50
		Fine Position Gain Check/Adjustment	6-50
		Integrator Gain Check/Adjustment	6-53
		Servo/Filter Balance Check/Adjustment	6-55
		Troubleshooting	6-57
		Track Pulse Troubleshooting	6-57
		Access Troubleshooting	6-58

FIGURES

2-1	Controls and Indicators	2-7	6-4	Head Adjustment Trace	6-13
3-1	Cabinet Intracabling Diagram	3-3	6-5	Head/Arm Assembly Adjustment	6-15
3-2	System Intercabling	3-4	6-6	Head/Arm Replacement	6-16
4-1	Input/Output Signal Gating	4-2	6-7	Head/Arm Installation or Removal	6-17
4-2	Select Sequence	4-2	6-8	Symmetry Adjustment	6-20
4-3	Block Diagram	4-3	6-9	Read Oscillator Output Waveform	6-21
4-4	Servo Circuit Block Diagram	4-15	6-9.1	Symmetry Strobe Relation	6-22
4-5	Typical Servo Signal Relationships	4-16	6-10	Main Deck Underside	6-24
4-6	Fine Position Servo Signals	4-21	6-11	Motor and Brake Assembly	6-26
4-7	Power Supply - AC/DC Distribution	4-24	6-12	Index Sensor	6-33
4-8	Power Supply - Sequencing	4-26	6-13	Index to Burst Period	6-36
4-9	Deck Assembly	4-30	6-14	Detector Trace	6-37
4-10	Spindle Assembly	4-32	6-15	Index Transducer Trace	6-38
4-11	Actuator Assembly Elements	4-34	6-16	Disk Cleaner Adjustment	6-40
4-12	Head Loading	4-36	6-17	Read/Write Head Cable Connections	6-42
4-13	Head/Arm Assembly Motion	4-38	6-18	Velocity Transducer Replacement	6-45
4-14	Index/Sector Detection	4-40	6-19	Carriage Alignment	6-47
4-15	Velocity Detection	4-40	6-20	Power Amplifier Adjustment	6-49
4-16	Track Servo Detection	4-42	6-21	Velocity Gain Adjustment	6-51
4-17	Track and EOT Pulses	4-43	6-22	Fine Position Gain Adjustment	6-52
4-18	Blower System	4-44	6-23	Integrator Gain Adjustment	6-55
6-1	Cabinet Filters	6-4	6-24	Servo Filter Balance Adjustment	6-56
6-2	Pack Cleaning Brushes	6-8			
6-3	Head Identification	6-12			

TABLES

2-1	Controls and Indicators	2-1	4-2	Servo Circuit Functions	4-17
3-1	Input/Output Connector Pin Assignments	3-5	6-1	Read/Write Head Replacement Data	6-18
4-1	Input/Output Lines	4-4			

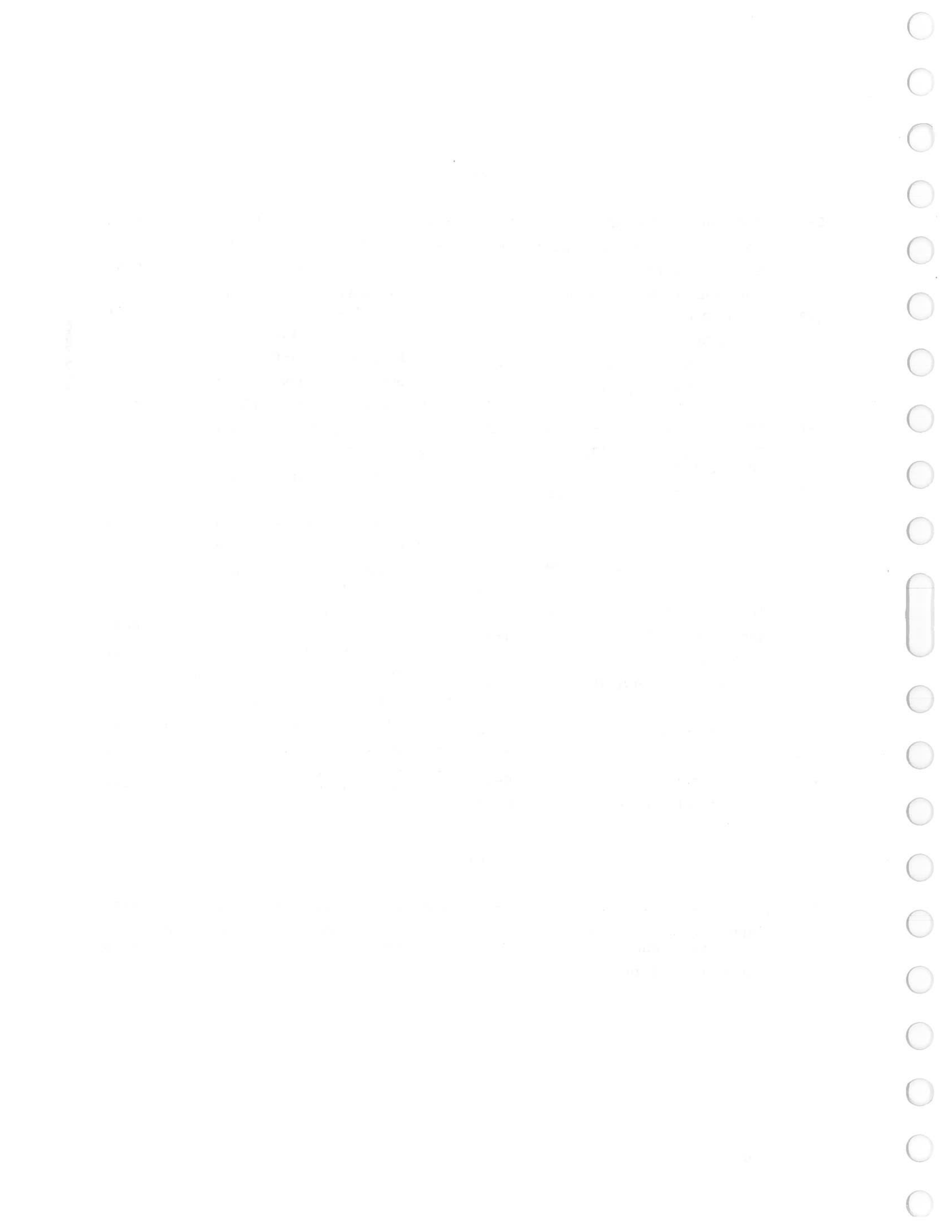

SECTION 1

GENERAL DESCRIPTION



GENERAL DESCRIPTION

INTRODUCTION

The CONTROL DATA[®] Disk Storage Unit is a high speed, random access, data storage device that interfaces with a central processor via a control unit.

The electro-mechanical Disk Storage Unit (DSU) positions its read/write heads to discrete positions or tracks over spinning disk surfaces. Data, in the form of magnetized bits or spots, is written on or read from the disk surfaces by the read/write heads.

The disk pack assemblies used by the DSU provide position feedback from specially recorded tracks on one surface of the disk pack.

The deck assembly contains the access mechanism that positions the read/write and track servo heads, as well as five Silicon Peripheral Logic (SPL) cards involved in track detection and Read/Write operations. This assembly also includes spindle assembly, spindle drive motor, and shroud, the mounting and operational facilities required by the disk pack. The shroud surrounds the disk pack and thereby minimizes the possibility of damage to the read/write heads and disk surfaces caused by ingestion of dust.

A hinge-mounted logic chassis assembly is the mounting point for the main complement of the logic cards used by the deck: five cards are mounted on the deck assembly. Cards for the cabinet are mounted in four rows (A through D). This assembly also contains a maintenance panel which provides jacks to monitor logic voltages, a switch/lamp combination to analyze the unit status and switches to control the DSU operational status.

A solid-state power supply assembly provides ± 5 , ± 20 , ± 36 , and $+40$ -vdc outputs.

A frame assembly provides the required mounting-structure for the previously mentioned assemblies. In addition to the structural elements, this assembly contains the operator controls for the deck and a blower assembly. The output of the blower assembly is ducted to the deck assembly to provide positive pressurization of the disk pack and shroud area. It also provides cooling air to the power supply and logic chassis.

EQUIPMENT SPECIFICATIONS

ACCESSING TIME

Maximum Access Time	70 ms
Maximum One-Track Access Time	10 ms
Average Access Time	35 ms

RECORDING

Mode	Double frequency
Density (nominal)	1530 bpi (outer track) 2220 bpi (inner track)
Bit Rate (nominal)	2.50 MHz
Data Transfer Rate	312,500 characters/second
Bits/Character	8
Character/Track	7,812
Tracks/Cylinder	19
Cylinders/DSU	400 + 6 spares
DSU/System	8 maximum

DATA CAPACITY

Bits/Track	62,500 nominal
Bits/Cylinder	1,187,500 nominal
Bits/DSU	475,000,000 nominal

DISK PACK

Disks/Disk Pack	11
Useable Recording Surfaces/Disk Pack	19
Disk Surface Diameter	14 inches
Recording Diameters	Track 405 (Inner) 8.760 inches nominal Track 0 (Outer) 13.200 inches nominal
Disk Surface Coating	Magnetic Oxide
Disk Pack Velocity	2400 ± 2% rpm

READ/ WRITE HEADS

Heads/Unit	19
Read/Write Track Width	0.004 inch nominal
Erase Track Width	0.0055 inch nominal
Track Spacing	0.00505 inch nominal
Read/Write to Erase Gap	0.045 inch nominal

PHYSICAL - EACH CABINET

Height	38 inches (96.52 cm)
Width	27 1/2 inches (69.85 cm)
Depth	37 1/2 inches (95.25 cm)
Weight	660 pounds (299.38 kg)

ELECTRICAL

Power Source	208 volt (±10%) BR2A5A 60 ±0.6 Hz, BR2A5B 50 ±0.5 Hz, three-phase (two legs used)
Operating Current	7 amps
Standby Current	3 amps
Surge Current	22 amps

INPUT/OUTPUT CONNECTIONS

One connector per cabinet located below logic chassis.
Pin assignment according to Table 3-1.
Connections according to Figure 3-2.

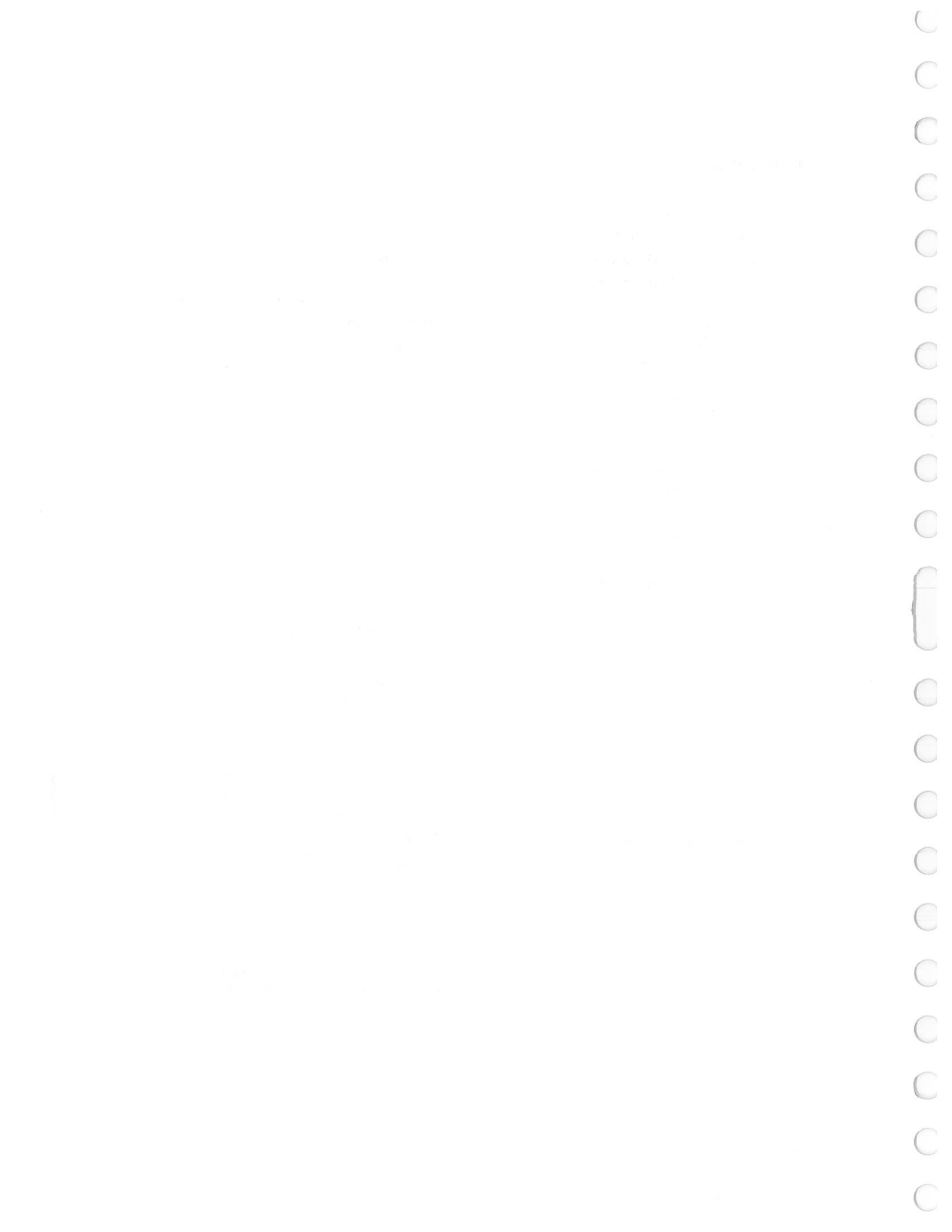

SECTION 2

OPERATION

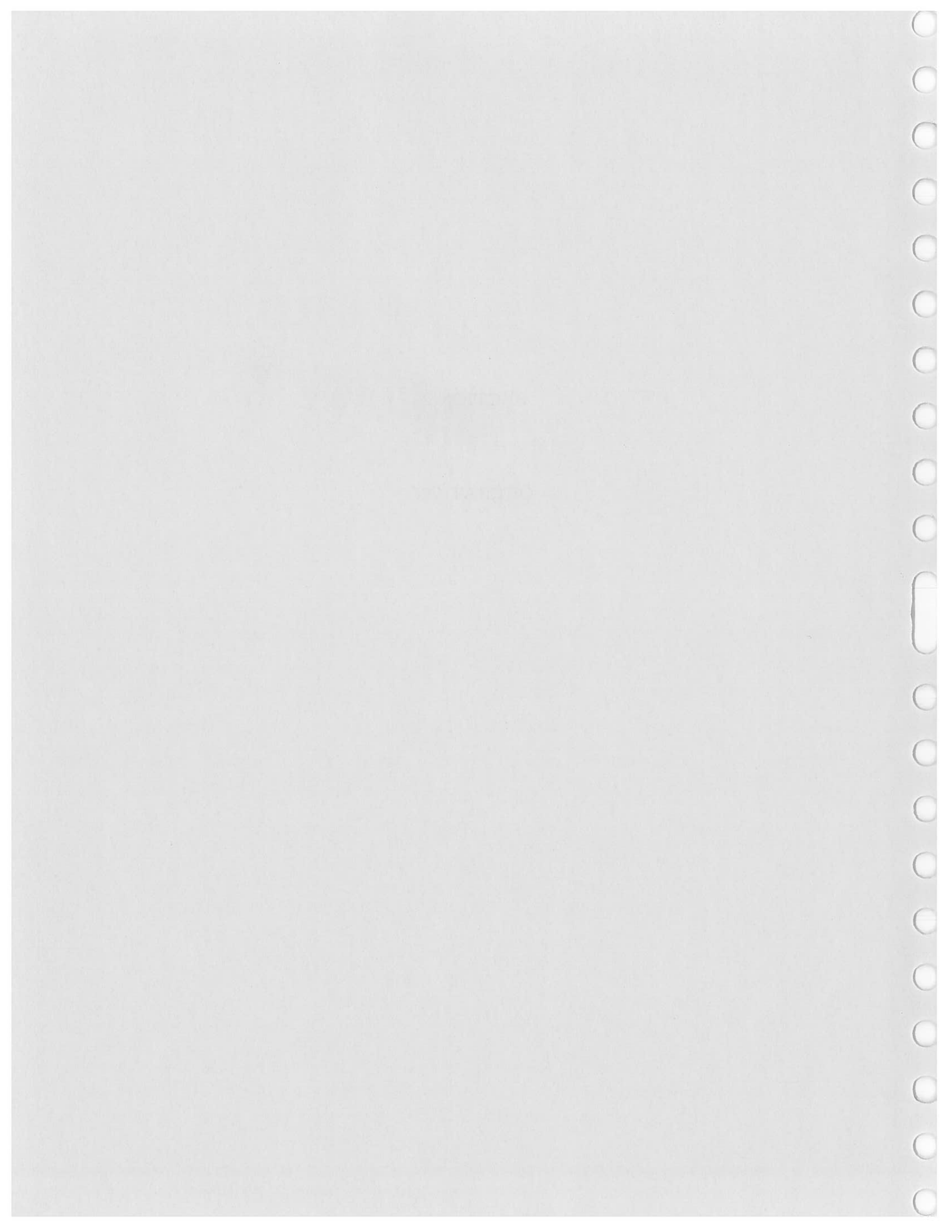

OPERATION

CONTROLS AND INDICATORS

The DSU contains a number of panels and indicators. Figure 2-1 locates the panels and the indicators on a typical cabinet of the DSU. A functional description of the controls and indicators is given in Table 2-1. Descriptions assume that AC power is applied to the unit by the controller.

TABLE 2-1. CONTROLS AND INDICATORS

Control Or Indicator	Function
Operator Panel	
START switch/indicator	<p>Switch energizes (when pressed to light) spindle drive motor and begins the First Seek sequence provided the following conditions are met:</p> <ol style="list-style-type: none">1. Disk pack is in place and cannister removed.2. Front and top covers are closed.3. Proper circuit breakers are on.4. DC switch is on. <p>Lights when switch is on even if one or more of the above conditions is not met. This allows operator to know which units will begin power-on sequence when the above conditions are met.</p> <p>Switch causes a power-off sequence when pressed with the indicator lighted.</p>

TABLE 2-1. CONTROLS AND INDICATORS (Cont'd)

Control Or Indicator	Function
<p>BEREIT (READY) indicator</p>	<p>BEREIT indicator lights when Operable signal is being sent from the DSU to the control unit. The following conditions must be met for the unit to originate an Operable signal:</p> <ol style="list-style-type: none"> 1. Heads loaded. 2. No fault conditions. 3. Up to speed (spindle rpm greater than 2200) 4. Logic Number plug installed. 5. Unit is on line. 6. COP signal from control unit is at -30 volts.
<p>WARTUNG (MAINTENANCE) indicator</p>	<p>WARTUNG indicator lights when either the logic chassis maintenance panel DC switch is set to OFF or the ON LINE/OFF LINE switch is set to OFF LINE.</p>
<p>SCHREIBEN GESPERRT (WRITE LOCKOUT) switch/indicator</p>	<p>Switch (when pressed to light) inhibits the ability of the related DSU to perform a write operation.</p> <p>Switch removes the inhibit condition when pressed with the indicator lighted.</p>
<p>FEHLER (FAULT) switch/indicator</p>	<p>Lights when one or more of the following unwanted conditions occur:</p> <ol style="list-style-type: none"> 1. More than one head is selected. 2. Read and Write Selects exist at the same time. 3. Read and Erase Selects exist at the same time. 4. Erase is selected with no write driver. 5. Erase is selected with both write drivers. 6. Either one or both write drivers are on with no erase. 7. Read, write, or erase is selected without an On Cylinder signal.

TABLE 2-1. CONTROLS AND INDICATORS (Cont'd)

Control Or Indicator	Function
<p>FEHLER (FAULT) (Cont'd)</p> <p>Logic Number plug/indicator</p>	<p>8. Low voltage ($\pm 5V$, $\pm 20V$, $\pm 36V$, $\pm 40V$) condition sensed.</p> <p>Pressing the FEHLER switch clears the Fault FF on the logic chassis, extinguishes the indicator, and clears Seek Finished and all bits of Error and DSB registers. If a fault condition is the only condition causing the absence of the Operable signal, the DSU will perform a Return to Zero Seek when the Fault FF is cleared.</p> <p>Indicator lights when plug is inserted into DSU. Each plug signals one of the nine DSU Address lines to the control unit. Lens of plug reflects the number corresponding to the line signalling the control unit. A DSU in which a plug labeled "S" is installed, will not be used by the control unit. Plugs are removable and interchangeable.</p>
<p>Logic Chassis Maintenance Panel</p>	
<p>- 20V, + 20V, - 36V, +36V, -5V, + 5V, + 40V, and GND test jacks</p> <p>ON LINE/OFF LINE switch</p>	<p>Afford a point at which dc voltages in the logic chassis can be measured.</p> <p>ONE LINE position places unit under control of control unit. Setting switch to OFF LINE position causes following:</p> <ol style="list-style-type: none"> 1. Prevents control unit from initiating Seek or Read/Write operations. 2. BEREIT (READY) indicator extinguishes. 3. WARTUNG (MAINTENANCE) indicator lights. 4. Inhibits return of Operable signal to controller.

TABLE 2-1. CONTROLS AND INDICATORS (Cont'd)

Control or Indicator	Function
STATUS toggle switch	<p>Toggle switch position determines signals to be sampled by Status Select switch as follows:</p> <ul style="list-style-type: none"> * NORMAL position selects File Bus In (FBIN) lines 0 through 7. * DSB1 Position selects the eight DSB1 register bits. * DSB2 position selects the eight DSB2 register bits.
Status Select Switch, STATUS indicator, and STATUS test jack	<p>Status Select is a 12-position rotary detent switch that allows sampling of 28 separate signals when used in conjunction with the STATUS toggle switch. STATUS indicator lights when the bit being sampled is set. Signal at STATUS test jack is "0" when the bit is set.</p>
CLEAR FAULT switch	<p>Clears Fault FF, Seek Finished, and all bits of Error and DSB registers when pressed.</p> <p style="text-align: center;">NOTE</p> <p>Due to the circuitry involved to clear the DSB registers it may be necessary to depress the switch twice to clear the fault.</p>
FAULT indicator	<p>Lights whenever one of the FF's in the Error register is set.</p> <p>Is not dependent upon position of Status Select switch.</p>
AIR FLOW indicator	<p>Lights to indicate adequate air flow within blower assembly.</p>
DC switch	<p>Set to ON position during normal operation. When set to OFF, removes power to spindle motor, and after spindle speed drops below 2000 rpm causes removal of all dc power to deck and logic cards (except receiver and transmitter cards). Causes operator panel WARTUNG indicator to light when set to OFF.</p>
<p>* Four Error flip-flop signals are hardwired to the four positions of Status Select switch and are always available, no matter what the position of the STATUS toggle switch is.</p>	

TABLE 2-1. CONTROLS AND INDICATORS (Cont'd)

Control Or Indicator	Function
Power Supply Panel	
± 5V ADJ, ± 20V ADJ, and +40 ADJ controls	Allow adjustment of the related dc voltage.
± 5V, ± 20V ADJ, ± 36V, +40V, and GND test jacks	Afford a point at which dc voltages in the power supply can be measured.
± 5V, ± 20V, +40V circuit breakers	Control application of related dc voltages to the logic chassis.
F1/3 AMP fuse	Protects the +20Y-vdc lamp power circuit.
F2/1 AMP fuse	Protects the -20-vdc interlock circuit.
F3/1 AMP/BRUSH MOTOR fuse	Protects the 20-vac brush motor drive circuit.
DC ON indicator	Provides a remote indication of the position of the logic chassis maintenance panel DC switch.
SPINDLE MOTOR circuit breaker and indicator (not applicable to units with serial number 825 or above)	Circuit breaker controls application of the ac voltage to the spindle drive motor. Indicator verifies application of voltage.
AC ON indicator	Lighted whenever circuit breaker in filter box is set to ON. Indicates that main input power is applied to the DSU power supply.
± 36V circuit breakers	Control application of the voltages to the positioner on the deck assembly.
Elapsed time meter	Indicates cumulative hours of spindle motor operation (pack rotating).

TABLE 2-1. CONTROLS AND INDICATORS (Cont'd)

Control Or Indicator	Function
Filter Box	
CB01 circuit breaker	Controls application of main ac power to DSU power supply. Power supply AC indicator lights when breaker is on.
Deck Assembly	
Track number indicator	Vernier scale located near top of carriage beside read/write heads. Readable only when top cover is raised. Fixed 0 mark identifies tens group for track. The coincidental fixed mark identifies the unit.

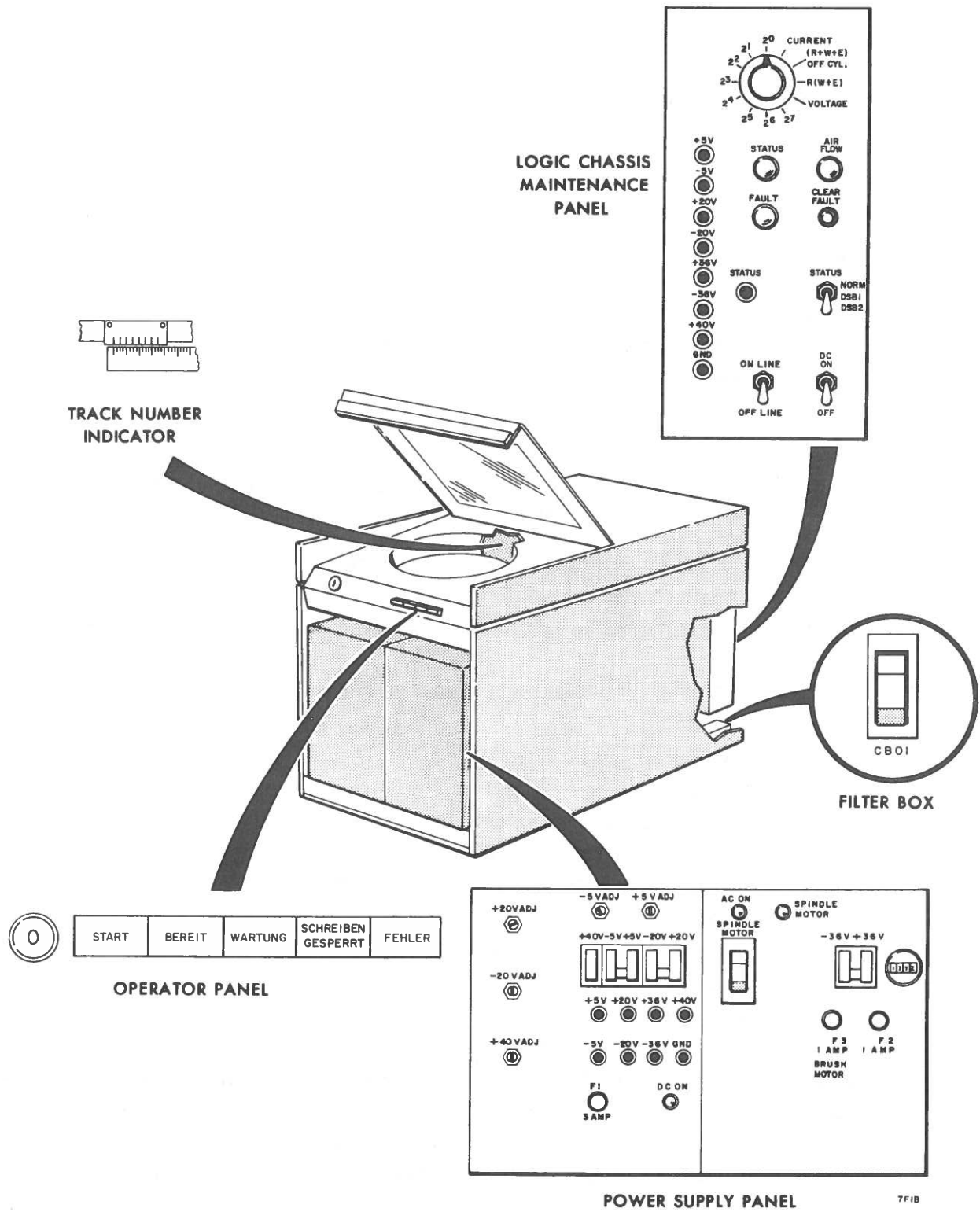

Figure 2-1. Controls and Indicators

OPERATING INSTRUCTIONS

DSU POWER APPLICATION

The following procedure prepares the DSU to go on line.

1. Make power available from control unit
2. Install a disk pack (refer to Disk Pack Installation paragraph).
3. Open the rear panel of the DSU cabinet and position the logic chassis maintenance panel switches as follows:

ON LINE/OFF LINE switch to ON LINE
DC switch to ON

NOTE

To prevent errors on adjacent units when operating in a system configuration, the $\pm 5V$ circuit breaker or DC switch must be off while turning the Filter Box circuit breaker on or off.

4. Set the filter box circuit breaker to ON. Close the rear panel. The blower motor will begin to operate.
5. Open the front panel of the DSU cabinet and position the power supply switches as follows:
SPINDLE MOTOR circuit breaker to ON (units with S/N 824 and lower only)
 $\pm 40V$ circuit breaker to ON
 $\pm 5V$ circuit breaker to ON
 $\pm 20V$ circuit breaker to ON
 $\pm 36V$ circuit breaker to ON
6. The following power supply panel indicators will light:
AC ON
SPINDLE MOTOR (units with S/N 824 and lower only)
DC ON
7. Close cabinet front panel
8. Press the operator panel START switch/indicator. The switch/indicator lights.
9. Operator panel BEREIT indicator normally lights when First Seek operation is complete.
10. The first Seek operation is complete when the heads are returned to track 00. The unit is now ready to receive a Read, a Write, or a Seek command.

DISK PACK INSTALLATION

Make certain that the disk pack to be installed has been cleaned and maintained according to the Preventive Maintenance instruction.

1. Raise the DSU front cover.

NOTE

A spindle lock mechanism is actuated when the front cover is opened. The mechanism holds the spindle stationary while loading a disk pack.

2. Lift the disk pack by the plastic cannister handle.
3. Disengage the bottom dust cover from the disk pack using the knob in the center of the cover. Set the cover aside to an uncontaminating area.

CAUTION

Avoid abusive contact between the disk pack and the spindle. During maintenance procedures the read/write heads are sometimes manually positioned. Make certain that the heads are fully retracted.

4. Place the disk pack onto the spindle.

CAUTION

Too rapid rotation of the pack, in the following step, will cause an impact force (at lock in) that may damage the lockshaft.

5. Twist the cannister handle clockwise while exerting a slight downward force. Continue twisting the handle until the resistance of the slip clutch is encountered.

CAUTION

Even though the cover may disengage before this resistance point is reached, continue to turn the cover to ensure full hold-down pressure is applied.

6. The pack is now locked in place. Lift the cannister clear of the disk pack and set it aside to an uncontaminating area.
7. Close the front cover immediately to prevent the entry of dust and the contamination of the disk surfaces.

DISK PACK REMOVAL

1. Press (to extinguish) the operator panel START switch.

CAUTION

A spindle lock mechanism is actuated when the front cover is opened. A loud ratcheting noise occurs when the front cover of a spinning disk pack is opened. While this action is not recommended, it will not damage the unit.

2. Check that disk pack rotation has stopped completely.
3. Raise the front cover on the DSU.

CAUTION

During maintenance procedures the read/write heads are sometimes manually positioned. Make certain that the heads are fully retracted.

4. Place the plastic cannister over the mounted disk pack so that the post protruding from the center of the disk pack is received into the cannister handle.
5. Twist the cannister handle counterclockwise until the disk pack is free of the spindle.

CAUTION

Avoid abusive contact between the disk pack and the spindle assembly.

6. Lift the cannister and the disk pack clear of the spindle.
7. Close the front cover of the DSU.
8. Place the bottom dust cover in position on the disk pack and tighten it.

SECTION 3

INSTALLATION AND CHECKOUT

INDEX AND GLOSSARY

INSTALLATION AND CHECKOUT

UNCRATING

During uncrating, care must be used so that any tools being used do not inflict damage to an assembly. As a cabinet is uncrated, inspect it for possible shipping damage. All claims for this type of damage should be filed promptly with the transporter involved. If a claim is filed for damages, save the original crating materials. Most crating materials will be reuseable if reasonable care is used uncrating. Uncrate DSU as follows:

1. Remove external packing material carefully.
2. Remove DSU from the container.
3. Open and latch the DSU top cover. Inspect the positioner, carriage assembly, and read/write heads for shipping damage.
4. Remove the tape from the top cover interlock switch.
5. Remove the four rubber shipping clicks located at the corners between the main deck and frame.

CAUTION

Do not position the carriage manually. Such action could cause the read/write heads to load and be damaged.

6. Remove nylon cord and CAUTION tag from carriage. Unscrew carriage lock mechanism that holds carriage immobile (located on deck at left side of carriage).
7. Open cabinet rear door.
8. Remove two non-metallic straps and wooden block securing logic chassis.
9. Remove tape securing power cable in bottom of cabinet.
10. Open and close the logic chassis assembly. If binding or drag occurs, adjust the upper and lower pivot brackets.
11. Remove access cover from rear of logic chassis. Check that all logic cards are firmly seated in their connectors, Install access cover.
12. Open cabinet front door. Remove tape securing primary filter to top of power supply.

13. Slide primary filter into place in base of cabinet (Figure 6-1).
14. Slide the power supply in and out of the unit. Replace any nylon rollers which do not move freely.

SPACE ALLOCATION

One DSU cabinet requires a floor area of approximately 2.3 x 3.2 feet. In addition, a 3-foot service access area to the front and rear of the unit should be provided.

LEVELING AND ALIGNING

1. Remove bag containing jack screws from bottom interior surface of DSU.
2. Carefully position a corner of cabinet over a depression or opening in the floor and install a jack screw adjacent to the caster. Repeat the process for the remaining three casters.
3. Position the DSU to its operational location and lower each jack screw until the casters no longer contact the floor.
4. Place a spirit level on main deck so ends of level point toward front and rear of deck.
5. Spirit level should indicate that surface is horizontal to within 3 angular degrees. Adjust jack screws until requirement is met.
6. Place spirit level on main deck so ends of level point toward sides of deck. Repeat step 5.
7. Cabinet is level when spirit level (oriented in both directions) indicates main deck horizontal to within 3 angular degrees and each cabinet caster is clear of floor.

CABLING AND CONNECTIONS

CABINET INTRACABLING

Inspect the cabling in the cabinet for agreement with Figure 3-1.

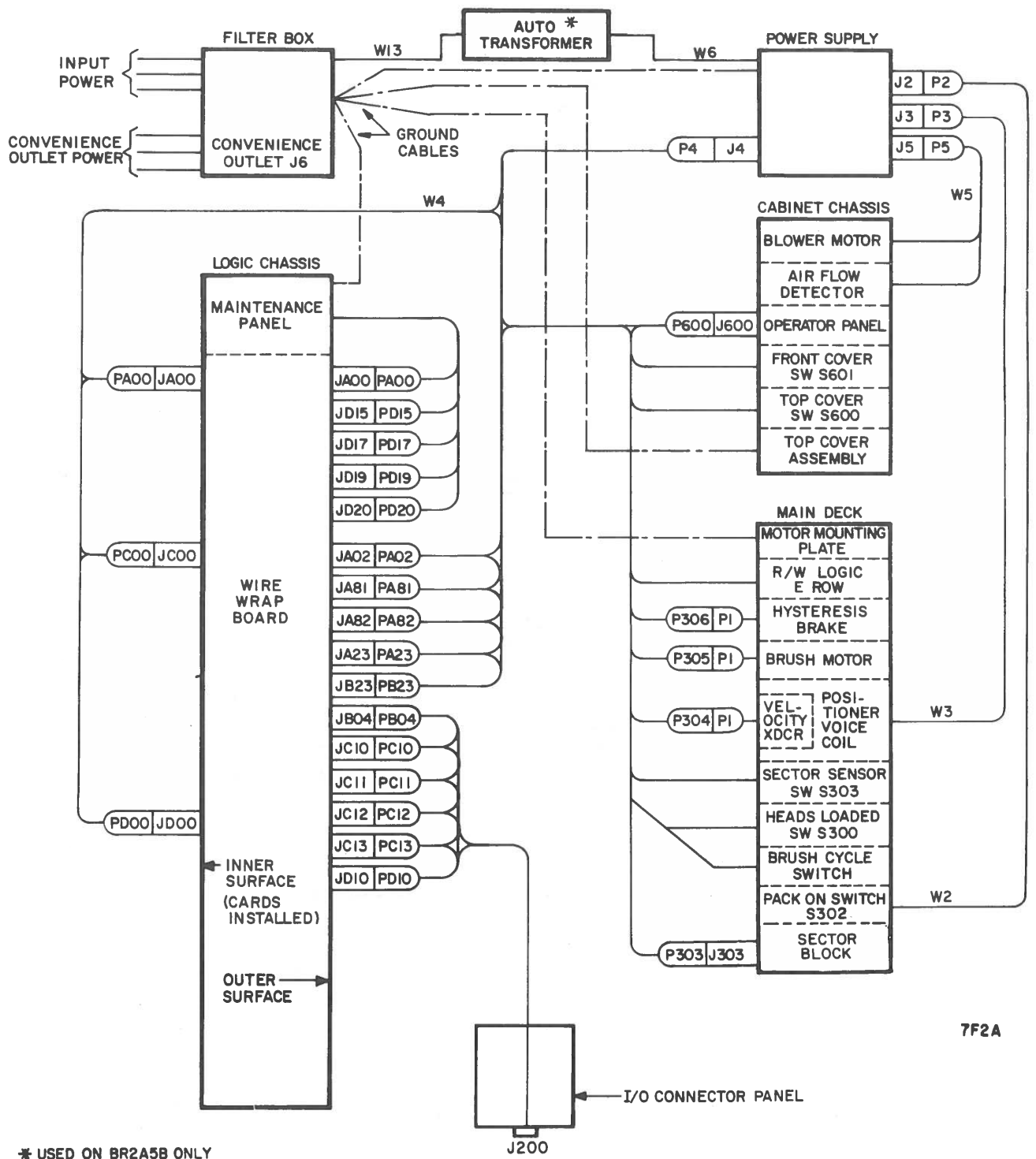

Figure 3-1. Cabinet Intracabling Diagram

INPUT/OUTPUT CABLES

CAUTION

Jack screws on logic chassis connecting cables must be alternately tightened or damage may result.

Refer to Figure 3-2 and install system input/output cables. All input/output cables exit the cabinet near the rear door. Table 3-1 provides information relative to the connector pin/signal assignments for these cables.

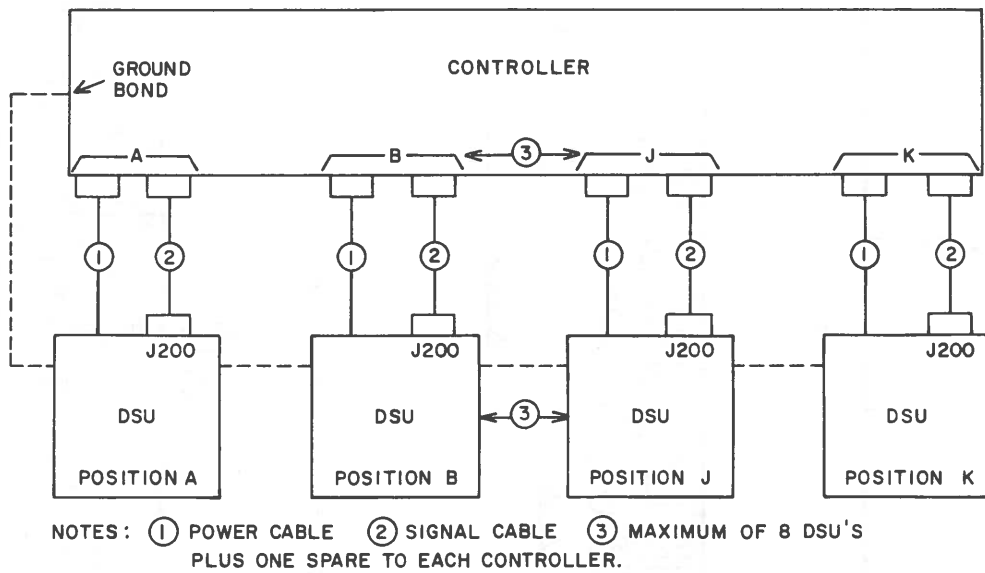

7E2

Figure 3-2. System Intercabling

TABLE 3-1. INPUT/OUTPUT CONNECTOR PIN ASSIGNMENTS

Input Signals via J200		Output Signals via J200	
Pins	Function	Pins	Function
47, 50	Write Data	32, 29	Read Data
2, 5	Command Tag	58, 62	Request Return
3, 7	Request Tag	73, 76	File Bus In 0
11, 14	Set Difference Tag	52, 55	File Bus In 1
24, 27	Set Head Tag	36, 39	File Bus In 2
65, 70	File Bus Out 0	23, 26	File Bus In 3
74, 77	File Bus Out 1	1, 4	File Bus In 4
80, 79	File Bus Out 2	8, 12	File Bus In 5
75, 78	File Bus Out 3	15, 18	File Bus In 6
67, 72	File Bus Out 4	28, 31	File Bus In 7
54, 57	File Bus Out 5	59, 63	Operable
48, 51	File Bus Out 6	41, 44	Address 0
30, 33	File Bus Out 7	35, 38	Address 1
46, 49	File Bus Out 8	42, 45	Address 2
53, 56	Controller Power Interlock (COP)	40, 43	Address 3
		34, 37	Address 4
		10, 13	Address 5
		17, 21	Address 6
		60, 64	Address 7
		66, 71	Address S
		16, 20	Mechanism Power Interlock (MEP)
		22, 25	Return to Zero Seek

POWER CABLES

Connect power cable to cabinet filter box as follows:

- a. Open cabinet rear door and swing logic chassis out.
- b. Remove rear screw securing filter box to cabinet frame and loosen front screw.
- c. Slide filter box back from forward screw and raise clear of cabinet.
- d. Remove two screws and washers securing cover on filter box.
- e. Make power cable connections to filter box interior.
- f. Install filter box by reversing steps a through e.

GROUND BOND

To minimize the effect of system generated noise, a ground bond (either a tinned copper braid of 7500 circular mils minimum or a copper strap of 5900 square mils minimum) must be connected between each DSU and the controller.

The ground bond is connected to the GND terminal on the filter box located in the rear of the cabinet below the logic chassis. The ground bonding scheme may be daisy chained or individually connected between each DSU and controller.

CABINET ACCESSORIES

Carefully insert appropriate Logic Number plug into hole to left of operator panel switches and push plug into receptacle.

INPUT POWER REQUIREMENTS

The DSU requires the following input power source:

- 208 volts ($\pm 10\%$), 3-phase, 60 ± 0.6 Hz BR2A5A
- 208 volts ($\pm 10\%$), 3-phase, 50 ± 0.5 Hz BR2A5B

NOTE

Although three-phase power is specified, power for this device is obtained between two phases.

The maximum current consumption with this input voltage is as follows:

Operating current (disk pack turning, steady-state)	7 amps
Standby current	3 amps
Surge current	22 amps drawn by spindle motor during start. (Decreases to operational level as motor approaches operating speed.)

ENVIRONMENT

Operating and storage environments of the DSU are as follows:

Operating status	16 to 32°C (60 to 90°F) (11°C/hr maximum fluctuation) 10 to 80% relative humidity (providing there is no condensation) (±15% maximum computer room temperature differential)
Non-Operating status	-34 to +66°C (-30 to +150°F) 5 to 95% relative humidity (providing there is no condensation)

INITIAL CHECKOUT AND STARTUP PROCEDURE

This procedure should be used to make the first power application to the DSU. The procedure assumes that the preceding procedures and requirements of this section have been performed and satisfied.

1. Set filter box circuit breaker to OFF.
2. Ensure that cabinet power cable is connected to correct external AC power source.
3. Open cabinet rear door. Swing logic chassis out and remove inner access cover. Check that all logic chassis cards are firmly seated in their connectors. Install access cover.
4. Open top cover.
5. Check that the five logic cards adjacent to shroud are seated securely in their connectors.
6. Grasp and turn the spindle.
7. The spindle should rotate with little resistance.

CAUTION

Bearing damage may occur if alcohol runs into spindle.

8. Wipe spindle surface clean with alcohol-dampened gauze.

CAUTION

Do not position the carriage manually. Such action could cause the read/write heads to load and be damaged.

9. Inspect and clean read/write heads and servo head (see Preventive Maintenance Index, Section 6).
10. Make certain that index transducer and pack cleaning brushes are rotated back from shroud openings.
11. Close top cover.
12. Use a vacuum cleaner to remove any dust or dirt from interior of shroud and cabinet.
13. Install disk pack.
14. Inspect and clean disk pack (see Preventive Maintenance Index, Section 6).
15. Set Logic Chassis Maintenance panel switches as follows:
 - ON LINE/OFF LINE switch to ON LINE
 - DC switch to ON
16. Set Power Supply panel switches as follows:
 - +40V circuit breaker to OFF
 - ±5V circuit breakers to OFF
 - ±20V circuit breakers to OFF
 - SPINDLE MOTOR circuit breaker to OFF (units with S/N 824 and lower only)
 - ±36V circuit breakers to OFF

17. Make power available from control unit.
18. Set the filter box circuit breaker to ON. Power supply AC ON and DC ON indicators light and cabinet blower begins to operate.
19. Set power supply +40V, ±5V, ±20V, ±36V, and SPINDLE MOTOR (units with S/N 824 and lower only) circuit breakers to ON.
20. Press Operator panel START switch/indicator. Indicator will light.
21. Spindle drive motor and disk cleaner (brush) motor start. Power supply elapsed time meter starts.
22. When disk pack reaches operational speed, the next DSU or group of DSU's (if any) is powered up.

NOTE

Further activity ceases until brush motor finishes driving the cleaning brushes over disk pack surfaces.

23. When brushes are returned to a position clear of disk pack, the positioner drives carriage forward to load read/write heads.
24. When heads are loaded, positioner returns read/write heads to track 00 and Operator panel BEREIT indicator lights.
25. Perform Head/Arm Adjustment procedure (see Corrective Maintenance).
26. Perform Index to Burst Check and Adjustment procedure (see Corrective Maintenance).
27. To stop spindle motor, press Operator panel START switch/indicator (indicator will extinguish). To remove power to DSU, set filter box circuit breaker to OFF.
28. Allow disk pack rotation to stop before opening front cover.

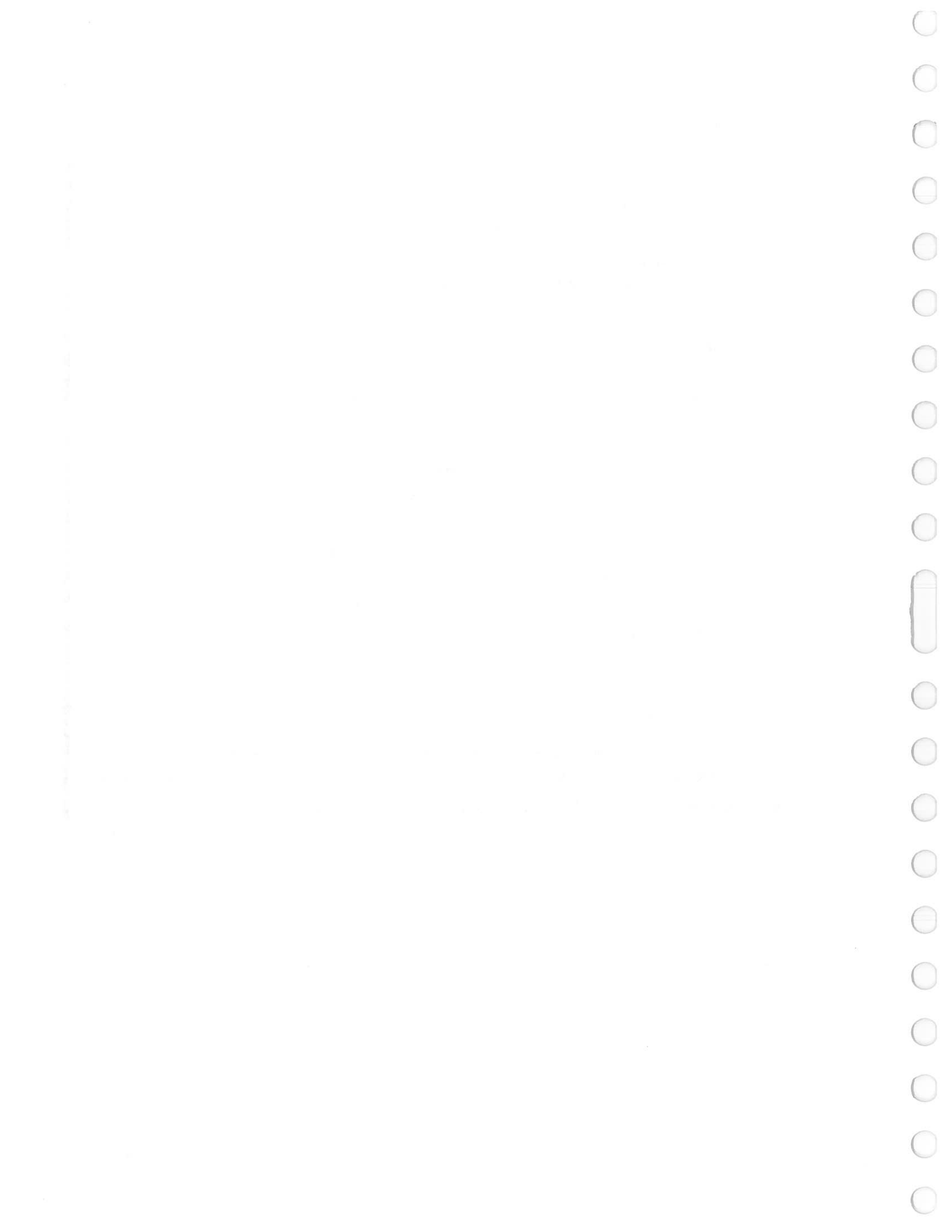

SECTION 4

THEORY OF OPERATION

THEORY OF OPERATION

Theory of operation for the DSU is divided into three parts. The first part considers the DSU in terms of the functions it performs and the signals exchanged with the controller. The second part relates the major assemblies of the DSU to the previously discussed functions. The last part deals with the disk pack which is physically not a part of the DSU, but figures functionally in all DSU operations.

FUNCTIONS

Overall capabilities of the DSU are best described by examining the functional blocks of activity performed by a DSU. The functions are as follows:

First Seek

Direct (Forward or Reverse) Seek (details Servo operation)

Return to Zero Seek (RTZS)

Read/Write/Erase

Each of these functions is further described by flow charts and timing diagrams in Section 5, Pub. No. 70614700.

The above functions are performed by each DSU. Normal operation is such that a controller will generally be directing the functional activities of more than one unit. Figure 4-1 shows the method of selecting and gating input/output data to a particular unit. Figure 4-2 details the sequence of events that establishes the link and gating. The signals that are then exchanged are described in Table 4-1 and are shown relative to a point of origin on Figure 4-3.

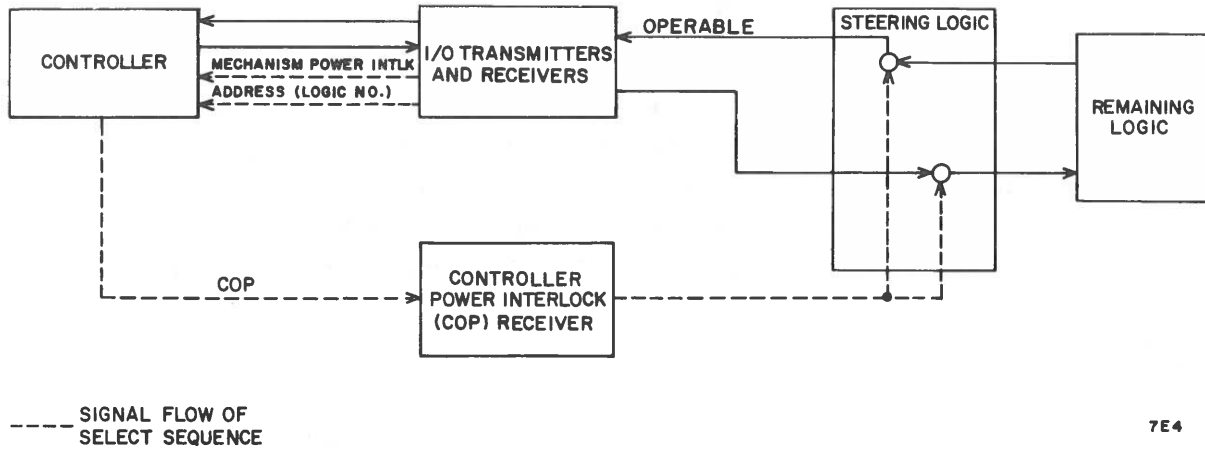

Figure 4-1. Input/Output Signal Gating

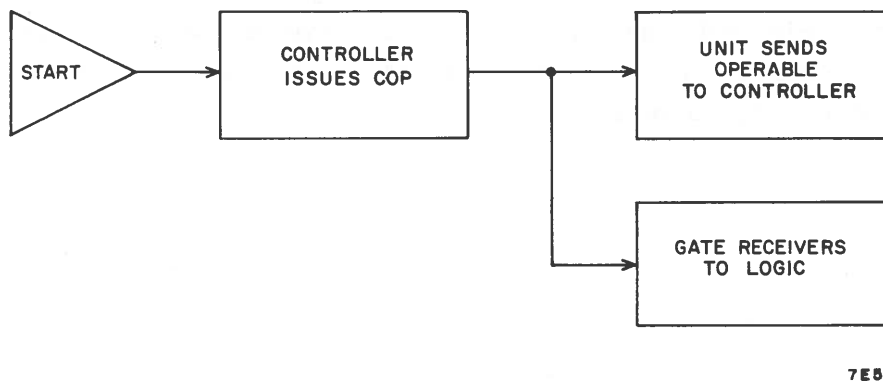
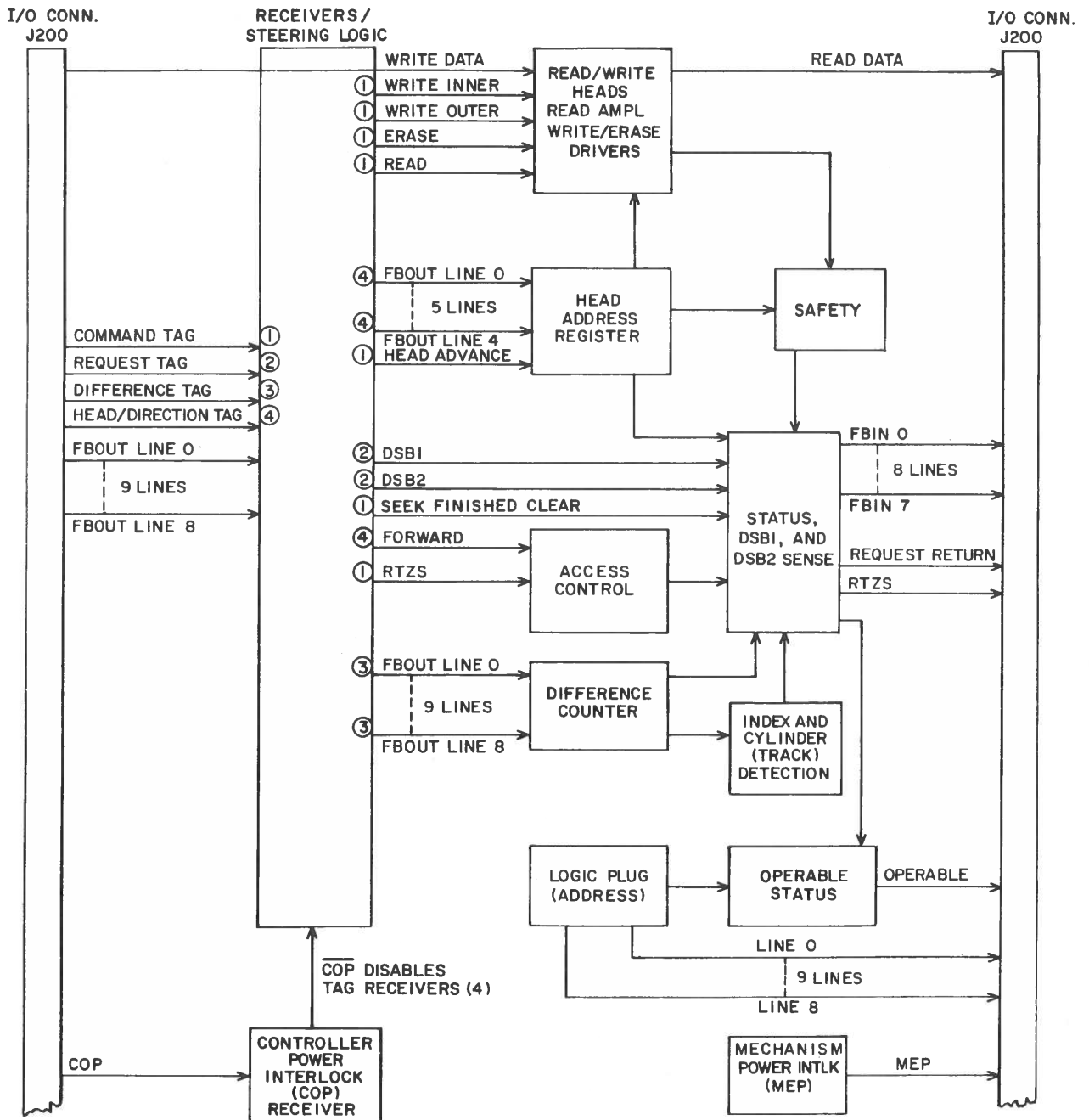

Figure 4-2. Select Sequence



7E6

Figure 4-3. Block Diagram

TABLE 4-1. INPUT OUTPUT LINES

Signal		Function		
<u>Input Lines:</u>				
Write Data		Carries information to be written from controller to the DSU.		
Controller Power Interlock (COP)		A -30 volt level indicates that the controller dc power is on and within tolerance. If the line is at ground level or open, the four tag line receivers will be disabled.		
File Bus Out (FBOUT) lines (9)		These lines function under control of four tag lines. Information on the lines cannot be interpreted unless the enabling tag line is known. Information coupled by each tag line is as follows (tag lines are defined immediately after FBOUT lines):		
File Bus Out Lines	Tag Lines			
	Difference Tag	*Head/Direction Tag	Request Tag	Command Tag
FBOUT 0	1	Head Address 1	DSB1 - A "1" gates content of DSB1 register to controller on FBIN lines.	Write Outer - A "1" enables write driver and specifies write current level required to write on an outer track.
FBOUT 1	2	Head Address 2	DSB2 - A "1" gates content of DSB2 register to controller on FBIN lines.	Write Inner - A "1" enables write driver and specifies write current level required to write on an inner track.
FBOUT 2	4	Head Address 4		Read - A "1" enables read data line.
FBOUT 3	8	Head Address 8		Head Advance - A "1" advances Head register content by a count of one.

TABLE 4-1. INPUT OUTPUT LINES (Cont'd)

File Bus Out Lines	Tag Lines			
	Difference Tag	*Head/Direction Tag	Request Tag	Command Tag
FBOUT 4	16	Head Address 10		Erase - A "1" enables erase driver to pass current through head erase coil erasing old information prior to writing new.
FBOUT 5	32	DSB Clear Disable - A "1" prevents clearing of Status Byte.	DSB Clear Disable - A "1" prevents clearing of Status Byte.	DSB Clear Disable - A "1" prevents clearing of Status Byte.
FBOUT 6	64			Return to Zero - A "1" initiates carriage movement to cylinder zero.
FBOUT 7	128	Forward seek: absence indicates Reverse seek.		
FBOUT 8	256			

*Head addresses are in 1-2-4-8 BCD code with decade 0 or 1 identified on FBOUT 4.
Example: To address head 18 requires a "1" on FBOUT 3 and FBOUT 4.

TABLE 4-1. INPUT OUTPUT LINES (Cont'd)

Signal	Function
Difference Tag	A "1" indicates that the FBOUT lines contain the difference address from control unit. This address is the difference between the control unit's current cylinder request and the DSU's present cylinder location.
Head/Direction Tag	A "1" indicates that the FBOUT lines contain head select and seek direction information. Head/Direction Tag is always preceded by Difference Tag which clears the Head Address register. The Head/Direction Tag clears the DSB1 and DSB2 registers unless accompanied by bit 5.
Request Tag	A "1" indicates that the controller desires to examine either the DSB1 (accompanying "1" on FBOUT 0) or the DSB2 (accompanying "1" on FBOUT 1) register content. The register contents are provided to the controller via the File Bus In (FBIN) lines described under Output Lines in this table. The occurrence of a "1" on Request Tag always causes a Request Return signal to the controller.
Command Tag	A "1" indicates that the FBOUT lines contain command information.
<u>Output Lines:</u>	
Address Lines (9)	These lines carry the address identifier of the DSU. The identifier is established by switch closures caused when the Logic Number Plug is manually installed to the left of the DSU Operator panel.
Operable	<p>A "1" indicates that each of the following conditions is satisfied:</p> <ol style="list-style-type: none"> 1. Disk pack up to speed and heads loaded. 2. Logic Number Plug installed. 3. A not File Unsafe condition exists (see FBIN lines). 4. COP signal being received. 5. ON LINE/OFF LINE switch is set to ON LINE position.

TABLE 4-1. INPUT/OUTPUT LINES (Cont'd)

Signal	Function								
Read Data	Transfers data read from DSU disk pack to controller.								
Mechanism Power Interlock (MEP)	A negative voltage level indicates that ac power is present in the DSU and that the DSU sequence relay K1 is energized.								
Return to Zero (RTZS)	A "1" indicates that the DSU is performing a RTZS operation. The "1" remains during the operation (approximately 250 ms).								
Request Return	A "1" indicates that a Request Tag is being received.								
File Bus In (FBIN) lines (8)	<p>These lines function to provide the controller with information relative to the DSU's status. Three separate sets of status information can appear on the FBIN lines. The origin of the three information sets and the signal conditions required to gate each set on to the FBIN lines is as follows:</p> <table border="0" data-bbox="682 1039 1429 1323"> <thead> <tr> <th data-bbox="682 1039 1023 1081"><u>Origin (in DSU)</u></th> <th data-bbox="1023 1039 1429 1081"><u>Signal Condition</u></th> </tr> </thead> <tbody> <tr> <td data-bbox="682 1081 1023 1144">1. DSU status logic</td> <td data-bbox="1023 1081 1429 1144">Not Request Tag (Normal)</td> </tr> <tr> <td data-bbox="682 1144 1023 1228">2. Device Status Byte register 1 (DSB1)</td> <td data-bbox="1023 1144 1429 1228">Request Tag AND FBOUT 0 (DSB1)</td> </tr> <tr> <td data-bbox="682 1228 1023 1323">3. Device Status Byte register 2 (DSB2)</td> <td data-bbox="1023 1228 1429 1323">Request Tag AND FBOUT 1 (DSB2)</td> </tr> </tbody> </table> <p>Information on the FBIN lines during the above signal conditions is described below.</p> <p>Signal Condition: Not Request Tag (Normal)</p> <p>FBIN 0</p> <p>Index - A "1" pulse indicates the beginning of a revolution of the disk pack. One pulse occurs each revolution.</p>	<u>Origin (in DSU)</u>	<u>Signal Condition</u>	1. DSU status logic	Not Request Tag (Normal)	2. Device Status Byte register 1 (DSB1)	Request Tag AND FBOUT 0 (DSB1)	3. Device Status Byte register 2 (DSB2)	Request Tag AND FBOUT 1 (DSB2)
<u>Origin (in DSU)</u>	<u>Signal Condition</u>								
1. DSU status logic	Not Request Tag (Normal)								
2. Device Status Byte register 1 (DSB1)	Request Tag AND FBOUT 0 (DSB1)								
3. Device Status Byte register 2 (DSB2)	Request Tag AND FBOUT 1 (DSB2)								

TABLE 4-1. INPUT/OUTPUT LINES (Cont'd)

Signal	Function
FBIN 1	<p>Busy - A "1" level indicates that the DSU is involved with execution an operation gated by Difference Tag, Head/Direction Tag, or Command Tag or is executing an internal operation such as an automatic RTZ.</p>
FBIN 2	<p>Seek Incomplete - A "1" level indicates that the DSU was unable to complete a seek operation. Seek Incomplete is accompanied by a "1" level on Seek Finished. <u>Seek Incomplete</u> can be cleared by Command Tag and <u>FBOU 5</u>.</p>
FBIN 3	<p>Write Return - A "1" level indicates that the DSU is in receipt of a Write (Inner or Outer) command and that SCHREIBEN GESPERRT is off.</p>
FBIN 4	<p>Seek Finished - A "1" level indicates the occurrence of one or more of the following:</p> <ol style="list-style-type: none"> 1. Completion of commanded direct seek operation. 2. Completion of commanded RTZ seek operation. 3. Seek Incomplete. 4. Completion of a First Seek type RTZS operation. This type of RTZS occurs as a result of one of the following: <ol style="list-style-type: none"> a. Initial system power up when DSU START switch is on. b. Any time DSU START switch is set to on (pressed to light). c. Recovery from the loss of power (ac or dc), open cover interlock, or pack-on interlock. 5. Completion of an automatic RTZS operation on the leading edge of Operable. This type of RTZS occurs as a result of one of the following: <ol style="list-style-type: none"> a. Inserting a Logic Number Plug. b. Setting the ON LINE/OFF LINE switch to ON LINE.

TABLE 4-1. INPUT/OUTPUT LINES (Cont'd)

Signal	Function
	<p>c. Clearing a File Unsafe condition.</p> <p>Seek Finished can be cleared by Command Tag.</p>
FBIN 5	<p>DSB1 Indicator - A "1" level indicates the occurrence of one or more of the following:</p> <ol style="list-style-type: none"> 1. Illegal head addressed by Head/Direction Tag. 2. Heads Unsafe condition. 3. Write Lockout Error condition.
FBIN 6	<p>End of Cylinder - A "1" level indicates that the Head Address register content has been incremented by a Head Advance pulse to a content of 19 or more.</p>
<p>FBIN 7</p> <p>Signal Condition: Request Tag AND FBOUT 0 (DSB1)</p>	<p>Not used.</p> <p>The content of the DSB1 register is cleared by any one of the following:</p> <ol style="list-style-type: none"> 1. <u>Trailing edge of Request Tag AND FBOUT 1 AND FBOUT 5.</u> 2. <u>Head/Direction Tag AND FBOUT 5.</u> 3. <u>Leading edge of Command Tag AND FBOUT 5.</u> 4. Pressing either FEHLER or CLEAR FAULT switches.
FBIN 0	<p>Not Seek - A "1" level indicates that a seek operation has been completed and that the difference counter content is zero.</p>
FBIN 1	<p>Zero Stop Error - A "1" level indicates that Seek Finished has occurred but that the content of the Difference counter is not zero.</p>
FBIN 2	<p>Not used.</p>
FBIN 3	<p>Seek Incomplete - A "1" level indicates that the DSU was unable to complete a (any) seek operation.</p>

TABLE 4-1. INPUT/OUTPUT LINES (Cont'd)

Signal	Function
FBIN 4	Write Lockout Error - A "1" level indicates that a Write (Inner or Outer) was attempted while the DSU was in the Write Lockout mode.
FBIN 5	Heads Not Loaded - A "1" level indicates that the read/write heads are not loaded.
FBIN 6	Up to Speed Failure - A "1" level indicates that the disk pack rpm has fallen below a specified value after it had been previously at or above that value.
FBIN 7	<p>File Unsafe - A "1" level indicates the occurrence of one or more of the following unwanted conditions.</p> <ol style="list-style-type: none"> 1. More than one head selected. 2. Read and Write (Inner or Outer) selected at the same time. 3. Read and Erase selected at the same time. 4. Erase and no write driver on. 5. Erase and both write drivers on. 6. One or both write drivers on and no erase driver on. 7. Read, Write (Inner or Outer), or Erase on and not in an on cylinder condition. 8. Low voltage situation that could cause a loss of control of write or erase currents. <p>An 85 μsec delay is started when either Write (Inner or Outer) or Erase changes state. If a fault condition of type 1, 4, 5, or 6 occurs during the delay, but does not exist after the delay times out, the Fault FF will not set and the occurrence is not detected. At any other time, fault conditions of type 1, 4, 5, or 6 are detected and the Fault FF will set in 15 μsec (nominal).</p>

TABLE 4-1. INPUT/OUTPUT LINES (Cont'd)

Signal	Function
Signal Condition: Request Tag AND FBOUT 1 (DSB2)	<p>The content of the DSB2 register is cleared by any one of the following:</p> <ol style="list-style-type: none"> 1. <u>Trailing edge of Request Tag AND FBOUT 1 AND FBOUT 5.</u> 2. <u>Head/Direction Tag AND FBOUT 5.</u> 3. <u>Leading edge of Command Tag AND FBOUT 5.</u> 4. Pressing either FEHLER or CLEAR FAULT switches.
FBIN 0	<p>Illegal Head Address - A "1" level indicates that an illegal head address was on the FBOUT lines (gated by Head/Direction Tag). The signal will not change from a "0" to a "1" if a Head Advance (gated by Command Tag) caused the Head Address register to contain an illegal head address.</p>
FBIN 1	<p>Write Return - A "1" level indicates that a Write (Inner or Outer) command was received.</p>
FBIN 2	<p>Read Return - A "1" level indicates that a Read command was received.</p>
FBIN 3	<p>Heads Unsafe - A "1" level indicates that the heads are in an unsafe condition. File Unsafe signal is a "1" at the same time.</p>
FBIN 4	<p>Erase Return - A "1" level indicates that an Erase command was received.</p>
FBIN 5	<p>Seek - A "1" level indicates that a (any) seek operation has occurred.</p>
FBIN 6	<p>Return to Zero - A "1" level indicates that a Return to Zero Seek command was received.</p>
FBIN 7	<p>Write Inner Track - A "1" level indicates that a Write Inner command was received.</p>

FIRST SEEK

This function involves the activities that a unit must perform before it can effectively respond to a Read, a Write, or a Seek command from the controller. This function consists mainly of power supply relay sequencing and status checking by the units logic. As a result, very little DSU/controller signal exchange occurs. Successful progression of the function assumes that power supply circuit breakers for the unit are on, power supply DC switch for the DSU is set to ON, power supply fuses are operational, related filter box panel circuit breaker is on, START indicators for unit are lighted, disk pack is installed on spindle of unit, and the cabinet covers (top and front) are closed.

Initiation of the function occurs when the last of the above conditions is met. This causes the power supply relay K1 to energize and the power supply performs a Power-On sequence (refer to Power Supply in this section for a detailed description).

Power is applied to the brush and spindle drive motors during the Power-On sequence. Application of power to the brush motor starts a 20-second (approximately) disk cleaning cycle. When the disk pack speed reaches 2000 rpm, the power supply relay K5 energizes to enable completion of the First Seek.

Transfer of the brush switch contacts at the end of the brush cycle sets the Load FF, Seek FF, and Forward Latch FF, and clears First Seek FF. It also causes the difference counter to be set to 495, and since the counter works with complements, this value amounts to a request for a 16-track seek. (Changing of the counter content will be inhibited until after the forward end of travel is sensed.) The net result is that the positioner performs a forward 16-ips access that mechanically loads the read/write heads. The carriage then continues forward until the forward end of travel is sensed. This occurrence causes the carriage to begin reversing. It also causes the content of the difference counter to change to 105 (complement of 406). As the carriage reverses and moves back inside of the forward travel, the difference counter content becomes 106 (complement of 405) as track 405 is crossed. With the difference counter calling for a 405-track seek, the positioner responds by performing a reverse seek to track 00 in the following sequence:

1. Accelerates to 50-ips and proceeds until 64 tracks remain.
2. Decelerates under control of the desired velocity generator from 50 ips to 25 ips which is maintained until 32 tracks remain.
3. Decelerates under control of the digital to analog converter during the next 31.5 tracks.
4. Moves the last one-half track and stops under control of the Fine Position Analog signal.

Refer to the Direct Seek paragraph for a detailed description of Servo Circuit operation.

The unit sends a Seek Finished signal to the controller 1.75 ms after reaching track 00. (A Seek Incomplete signal would have been sent instead if a 400-ms delay, starting when the seek motion first began, had timed out.) The deck is now ready to perform a Read, a Write, or a Seek (Direct or RTZS) operation. Such an operation must be preceded by the selecting sequence covered previously (Figures 4-1 and 4-2).

DIRECT (FORWARD/REVERSE) SEEK

The Direct Seek function involves those operations that must be performed to move the read/write heads from their current track or cylinder location to the one specified by the controller. This function must be preceded by the selecting sequence (Figure 4-1 and 4-2) unless the unit is already selected. Assume that the desired unit just completed a First Seek and is awaiting further instruction at track 00. Assume further that the controller wishes to do a Read or a Write operation at track 176. When the controller determines that the deck is ready, it calculates the difference between the unit's current and desired location and sends a Difference Tag that gates the complement of the seek length (complement of $176=335$) into the difference counter of the unit. Next the controller sends a Head/Direction Tag that gates the number corresponding to the desired read/write head into the Head register and commands the seek to start (in this example bit 7 would be a "1" to indicate a forward seek).

NOTE

Refer to Figures 4-4 and 4-5 and Table 4-2 during the following description. Servo circuit operation hinges generally on the relationship of the Position Error signal to the Velocity signal at the summing amplifier input. When Position Error exceeds Velocity, acceleration occurs. When Velocity exceeds Position Error, deceleration occurs. When Position Error amplitude is static and Velocity equals it, a velocity plateau occurs.

The Seek Forward gates the output of the position converter (Position Error signal) into the desired velocity function generator. (A Seek Reverse would have gated an inverted Position Error signal.) Since the seek length is greater than 32 tracks, the position converter output is clamped at a fixed voltage. Receipt of the Seek Forward signal also caused an Any Seek signal to occur. Any Seek gates the output of the desired velocity function generator (coarse position error) to the summing amplifier. Since the carriage is stationary, no Velocity signal exists to balance the Position Error, and forward motion of the carriage begins.

With the Position Error signal clamped at maximum, the power amplifier output (and voice coil positioner current) will be maximum and the carriage will continue to accelerate. As the carriage moves forward, outputs from the track servo head are processed to derive a cylinder pulse as each cylinder is crossed. Each pulse increases the content of the difference counter by one. When acceleration has increased to the point where the Velocity Amplifier signal and the Position Error signal cancel each other, the Summing Amplifier Control signal drops off. During this phase the carriage coasts along the 50 ips plateau with the power amplifier providing only enough output voltage to compensate for the back emf of the moving voice coil positioner.

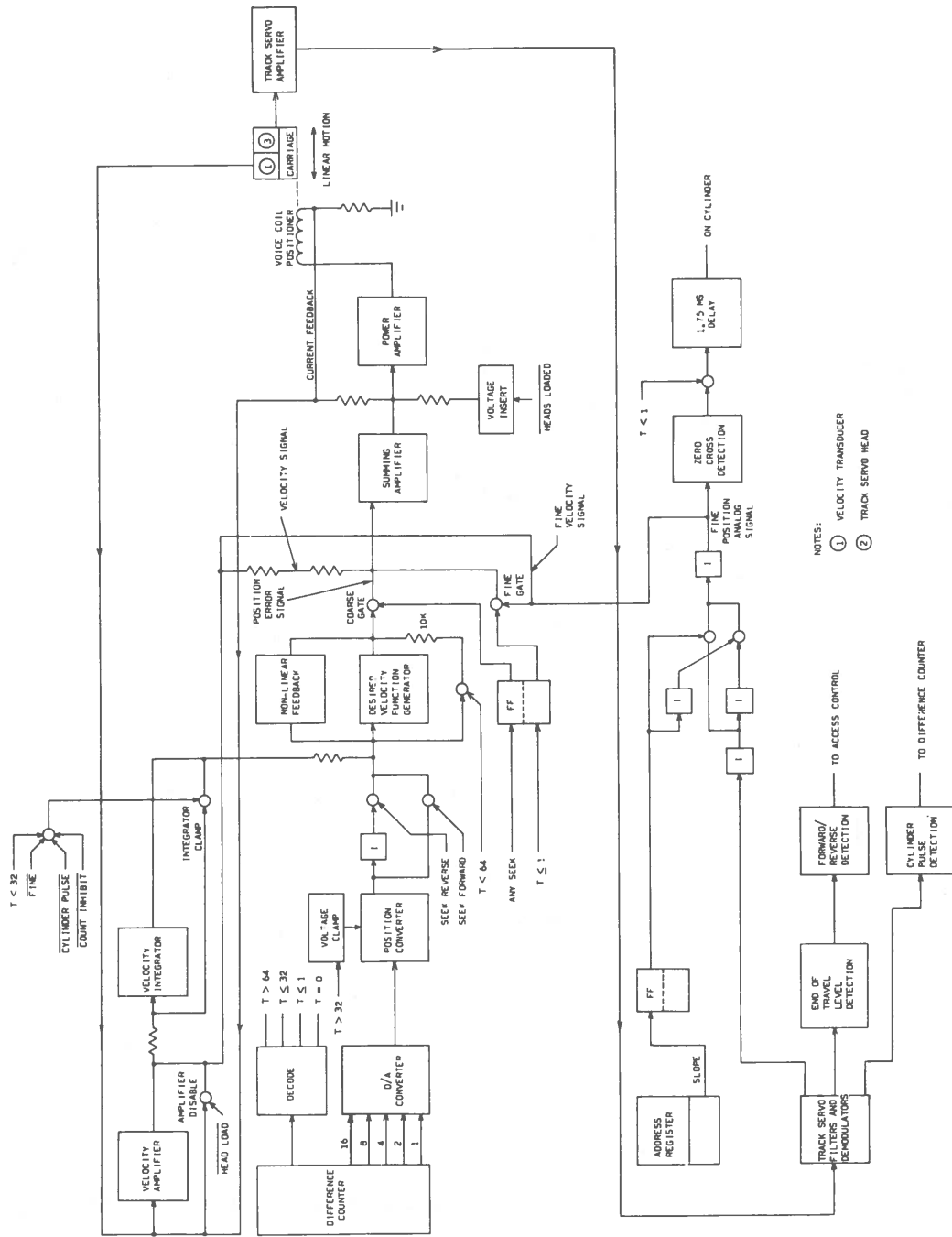
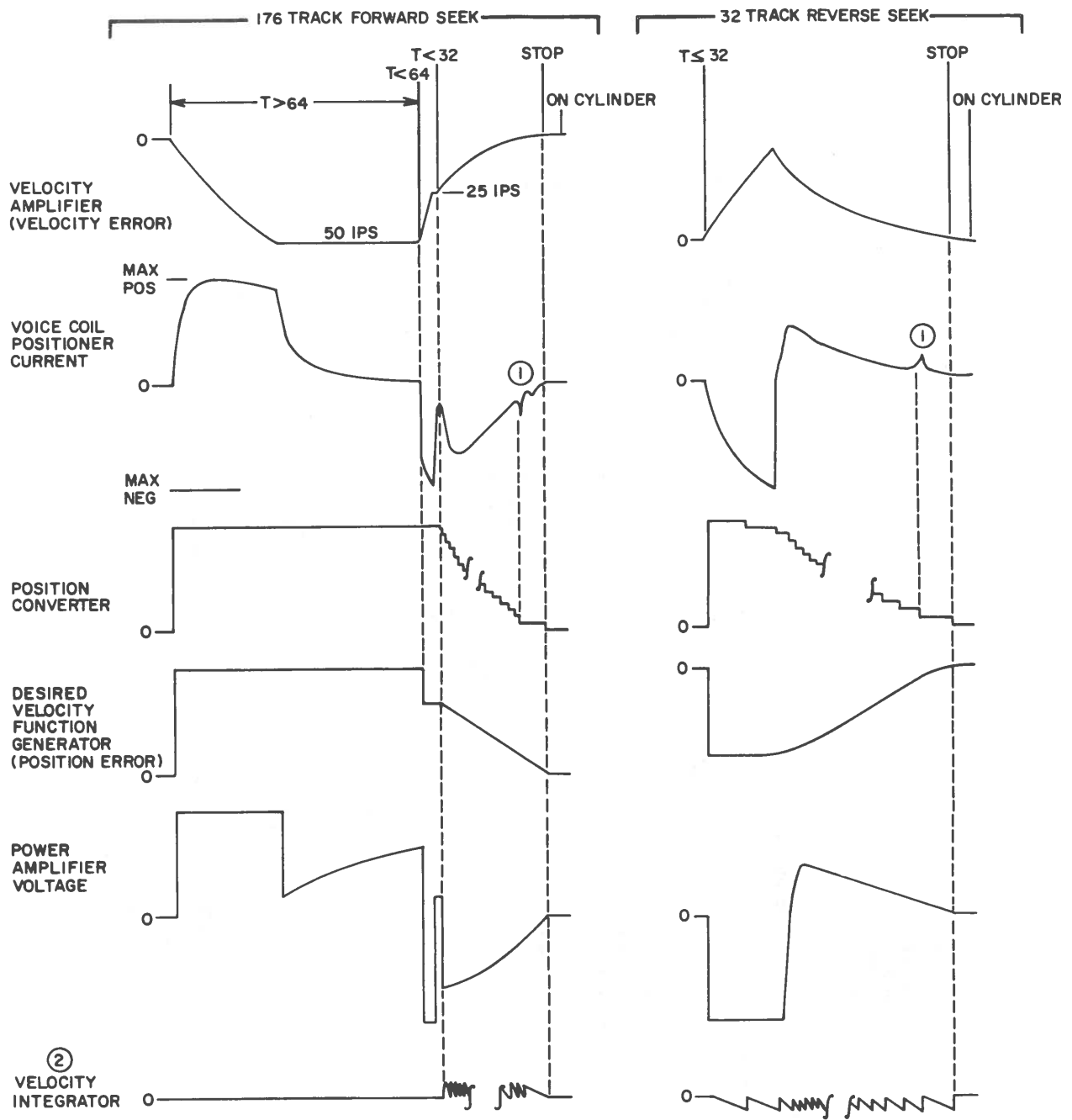

Figure 4-4. Servo Circuit Block Diagram



NOTE:

- ① CHANGE IN GAIN OCCURRING WHEN SEEK CONTROL SWITCHES FROM COARSE POSITION TO FINE POSITION ANALOG SIGNAL.
- ② ADDS PULSES AT INPUT TO DESIRED VELOCITY FUNCTION GENERATOR IN ORDER TO FILL IN (SMOOTH OUT) STEPPED SIGNAL FROM POSITION CONVERTER.

7F4

Figure 4-5. Typical Servo Signal Relationships

TABLE 4-2. SERVO CIRCUIT FUNCTIONS

Circuit Element (Figure 4-4)	Function
Difference Counter	<p>Holds the complemented count of tracks yet to be crossed before reaching the desired track or cylinder. An associated decoding network provides outputs representative of the current general content of the counter.</p>
Digital to Analog Converter	<p>Monitors the five lowest order bits of difference counter to provide an analog indication of Position Error during the last 32 tracks (except last track) of all Seek operations.</p>
Position Converter	<p>Provides coarse Position Error signal, the amplitude of which relates to the proximity of the desired track. Amplitude is clamped to highest point while tracks remaining are greater than 32. Amplitude decreases in discrete steps (controlled by D/A converter) as last 32 tracks of a Seek are crossed.</p>
Desired Velocity Function Generator	<p>Processes Position Error signal at gain levels that vary as Position Error decreases. When tracks remaining become less than 64, a low resistance (10K) negative feedback path is enabled that decreases generator gain. The parallel non-linear feedback circuit allows a gain of unity to exist until the Position Error falls within ± 2 volt band to either side of zero at which time the generator gain begins increasing as Position Error decreases. This gain increase prevents loss of control during the critical deceleration portion of the seek and is essential to minimize overshoot and settleout problems.</p>
Summing Amplifier	<p>Generates a control signal to drive the power amplifier. Control signal based on algebraic summation of position Error and Velocity signals. When Position Error exceeds Velocity Amplifier signal, control</p>

TABLE 4-2. SERVO CIRCUIT FUNCTIONS (Cont'd)

Circuit Element (Figure 4-4)	Function
Summing Amplifier (Cont'd)	signal causes power amplifier to accelerate carriage. When Velocity signal exceeds Position Error, carriage decelerates.
Power Amplifier	Responds to summing amplifier derived control signal to drive carriage mounted voice coil positioner. Current feedback is used to stabilize the gain of the power amplifier. Associated voltage insert forces a retract signal to be applied when heads are unloaded. This retract holds carriage retracted prior to being overridden by a forward drive at the beginning of a First Seek (load heads) sequence.
Velocity Amplifier	Amplifies signal of carriage mounted linear velocity transducer to provide an indication of velocity to the servo circuit. Also receives a negative feedback from positioner which acts to cancel current coupling that occurs from the velocity transducer location within the magnetic field created when current is applied to the voice coil positioner. The associated amplifier disable forces amplifier gain to zero during a Power Off sequence (unload heads). This is required so that coupling between the positioner field and the velocity transducer does not cause oscillation during movement to the retracted position.
Velocity Integrator	Provides an integrated representation of velocity between each of the last 32 track pulses of a Seek. Integrator is clamped off at all other times. Integrator output is applied to input of desired velocity function generator between each track pulse to fill-in or smooth out the stepped signal of the D/A converter (received via the position converter). Related integrator clamp forces integrator gain to zero at all times except as explained previously.

TABLE 4-2. SERVO CIRCUIT FUNCTIONS (Cont'd)

Circuit Element (Figure 4-4)	Function
Track Servo Amplifier	Amplifies the signal read by the track servo head prior to transmission to the track servo filters and demodulators (refer to Track Servo paragraph in the section).
Track Servo Filters and Demodulators	Filters the track servo signal into 455 KC and 500 KC components and demodulates them. These signals are then subtracted from each other in order to derive the fine position analog signal (refer to Track Servo paragraph in this section).
End of Travel Level Detection	Detects and switches in response to amplitude variations of the track servo signals.
Cylinder Pulse Detection	Observe switching level detection circuit to derive pulses representing tracks being crossed or carriage motion limits being passed. Cylinder pulses increment difference counter and gate velocity integrator.
Odd Flip-Flop	Used to select proper Demodulated Position signal for use as Fine Position Analog signal (signal controlling servo loop as last track is approached and carriage is stopped). If the seek destination is an odd numbered track, the odd track signal will be gated for use in stopping the carriage. If an even track is identified, the even track signal will be used.
Zero Crossing Detector	Detects Fine Position Analog signal transition to zero volts (carriage stopped). Detected zero crossing is delayed (allows any carriage vibration to settle out) prior to being issued as On Cylinder.

When the tracks remaining in the Seek become less than 64 (difference counter decoding) the gain of the desired velocity function generator is reduced. This causes a situation wherein the Velocity signal exceeds the Position Error signal. The servo immediately decelerates the carriage until the two signals again cancel each other. This results in a plateau (relatively short) at approximately 25 ips. The carriage proceeds on the plateau until the difference counter decoding indicates less than 32 tracks to go to the desired cylinder. At this point the position converter voltage clamp is disabled, and for the remainder of the Seek (except the last track) the servo position error is derived from the D/A converter. As each track is crossed the D/A converter output drops by a precise and linear amount. So that the Position Error provided at the desired velocity function generator input is not stepped, the integrator clamp gates the velocity integrator on between each cylinder pulse. The resulting integrator sawtooth output is added to the D/A converter output and fills-in the area between the leading edges of each step. As the Position Error decreases, the Summing Amplifier Control signal decelerates the carriage to keep the velocity Signal/Position Error signal difference to zero.

When the difference counter indicates one track to go to the desired destination, the coarse gate is disabled and the fine gate is enabled. The summing amplifier will now receive the Position Error from a new source and a second Velocity signal of higher gain is gated in.

Since the desired destination is track 176, Odd FF is "0". The FF's state causes inversions that result in a Fine Position Analog signal with a negative slope. As the carriage approaches track 176, the signal from the position transducer (Fine Position Analog signal) approaches zero volts (Figure 4-6). The summing amplifier responds to this decrease in amplitude by decelerating the carriage so that the sum of the Velocity signals always just cancels the Fine Position Analog signal. At track 176 both Velocity and Position Error equal zero, and all motion stops with the servo circuit at null. Only a Position Error will cause additional motion. When the Fine Position Analog signal reached approximately zero volts, a delay of 1.75 ms started. The On Cylinder (and Seek Complete or Seek Error) signal occurs when the delay times out. (A 400 ms delay was started by the Any Seek signal. If this delay had timed out before the occurrence of On Cylinder, a Seek Error signal would have been sent to the controller.) The unit is now ready to perform a Read, a Write, or a Seek operation.

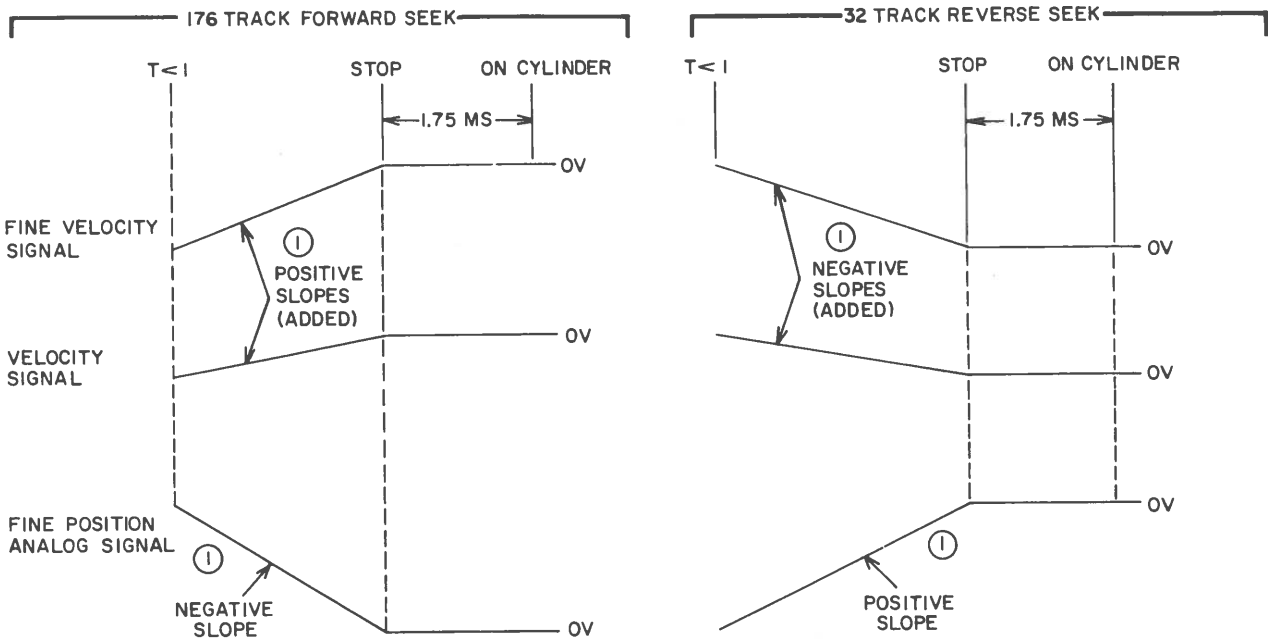

NOTE:

- ① SUMMING AMPLIFIER RESPONDS TO DECREASING AMPLITUDE OF FINE POSITION ANALOG SIGNAL BY DECELERATING CARRIAGE TO KEEP ALGEBRAIC DIFFERENCE BETWEEN VELOCITY SIGNALS AND POSITION SIGNAL EQUAL TO ZERO.

7F5

Figure 4-6. Fine Position Servo Signals

RETURN TO ZERO SEEK (RTZS)

The RTZS function allows a controller to return the read/write heads to track 00 when a Seek Error signal occurs. The controller responds to a Seek Error signal from a unit by sending a Command Tag that gates a "1" on bit 6 (RTZS pulse) to the afflicted unit. The RTZS pulse sets the Load FF, Forward Latch (FF), and Seek FF. It also causes the difference counter to be set to 495, and since the counter works with complements, this value amounts to a request for a 16-track seek. (Changing of the counter content will be inhibited until after the forward end of travel limit is sensed.) The net result is that the positioner performs a forward 16-ips access.

The carriage continues forward until the forward end of travel is sensed. This occurrence causes the carriage to begin reversing. It also causes the content of the difference counter to change to 105 (complement of 406). As the carriage reverses and moves back inside of the forward travel, the difference counter content becomes 106 (complement of 405) as track 405 is crossed. With the difference counter calling for a 405-track seek, the positioner responds by performing a reverse seek to track 00 in the following sequence:

1. Accelerates to 50 ips and proceeds until 64 tracks remain.
2. Decelerates under control of the desired velocity generator from 50 ips to 25 ips which is maintained until 32 tracks remain.
3. Decelerates under control of the digital to analog converter during the next 31.5 tracks.
4. Moves the last one-half track and stops under control of the Fine Position Analog signal.

Refer to the Direct Seek paragraph for a detailed description of Servo Circuit operation.

The unit sends a Seek Finished signal to the controller 1.75 ms after reaching track 00. (If the period starting when the seek motion first began had exceeded 400 ms, a Seek Incomplete signal would have replaced the Seek Finished signal.) The deck is now ready to perform a Read, a Write, or a Seek (Direct or RTZS) operation.

READ/WRITE/ERASE

A Seek Finished signal indicates to the controller that the selected DSU has completed a Seek operation and is awaiting further instructions. If, however, the controller initiated a Seek operation in one unit and then in the interim selected another unit, the first unit would make its status known via the Busy signal. The following paragraphs cover the sequence of events involved in a Read or Write operation.

The Head/Direction Tag gates the identifying number of the head to be used into the Head Address register. When the Seek is completed or a Seek Error is discovered, the unit sends a Seek Finished signal. Meanwhile, if the controller has selected another unit, this unit will stand by until it is reselected by the controller. In any case the controller will examine the Seek Incomplete and Seek Finished lines. If a Seek Incomplete exists, a RTZS pulse (sent by the controller) will clear it. If no Seek Incomplete exists, the controller responds with a Command Tag that gates in the Write and Erase (bits 4 and 0 or 1) with the Command Tag. Bit 0 forms the Write if the DSU is positioned on a track less than 256. At a track greater than 255,

bit 1 forms the Write. This disables the read circuit and enables the write circuit, and data from the controller is written via the Write Data line on to the disk pack record. The Erase signal enables erase current to the erase coil during the Write operation.

A Read operation is performed in much the same manner as the Write operation. The difference is that Command Tag gates bit 2 for a Read.

ASSEMBLIES

POWER SUPPLY

Each DSU cabinet has a self-contained power supply accessible via the front door. The power supply provides a fixed output voltage of ± 36 volts for use by the voice coil positioner on the deck assembly. It also provides adjustable output voltages of +40 vdc (to read/write logic), ± 20 vdc (to logic), and ± 5 vdc (to logic). Basic ON/OFF power control and monitoring is provided at the front panel of the assembly. The front panel, as well as the top surface, is hinged so that access can be gained in the event of maintenance requirements. The power supply is cooled by air delivered through two flexible ducts from the blower assembly.

AC/DC Distribution (Figure 4-7)

Input power is made available to the power supply via the closed contacts of the filter box panel circuit breaker. The presence of the primary input power at the power supply is indicated by the power supply AC ON indicator. This input power is applied to the blower motor (located in the lower part of the cabinet) via step-up transformer T9. Input power is also applied to the primaries of T1 and T6 at this time (on units S/N 824 and below the spindle motor circuit breaker must be set to ON). The same voltage is applied to the solid-state switches, SSW1, SSW2, SSW3, and Start Timer for the spindle motor, though the voltage is not actually applied to the motor until during the Power-On sequence (described in a later paragraph). An ac voltage (approximately 24 volts) is picked off the secondary of T1 and applied to SSW4 for the brush motor, but again application of the voltage to the motor does not occur until the Power-On sequence.

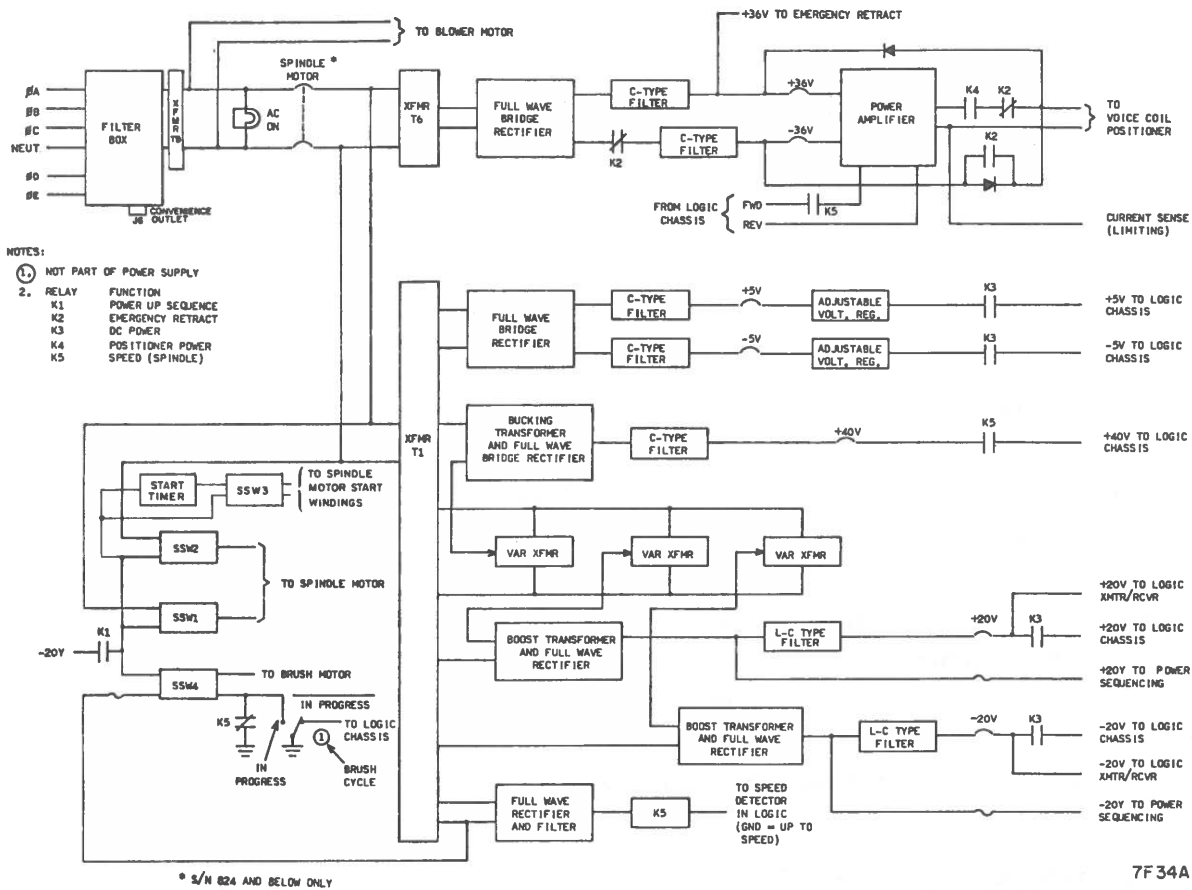

Figure 4-7. Power Supply - AC/DC Distribution

The dc power distribution begins with the application of input power to the primaries of T1 and T6 (SPINDLE MOTOR circuit breaker to ON). In the case of T1, four distributable voltages developed across the secondary windings are applied to rectifier/filter circuits. (A fifth voltage is similarly derived but is used exclusively by relay K5.) Three of the four circuits (+40v, +20v, and -20v) incorporate boost/buck transformers with variable transformers included for adjustability. Both polarities of the five-volt circuit incorporate a voltage level regulator which includes the adjustment control in the form of a variable resistor. The ±20V voltages used in the power sequencing circuit are available as soon as the primary of T1 receives power. The same is true for the ±20 voltages used by the units transmitters and receivers. Sequencing of power is required to determine the status of various

unit components during a Power-On sequence. The remainder of the T1-derived dc voltages are distributed by circuit breakers and relay contacts.

The voltages developed across transformer T6 are similarly rectified and filtered. Circuit breakers control application of the voltages to the voice coil positioner power amplifier.

Power-On Sequence

Power application to a unit is switched by relays in the controller. Sequencing within a DSU is required to prevent damage to read/write heads and/or disk packs.

A normal On Line, Power-On sequence begins when switch S501 on the operator panel is pressed so as to light the related indicator. The progression of the sequence assumes that all power supply circuit breakers are on, that all power supply fuses are operational, that the DC switch is set to ON, that a disk pack is installed, that the disk pack cover has been removed, that the cabinet top and front covers are closed, and that sequence voltage to relay K1 is available.

NOTE

Although step 1 occurs prior to pressing S501, it is considered a part of the Power-On sequence.

1. When the filter box circuit breaker was set to ON, the blower motor started, ± 20 volts was applied to the logic transmitters and receivers (only), and $\pm 20V$ voltage became available (Figure 4-7).

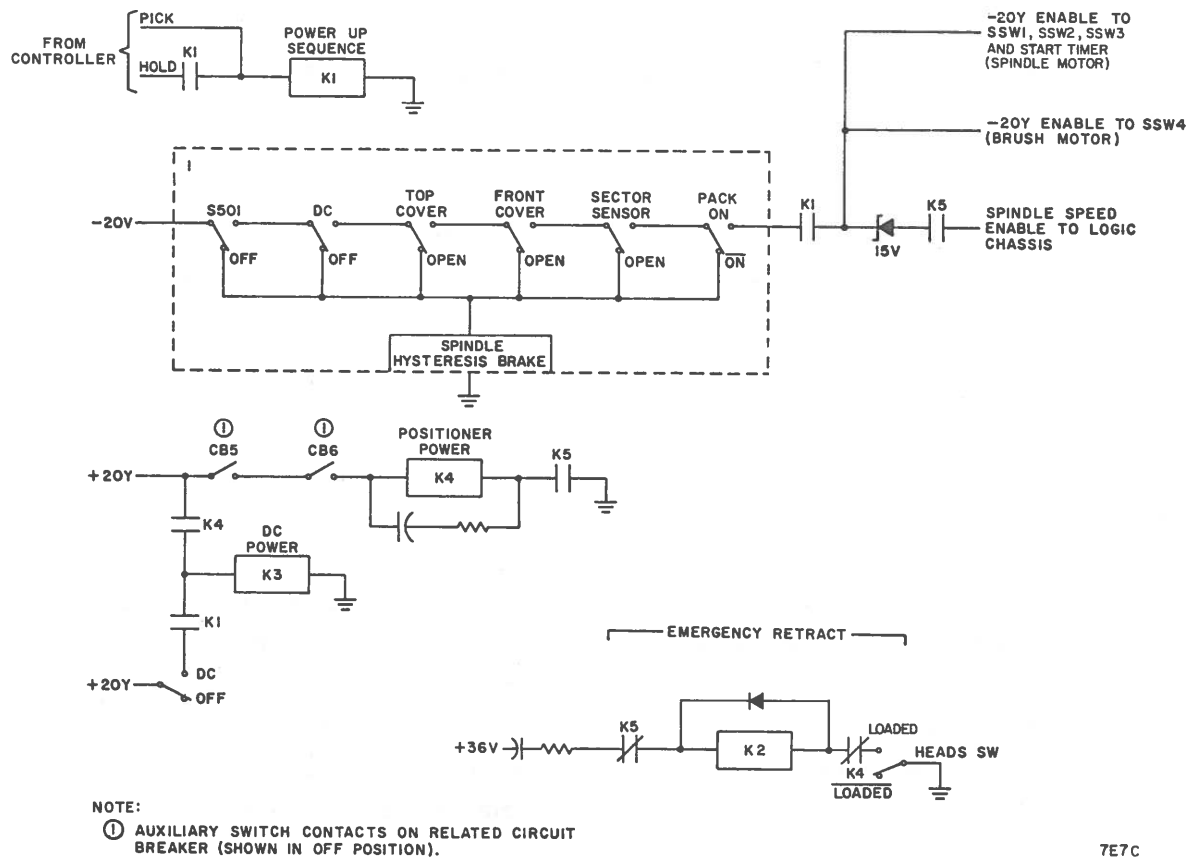

Figure 4-8. Power Supply - Sequencing

2. Press operator panel switch S501 (Figure 4-8).
3. Closing contacts of K1 cause the following:
 - a. Apply holding current to the armature of relay K1.
 - b. Apply -20Y volts to solid-state switches SSW1, SSW2, SSW3, SSW4, and Start Timer (Figures 4-7 and 4-8). This enables the solid-state switches to conduct the previously applied ac power. The spindle motor and brush motor start and the brush cycle switch transfers to the in-progress position. SSW3 switches the spindle motor start windings and drops out at approximately 1000 rpm.
4. The closing contacts of K3 distribute ± 5 vdc and ± 20 vdc to the logic chassis (Figure 4-7).

5. When the logic chassis speed detection determines that the spindle speed is adequate, relay K5 energizes. The contacts of K5 cause the following:
 - a. Distribute +40 volts to the read/write logic.
 - b. Send a Speed Enable signal to the logic chassis (Figure 4-7).
 - c. Remove one of two grounds to SSW4 which is controlling the operating brush motor (Figure 4-7).
 - d. Energize relay K4 (Figure 4-8).
6. The transferring contacts of K4 cause the following:
 - a. Apply an additional +20 volt line to the armature of relay K3 (Figure 4-8).
 - b. Connect the power amplifier to the positioner so that the logic may begin providing motion commands to the positioner (Figure 4-7).
7. As the disk pack cleaning brushes return from sweeping the disk surfaces, the brush cycle switch mechanically transfers to the not-in-progress position. This removes the remaining ground to SSW4 and disables the brush motor. It also signals completion of the brush cycle to the logic chassis (Figure 4-7).
8. Completion of the brush cycle allows the start of the First Seek (load heads) function. Upon completion of the First Seek operation the unit is ready to respond to commands from the controller.

Power-Off Sequence

The normal Power-Off sequence begins when the operator panel switch S501 is pressed so as to extinguish the related indicators. The progression of the sequence is as follows:

1. Press operator panel switch S501 (Figure 4-8). The -20Y voltage is switched to cause the following:
 - a. Absence of -20Y voltage to SSW1 and SSW2 removes ac voltage to spindle motor.
 - b. Presence of -20Y voltage at spindle hysteresis brake causes rapid deceleration of disk pack.
 - c. Spindle speed enable to logic chassis drops. This disables read/write logic and causes the carriage to begin moving in reverse toward a point where the read/write heads unload.

2. When the logic chassis speed detection determines that the spindle speed is below 2000 rpm, relay K5 de-energizes causing the following:
 - a. Removes +40 volts to the read/write circuits (Figure 4-7).
 - b. Opens the ground side of relay K4 (Figure 4-8). However, the capacitor in parallel with the K4 armature will take approximately 300 ms to discharge during which time K4 remains energized.
 - c. Applies +36 volts to the armature of relay K2 (Figure 4-8). However, the capacitor in parallel with the K2 armature will take approximately 400 ms to charge during which time K2 remains de-energized.
3. If the heads loaded switch has transferred (indicating heads are not loaded) prior to K5 de-energizing, or if it transfers before relay K2 energizes, the carriage continues in reverse at 16 ips to the retracted stop. When K4 de-energizes, its contacts disconnect the power amplifier from the positioner (Figure 4-7) and the Power-Off sequence is completed.
4. If, however, the heads are still loaded when relay K2 energizes, the contacts of K2 will cause an emergency retract as follows:
 - a. One set of contacts disconnects the rectifier from the -36-volt side of the power amplifier (Figure 4-7). Another set gates the -36-volt line directly to the positioner.
 - b. The charge stored on the -36-volt capacitive filter discharges through the positioner causing the carriage to be retracted at approximately 60 ips.
 - c. When the heads unload, relay K2 de-energizes. The carriage is at the retracted stop and the Power-Off sequence is complete.

LOGIC CHASSIS

The logic chassis assembly consists of a logic card section and a maintenance panel. The assembly is accessible through the cabinet rear door. One end of the assembly is hinged to allow access to the front and rear surfaces of the chassis as well as to elements mounted on the underside of the deck. A flexible hose delivers air from the blower housing to the logic chassis. The blower fan is energized whenever the filter box circuit breaker is on, and provides cooling air to the logic card section. The front and back covers of the assembly can be removed (four half-turn fasteners each cover) to gain access to cards, wire wrap pins, and related wiring.

The logic card section contains the bulk of the logic cards used in the cabinet (five cards are located on the deck assembly). The vertically mounted cards are installed in four rows (A top row and D bottom row) at numerically identified locations. Some cards span two rows and are referred to as full-size cards. Others span a single row and are called half-size cards. Refer to Section 5, Pub. No. 70614700, for a description of the logical functions performed by the cards. Section 7 provides a physical description of the cards. Section 9 contains a tabulation of the wire wrap connections made in the chassis.

The maintenance panel contains a set of test point jacks, switches, and indicators that relate to the operational status of the deck for the unit. These components function primarily to isolate the occurrence of a fault in the unit. Specific information on each control or indicator of the panel is provided in Section 2 of this manual.

DECK ASSEMBLY

The deck assembly (Figure 4-9) is responsible for the dynamic operations of a DSU; driving disk packs, and loading and positioning the read/write heads. The deck assembly consists of a deck plate on which are mounted a drive motor assembly, a spindle assembly, a hysteresis brake assembly, a carriage and carriage track, two transducers, a disk cleaner assembly, and a magnet assembly.

Drive Motor Assembly

The drive motor drives the spindle assembly. The motor is an induction type, 1/2-hp unit. The motor is secured to a mounting plate. The mounting plate is secured to the underside of the deck plate in such a manner as to control belt tension. Power is transferred to the spindle via a flat, smooth-surfaced belt that threads over the pulleys of the spindle and drive motor. An idler spring maintains a constant tension on the motor mounting plate, and hence, the belt.

A second pulley on the drive motor shaft links the motor (via a V-belt) to the hysteresis brake.

The temperature of the motor is monitored by a thermal protection switch. To restore operation after an over-temperature condition, the red, 1/4-inch button on the lower end of the motor must be manually reset (pressed).

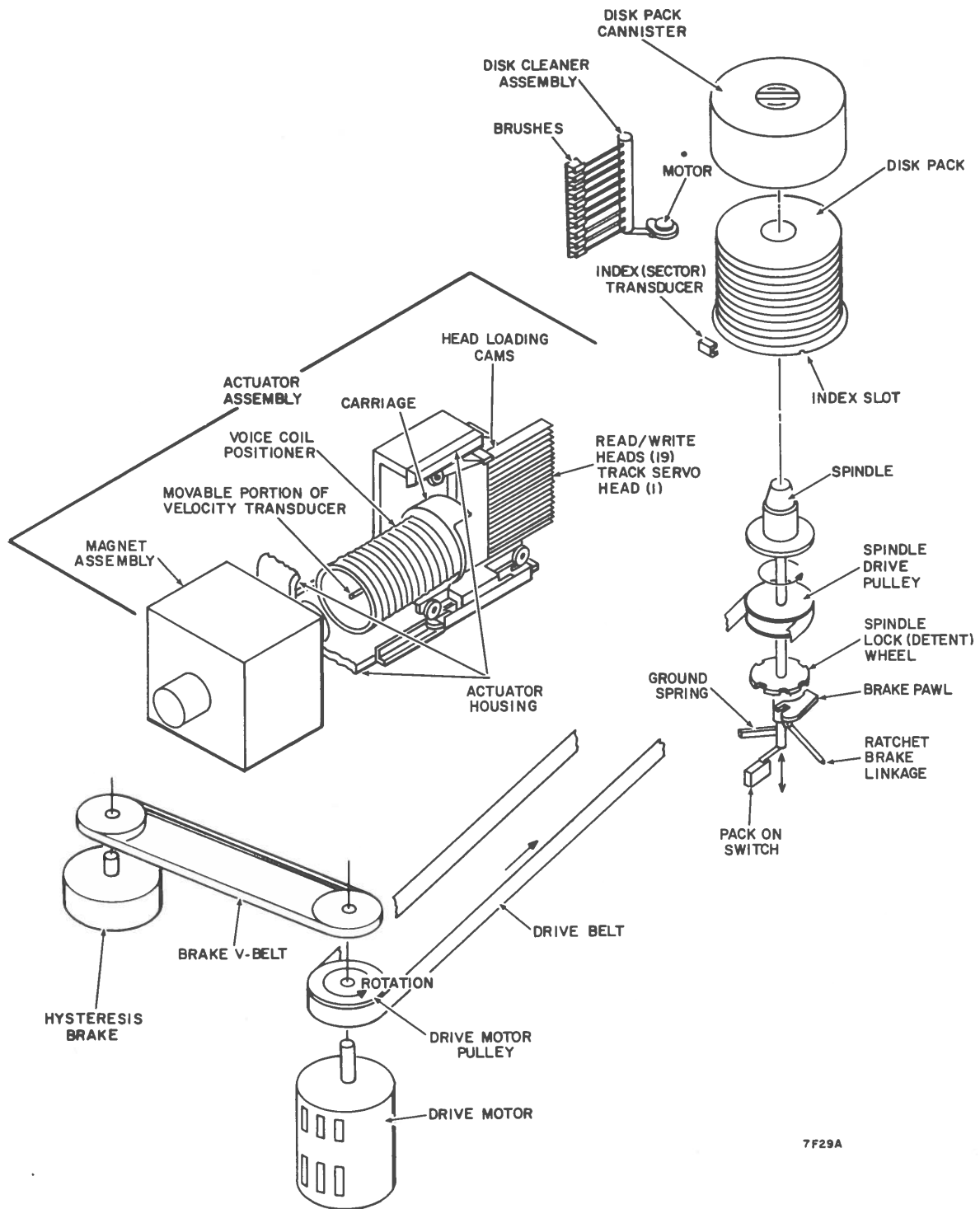

7F29A

Figure 4-9. Deck Assembly

Hysteresis Brake Assembly

The hysteresis brake decelerates the drive motor assembly during a Power-Off sequence (refer to Power-Off Sequence paragraph). The brake mounts on a plate which is in turn mounted on the motor mounting plate. The brake and motor shafts are linked via a V-belt and a pulley on each shaft.

The brake consists of two cylindrical permeable bodies. These cylinders are assembled, one inside the other, with a uniform gap separating the outer diameter of one from the inner diameter of the other. These adjacent surfaces are machined to contain a series of pole faces. A permanent magnet, in the shape of a cup, fits in the gap to separate the cylinders. This cup is connected to the brake shaft. As long as spindle motor power is applied brake power is not available and the cup is driven at the speed of the motor. When spindle motor power is removed, braking power is applied. As braking voltage (-20 volts) is applied to the inner cylinder, a flux field is created between the inner and outer cylinder pole faces. The flux field sets up what is in effect magnetic friction between the inner cylinder and the cup, causing the cup (and brake shaft) to decelerate. Brake deceleration in turn causes spindle motor deceleration.

Spindle Assembly

The spindle assembly is the physical interface between a SDU and a disk pack. The conical surface of the spindle cone (Figure 4-10) mates directly with the cone shaped opening in the center of the disk pack.

Starting in the spindle cone and running through the center of the spindle assembly is the vertically free-floating lockshaft. The upper end of the lockshaft contains internal threads that engage the external threads of a stud projecting from the disk pack. When the disk pack cannister cover handle is rotated clockwise, the spring-loaded lockshaft is pulled upward and the disk pack is pulled down. As a result, the conical surfaces of the disk pack and the spindle cone are engaged by a force of approximately 200 pounds. When the disk pack is fully engaged, a release mechanism in the cannister handle frees the cannister from the disk pack.

A notched wheel is secured to the bottom surface of the drive pulley. The notches of the wheel are engaged by the tip of the spindle lock pawl (Figure 4-9) when the front cover is fully open. This locks the spindle, making it easier to install or remove a disk pack. Opening fully the front cover of an operating deck will cause a loud

ratcheting noise. Such action, while not recommended, will not cause damage. The spindle drive pulley is driven by a flat belt linking it to the drive motor pulley.

A friction plate and pad comprise a clutch mechanism that protects the lockshaft from damage that could result from improper disk pack loading technique.

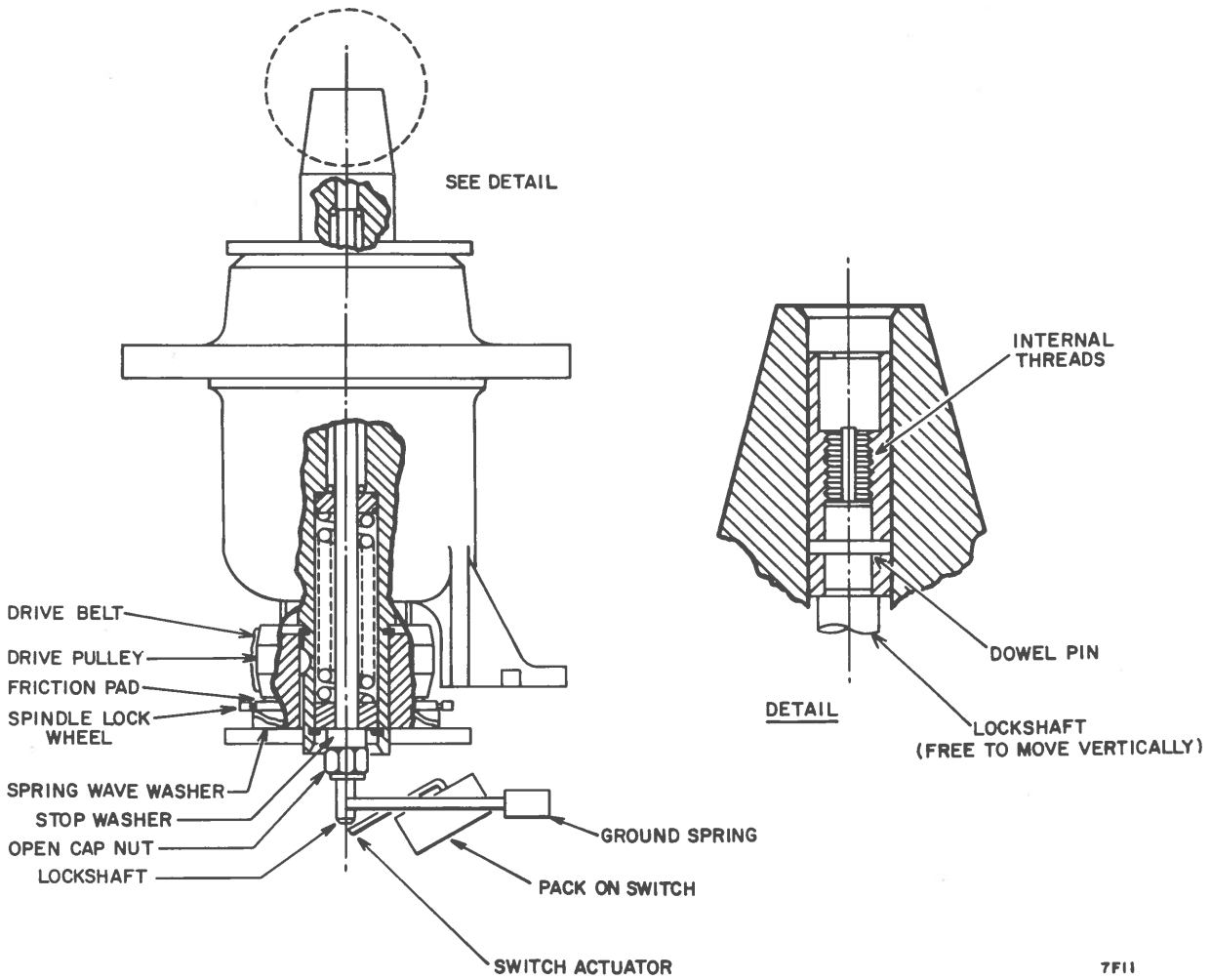

Figure 4-10. Spindle Assembly

The pack-on switch and ground spring are mounted at the lower end of the spindle assembly. The ground spring is mounted so that it is always in contact with the lockshaft to bleed off any accumulation of static electricity on the spindle to the deck through a ground strap. The pack-on switch contacts transfer in response to the vertical movement of the lockshaft. When the shaft is up (disk pack mounted) the contacts are closed. When a pack is not installed, the shaft moves downward to deflect the switch actuator and transfer the contacts. The switch is part of the inter lock that stops application of power to an improperly configured unit.

Actuator

The actuator consists of the carriage, actuator housing, and magnet assembly. The actuator (Figure 4-11) is the device that supports and moves the read/write and track servo heads. The lateral forward and reverse moves of the carriage on the carriage track are controlled by a servo signal. The basic signal is developed in the logic section and processed by a power amplifying stage in the power supply. The power amplifier output is applied to the voice coil positioner (part of carriage). The signal causes a magnetic field about the voice coil positioner. This magnetic field reacts with the permanent magnetic field existing around the magnet assembly. The reaction either draws the voice coil into the permanent magnet field or forces it away. Signal polarity determines the direction of motion, while signal amplitude specifies the velocity of the motion.

The voice coil positioner is a bobbin-wound coil that is free to slide in and out of the forward face of the magnet assembly. Fastened to the positioner is a head/arm receiver which holds the 19 read/write heads and the single track servo head. The head/arm receiver mounts on the carriage and bearing assembly that moves along the carriage track on eight bearing type rollers. Movement of the positioner in or out of the magnet causes the same motion to be imparted to the entire carriage assembly. This linear motion is the basis for positioning the read/write and track servo heads to a particular track of data on the disk pack. (Refer to Head Loading paragraph for detailed information on read/write head loading and unloading.)

The positioning signal is derived in the logic chassis and power supply. The signal is applied to the voice coil positioner via two flexible, insulated, metal straps the ends of which are secured to the cam mount and the carriage and bearing assembly.

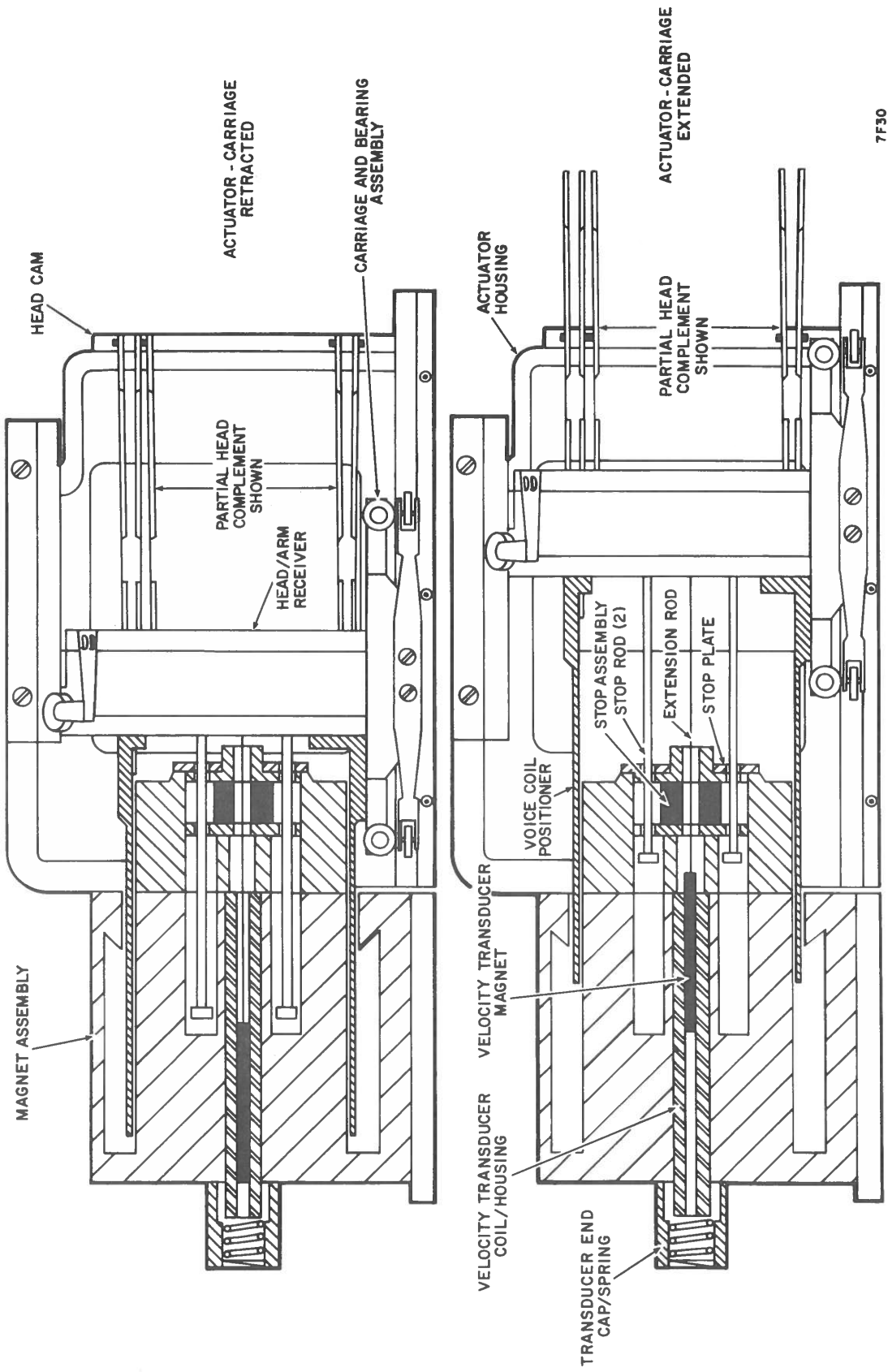

7F30

Figure 4-11. Actuator Assembly Elements

During any Seek operation the logic must be informed of the current location and travel velocity of the carriage. This information is provided by the velocity transducer in the magnet assembly and the lone track servo head installed on the head/arm receiver. The transducer is a two-piece device, one piece stationary and the other movable. Refer to the transducer and Track Servo paragraphs for a detailed description of operation.

The actuator contains a stop mechanism to limit extremes in forward and reverse movement. The stop assembly is a rubber cylinder sandwiched between two metal plates. If the carriage moves too far toward the disk pack, the stop rod heads contact the plate on the magnet-side of the rubber cylinder. If the carriage is retracted far enough away from the disk pack, the rear of the head/arm receiver contacts the stop assembly stud protruding through the stop plate.

Head Loading

The read/write heads must be loaded to the disk surfaces before exchanging data with the controller. The heads must be removed from this position (unloaded) and driven clear of the disk pack when power is removed to the unit or the disk pack velocity falls below a predetermined rpm. The actuator components involved in these operations are identified in Figure 4-12.

Head loading amounts to allowing spring pressure of the floating arm (part of head/arm assembly) to move the aerodynamically shaped head face toward the related disk surface. When the cushion of air that exists on the surface of the spinning disk is encountered, it resists any further approach by the head. Spring pressure is designed to just equal the opposing cushion pressure (function of disk pack rpm) at the required height. As a result, the head flies. However, if the spring pressure exceeds the cushion pressure (as would happen if the disk pack lost enough speed), the head will stop flying and contact the disk surface. This could cause damage to the head as well as the disk surface.

To prevent damage to the head and/or the disk pack during automatic operation, loading occurs only after the disk pack is up to speed and the heads are over the disk surfaces. For the same reason, the heads unload automatically and are retracted if the disk pack rpm drops out of tolerance. During manual operations, heads should never be loaded on a disk pack that is not rotating. Head loading is a part of the First Seek function. As power to the deck is sequenced up, the drive motor starts. This initiates disk pack rotation and a brush cycle (approximately 20 seconds).

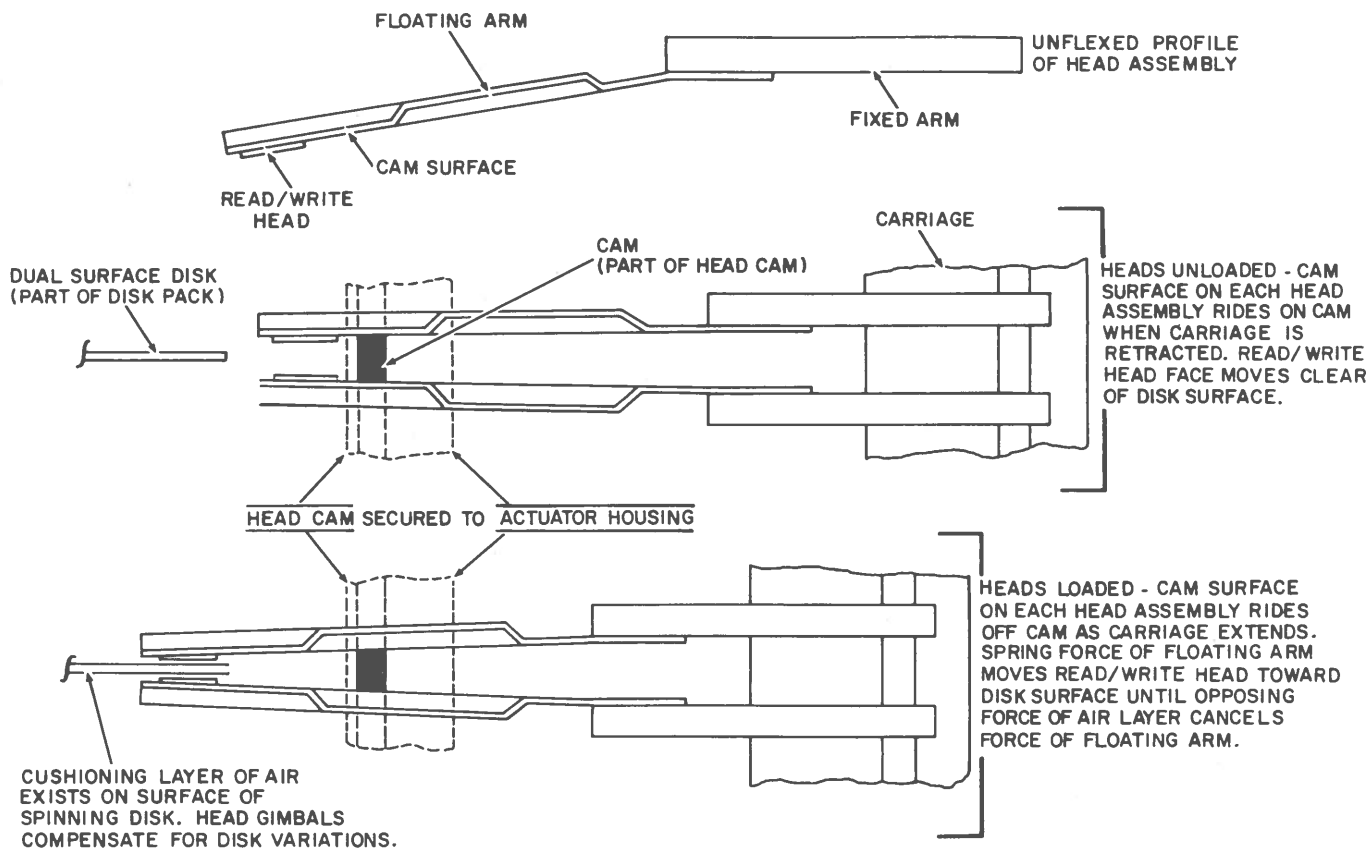

7F15

Figure 4-12. Head Loading

When the disk pack rpm reaches 2000, the power supply speed relay energizes to establish the ability to continue the operation. Upon completion of the brush cycle (brushes clear of disk pack), the logic specifies a forward seek and the carriage moves forward toward the spindle and the forward end of travel marker (part of position transducer). Head loading occurs during this forward motion.

The floating arm (Figure 4-12) is designed to maintain a constant loading force. While the heads are retracted, head cams on the actuator housing bear against the floating arm cam surfaces. The cams counter the loading force and force the heads to the unloaded position. As the carriage moves forward the cam surface rides off the cam just after the read/write head moves out over the disk surface. The loading force now moves the head face toward the air layer on the surface of the spinning disk until the opposing forces achieve a state of equilibrium.

The carriage continues toward the spindle until the forward end of travel signal occurs. Upon sensing forward end of travel, the carriage reverses and returns the now loaded heads to track 00.

The heads loaded switch status reflects the state of the read/write heads (loaded or unloaded). This status is used in the logic chassis. The switch mounts on the carriage track and is transferred by carriage motion. Whenever the carriage is fully retracted the switch state reflects the unloaded status of the heads. As the carriage moves forward during a First Seek, the switch transfers at a point within 1/4-inch forward of the retracted stop. This switch status remains unchanged until the carriage is retracted to the same position, and as such does not precisely indicate the loaded/unloaded status of the heads.

Head unloading occurs whenever power to the unit is removed or disk pack rpm drops below tolerance. Either occurrence drops a speed enable signal to the units logic. This causes the carriage to drive in reverse from its current location toward the retracted stop. (Either normal or emergency methods can be used. Refer to Power Off Sequence for additional information.) As the carriage retracts, the cam surfaces encounter the head arms and each head rides vertically away from the related disk surface. The carriage continues back to the retracted position and stops.

Head/Arm Assemblies

Twenty head/arm assemblies are mounted on the carriage. A read/write head/arm assembly consists of a read/write and erase coil package (head assembly) mounted at the end of a supporting arm structure. A track servo head/arm assembly consists of a read coil package (head assembly) mounted at the end of a supporting arm structure.

The head assembly (Figure 4-13), which includes a cable and plug, is mounted on a gimbal ring which in turn is mounted on a floating arm. This method of mounting allows the head assembly to pivot (independent of the arm) tangentially and radially relative to a data track on the disk surface. Such motion is required to compensate for possible irregularities in the disk surface.

The arm structure consists of a floating arm secured to a heavier fixed arm. The end of the fixed arm opposite the head installs in the carriage receiver. The floating arm is the mounting point for the head and is necessarily flexible so that it can respond during loading and unloading.

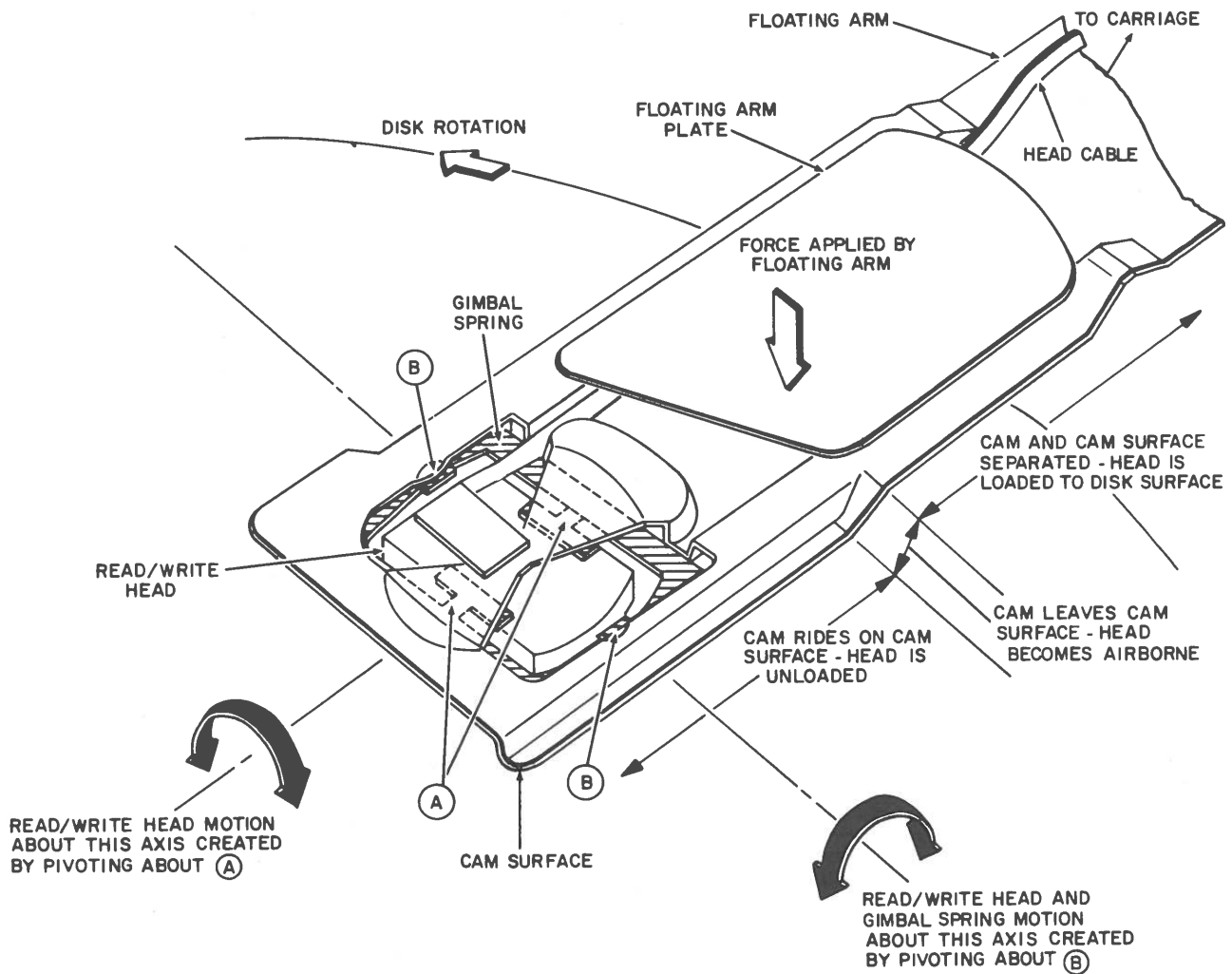

7F6

Figure 4-13. Head/Arm Assembly Motion

The freedom and mobility of the head are necessary elements to being able to function with interchangeable disk packs. During head loading each floating arm is driven off the related cam and unflexes to force a head toward the air cushion on the spinning disk surface. The force applied by the floating arm causes the heads to fly or float on the air cushion. Vertical motion by a disk surface (due to warpage or imperfection) is countered by a move in the opposite direction by the gimballed head and/or floating arm. As a result, flight height remains nearly constant.

Transducers

The deck assembly contains two transducers: index (sector) transducer and velocity transducer. These transducers provide signals that are used by the logic chassis and the controller to generally control the progression of most machine operations.

Index (Sector) Transducer

This transducer senses notches in the edge of the sector disk (large disk at the bottom of each disk pack). The transducer (Figure 4-14) consists of a light emitting diode (LED) and a photosensitive transistor. Light in the infrared range is emitted from the LED and when allowed to strike the transistor, via a notch, drives the transistor into saturation. This output is processed in the logic chassis.

Each notch on the sector disk causes the detector (Figure 4-14) to generate a 55- μ sec "1" pulse. These pulses are further processed by the DSU logic to determine if the disk pack speed is sufficient for continued operation.

Multiple sectored disk packs have two closely spaced notches called index. Unsectored disk packs have a single notch called index. These notches indicate the beginning of a revolution of the disk pack. Multiple sectored disk packs have, in addition to index, other notches equally spaced about the circumference of the sector disk. These notches are related to data organization on the disk pack.

Velocity Transducer

The velocity transducer (Figure 4-15) is a two-piece device consisting of a stationary, tubular coil/housing and a movable magnetic core.

The magnetic core is connected via the extension rod to the rear surface of the head/arm receiver. All motion on the part of the carriage is therefore duplicated by the magnetic core. As the core moves, an emf is induced in the coil. The amplitude of this emf is directly related to the velocity of the core (and carriage). The polarity of the emf is an indication of the direction of movement by the core (and carriage). The transducer output drives an operational amplifier located in the logic chassis.

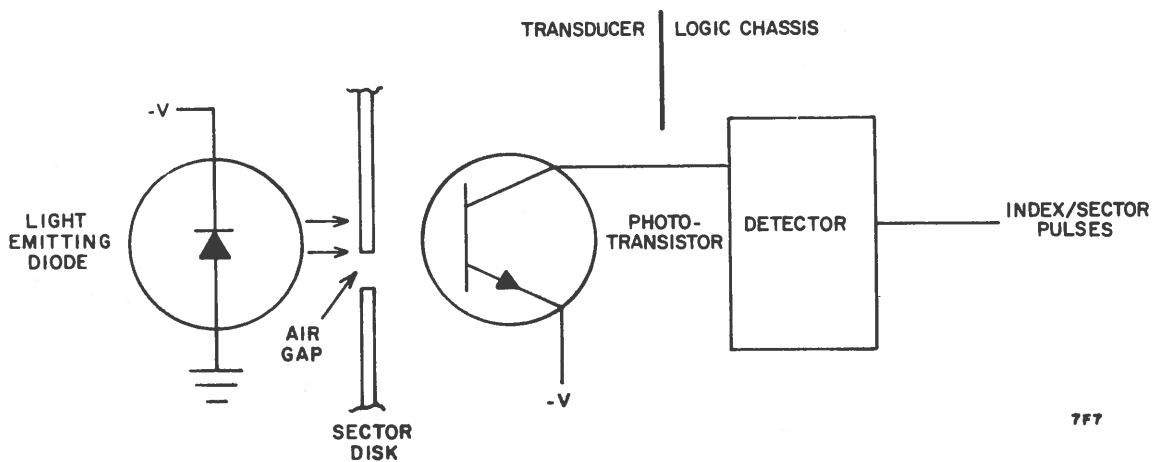

Figure 4-14. Index/Sector Detection

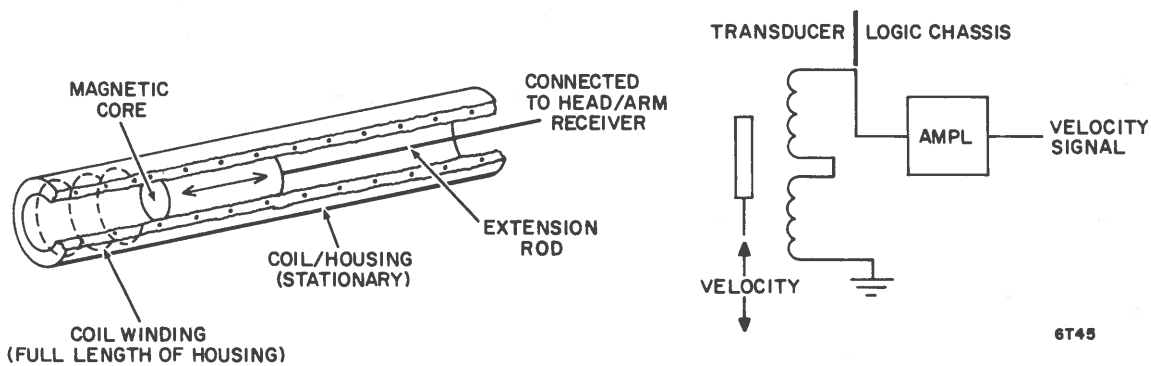

Figure 4-15. Velocity Detection

Track Servo

The elements of the track servo circuit (Figure 4-16) combine to sense the crossing of data tracks, forward end of travel, and reverse end of travel.

The track servo head is mounted with the read/write heads and functions as the sensor for the track servo circuit. The head is physically similar to the read/write heads, but contains no erase coil. Information sensed by the head is prerecorded during manufacture on the related disk surface of the disk pack. The information consists of a total of 407 servo tracks alternately recorded at 455 kHz and 500 kHz. Servo tracks

are not to be confused with data tracks or cylinders on the other 19 disk pack recording surfaces. Between the 407 servo tracks there exists 406 nulls (Figure 4-17). A data track or cylinder is located at each of these nulls on the other 19 disk surfaces.

When the read/write heads are located on a data track, the track servo head is actually between two of the prerecorded servo tracks and is reading an edge of each. The detected signal is then a mixture of the two adjacent frequencies (455 kHz and 500 kHz) and the magnitude of each frequency component is proportional to the read coil overlap of the recorded servo tracks.

The track servo head signal is amplified and the two frequency components are separated by filters and then demodulated (Figures 4-16 and 4-17). A summing amplifier combines the two components. The resulting signal is applied to zero crossing and cylinder pulse generation circuits which derive the cylinder or track pulses (Figure 4-17). The summing amplifier signal is also used during the movement over the last one-half track of any seek operation as the fine position analog signal (stopping signal). Refer to the Direct Seek paragraph for a detailed discussion of the fine position analog signal.

Circuit gain control and end of travel detection are achieved by feeding back the two filtered components to an AGC amplifier. This amplifier forms a positive, varying, composite signal that represents the track servo circuit gain. A field effect transistor (FET) functions under control of the AGC amplifier to provide a variable resistive path to ground. As circuit gain increases, the resistance to ground through the FET decreases to lower circuit gain. A decrease in circuit gain would cause the FET to present an increased resistance along the path to ground and thereby increases overall circuit gain. A detector circuit also monitors the AGC amplifier signal. The detector indicates an end of travel occurrence whenever the amplifier signal goes to zero volts.

Disk Cleaner Assembly

The disk cleaner assembly sweeps the disk pack recording surfaces free of any foreign materials. The sweep cycle occurs just before the read/write heads are loaded during the First Seek sequence

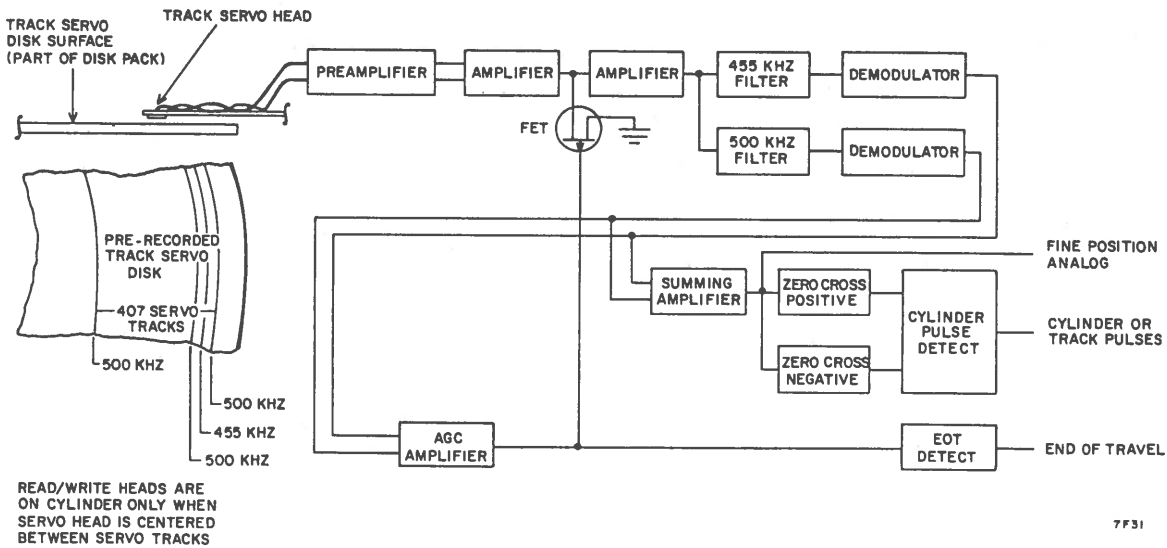

Figure 4-16. Track Servo Detection

The assembly consists of a motor, 10 comb-mounted brushes, a reset switch, motor to comb linkage, and a mounting base. The base mounts on the deck assembly and the brushes are pivot mounted on the base. Pivoting of the brushes is controlled by the motor, the linkage, and the switch. The motor is energized during the Power-On sequence and starts a 20-second (approximate) cycle. As the cycle proceeds, the brushes sweep toward the spindle until the linkage causes a reversal in direction. As the brushes return to the original position (clear of disk pack), the reset switch is encountered and transfers to disable power to the motor.

The shaft on which the brushes are installed is driven via a ball-slot detent mechanism. If power is dropped or lost during the brush cycle, the operator can override the detent and rotate the brushes clear of the disk pack so that the disk pack can be removed from the spindle. The brush cycle during the next Power-On sequence will be an incomplete cycle as the brushes automatically reset themselves. Subsequent cycles will be normal.

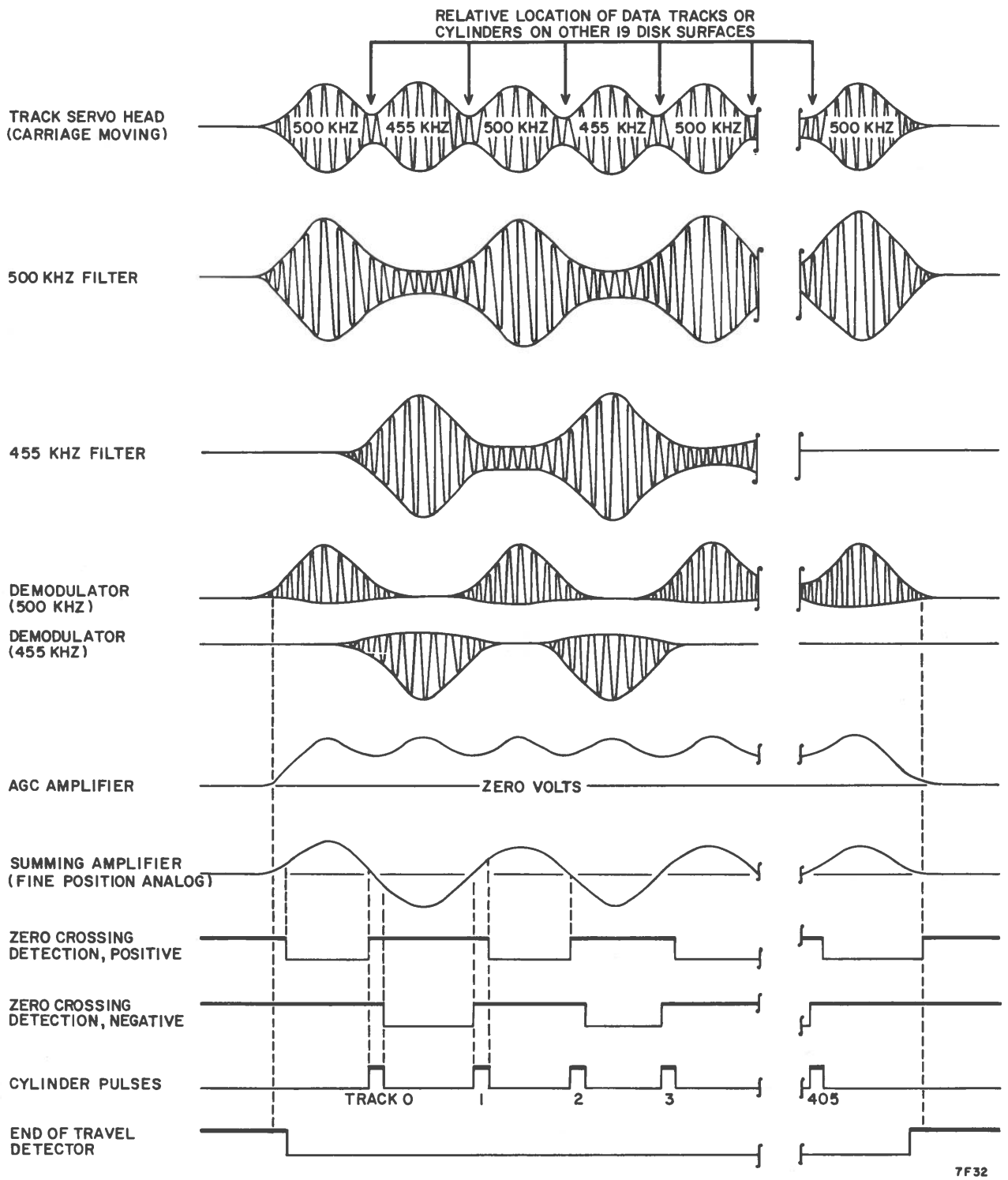

Figure 4-17. Track and EOT Pulses

BLOWER SYSTEM

The blower system (Figure 4-18) provides positive pressure at the center of a disk pack mounted on the spindle of a deck assembly. The presence of this elevated pressure results in an outward dispersion of air over each disk surface. This air flow greatly reduces possible contamination and resulting damage to the disk surfaces and the read/write heads. The system also provides cooling air to the logic chassis and power supply assembly.

The system consists of a motor driven impeller that draws air in through the primary filter in the bottom of the unit. A portion of this air is forced through an absolute filter and related ducts upward to a chamber in the bottom of the deck and then to the spindle. The remainder of the air is distributed directly from the blower housing (no additional filtering) to ducts leading to the power supply and the logic chassis.

Power to the blower drive motor is controlled by the circuit breaker in the filter box.

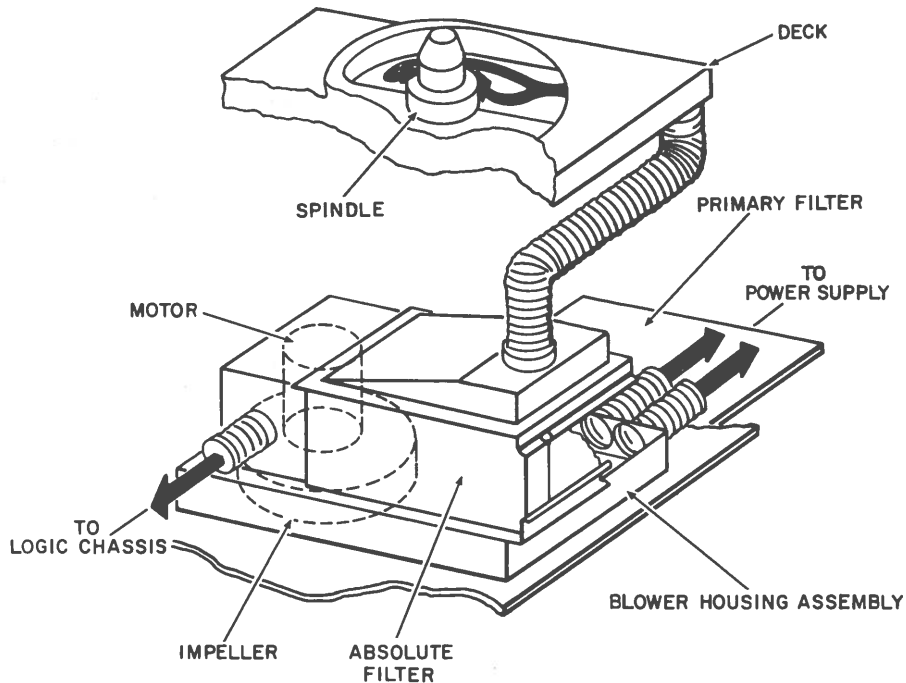

7F13

Figure 4-18. Blower System

DISK PACK

The disk pack is the recording medium for the DSU. The disk pack consists of 11 14-inch, magnetic oxide coated disks center-mounted on a hub. The recording surface of each disk is coated with a layer (0.0002-inch) of magnetic iron oxide and related binders and adhesives.

The 406 recording tracks are located in a 2-inch band near the outer edge of the disk. Track 405 has a diameter of approximately 9 inches, while the diameter of track 00 is about 13 inches. The tracks are spaced 0.005 inch apart.

The top and bottom disk surfaces are covered by protective non-recording disks. The bottom protective disk is called the sector disk. This disk contains notches that are sensed by the index transducer. The pulse outputs of the transducer are used to determine disk pack rpm and to detect organizational segments of the disk pack.

The lower hub of the disk pack contains a replaceable filter. This filter removes particles from the air supplied by the blower. Keeping positive air pressure at the center of the disks, as the blower does, reduces the possibility of damage caused by ingested dust.

The disk pack has a two-piece container assembly. The bottom cover can be removed simply by grasping and rotating the center hub. The top cover is designed so that it can be removed only by installing the disk pack on the deck spindle assembly. The disk pack can be removed from the spindle only by using the top cover (see Section 2). This design protects the disk pack from physical damage and greatly reduces the possibility of contamination of the disk pack recording surfaces.

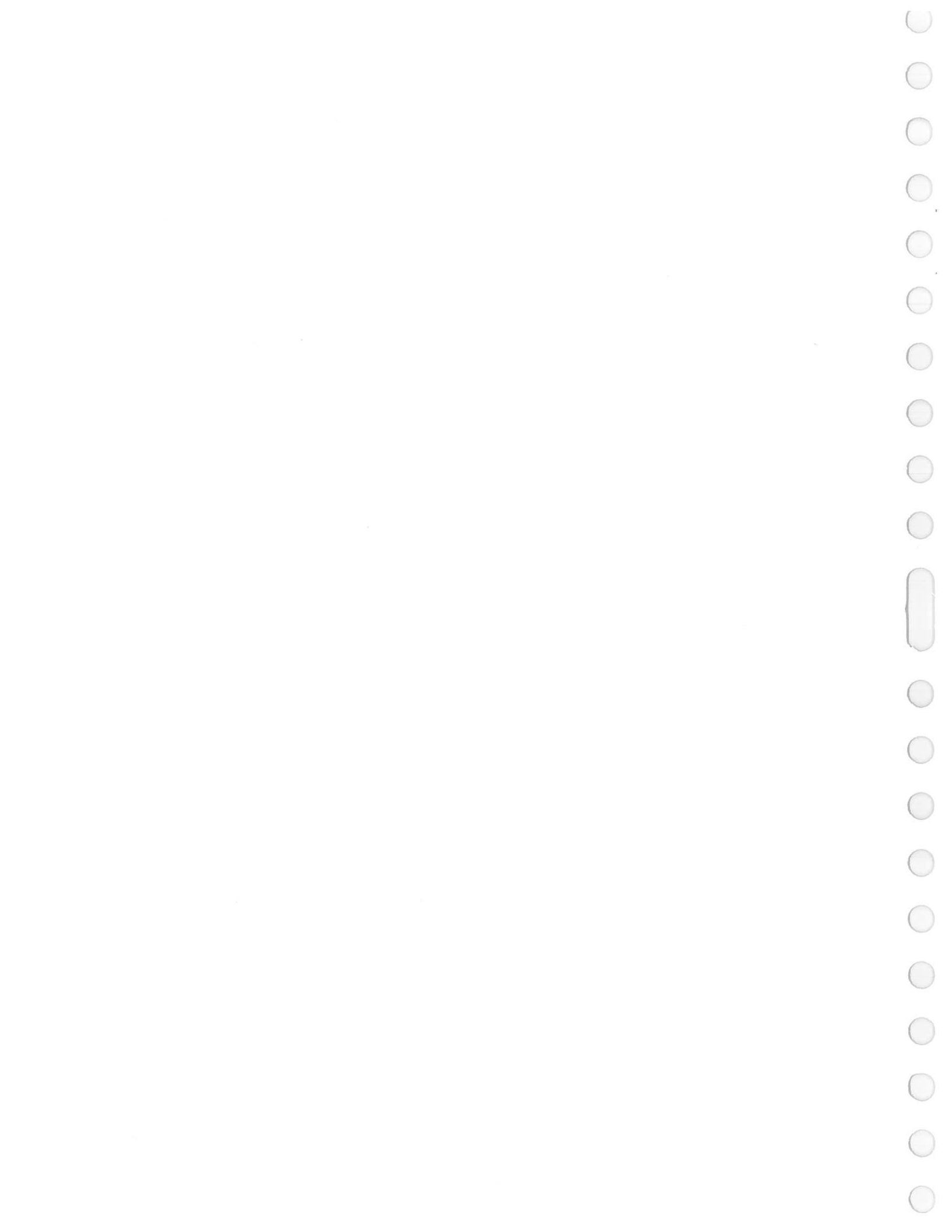

SECTION 5

DIAGRAMS

Information for this section is contained in BR2A5
Disk Storage Unit, Pub. No. 70614700.

SECTION 6

MAINTENANCE

MAINTENANCE

This section contains the instructions required to maintain a DSU. The information is provided in the form of preventive maintenance, corrective maintenance and troubleshooting.

MAINTENANCE TOOLS

The special tools required to maintain a DSU are listed below:

<u>Tool</u>	<u>Control Data Part Number</u>
AC/DC Volt/Ohmmeter, Ballantine Labs Inc, Model 345 (or equivalent)	
Belt Tension Gage	84267100
CE Disk Pack	89259000
Card Extender, Half-size	54099700
Card Extender, Full-size	54109700
Card Puller	84146900
Carriage Alignment Ring	87351000
Carriage Alignment Arm	87371200
Feeler Gages	
Head Adjustment Tool	87371100
Multimeter, Simpson 260 (or equivalent)	
Oscilloscoper, dual-trace, Tektronix 546 with Type CA preamplifier (or equivalent)	

<u>Tool</u>	<u>Control Data Part Number</u>
Push-Pull Gage	12210797
Precision Calibrated Pack Tool	87357000
Tester Card, Access	54116100
Tester Card, Read/Write	54113701
Torque Screwdriver	12218425
Torque Screwdriver Bit	87016703

MAINTENANCE MATERIALS

The materials used in the procedures of this section are listed below:

<u>Material</u>	<u>Source</u>
Gauze, Lint-Free	Control Data 12209713
Isopropyl Alcohol	Control Date 12210956
Loctite, Grade C	Loctite Corporation
Loctite Primer, Grade N	Loctite Corporation
Oil (1/2-pint container)	Control Data 12208888
Plastic Spatulas	Commercially available
Tape, Adhesive	Commercially available

PREVENTIVE MAINTENANCE

GENERAL

Performance of the DSU is dependent upon the proper and timely execution of a preventive maintenance routine. Such a routine is provided by the Preventive Maintenance Index following.

The index consists of five levels based on a calendar period or hours of operation (whichever comes first). The power supply elapsed time meter keeps a cumulative record of hours of operation. Perform preventive maintenance in accordance with the indication of this meter. The Preventive Maintenance Procedure column lists the title of the paragraph containing the required instructions.

PREVENTIVE MAINTENANCE INDEX

*Level					Preventive Maintenance Procedure	Estimated Procedure Time (Minutes)
1	2	3	4	5		
		X			Inspect actuator assembly	2
		X			Clean front cover glass	1
		X			Change primary filter**	5
		X			Check power supply outputs	2
			X		Inspect and clean read/write and servo heads	10
			X		Clean shroud and spindle	1
			X		Clean pack cleaning brushes	2
			X		Clean and lubricate lockshaft	2
				X	Replace absolute filter**	20

- *Level 1 - Weekly or 150 hours (no preventive maintenance scheduled)
- Level 2 - Monthly or 500 hours (no preventive maintenance scheduled)
- Level 3 - Quarterly or 1,500 hours
- Level 4 - Semiannually or 3,000 hours
- Level 5 - Annually or 6,000 hours

**Intervals are maximum times. Preventive maintenance may be required more frequently depending on dust contamination level of operating area.

INSPECT ACTUATOR ASSEMBLY

1. Raise cabinet top cover.
2. Inspect entire actuator for presence of dust and other foreign materials.
Pay particular attention to following areas:
 - a. Circular cutout in face of magnet assembly (receives voice coil).
 - b. Rail surfaces (particularly the horizontal surfaces) of carriage track on which carriage and bearing assembly travels.
3. Use lint-free gauze dampened (not soaked) with isopropyl alcohol to remove deposits or attracted particles.

CLEAN FRONT COVER GLASS

Use lint-free gauze dampened (not soaked) with isopropyl alcohol to remove smudges and deposits from the glass in the front cover.

CHANGE PRIMARY FILTER

1. Open cabinet front panel.
2. Set filter box circuit breaker to OFF.
3. Remove primary filter (Figure 6-1).
4. Install replacement filter (P/N 92682017).

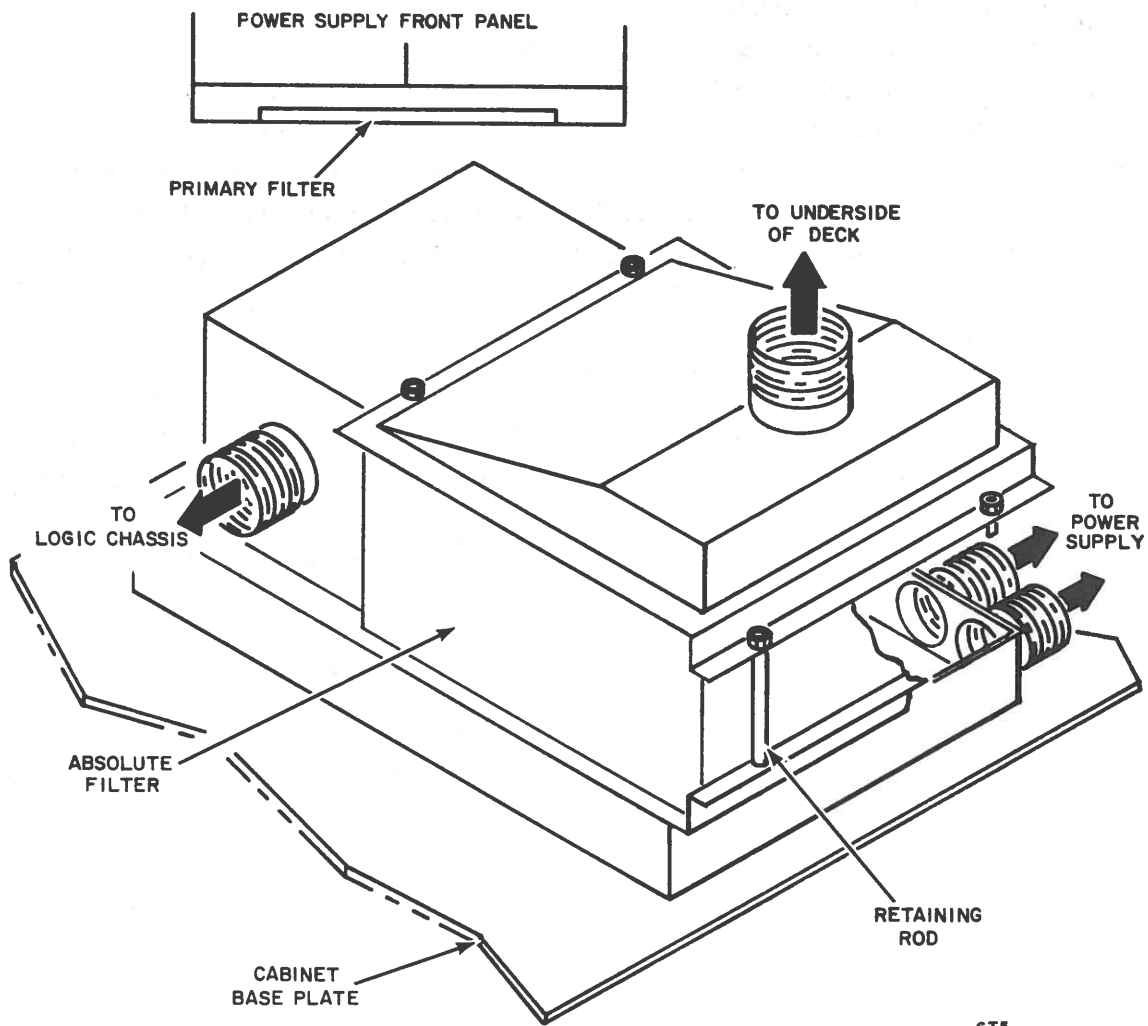

Figure 6-1. Cabinet Filters

6T5

CHECK POWER SUPPLY OUTPUTS

1. Open cabinet rear door.
2. Start spindle motor and allow read/write heads to load.

NOTE

In the following procedure it is necessary to command carriage motion. These commands may be derived by either suitable software and the central processor or the access tester card (P/N 54116100) installed in logic chassis (location C30). When a command is derived from the access tester card, set the unit ON LINE/OFF LINE switch to OFF LINE.

3. Command a 140-track repeat seek (140 tracks forward and 140 tracks reverse continuously) from track 0.
4. Use an AC/DC volt/ohmmeter to measure output voltages at corresponding test jacks on logic chassis maintenance panel.

- a. Measure +40 volts.

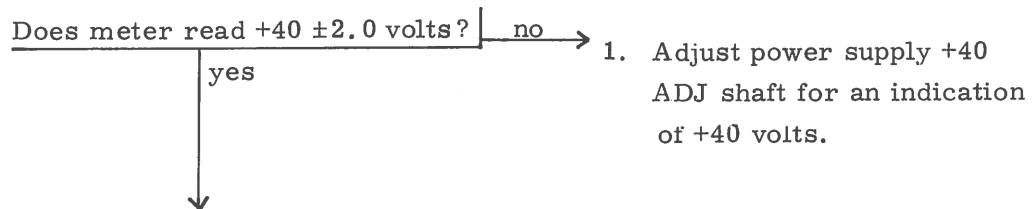

- b. Measure +20 volts.

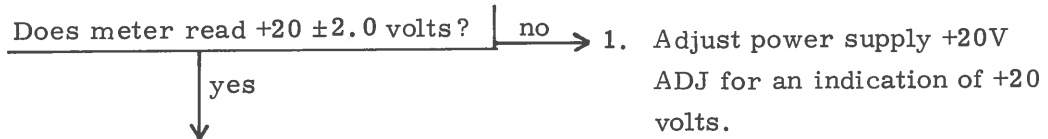

- c. Measure -20 volts.

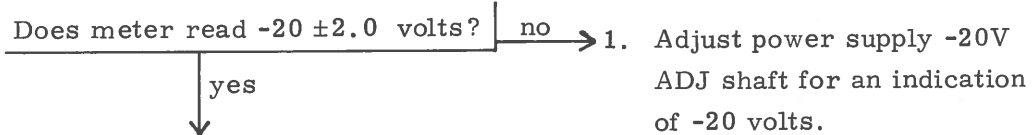

- d. Measure +5.1 volts.

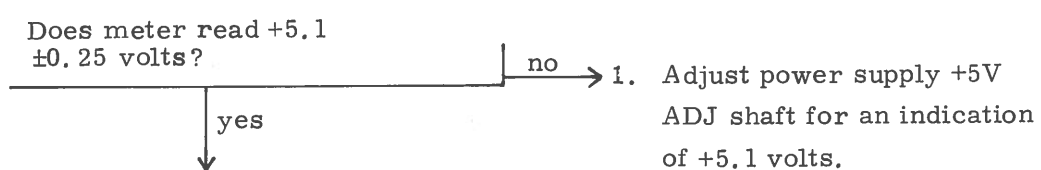

(Procedure Continued)

e. Measure -5.1 volts.

Does meter read -5.1 ± 0.25 volts?

no

1. Adjust power supply -5V ADJ shaft for an indication of -5.1 volts.

yes

Procedure completed.

INSPECT AND CLEAN READ/WRITE AND SERVO HEADS

1. Stop spindle motor and open cabinet top cover.

NOTE

Use a suitably bright and directional light during following steps.

2. Inspect heads as follows (carriage must remain fully retracted):

CAUTION

Do not smoke while inspecting. Use extreme care not to damage heads with dental mirror. Gimbal spring (holds head on end of floating arm) is most liable to be damaged. If gimbal spring is permanently bent, entire head/arm assembly must be replaced.

- a. Use dental mirror to inspect face of each head for reddish-brown oxide deposits. Clean a head only if deposits exist (see step 3).
- b. If scratches are found, refer to Maintenance Aids section, Pub. No. 70614700, for head replacement criteria.

3. Clean heads (only if required) as follows:

CAUTION

Do not smoke while cleaning. Do not touch a head face with fingers. When cleaning or buffing, always move tongue depressor perpendicular to length of head/arm assembly. Do not leave residue or lint on head faces. Trapped residual particles can result in the loss of a head and/or a scored disk.

- a. If oxide deposits were found, use lint-free gauze on a tongue depressor to lightly dry-buff the head face. If deposits are removed, cleaning is completed.

- b. If oxide deposits were not removed, dampen (do not soak) gauze with isopropyl alcohol and wipe head face. If deposits are removed, use dry gauze to lightly buff head face.
- c. If oxide deposits were not removed in step b, refer to Maintenance section. Remove head/arm assembly from carriage, and repeat step b.
- d. If oxide deposits still remain, install a new head/arm assembly.

CLEAN SHROUD AND SPINDLE

- 1. Stop spindle motor.

CAUTION

When top cover of unit is open, care must be used to keep any disk pack at least three inches away from any part of the magnet assembly. Erasure of data can occur.

- 2. Open top cover.
- 3. Remove disk pack. Avoid contact with index transducer.
- 4. Clean shroud with a lint-free gauze that is slightly dampened with isopropyl alcohol. Wipe shroud to remove all dirt and smudges. Thoroughly wipe spindle surface.
- 5. After cleaning shroud, use a wad of adhesive-type tape and pick up any particles that were not picked up with gauze. Make certain that all particles are removed from interior of shroud.

CHECK PACK CLEANING BRUSHES

- 1. Stop spindle motor.
- 2. Open top cover.
- 3. Check brushes for presence of dust or excessive wear.

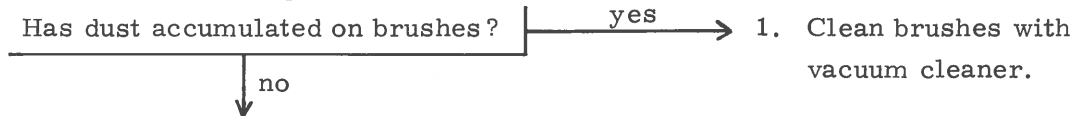

(Procedure Continued)

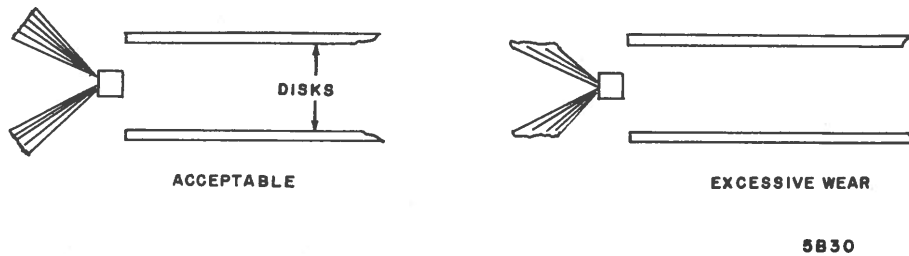
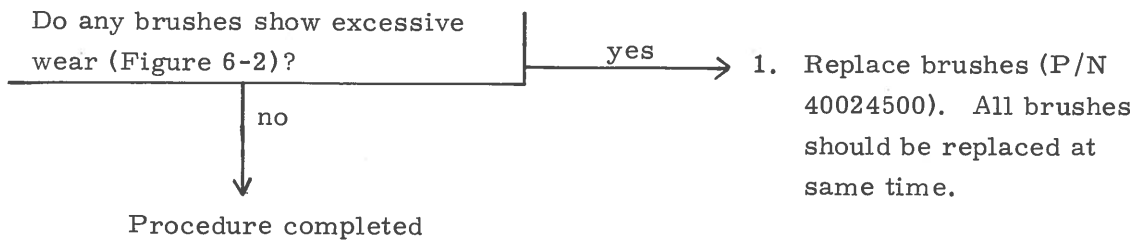

Figure 6-2. Pack Cleaning Brushes

CLEAN AND LUBRICATE LOCKSHAFT

1. Stop spindle motor.
2. Remove disk pack.
3. Open top cover.
4. Use lint-free gauze and a brush or sharp instrument to clean lockshaft threads on top end of spindle.
5. Apply a thin coat of oil (P/N 95020400) to threads.

REPLACE ABSOLUTE FILTER

1. Open cabinet rear panel and set filter box circuit breaker to OFF.
2. Swing logic chassis out.
3. Refer to Figure 6-1 and loosen four retaining rods securing filter.
4. Raise metal chamber on top of filter and slide filter clear of cabinet.
5. Install replacement filter (P/N 94301100) by reversing above steps.
6. Make certain that all seams (gasket foam) are tight and will not allow air to bypass filter.

CORRECTIVE MAINTENANCE

The maintenance procedures for the DSU are provided on the basis of the Subassemblies of the unit. Detailed procedures (Check, Adjustment, Removal and/or Replacement) are provided as subparagraphs to the Subassembly heading.

CAUTION

Care must be used when handling a disk pack around a unit with its top cover open. Erasure of data on the pack will occur if the pack gets closer than three inches to the magnet assembly.

CAUTION

An access tester card and a R/W tester card can be used during various maintenance procedures. The logic chassis maintenance panel DC switch must be set to OFF before installing or removing these or any other cards in the logic chassis or on the deck. Additionally, the $\pm 20V$ circuit breakers must be set to OFF before installing or removing a transmitter or receiver card from the logic chassis.

It is recommended that maintenance personnel read the entire procedure prior to performing the instructions of the procedure. Procedures requiring oscilloscope connections to be made in the logic chassis assume that the front and/or rear covers of the chassis have been removed.

CDC PACK CLEANING PROCEDURE

1. Stop spindle motor.
2. Open cabinet front cover.
3. Open interior cover.
4. Remove disk pack from spindle.
5. Install disk pack to be cleaned on spindle.

NOTE

Use of a suitably bright and directional light during following steps is recommended. When manually rotating disk pack in following steps, override spindle lock ratchet by allowing open front cover to rest on shoulder.

6. Slowly revolve disk while observing each disk surface. If severe scratches (oxide coating removed from disk surface to point of baring substrate) are found, refer to Maintenance Aids, Pub. No. 70614700. Refer to that section for disk pack replacement criteria.

7. Wrap a piece of lint-free gauze around a plastic spatula (or a tongue depressor) and dampen (do not soak) with isopropyl alcohol.
8. Insert the spatula into disk pack until tip contacts hub of disk pack.

NOTE

Apply moderate and constant pressure to disk surface with spatula during following step.

9. Slowly rotate disk pack while very slowly withdrawing tip of spatula. Continue withdrawing spatula until tip is clear of disk pack circumference.
10. Repeat steps 7, 8, and 9 for a disk surface until gauze comes away clean from disk surface.
11. Wrap a clean, dry piece of gauze on spatula and repeat steps 8 and 9 to remove residue released by alcohol.
12. Repeat steps 7 through 11 for each remaining recording surface of disk pack.
13. Dampen a piece of gauze with isopropyl alcohol and wipe clean the exposed top surface of disk pack. Dry the surface.
14. Use alcohol dampened gauze to clean both pieces of disk pack container.
15. Wipe container dry.
16. Remove disk pack from spindle (do not install bottom half of container). Invert container and inspect nylon mesh filter surrounding lower hub of disk pack. If filter is discolored (normally white), replace as follows:
 - a. Release O-ring securing lower rim of filter.
 - b. Remove dirty filter.
 - c. Insert new filter (Control Data P/N 40050500) in cavity and secure with original O-ring.
17. Install bottom of disk pack container. Set pack and container aside.

CAUTION

Bearing damage may occur if alcohol runs into spindle.

18. Clean spindle cone of DSU thoroughly with alcohol dampened gauze.
19. Replace front shroud panel.

READ/WRITE AND SERVO HEADS

Check Head/Arm/Adjustment

1. Stop spindle motor and set DC switch to OFF.
2. Open cabinet top cover.

CAUTION

Failure to turn ± 36 V circuit breakers off may cause uncontrolled head loading and unloading operations.

3. Set ± 36 V circuit breakers to OFF.
4. Remove SPL card at location E04 and head cable clamp assembly.

CAUTION

The CE disk pack contains specially recorded tracks of data. Extreme care must be taken so that this data is not modified.

5. Close top cover and open front cover. Install CE disk pack (P/N 89259000).
Avoid contacting index transducer.
6. Set DC switch to ON. Set ON LINE/OFF LINE switch to OFF LINE.

NOTE

The disk pack must be temperature stabilized before continuing the procedure. Pack must be stored in same environment as DSU for the 60-minute period immediately preceding performance of this procedure.

7. Close top and front covers of unit. Start spindle motor and allow brush cycle to end. Manually position carriage forward to load read/write heads.
Allow heads to remain over disk surfaces. Operate in this configuration for 30 minutes before going to next step.
8. Open top cover.
9. Connect oscilloscope external trigger to test point C (Index) of card at location A02.
10. Connect oscilloscope channels A and B to test points G and F of SPL card at location E05. Ground oscilloscope at test point A of same card.
11. Disconnect servo head cable plug from edge of card at E03 (Figure 6-3).
12. Disconnect head cable plug for any read/write head and reconnect the servo head cable plug in its place.
13. Select the read/write head disconnected in step 12 by grounding (at test point A or Z of card at E03) similarly numbered test point located as follows:

<u>Head Test Point No.</u>	<u>Card Location</u>	<u>Head Test Point No.</u>	<u>Card Location</u>
0, 2, 4, 6, 8, 10, 12, 14, 16, and 18	E01	1, 3, 5, 7, 9, 11, 13, 15, and 17	E02

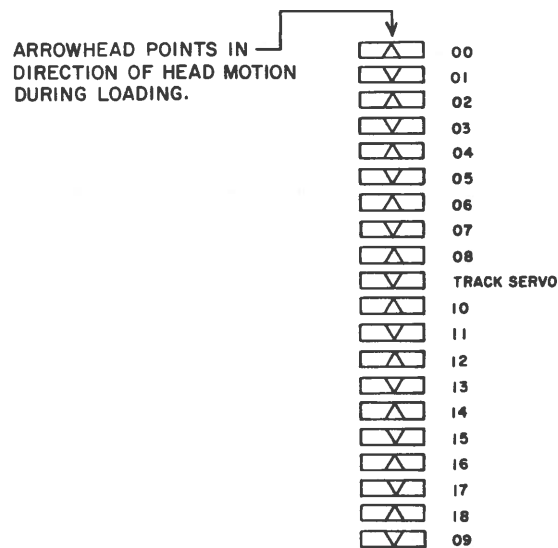

7F8

Figure 6-3. Head Identification

NOTE

Since one revolution of disk pack equals 25ms, the oscilloscope horizontal time base must be placed in the uncalibrated position in order to achieve the waveforms of Figure 6-4.

14. Manually position carriage to track 146.
15. Adjust oscilloscope sweep so that three cross-over points (nulls) span exactly 10 centimeters (Figure 6-4).
16. Carefully move carriage to achieve an oscilloscope display that is as close as possible to Figure 6-4, part C. While maintaining the display, press lightly downward on the lower mechanical connection between the voice coil and carriage and tighten the carriage lock to lock the carriage at track 146. (Lock is located to right of actuator when standing behind magnet assembly.) Record observed cross-over point relative to center vertical graticule.
17. Disconnect servo head cable plug (connected in step 12) and reconnect it to edge of card at E03.

18. Connect the disconnected read/write head cable plug.
19. Select head to be adjusted (Figure 6-3) by grounding (at test point A or Z of card at E03) similarly numbered test point located as follows:

<u>Head/Test Point No.</u>	<u>Card Location</u>	<u>Head/Test Point No.</u>	<u>Card Location</u>
0, 2, 4, 6, 8, 10, 12, 14, 16, and 18	E01	1, 3, 4, 5, 7, 9, 11, 13, 15, and 17	E02

20. Adjust oscilloscope sweep so that three cross-over points (nulls) span exactly 10 centimeters (Figure 6-4).

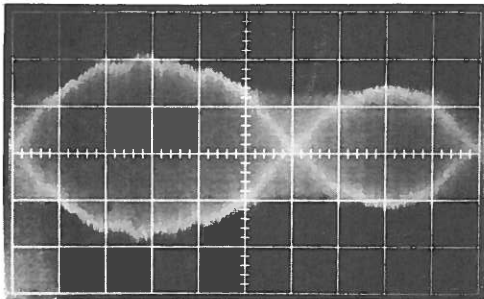

A HEAD POSITIONED TOO FAR FROM SPINDLE

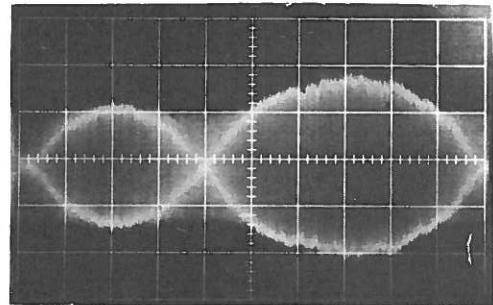

B HEAD POSITIONED TOO CLOSE TO SPINDLE

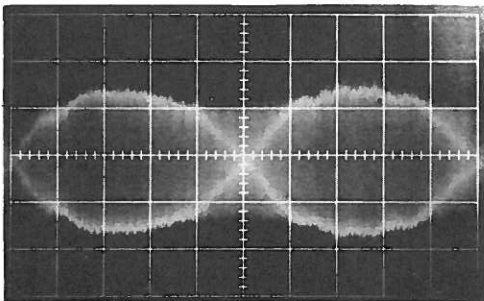

C HEADS ON TRACK 146

ALL TRACES
 HOR-2MS/CM, UNCAL.
 VERT- μ 0.5V/CM

7F28

Figure 6-4. Head Adjustment Trace

NOTE

If all the read/write heads are to be adjusted, the center cross-over points relative to the value recorded in step 16 should be within ± 0.2 cm of each other (in steps 21 and 23).

21. Record position of center cross-over point relative to center vertical graticule line. It must be within ± 1.0 cm of value recorded in step 16.
22. If recorded value meets requirement, go to step 24.
23. Perform adjustment as follows:
 - a. Refer to Figure 6-5 and place slot in end of head adjustment tool (P/N 87371100) over head/arm assembly so that tips of tool straddle carriage ridge and tool pin engages head/arm notch.

NOTE

Very little tool motion is required to make the adjustment. The clamp nuts securing the head/arm clamps need not be loosened.

- b. Moving tool laterally (parallel to head/arm length), reposition head/arm until center cross-over point displayed on oscilloscope is within ± 1.0 cm of value recorded in step 16.
24. Repeat steps 19 through 22 for read/write heads immediately above and below head just adjusted.
25. Repeat steps 19 through 22 for three randomly selected heads. If any one of the three requires adjustment, check the adjustment of all heads.
26. Disengage carriage lock to free carriage. Manually move carriage to retracted position.
27. Stop spindle motor. Remove CE disk pack. Avoid contact with index transducer.
28. Disconnect oscilloscope.
29. Set DC switch to OFF. Install card and cable clamp assembly removed in step 4.

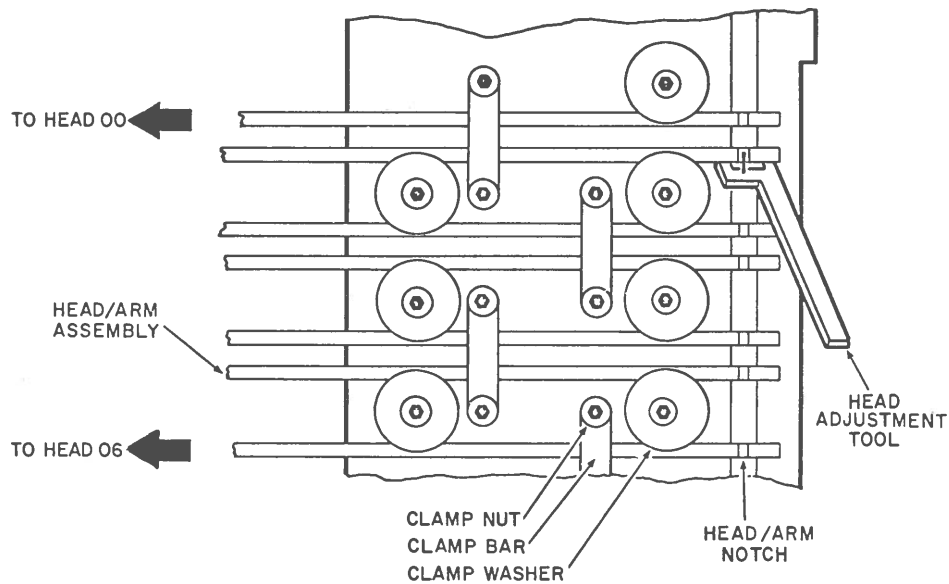

7F9

Figure 6-5. Head/Arm Assembly Adjustment

Head/Arm Removal and Replacement

1. Stop spindle motor.
2. Set DC switch to OFF.
3. Open cabinet top cover.
4. Remove disk pack. Avoid contact with index transducer.
5. Refer to Figure 6-6 to determine location of faulty head/arm assembly.
6. Remove head cable clamp assembly and disconnect head plug at card E01 or E02 as applicable.
7. Remove clamp nuts securing clamp bar and washer(s) against faulty head/arm assembly (Figure 6-6 and Table 6-1) using tools 12218425 and 87016703. Set nuts, bars, and washer(s) aside.

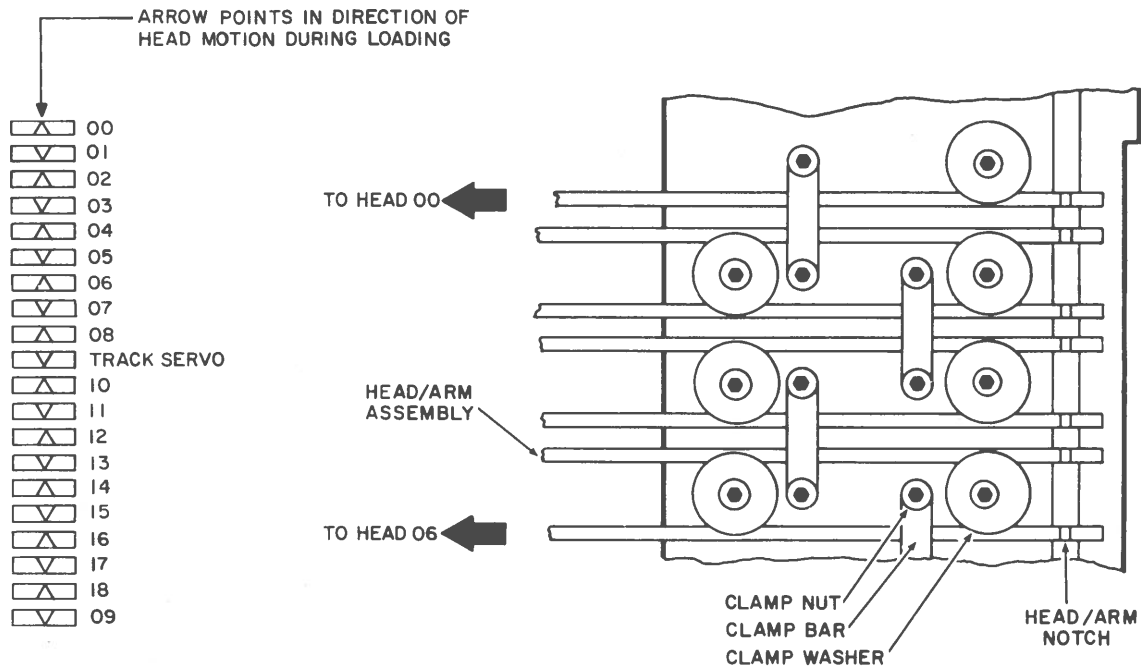

7F10

Figure 6-6. Head/Arm Replacement

CAUTION

Observe the following cautionary instructions during the remainder of this procedure (Figure 6-7).

1. Do not touch the read/write head face. Damage to the related gimbals may result.
 2. Use only the minimum force required when overriding the assemblies tendency to unflex. Unnecessary force can make the assembly unuseable.
 3. Hold both ends of the assembly securely at all times. If the assembly is allowed to unflex, it may cause damage to itself and/or an adjacent assembly.
 4. Keep all contact with adjacent heads to minimum. This will save realignment time later.
8. Grasp the carriage end of the head/arm assembly (Figure 6-7) between the thumb and forefinger.

9. Grasp the other end (avoid read/write head face) between thumb and forefinger of other hand and move assembly away (up or down) from related cam surface.
10. Keep assembly off cam while working carriage end of assembly free. When it is free, hold both ends securely and keep the assembly straight while withdrawing it from the carriage and the cam mount. Set faulty head aside.
11. Start the carriage end of the replacement assembly toward the carriage. Keep contact with the assemblies above and below to a minimum. When the end starts to enter the carriage notch, simultaneously raise head cam surface onto cam while applying pressure at the flex point to straighten the head. With pressure still applied at the flex point engage the carriage end of the assembly with receiving slot.

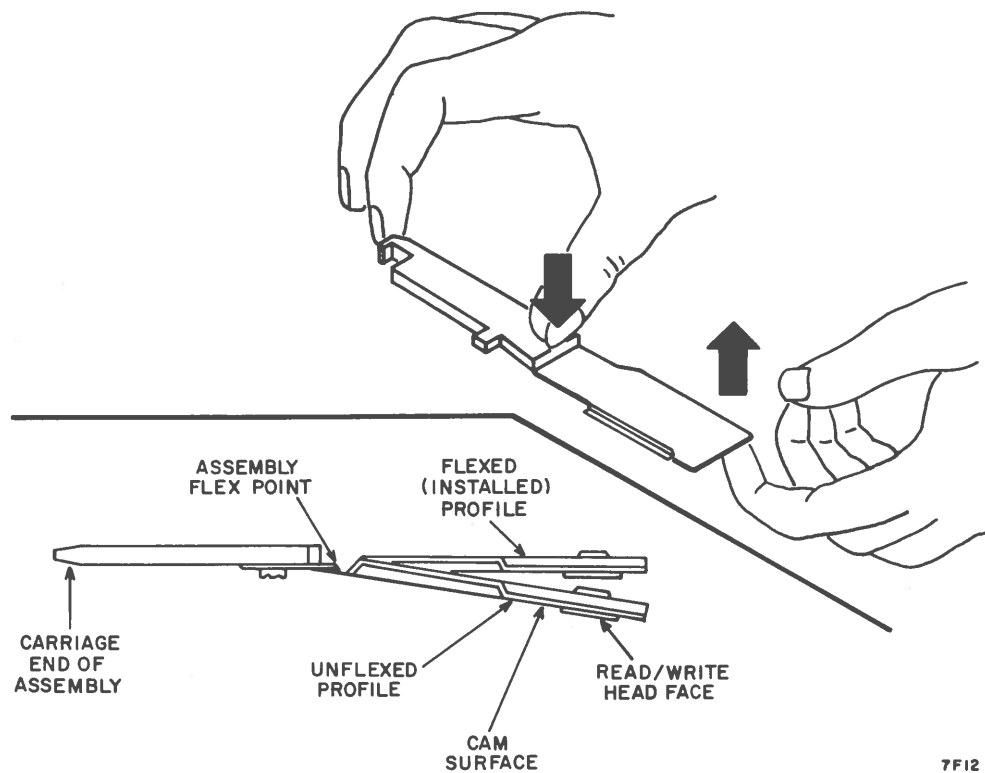

Figure 6-7. Head/Arm Installation or Removal

12. Visually align free end of assembly with those assemblies above and below.
13. Connect head plug at card E01 or E02 as applicable.

14. Inspect replaced assembly. Make certain that head cable is oriented similarly to other adjacent cables.

NOTE

Make certain that clamp bar is contacting the outer edge of both head/arm assemblies before tightening the clamp nuts.

15. Assemble clamp bar and washer(s) over head (Figure 6-6). Secure clamp bar, washer(s), and head with clamp nuts. Use tools 12218425 and 87016703 to tighten clamp nuts to 6.0 ±0.5 in. -lbs.
16. Replace cable clamp assembly.
17. Perform Head/Arm Adjustment procedure on replaced head and heads immediately above and below it.
18. Perform Adjacent Track Erase Check procedure on replaced head.
19. Perform Index to Burst Check and Adjustment procedure.

TABLE 6-1. READ/WRITE HEAD REPLACEMENT DATA

Read/Write Head Identification No. (See Figure 6-6)	Read/Write Head Replacement Part No.
00, 02, 04, 06, 08, 10, 12, 14, 16, 18	70590200
01, 03, 05, 07, 09, 11, 13, 15, 17	70590201
Servo head	70590101

Adjacent Track Erase Check

It is necessary to perform this check only on a read/write head that has been replaced.

NOTE

In the following procedure it is necessary to position heads to specific track locations. These commands may be derived by either suitable software and the central processor or the access tester card (P/N 54116100) installed in logic chassis (location C30). The procedure also requires that data be written on a disk pack. Write operation may be performed with either suitable software and the central processor or the R/W tester card (P/N 54113701) installed in logic chassis (location C23). Whenever a command is derived from a tester card, set the unit ON LINE/OFF LINE switch to OFF LINE.

1. Position the carriage to track 404.
2. Write a data pattern of all ones with the read/write head that was replaced.
3. Open cabinet top cover.
4. Connect channels of oscilloscope (to add and invert channel B) to test point F and G of SPL card at location E05 for all heads. Ground oscilloscope at test point R or Y of same card.
5. Connect oscilloscope external trigger to test point C of card at location A02.
6. Select head (of step 2) for a Read operation. Observe oscilloscope trace amplitude. Record amplitude.
7. Position carriage to track 403. Write data pattern of all ones with head from step 2.
8. Position carriage to track 405. Write data pattern of all ones with head from step 2.
9. Position carriage to track 404.
10. Select the head for Read operation. Observe oscilloscope trace amplitude. Amplitude must be at least 85 percent of the amplitude recorded in step 6.
11. If the read/write head fails any of the above requirements, replace it.

Tuned Amplifier Check and Adjustment

NOTE

In the following procedure it is necessary to position heads to specific track locations. These commands may be derived by either suitable software and the central processor or by the access tester card (P/N 54116100) installed in logic chassis (location C30). The procedure also requires that data be written on a disk pack. Write operation may be performed with either suitable software and the central processor or the Read/Write tester card (P/N 54113701) installed in logic chassis location C21. Whenever a command is derived from a tester card, set the unit ON LINE/OFF LINE switch to OFF LINE.

1. Press (to illuminate) START button and allow unit to reach speed.
2. Position carriage to track 405.
3. Write a pattern of ones with each head.
4. Open cabinet top cover.
5. Connect oscilloscope channels A and B to test points B and C (respectively) of card at location A16.
6. Set both scope MODE switches to ADD. Invert channel B.
7. Connect channel B external trigger to test point "C" of card at location A02; connect channel A external trigger to test point "C" of card at location A16.
8. Set oscilloscope horizontal display so that channel A is delayed by channel B.
9. Select any head (via central processor or Read/Write tester) and read track 405.
10. Make proper oscilloscope adjustments to achieve waveform in Figure 6-8.

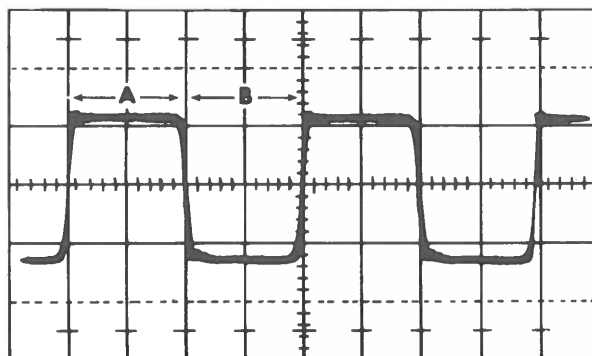

PERIOD A EQUALS B TO
WITHIN ± 5 PERCENT

HOR $0.2 \mu\text{SEC}/\text{CM}$
VERT $1 \text{ V}/\text{CM}$

5965

Figure 6-8. Symmetry Adjustment

11. Displayed pulses must be of equal duration within accuracy displayed in Figure 6-8. If they are not, adjust upper variable resistor (500 ohm) on edge of card at location A16 to achieve requirement. If adjustment fails, check that data was actually written before replacing card at location A16.
12. Disconnect channel B probe at test point "C" of card at location A16.
13. Set channel B to normal.
14. Set channel mode switch to channel 1.
15. Connect channel A probe to test point "D" of card at location A16.
16. Make oscilloscope adjustments to achieve waveform in Figure 6-9.

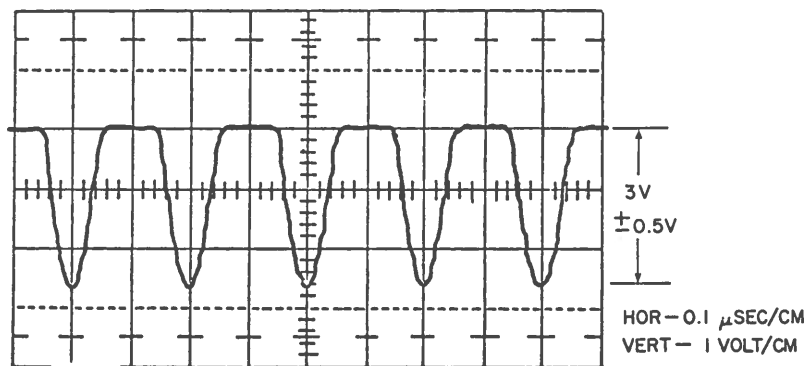

7N9A

Figure 6-9. Read Oscillator Output Waveform

17. Adjust variable capacitor on edge of card at location A16 to achieve maximum waveform voltage. Note that maximum voltage is maintained through several turns during adjustment of the capacitor; set the capacitor at the midpoint of the range of maximum voltage. If resulting voltage is outside limits specified in Figure 6-9, replace card at A16 and repeat this entire procedure.
18. Disconnect channel A probe at test point "D".
19. Connect channel A and channel B probes to test points "C" and "F" respectively of card at location A16.
20. Set oscilloscope mode switch to ALTERNATE.

21. Make oscilloscope adjustment to achieve waveforms in Figure 6-9.1. Adjust position of upper trace so that lowest point on waveform is two divisions below a horizontal graticule line, and passes through the intersection of a horizontal and vertical graticule during the ongoing portion of the trace, (Point A, Figure 6-9.1).

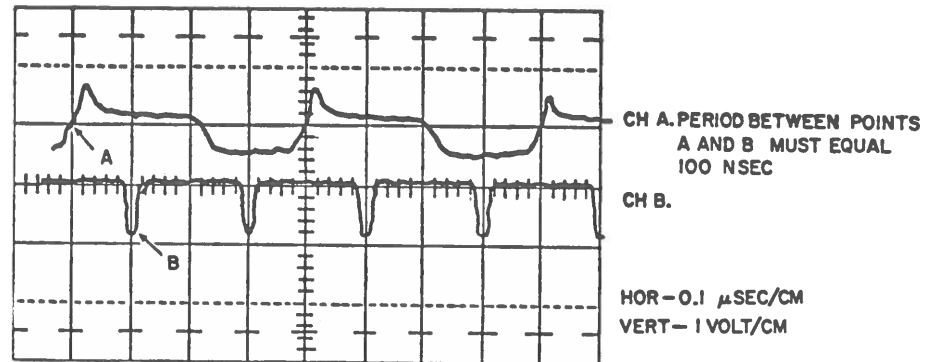

7x9

Figure 6-9.1. Symmetry Strobe Relation

22. Note whether the midpoint (point B) of the first negative pulse of channel B (lower trace), is centered on the first vertical graticule to the right of point A in Figure 6-9.1. Adjust lower variable resistor (5000 ohm) on edge of card at location A16 until trace is centered. If adjustment fails, replace card at location A16 and repeat this entire procedure.
23. Disconnect oscilloscope and close top cover.

DRIVE BELT REMOVAL AND REPLACEMENT (Figure 6-10)

1. Open cabinet front door and slide power supply out. Open rear door and swing logic chassis out.
2. Disable spindle lock mechanism by closing front cover.
3. Place replacement drive belt close at hand.
4. Disconnect leadwires to pack-on switch. Disconnect spindle ground strap from deck.
5. Remove ratchet brake linkage assembly from sector sensor positioner shaft and from the machine.
6. Move motor and brake assembly forward to the limit of the slots in the motor mounting plate (override idler spring force).
7. Drop drive belt from spindle drive pulley. Raise other end of belt clear of drive motor pulley.
8. Install replacement belt (smooth side of belt against pulleys) first on the spindle pulley and then around the drive motor pulley. The motor and brake assembly must be moved forward when installing the belt on the motor pulley.
9. Allow idler spring to pull on motor and brake assembly. Manually turn the spindle about ten revolutions to center belt on pulleys.
10. Restore electrical connections of step 4.
11. Install ratchet brake linkage assembly. Rotate linkage assembly clockwise (as viewed from below) on sector sensor shaft and secure in position so that brake pawl is held 0.04 ± 0.01 inch away from detent plate (Figure 6-10, detail C).

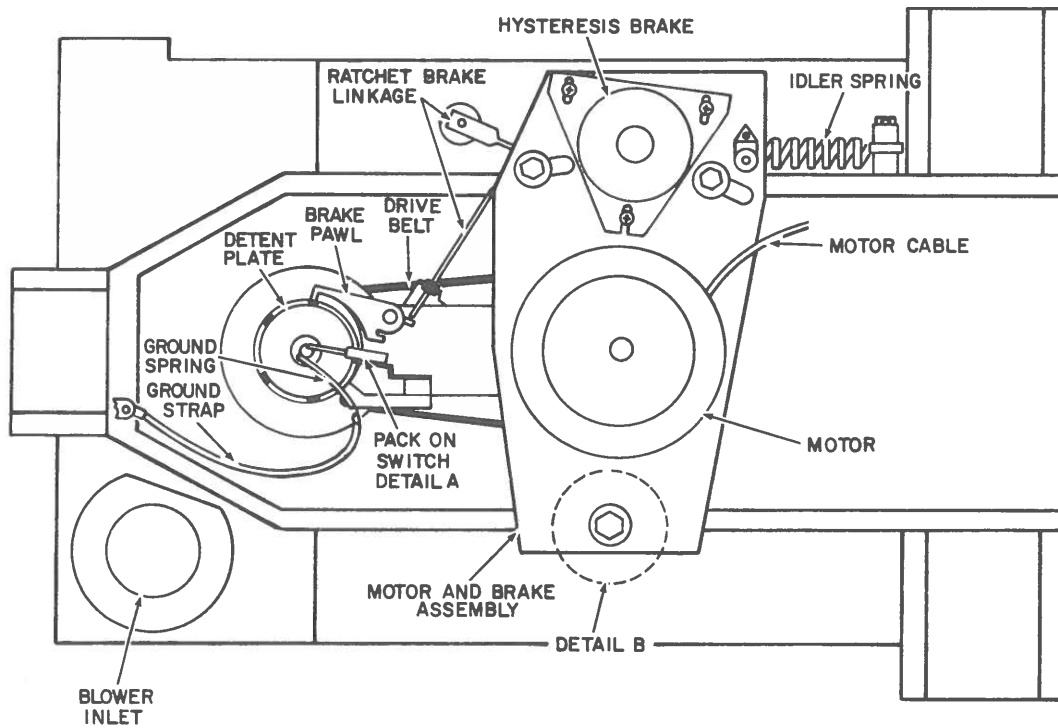

PACK ON SWITCH
DETAIL A

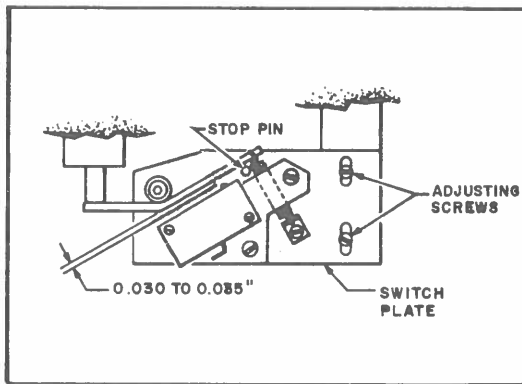

MOTOR BRAKE
ASSEMBLY MOUNTING
DETAIL B

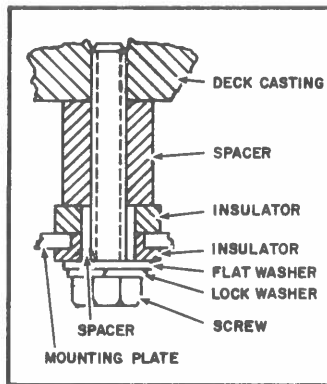

RATCHET BRAKE
DETAIL C

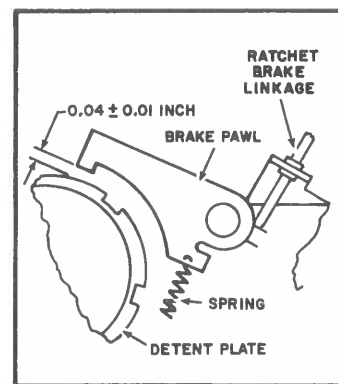

7F16B

Figure 6-10. Main Deck Underside

DRIVE MOTOR REMOVAL AND REPLACEMENT (Figure 6-10)

The drive motor is not field repairable. If trouble is experienced, replace it and return the faulty unit to the factory.

1. Open cabinet front door and set power supply SPINDLE MOTOR circuit breaker to OFF.
2. Slide power supply out of cabinet.
3. Open rear door and swing logic chassis out.
4. Disconnect drive motor cable plug and hysteresis brake cable plug.
5. Support motor and brake assembly and remove three screws securing assembly to underside of deck.
6. Allow idler spring to fall loose and raise drive belt clear of motor pulley.
7. Lower assembly clear of deck and remove from cabinet.
8. Loosen three screws securing brake plate to motor plate so as to relieve tension on V-belt.
9. Loosen setscrew(s) and remove drive pulley (Figure 6-11) from faulty motor.
10. Loosen setscrew(s) and remove V-belt pulley from faulty motor.
11. Remove four screws and washers and separate motor from motor mounting plate.
12. Align motor cable exit point to motor mounting plate according to Figure 6-10. Secure replacement motor to mounting plate.
13. Install V-belt pulley on motor shaft establishing required dimension (Figure 6-11) between bottom of pulley and top of motor mounting plate. Secure pulley to shaft with setscrew(s) using one drop of Loctite, Grade C, on setscrew(s) threads. Torque setscrew(s) to 75 ± 5 in.-lbs.
14. Set drive motor pulley (Figure 6-11) on motor shaft and allow it to slide down and contact V-belt pulley.
15. Apply one drop of Loctite, Grade C, to setscrew(s) threads. Use setscrew(s) to secure drive motor pulley to motor shaft. Torque setscrew(s) to 75 ± 5 in.-lbs.
Torque setscrew on keyway first and then setscrew on motor shaft.
16. Place V-belt over brake and motor V-belt pulleys.
17. Slide brake plate away from motor to establish moderate belt tension. Tighten screws securing brake plate to motor plate.

18. Place V-belt between forward and center tabs of belt tension gage (P/N 84267100) according to Figure 6-11. Use finger to press gage spring arm until rear tab just contacts belt. Spring arm must be at 14 (+2, -0) pounds on tension scale as rear tab contacts belt. Reposition brake mounting plate until requirement is met.

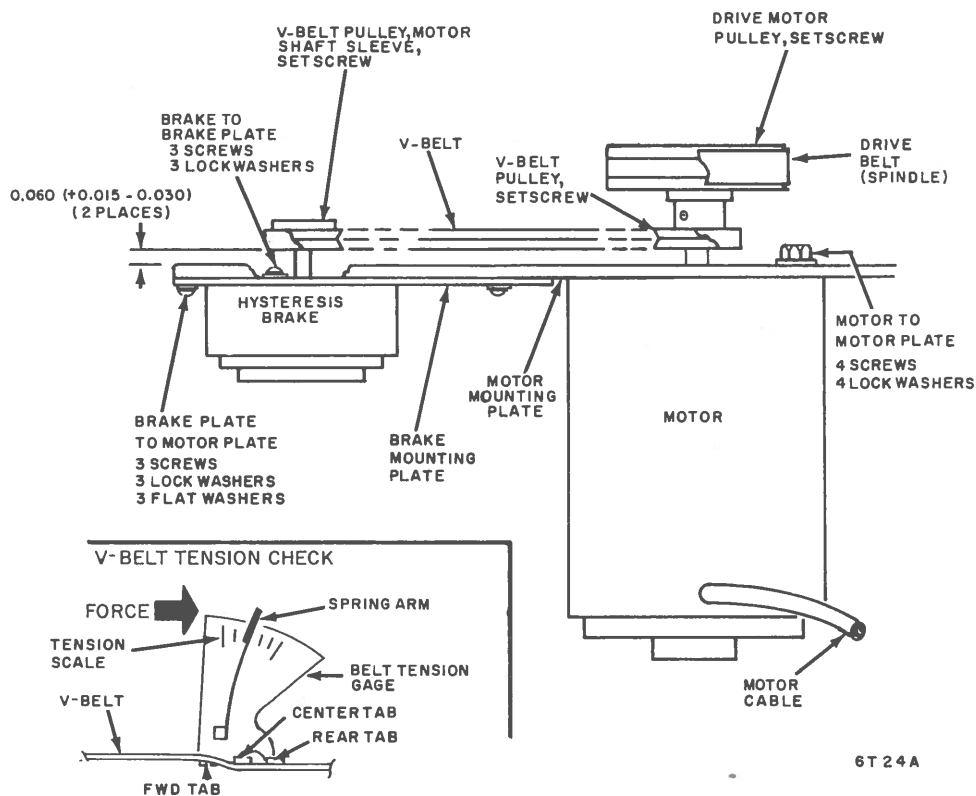

Figure 6-11. Motor and Brake Assembly

19. Raise motor and brake assembly toward underside of deck. Secure assembly to deck with three screws (Figure 6-10, detail B).
20. Place drive belt around spindle pulley and motor pulley so that the smooth side of belt is against the pulleys.
21. Connect idler spring to post on motor mounting plate (Figure 6-10).
22. Connect drive motor cable plug and hysteresis brake cable plug.

DRIVE MOTOR PULLEY REMOVAL AND REPLACEMENT (Figure 6-11)

1. Open cabinet front door and set power supply SPINDLE MOTOR circuit breaker to OFF.
2. Slide power supply out of cabinet.
3. Open rear door and swing logic chassis out.
4. Disconnect drive motor cable plug and hysteresis brake cable plug.
5. Move motor and brake assembly forward (against idler spring force).
6. Raise belt clear of drive motor pulley.
7. Allow drive belt to remain around spindle pulley.
8. Loosen setscrew(s) securing drive motor pulley to motor shaft and remove faulty pulley.
9. Apply one drop of Loctite, Grade C, to setscrew(s) threads.
10. Check that required dimension exists between bottom surface of V-belt pulley on motor shaft and top surface of motor mounting plate, Figure 6-11. If requirement is not met, loosen V-belt pulley setscrew(s), reposition pulley along shaft. Apply one drop of Loctite, Grade C, to setscrew(s) threads. Torque setscrew(s) to 75 ± 5 in.-lbs.
11. Set replacement pulley on motor shaft (Figure 6-11) allowing it to slide down and contact V-belt pulley.
12. Use setscrew(s) of step 9 to secure pulley to motor shaft. Torque setscrew(s) to 75 ± 5 in.-lbs.
Torque setscrew on keyway first and then setscrew on motor shaft.
13. Place drive belt around spindle pulley and motor pulley so that the smooth side of belt is against the pulleys.
14. Connect drive motor cable plug and hysteresis brake cable plug.

HYSTERESIS BRAKE OR BELT REMOVAL AND REPLACEMENT (Figure 6-11)

1. Open cabinet front door and set power supply SPINDLE MOTOR circuit breaker to OFF.
2. Slide power supply out of cabinet.
3. Open rear door and swing logic chassis out.
4. Disconnect drive motor cable plug and hysteresis brake cable plug.
5. Move motor and brake assembly forward (against idler spring force).

6. Raise belt clear of drive motor pulley.
7. Allow drive belt to remain around spindle pulley.
8. Loosen three screws securing brake plate to motor plate so as to relieve tension on V-belt.
9. Replace V-belt according to step 10. Replace hysteresis brake according to step 11.
10. Replace V-belt as follows:
 - a. Raise old belt clear of pulleys.
 - b. Loop replacement belt around pulleys.
 - c. Proceed to step 12.
11. Replace hysteresis brake as follows (Figure 6-11):
 - a. Remove setscrew securing V-belt pulley and motor shaft sleeve to brake shaft.
 - b. Remove three screws and washers securing faulty brake to brake plate.
 - c. Install replacement brake on brake plate with three screws and washers.
 - d. Assemble V-belt pulley (with motor shaft sleeve in hub) to brake shaft. Using a setscrew with one drop of Loctite, Grade C, on threads, establish the dimension specified in Figure 6-11 between the pulley and motor mounting plate, and secure the pulley and sleeve to the shaft.
 - e. Loop V-belt around V-belt pulleys.
12. Slide brake away from motor to establish moderate belt tension. Tighten screws securing brake plate to motor plate.
13. Place V-belt between forward and center tabs of belt tension gage (P/N 84267100) according to Figure 6-11. Use finger to press gage spring arm until rear tab just contacts belt. Spring arm must be at 14 (+2, -0) pounds on tension scale as rear tab contacts belt. Reposition brake mounting plate until requirement is met.
14. Place drive belt around spindle pulley and motor pulley so that the smooth side of belt is against the pulleys.
15. Connect drive motor cable plug and hysteresis brake cable plug.

SPINDLE LOCK PAWL

Check (Figure 6-10)

1. Open cabinet front door and slide power supply out.
2. Open rear door and swing logic chassis out.
3. Use feeler gage to ensure that brake pawl tip is separated from detent plate by 0.04 ± 0.01 inch (Figure 6-10, detail C).
4. Perform the adjustment procedure if requirement of step 3 is not met.

Adjustment (Figure 6-10)

1. Loosen screw securing ratchet brake linkage to bottom end of sector sensor positioner shaft (shaft protruding through deck).
2. Rotate linkage arm until connecting rod holds the brake pawl clear of the detent plate by 0.04 ± 0.01 inch (Figure 6-10, detail C).
3. Retighten the screw through the linkage arm.
4. Push power supply in and swing logic chassis in; close front and rear doors.

PACK ON SWITCH

Check and Adjustment (Figure 6-10)

1. Open cabinet front door and slide power supply out.
2. Remove right side panel.
3. With no pack on spindle, check for 0.030 to 0.035 clearance between actuator arm and stop pin. Adjust by loosening two adjusting screws and repositioning switch plate assembly.
4. Place pack on spindle, rotating pack handle clockwise until switch contacts transfer (audible).

5. Check for 0.005 to 0.010 clearance between actuator arm and stop pin. Adjust by loosening two screws in switch adjustment bracket and rotating switch as necessary.
6. Replace right side panel.
7. Push power supply in cabinet and close front door.

Removal and Replacement (Figure 6-10)

1. Open cabinet front door and slide power supply out.
2. Remove right side panel.
3. Disconnect switch wires (at connector P322, Series Code 12 and above).
4. Remove two screws, washers, and the switch.
5. Install replacement switch, screws, and washers.
6. Reconnect wires to switch (at connector P322, Series Code 12 and above).
7. Adjust switch (see Check and Adjustment procedure).
8. Install right side panel.
9. Push power supply in and close front door.

GROUND SPRING CHECK AND ADJUSTMENT

1. Open cabinet front door and slide power supply out.
2. Open rear door and swing logic chassis out.
3. Insert a non-metallic feeler gage (0.005 inch) between ground spring and spindle shaft.
4. Hook a push-pull gage (12210797) to extreme free end of ground spring.

NOTE

Multimeter provides most accurate indication of physical separation.

5. Force (applied perpendicular to spring) required to release and allow feeler gage to fall should be between 3.53 and 5.30 ounces.
6. If requirement is not met, loosen mounting block and reposition it slightly. Tighten screw securing mounting block and repeat steps 3 through 5.

SPINDLE AND LOCKSHAFT ASSEMBLY

Field repair of this assembly is limited to replacing the lockshaft. If the trouble being experienced cannot be remedied by replacing the lockshaft, replace the entire spindle and lockshaft assembly. Return the faulty assembly to the factory.

Lockshaft Removal and Replacement

1. Remove left and right side panels.
2. Open cabinet front door and slide power supply out.
3. Disconnect pack on switch wires (at connector P322, Series Code 12 and above).
4. Disconnect ground strap from deck.
5. Remove two screws and two washers securing pack on switch assembly to switch mount.
6. Remove two screws and two washers securing ground spring mount assembly to switch mount.
7. Open cabinet front cover and turn spindle until brake pawl engages detent plate.
8. Remove the lock nut and stop washer from the lower end of the lockshaft.
9. Carefully raise lockshaft out of top of spindle assembly.
10. Lower replacement lockshaft into top of spindle assembly.

CAUTION

Installed lockshaft must move freely without binding on internal spring.

11. Install stop washer and lock nut on lower end of lockshaft.
12. Tighten lock nut to a torque of 20 inch-pounds minimum.
13. Reassemble remaining components to spindle by reversing steps 3 through 6.
14. Perform Pack On Switch Check and Adjustment procedure.
15. Perform Ground Spring Check and Adjustment procedure.
16. Install side panels.
17. Push in power supply and close front door and cover.

Spindle and Lockshaft Assembly Removal and Replacement

1. Open cabinet front cover. Remove nine screws and washers on inner bottom of shroud. Remove brush cover.
2. Close cabinet front cover and open cabinet top cover. Raise shroud clear of deck and set aside.
3. Open front door and slide power supply out.
4. Open rear door and swing logic chassis out.
5. Remove ratchet brake linkage assembly (Figure 6-10) by loosening screw on linkage arm.
6. Disconnect pack on switch wires (at connector P322, Series Code 12 and above).
7. Disconnect ground strap from deck.
8. Force motor and brake assembly forward (against idler spring force) and remove drive belt from drive motor pulley. Allow belt to fall below spindle.
9. Remove five nuts and ten washers from screws securing spindle assembly to deck. Remove the five screws.
10. Close cabinet top cover and open front cover.

CAUTION

Do not pry on spindle mounting surface of the deck.

11. Using a screwdriver, pry spindle up and off of the two roll pins that locate it on the deck. Two pry surfaces are provided directly below the spindle surface and forward of the roll pins.
12. Lift spindle assembly from deck being careful not to damage the lockshaft or ratchet brake as the spindle comes through the deck hole.
13. Remove ratchet brake assembly from faulty spindle assembly and install it on replacement spindle assembly. Allow brake pawl to engage detent plate notch and then tighten screws securing brake to spindle.
14. Place replacement spindle on deck being careful not to damage the lockshaft or the ratchet brake assembly when lowering the assembly through the deck.

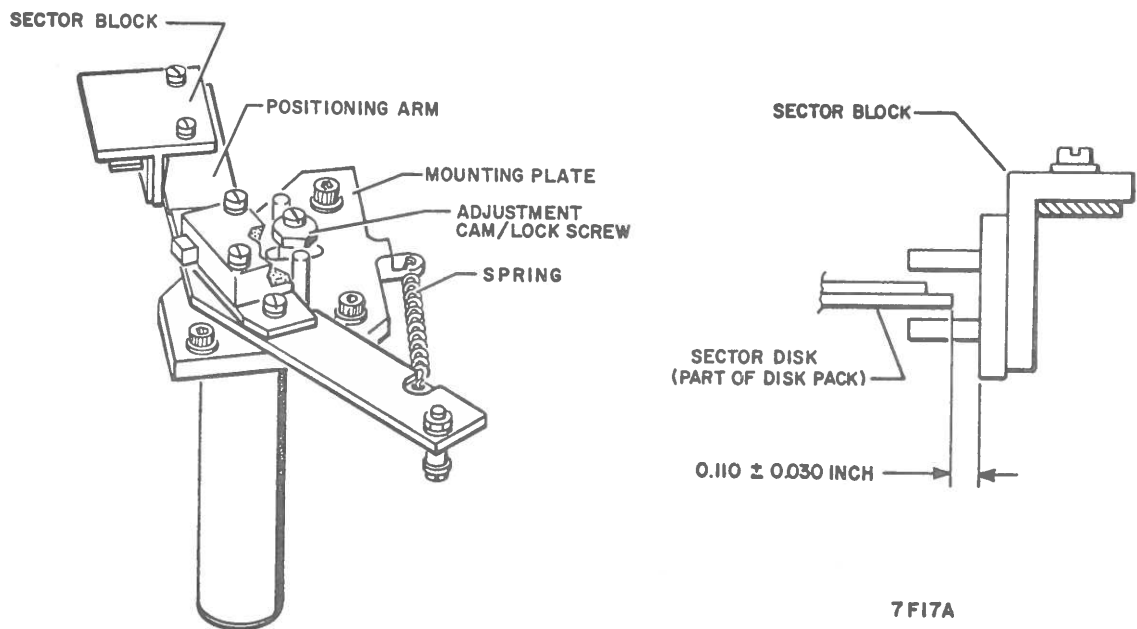

Figure 6-12. Index Sensor

CAUTION

Tighten the spindle down evenly over the roll pins keeping the spindle surface parallel to the mating deck surface.

15. Close cabinet front cover and open cabinet top cover.
16. Replace five bolts, ten washers, and five nuts. Tighten this hardware evenly so that the spindle flange and deck flange are kept parallel to each other.
17. Reassemble components in reverse order of steps 5 through 8.
18. Perform Carriage Alignment procedure.
19. Perform Ground Spring Check and Adjustment procedure.
20. Perform Pack On Switch Check and Adjustment procedure.
21. Perform Head/Arm Adjustment procedure.
22. Perform Index to Burst Check and Adjustment procedure.

23. Perform Spindle Lock Pawl Check and Adjustment procedure.
24. Install shroud and perform Shroud Adjustment procedure.
25. Install brush cover.

INDEX SENSOR ASSEMBLY

Sensor Stop Check and Adjustment

1. Stop spindle motor. Set DC switch to OFF.
2. Open cabinet front cover.
3. Remove disk pack from spindle. Avoid contact with index transducer.
4. Remove nine screws and washers securing shroud to deck.
5. Close cabinet front cover and open top cover. Raise shroud clear of deck and set aside. Remove brush cover.
6. Close cabinet top cover and open front cover. Install CE disk pack (P/N 89259000) on spindle. Avoid contact with index transducer.
7. Open cabinet top cover. Manually rotate disk pack. Stop rotation when edge of sector disk is nearest the inner vertical surface of sector block (Figure 6-12).
8. Measure gap between adjacent edge of sector disk and sector block surface. The gap must be between 0.110 ± 0.030 inch (Figure 6-12). Adjust as follows:
 - a. Loosen two screws securing sector block to positioning arm.
 - b. Reposition sector block on positioning arm until proper dimension is achieved.
 - c. Tighten screws securing sector block and recheck gap. Readjust if required.
9. Remove CE disk pack from spindle. Avoid contact with index transducer.
10. Install shroud and perform Shroud Adjustment procedure.
11. Install brush cover.

Index to Burst Check and Adjustment

1. Stop spindle motor.

CAUTION

Failure to turn ± 36 V circuit breakers off may cause uncontrolled head loading and unloading operations.

2. Set DC switch to OFF. Set ± 36 V circuit breakers to OFF.
3. Open cabinet top cover.
4. Remove SPL card at location E04.

CAUTION

The CE disk pack contains specially recorded tracks of data. Extreme care must be taken so that this data is not modified.

5. Install CE disk pack (P/N 89249000). Avoid contact with index transducer.
6. Check hub of disk pack for presence of label specifying index to data period. If label is found, make a note of value specified.
7. Set ON LINE/OFF LINE switch to OFF LINE.
8. Set DC switch to ON.
9. Start spindle motor.
10. Manually position carriage to track 236. Use masking tape to secure carriage at this position.
11. Select head 10 by connecting a jumper wire between test points 10 and Y (ground) of the SPL card at location E01.
12. Connect oscilloscope external trigger to test point C (Index) of card at location A02.
13. Connect oscilloscope channels A and B to test points G and F of SPL card at location E05. Ground oscilloscope at test point A of same card.
14. Refer to Figure 6-13 for oscilloscope settings. Compare traces. Period between Index pulse and peak of first Data pulse must be as follows: $3 \pm 3 \mu\text{sec}$ if no label was found on disk pack hub, or as specified on disk pack hub. If requirement is not met, adjust as follows:

- a. Loosen three screws securing mounting plate to deck (Figure 6-12).
 - b. Loosen lock screw in adjustment cam. Rotate adjustment cam clockwise or counterclockwise until requirement for period (step 14) is met.
 - c. Tighten screws securing mounting plate to deck. Be careful not to change period adjustment.
 - d. Tighten lock screw in adjustment cam.
 - e. Check the period and readjust if required.
15. Disconnect oscilloscope external trigger. Set triggering to internal.
 16. Disconnect channel probes.
 17. Connect channel A probe to test point C (Index) of card at location A02.
 18. Trace must indicate a logic "1" (+3 vdc) pulse with a width of $55.0 \pm 8.25 \mu\text{sec}$ (Figure 6-14). If requirement is not met, a failure has occurred in term Y601.
 19. Disconnect oscilloscope.
 20. Stop spindle motor and remove CE disk pack. Avoid contact with index transducer.
 21. Install card removed in step 4. Remove masking tape used in step 10.
 22. Perform Spindle Lock Pawl Check and Adjustment procedure.

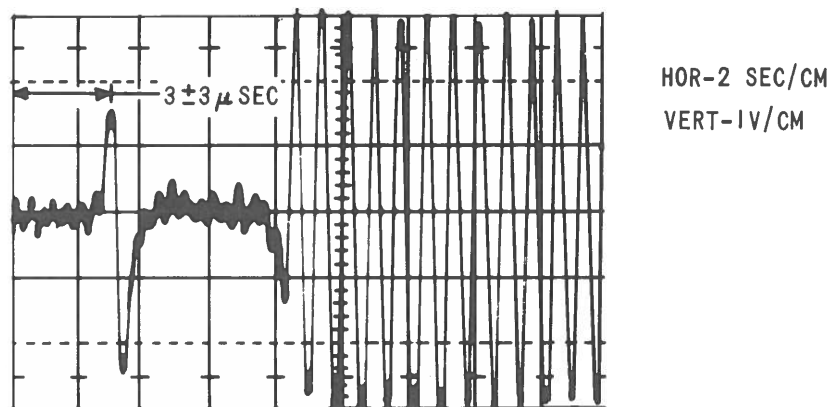

6T60

Figure 6-13. Index to Burst Period

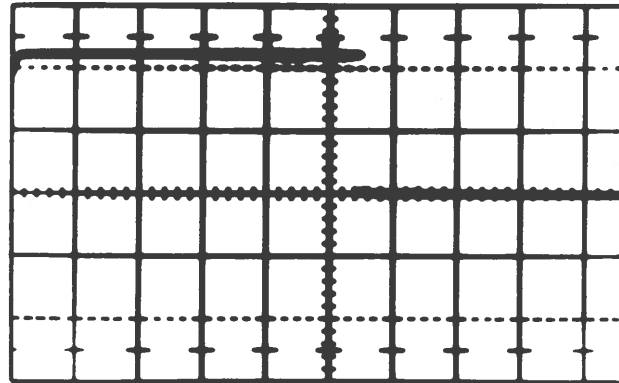

TPC AT A02
 HOR-10 μ SEC/CM
 VERT-2V/CM

6T6I

Figure 6-14. Detector Trace

Index Transducer Removal and Replacement

1. Stop spindle motor.
2. Open cabinet rear door and set ON LINE/OFF LINE switch to OFF LINE. Set DC switch to OFF.
3. Open cabinet front cover. Remove disk pack from spindle.
4. Remove nine screws and washers securing shroud to deck.
5. Close front cover and open cabinet top cover. Raise shroud clear of deck and set aside. Remove brush cover.
6. Disconnect sector block cable plug and cut cable ties securing cable to positioning arm.
7. Remove two screws and washers securing sector block assembly to positioning arm (Figure 6-12). Remove assembly from deck area.
8. Install replacement sector block assembly by reversing steps 6 and 7. Position the sector block as far away from spindle as slots will allow. Make certain that sector block leadwires are secured to positioning arm with new cable ties.
9. Perform steps 6 through 10 of the Sensor Stop Check and Adjustment procedure.
10. Perform Index to Burst Check and Adjustment procedure.

Transducer Output Check

1. Open cabinet front cover and install disk pack.
2. Close cabinet front cover.
3. Open cabinet rear door. Connect oscilloscope channel probe to wire wrap pin 9B at location A02. Ground oscilloscope at test point A of card at location A02.
4. Set oscilloscope trigger to internal and negative.
5. Make oscilloscope settings according to Figure 6-15.
6. Start spindle motor and allow heads to load.
7. Examine trace for agreement with requirements of Figure 6-15.
8. If any requirement is not met, replace the index transducer.

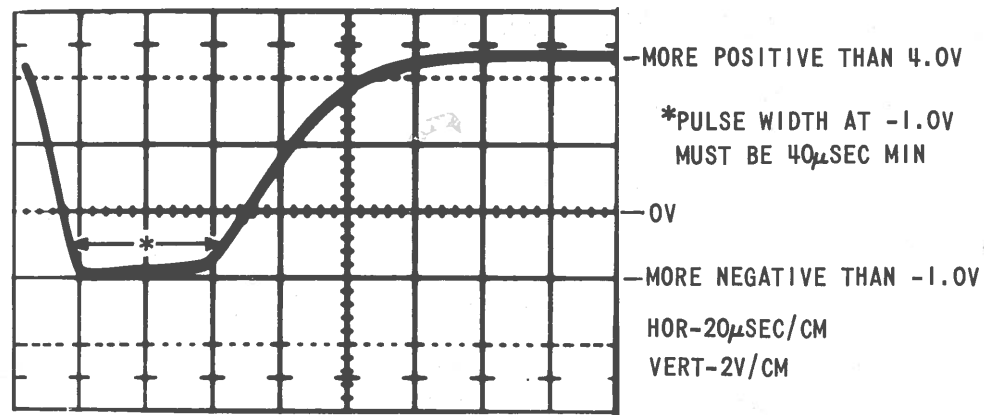

6T62

Figure 6-15. Index Transducer Trace

SHROUD ADJUSTMENT

1. Make certain that nine screws in bottom of shroud are loose enough to allow shroud to be positioned laterally.
2. Install disk pack.
3. Visually inspect clearance between entire circumference of disk pack sector disk and adjacent interior surface of shroud.

4. If clearance is uniform remove disk pack from spindle. Tighten nine screws in bottom of shroud. Make certain shroud does not shift from established position.
5. If clearance is not uniform, adjust as follows:
 - a. Position shroud laterally to meet requirement of step 3.
 - b. Remove disk pack from spindle.
 - c. Tighten nine screws in bottom of shroud making certain that shroud does not shift from original position.

DISK CLEANER ASSEMBLY

Check (Figure 6-16)

1. Open cabinet top cover.
2. Remove disk cleaner cover and attaching screw.
3. Using feeler gauge, make certain that dimensions A and B (Figure 6-16) are a minimum of 0.010 inch as brushes reach limits of their travel.
4. Using multimeter, check that continuity (0 ohms on meter) exists between brush switch (S301) posts 2 and 3 with brushes retracted. Meter must indicate infinity between posts 1 and 3 with brushes in this position.
5. With brushes extended, continuity must exist between switch posts 1 and 3. No continuity should exist between posts 2 and 3.
6. Perform adjustment procedure if required.
7. Install disk cleaner cover and attaching screw.

Adjustment (Figure 6-16)

Unless otherwise specified, brushes must follow linkage movement (brush detenting mechanism engaged).

1. Make certain brush assembly detent mechanism is engaged (brushes follow movement of linkage).
2. Loosen two setscrews securing linkage to motor shaft and two setscrews securing cam brush link to brush arm shaft.
3. Set brush holder against brush stop with detent mechanism engaged. Align linkage according to part A, Figure 6-16. Tighten two setscrews securing linkage to motor shaft. Adjust dimension between cam brush link and disk cleaner base according to part C, Figure 6-16. Tighten two setscrews in cam brush link.

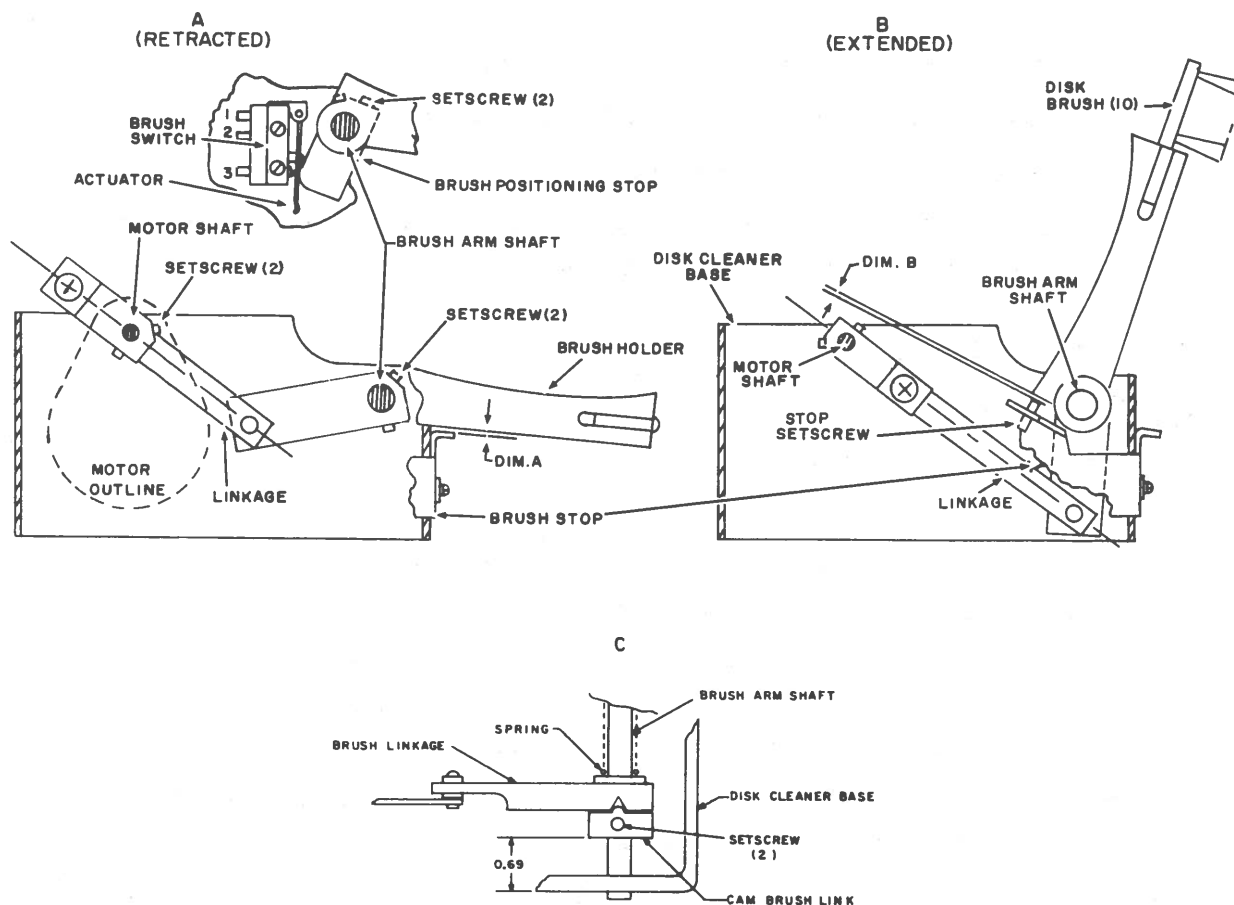

6T26

Figure 6-16. Disk Cleaner Adjustment

4. Loosen two screws securing brush stop. Place 0.020-inch shim or feeler gauge between lower brush holder and brush stop (dimension A, Figure 6-16). Remove slack in linkage by pressing brush stop toward brush holder and tighten two screws securing brush stop.
5. Align linkage according to part B, Figure 6-16. Using a shim or feeler gauge, turn stop setscrew to establish a 0.020-inch gap (dimension B, Figure 6-16) between stop setscrew and brush holder.

6. Align linkage according to part A, Figure 6-16. Loosen two setscrews securing brush positioning stop. Rotate brush positioning stop against brush switch actuator until the switch plunger bottoms out and tighten both setscrews. Switch actuating arm should not be bent or flexed with the plunger bottomed.

Removal and Replacement (Figure 6-16)

No special instructions are required for removal and replacement except, when replacing motor or switch, use 2 drops of Loctite, Grade C, on threads of each securing screw. Perform check procedure following any replacement.

HEAD SELECT PREAMPLIFIER CARD REMOVAL AND REPLACEMENT

1. Stop spindle motor.
2. Open cabinet rear door and set DC switch to OFF.
3. Open cabinet top cover. Remove head cable clamp assembly.
4. Disconnect each head cable plug connected to edge of cards at locations E01, E02, and E03 (Figure 6-17).
5. Remove two wing studs at front of preamplifier card chassis and rotate chassis clear of carriage.
6. Carefully extract card from chassis by pulling card straight away from connector.
7. Install replacement card carefully so that connector pins are not damaged.
8. Rotate preamplifier chassis into place and secure with two wing studs.

NOTE

Head cables should not cross. Plug of top read/write head connects to top position on edge of card at E01. Plug of bottom read/write head connects to bottom position on edge of card at E02. Servo head cable must be connected to edge of card at location E03.

9. Connect head cable plugs to edge of head select preamplifier cards and track servo card (Figure 6-17). Replace head cable clamp assembly.
10. Set DC switch to ON.

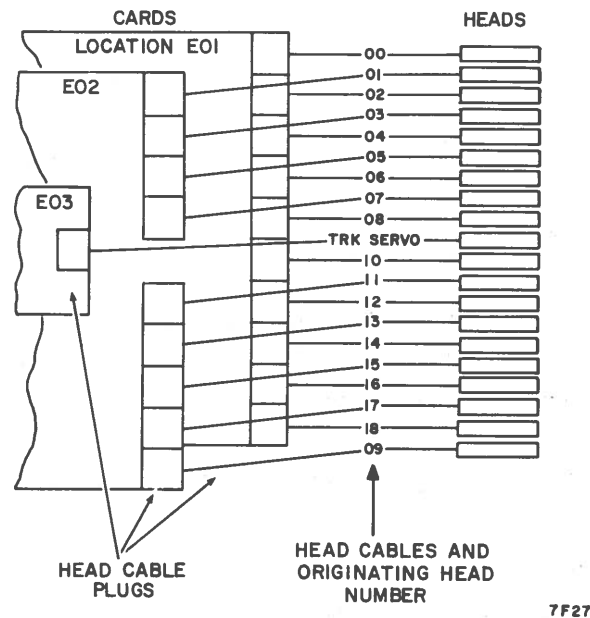

Figure 6-17. Read/Write Head Cable Connections

HEADS LOADED SWITCH

Check

1. Stop spindle motor.
2. Open cabinet rear door and set DC switch to OFF.
3. Open cabinet top cover.
4. Remove disk pack.

NOTE

Switch transfer may be monitored by listening for an audible click or by connecting a multimeter across the switch leadwire terminals.

5. Retract carriage to retracted stop.
6. Slowly extend carriage. Stop carriage at point where switch transfer occurs and check distance traveled.
7. If necessary, loosen switch and adjust to achieve 0.180-0.260 (0.240 minimum*) inches of travel.
8. Retract carriage from switch transfer point in step 6 above until second click is heard. Replace switch if distance traveled exceeds 0.150 (0.200*) inches.

*for units with serial numbers 4847, 4849, 4851, 4857-4859, 4861, 4863, 4864, 4865-4867, 4912-4941, 4974-5000, 5055-5081, and 5140-5153.

9. Replace disk pack and close front cover.
10. Set DC switch to ON and close rear door.

Removal and Replacement

No special instructions are required for removal and replacement except, when replacing switch, use one drop of Loctite, Grade C, on threads of each screw securing switch to mounting bracket. Perform Heads Loaded Switch Check procedure following any replacement.

VELOCITY TRANSDUCER

Check

NOTE

In following procedure it is necessary to Command Seek operations. These commands may be derived by either suitable software and the central processor or the access tester card (P/N 54116100) installed in logic chassis (location C30). Whenever a Command is derived from the access tester card, set the unit ON LINE/OFF LINE switch to OFF LINE.

1. Install a disk pack.
2. Open cabinet rear door. Connect oscilloscope channel probe to test point G (velocity integrator) of card at location A27.
3. Connect oscilloscope external trigger to test point M (T>32) of card at location A27. Set triggering for negative.
4. Connect oscilloscope ground to GRD jack on logic chassis maintenance panel.
5. Set oscilloscope horizontal to 2 ms/cm and vertical to 2 v/cm.
6. Start unit and allow heads to load. Command a 405 track repeat seek.

NOTE

The oscilloscope displays the velocity integrator saw-tooth (ramps) output for the last 32 tracks of the seek. The positive ramps occur at the end of a forward seek, the negative ramps are related to the reverse seek.

7. The next to last positive ramp and the next to last negative ramp must have an amplitude of 2.6 ± 0.3 volts. The absolute values of the next to last two ramp-amplitudes must agree to within $+0.5$ volts maximum. The last positive ramp and the last negative ramp must have amplitudes of 1.1 ± 0.2 volts.
8. If the above requirements are not met, perform the Integrator Gain Check/ Adjustment procedure, then repeat this procedure. If requirements are still not met, replace velocity transducer.

Removal and Replacement (Figure 6-18)

1. Open cabinet rear door and set filter box circuit breaker to OFF.
2. Open cabinet top cover.
3. Refer to Figure 6-18 and disconnect plug P304.
4. Remove two screws and washers securing velocity transducer and end cap to rear surface of magnet assembly. Retain cap, screws and spring (located inside cap).

CAUTION

Use care throughout following procedures so the extension rod does not get bent.

5. Use a pliers to unthread extension rod at the point it enters the rear of the head/arm receiver.
6. Carefully pull transducer magnet and extension rod out of the end cap end of transducer coil/housing.
7. Pull transducer coil/housing from magnet assembly.
8. Carefully unthread extension rod from transducer magnet. Moderate force may be required since Loctite was used on rod threads.

CAUTION

The magnet in the replacement velocity transducer may be rendered unuseable if it is allowed to touch a metal object. Keep it in shipping container until it is to be installed.

9. Slide replacement transducer coil/housing into magnet assembly.

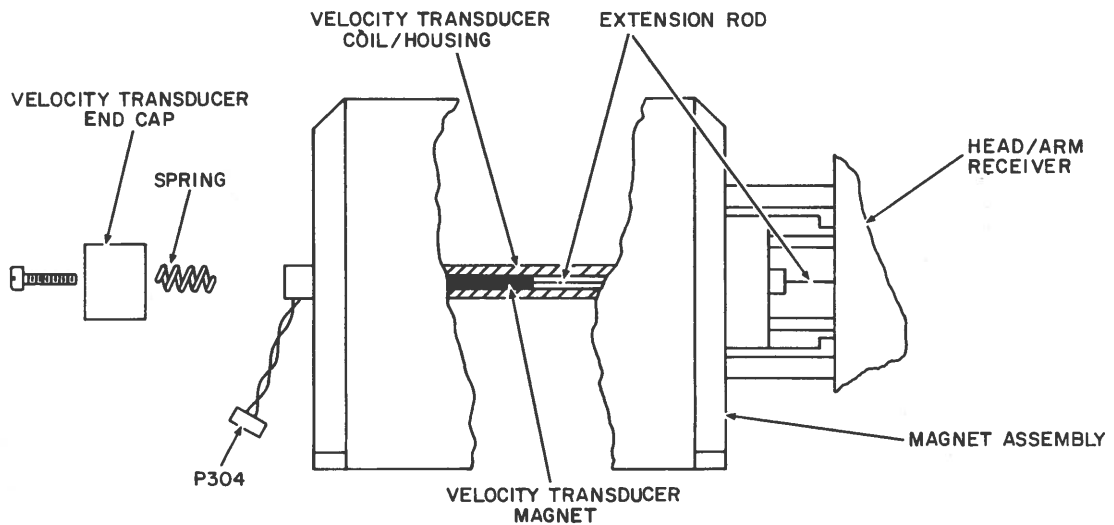

6T52

Figure 6-18. Velocity Transducer Replacement

10. Observing the earlier caution, carefully remove replacement transducer magnet from shipping container.
11. Grasp transducer magnet securely and carefully insert one end of it into coil/housing bore. Determine which end of transducer magnet is attracted into bore. This is the end in which the extension rod must be installed in the next step. Note the end and return magnet to shipping container.
12. Apply one drop of Loctite, Grade C, to the extension rod threads that mate with transducer magnet. Thread rod into proper end of replacement magnet. Tighten with fingers only.
13. Carefully insert free end of extension rod into bore of coil/housing. Slide assembly into bore until threads of extension rod are visible behind head/arm receiver.
14. Apply one drop of Loctite, Grade C, to extension rod threads. Use a pliers and only moderate force to install extension rod tip in head/arm receiver.
15. Manually move carriage forward until transducer magnet is fully received into coil/housing bore.
16. Assemble spring and transducer end cap to rear surface of magnet assembly using two screws and washers.

17. Connect plug P304.
18. Perform Velocity Gain Check/Adjustment procedure.
19. Perform Integrator Gain Check/Adjustment procedure.
20. Perform Velocity Transducer Check procedure.

CARRIAGE ALIGNMENT

A carriage assembly is properly aligned when carriage motion is along a radial line to the spin axis of the spindle assembly. The following adjustment is required whenever the five screws securing the actuator mounting plate to the deck casting are loosened, or the spindle assembly is loosened from the deck casting.

1. Refer to Head/Arm Removal and Replacement procedure (steps 1 through 11) and remove the track servo head.
2. Install carriage alignment arm (P/N 87371200) on carriage at track servo head position.
3. Tighten head/arm clamps and alignment arm in place.
4. Install carriage alignment ring (P/N 87351000) on spindle cone.

CAUTION

Read/Write heads must be clean to prevent damage during the following operations. There is no requirement to protect heads if reasonable care is used. Protective pads or the use of other foreign materials may only introduce contaminants to the heads. Never touch a head face with fingers.

5. Inspect read/write heads and clean them if necessary, according to the procedures in the Preventive Maintenance section of this manual.
6. Slowly extend carriage until carriage alignment arm and ring are aligned approximately as shown in Figure 6-19.

NOTE

The actuator mounting plate pivots on a pin located beneath and to the rear of magnet assembly. Pivoting motion is tangential to the spindle and can occur only if the five screws securing the mounting plate to the deck are loose.

7. Check that clearance between ring and arm tools is as specified in Figure 6-19.

8. If adjustment is required, loosen five screws in mounting plate and establish required clearance between tools. Carefully and evenly tighten five screws securing plate to deck. Recheck clearance and readjust if required.

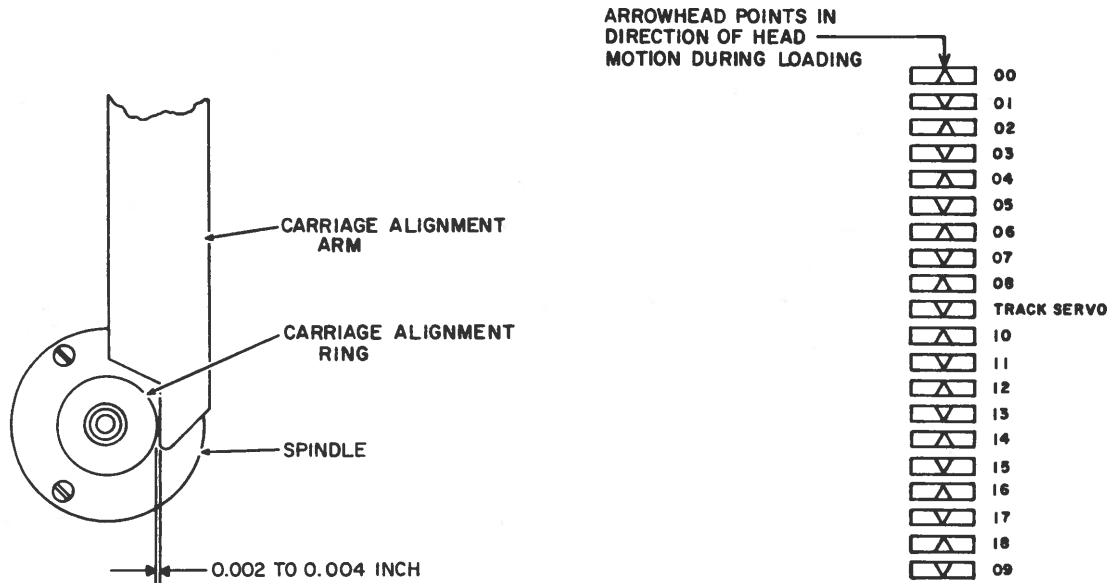

7F18

Figure 6-19. Carriage Alignment

9. Refer to Head/Arm Removal and Replacement Procedure and install track servo head.
10. Install shroud with eight screws and washers.
11. Perform Shroud Adjustment procedure.
12. Perform Head/Arm Adjustment procedure.
13. Perform Index to Burst Check and Adjustment procedure.

DC OFFSET CHECK/ADJUSTMENT

1. Open cabinet front cover.
2. Install a disk pack and close front cover.
3. Start unit and allow heads to load.
4. Using a volt/ohmmeter, measure the voltage at test points D, G, H, J, and K of card at location A26. The voltage at each test point must be 0 ± 0.5 volts dc.

5. If requirement is met, go to step 6. If requirement is not met, proceed as follows:
 - a. Stop unit and allow heads to unload, then start unit and allow heads to load.
 - b. Repeat step 4.
 - c. If requirement of step 4 is still not met, troubleshoot logic related to test point not meeting requirement.
6. Use a volt/ohmmeter to check the voltage at test point H of card at A27. Meter must indicate 0 ± 20 millivolts. If requirement is met, check is complete. If requirement is not met, adjust as follows:
 - a. Stop spindle motor.
 - b. Open cabinet rear door and set DC switch to OFF.
 - c. Swing logic chassis out and install card at location A27 on full-size card extender (P/N 54109700).
 - d. Plug card extender into logic chassis at location A27.
 - e. Set DC switch to ON.
 - f. Start spindle motor and allow heads to load.
 - g. Repeat step 4 (and 5 if required).
 - h. Connect volt/ohmmeter to test point H of card at A27.

NOTE

Card at location A27 has two potentiometers mounted on it. The dc offset potentiometer is located away from the outer (when installed) edge of the card.

- i. Adjust shaft on dc offset potentiometer for an indication of 0 millivolts (± 10 mv tolerance is allowable).
- j. Set DC switch to OFF. Disconnect meter and remove card extender.

TRACK SERVO AMPLITUDE ADJUSTMENT

1. Open cabinet front cover.
2. Install a disk pack and close front cover.
3. Start unit and allow heads to load.
4. Open cabinet rear door.
5. Connect oscilloscope external trigger to test point C (Index) of card at location A02. Set trigger to positive.
6. Connect channel A of oscilloscope to test point B of card at location A23.
7. With heads loaded, set the ± 36 volt circuit breaker to OFF. Manually move the carriage slowly between tracks 00 and 50.
8. Set the peak to peak amplitude to 2.0 (+0.4, -1.0) volts by adjusting upper potentiometer on card at location A23.

POWER AMPLIFIER CHECK/ADJUSTMENT

The power amplifier potentiometer is adjusted at the time of manufacture and need not be readjusted unless it is replaced or inadvertently adjusted.

1. Stop spindle and allow heads to unload.
2. Disconnect the main ac power cable bringing power to filter box.



3. Open cabinet front door.
4. Release six half-turn fasteners and open front and top doors of power supply.
5. Using a volt/ohmmeter and referring to Figure 6-20, measure the resistance between the top and bottom terminals of the 200-watt resistors R8 and R9.

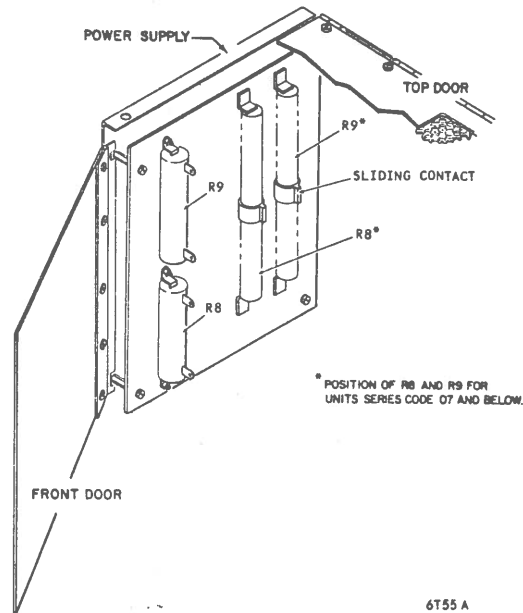

Figure 6-20. Power Amplifier Adjustment

6. Meter must indicate a resistance of 0.9 ± 0.1 ohms (0 ± 0.2 , Series Code 07 and below). If requirement is met, check is complete. If requirement is not met, go to step 7 for units Series Code 07 and below and step 8 for units Series Code 08 and above.
7. Loosen nut on resistor sliding contact just enough to allow contact to slide. Reposition sliding contact for an indication of 0.9 ohms (± 0.2 ohm tolerance is allowable). Tighten sliding contact nut. Ensure resistance has not changed. Go to step 9.
8. Change resistors until requirement is met.
9. Perform Velocity Gain Check/Adjustment procedure.
10. Perform Fine Position Gain Check/Adjustment procedure.
11. Perform Integrator Gain Check/Adjustment procedure.
12. Perform Velocity Transducer Check procedure.
13. Close power supply front and top doors and cabinet front door.

VELOCITY GAIN CHECK/ADJUSTMENT

1. Open cabinet front cover. Install a disk pack and close front cover.
2. Start unit and allow heads to load.
3. Open cabinet rear door.
4. Connect oscilloscope external trigger to test point L (Forward) at location A27. Trigger may be set for either positive or negative.
5. Connect channel A of oscilloscope to test point G (on Cylinder) at location A28.
6. Connect channel B of oscilloscope to test point G (Current Sense) at location A29.
7. Set both channels to Chop mode.

NOTE

In following procedure it is necessary to Command Seek operations. These commands may be derived by either suitable software and the central processor or the access tester card (P/N 54116100) installed in logic chassis (location C30). If Commands are derived from access tester card, set unit ON LINE/OFF LINE switch to OFF LINE.

8. Command unit to perform a 405 track repeat seek between tracks 0 and 405.
9. Make oscilloscope sensitivity settings according to Figure 6-21.
10. Compare the resulting trace to Figure 6-21. If the trace meets the requirement of the figure, disconnect oscilloscope. Check is complete.
11. If requirement is not met, adjust potentiometer shaft on card at location A28 until trace and figure agree. Disconnect oscilloscope.

FINE POSITION GAIN CHECK/ADJUSTMENT

1. Open cabinet front cover. Install a disk pack and close front cover.
2. Start unit and allow heads to load.
3. Connect oscilloscope external trigger to pin 9A (Any Seek) at location A18. Set trigger to positive.
4. Connect oscilloscope ground lead to GND jack on logic chassis maintenance panel.

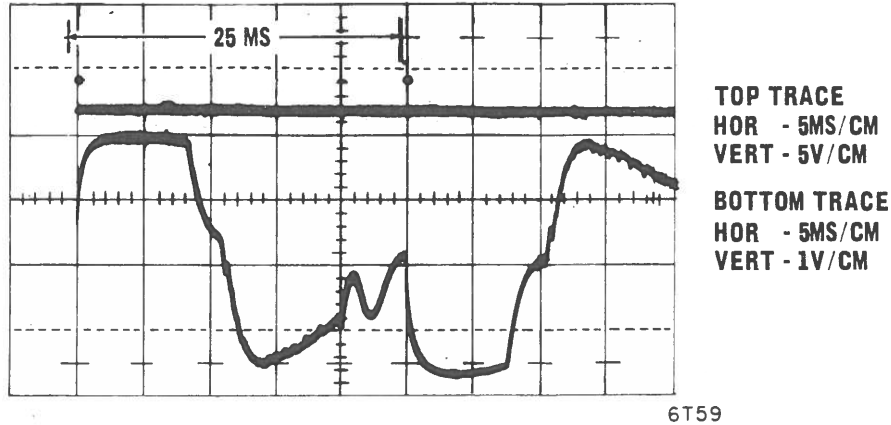

Figure 6-21. Velocity Gain Adjustment

5. Connect one channel of oscilloscope to test point D (Fine Position) at location A25. Set horizontal sensitivity to 1 ms/cm and vertical sensitivity to 2 v/cm.
6. Connect other oscilloscope channel to test point J (On Cylinder Delay) at location A28.
7. Set both channels to Chop mode.

NOTE

In following procedure it is necessary to Command Seek operations. These commands may be derived by either suitable software and the central processor or the access tester card (P/N 54116100) installed in logic chassis (location C30).

- a. If Command is derived from central processor, use a sequential read so as to keep unit on cylinder at each track for about 25 ms.
 - b. If Command is derived from access tester card, set unit ON LINE/OFF LINE switch to OFF LINE and connect a jumper wire between pin 13A at location C30 and test point J at location A18.
8. Command a one track sequential forward seek (405 tracks forward, 1 track at a time) from track 0.

NOTE

Each of the 405 movements constitutes a Seek operation. A trace will occur for each Seek. If variations occur in trace characteristics, they will occur gradually as the unit moves from one track to the next. Failure to meet a requirement will generally be preceded by a trend in that direction.

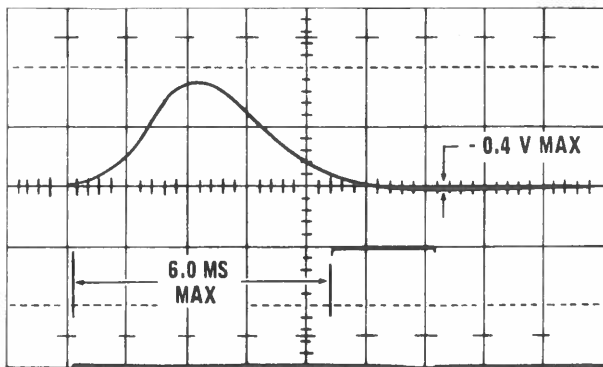

A CORRECT

HOR - 1MS/CM
VERT - 2V/CM

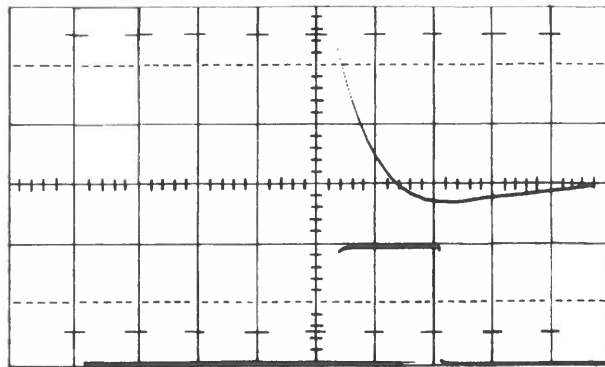

B CORRECT

HOR - 1MS/CM
VERT - 0.2V/CM

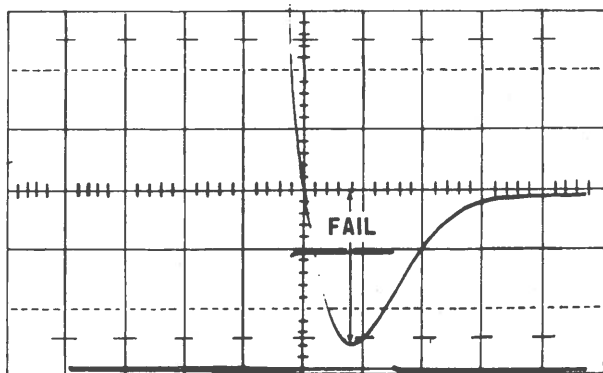

C GAIN TOO HIGH

HOR - 1MS/CM
VERT - 0.2V/CM

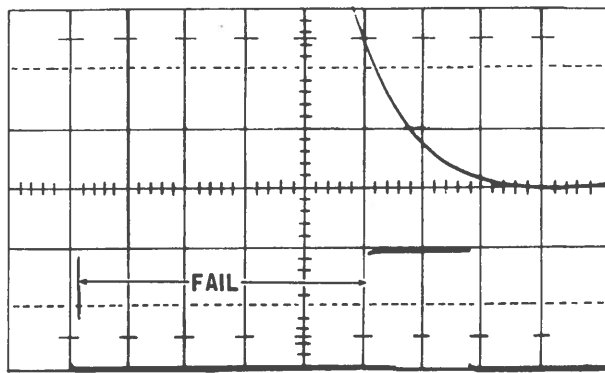

D GAIN TOO LOW

HOR - 1MS/CM
VERT - 0.2V/CM

NOTE: ALL UPPER TRACES TPD A25
ALL LOWER TRACES TPJ A28

7F19

Figure 6-22. Fine Position Gain Adjustment

NOTE

Parts C and D of Figure 6-22 show traces from an improperly adjusted unit.

9. Make trace comparison with Figure 6-22, Part A, for each of the 405 Seek operations.
10. If requirements are met, disconnect oscilloscope; check is complete. If access tester card was used, remove jumper from C30-13A to test point J at A18.
11. If requirements are not met, adjust as follows:
 - a. Command a one track sequential forward seek from track 0.

NOTE

Adjustment of the potentiometer shaft will, to some extent, affect the trace for each Seek operation. Each adjustment of the shaft must be followed by a repeat of the 405 track scan to ensure that some other area is not now failing to meet requirements.

- b. Allow Seeks to occur until requirements are not met, then adjust potentiometer shaft on card at location A25 until requirement is met.
- c. Repeat step 11a.
- d. If requirements are met, disconnect oscilloscope; adjustment is complete. If access tester card was used, remove jumper from C30-13A to test point J at A18.
- e. If requirements are not met, repeat steps 11a through 11c.

INTEGRATOR GAIN CHECK/ADJUSTMENT

1. Open cabinet front cover.
2. Install a disk pack and close front cover.

3. Start unit and allow heads to load.
4. Connect oscilloscope external trigger to test point M ($\overline{T>32}$) at location A27. Set trigger to negative.
5. Connect oscilloscope ground lead to GND jack on logic chassis maintenance panel.
6. Connect oscilloscope probe to test point B (Function Generator) at location A27.

NOTE

In following procedure it is necessary to Command Seek operations. These commands may be derived by either suitable software and the central processor or the access tester card (P/N 54116100) installed in logic chassis (location C30). If Commands are derived from access tester card, set the unit ON LINE/OFF/LINE switch to OFF LINE.

7. Command unit to perform a 64 track repeat seek between tracks 0 and 64.
8. Adjust oscilloscope horizontal sensitivity to obtain one negative and one positive sloped trace (approximately 2 ms/cm). Set vertical sensitivity to 2 v/cm.

NOTE

Velocity integrator functions to fill in (smooth out) the stepped output of the D/A converter. Integrator gain must be adjusted so that function generator output is smoothed out and does not contain points of discontinuity along its slope. Figure 6-23, part C, shows a faulty adjustment.

9. Compare the trace to Figure 6-23, part A. Trace slopes must be smooth and contain no discontinuities.
10. If requirement is met, disconnect oscilloscope; check is complete. If requirement is not met, adjust as follows:
 - a. Set oscilloscope horizontal sensitivity to 1 ms/cm.
 - b. Adjust potentiometer shaft on outer edge of card at location A27 until trace slope is smooth and contains no points of discontinuity.
 - c. Disconnect scope, adjustment is complete.

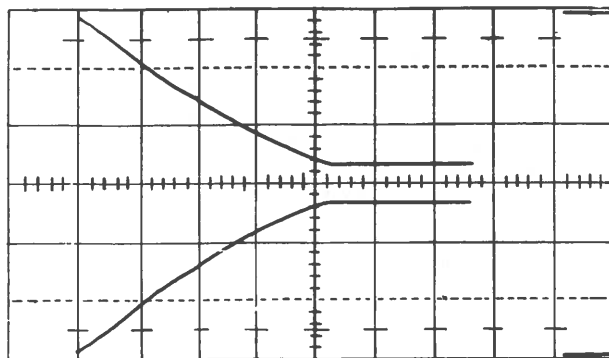

A CORRECT

HOR - 2MS/CM
VERT - 2V/CM

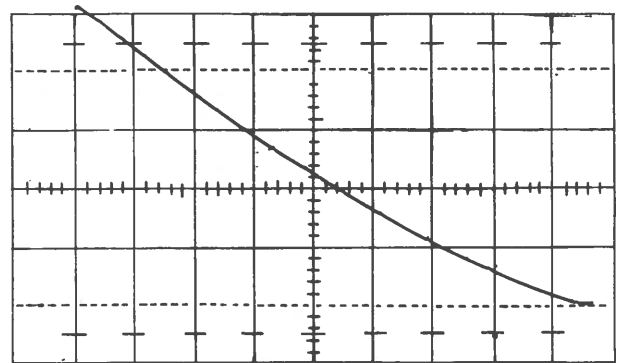

B CORRECT

HOR - 1MS/CM
VERT - 1V/CM

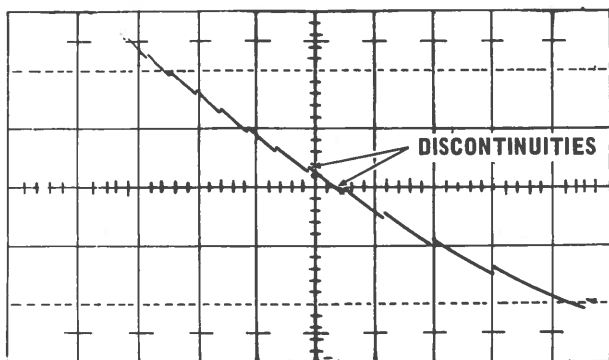

C FAULTY

HOR - 1MS/CM
VERT - 1V/CM

**NOTE: TRACE SHOWS FUNCTION
GENERATOR OUTPUT (TPB, A27)
FOR FORWARD AND REVERSE SEEK**

6T57

Figure 6-23. Integrator Gain Adjustment

SERVO FILTER BALANCE CHECK/ADJUSTMENT

1. Open cabinet front cover.
2. Install a disk pack and close front cover.
3. Start unit and allow heads to load.
4. Open cabinet rear door.
5. Connect oscilloscope external trigger to test point L (Forward) at location A27. Trigger may be set for either positive or negative.
6. Connect oscilloscope channel probe to test point G at location A23.

SECTION 1

REQUIREMENTS

Information for this section is found in BRSA
Bank Storage Unit, Vol. No. 1001-100

SECTION 2

REQUIREMENTS

Information for this section is found in BRSA
Bank Storage Unit, Vol. No. 1001-100

SECTION 3

REQUIREMENTS

Information for this section is found in BRSA
Bank Storage Unit, Vol. No. 1001-100

SECTION 4

REQUIREMENTS

(Not Applicable)

COMMENT SHEET

MANUAL TITLE CONTROL DATA BR2A5 DISK STORAGE UNIT
Customer Engineering Maintenance Manual

PUBLICATION NO. 70614600 REVISION _____

FROM: NAME: _____
BUSINESS ADDRESS: _____

COMMENTS:

This form is not intended to be used as an order blank. Your evaluation of this manual will be welcomed by Control Data Corporation. Any errors, suggested additions or deletions, or general comments may be made below. Please include page number references and fill in publication revision level as shown by the last entry on the Record of Revision page at the front of the manual. Customer engineers are urged to use the TAR.

CUT ALONG LINE

PRINTED IN U.S.A.

AA3419 REV. 11/69

NO POSTAGE STAMP NECESSARY IF MAILED IN U. S. A.

FOLD ON DOTTED LINES AND STAPLE

STAPLE

STAPLE

FOLD

FOLD

FIRST CLASS
PERMIT NO. 8241

MINNEAPOLIS, MINN.

BUSINESS REPLY MAIL

NO POSTAGE STAMP NECESSARY IF MAILED IN U.S.A.

POSTAGE WILL BE PAID BY

CONTROL DATA CORPORATION

Technical Publications Department
7801 Computer Avenue
Minneapolis, MN 55435



CUT ALONG LINE

FOLD

FOLD