

PRODUCT SPECIFICATION
FOR
LARKTM MICRO UNIT
MODEL 9457

COPYRIGHT © 1982
by MAGNETIC PERIPHERALS INC.
ALL RIGHTS RESERVED

Printed in the United States of America

**This publication may contain application, high technology,
or product specification data, or any combination thereof,
is considered advance technical information by the
producer, and is subject to change without prior notice.**

PRODUCT SPECIFICATION
FOR
LARKTM MICRO UNIT
MODEL 9457

		PC A	SPEC. NO. 77711094	SHEET 2	REV. A
--	--	---------	-----------------------	------------	-----------

PRODUCT SPECIFICATION - 9457 Lark Micro Unit

TABLE OF CONTENTS

1.0 SCOPE 5

2.0 APPLICABLE DOCUMENTS 6

 2.1 STANDARDS 6

 2.2 DOCUMENTATION 6

3.0 GENERAL DESCRIPTION 7

4.0 STANDARD FEATURES 8

5.0 PERFORMANCE CHARACTERISTICS 9

 5.1 ACCESS-TO-DATA CHARACTERISTICS 10

 5.1.1 Positioning Time 10

 5.1.2 Spindle Speed and Latency 10

 5.1.3 Read Initialization Time 10

 5.1.4 Write-to-Read Recovery Time 11

 5.1.5 Read-to-Write Recovery Time 11

 5.1.6 Data Capacity 11

 5.1.7 Data Transfer Rate 11

 5.1.8 Start/Stop Time 11

6.0 RELIABILITY SPECIFICATIONS 12

 6.1 ERROR RATES 12

 6.1.1 Read Errors 12

 6.1.2 Write Errors 13

 6.1.3 Seek Errors 13

 6.1.4 Environmental Errors 13

 6.2 RELIABILITY AND SERVICE 13

 6.2.1 Mean Time Between Failure 13

 6.2.2 Preventive Maintenance 14

 6.2.3 Service Life 14

 6.2.4 Installation 14

 6.2.5 Service Tools 14

 6.2.6 Self Test 14

		PC	SPEC. NO.	SHEET	REV.
		A	77711094	3	A

PRODUCT SPECIFICATION - 9457 Lark Micro Unit

TABLE OF CONTENTS (contd.)

7.0	PHYSICAL/ELECTRICAL SPECIFICATIONS	15
7.1	POWER REQUIREMENTS	15
	7.1.1 AC and DC Power Connectors	16
	7.1.2 Command/Data Cable Connectors	20
7.2	MECHANICAL SPECIFICATIONS	21
7.3	OPERATOR CONTROL PANEL	25
7.4	ENVIRONMENTAL LIMITS	26
	7.4.1 Temperature	26
	7.4.2 Relative Humidity	27
	7.4.3 Altitude (Actual or Effective)	27
	7.4.4 Vibration and Shock	27
	7.4.5 Air Cleanliness	29
8.0	MEDIA/RECORDING CHARACTERISTICS	30
8.1	MEDIA CHARACTERISTICS	30
	8.1.1 Cartridge Description	30
	8.1.2 Fixed Media Description	30
8.2	ALLOWABLE MEDIA DEFECTS	32
	8.2.1 LMU Fixed Media	34
	8.2.2 LMU Cartridge Media	34
8.3	RECORDING CHARACTERISTICS	34
8.4	DATA SECURITY	35
9.0	ERROR RECOVERY CONSIDERATIONS	36
9.1	EARLY/LATE DATA STROBE AND CARRIAGE OFFSET	36
9.2	ECC IMPLEMENTATION.....	36

		PC	SPEC. NO.	SHEET	REV.
		A	77711094	4	A

PRODUCT SPECIFICATION - 9457 Lark Micro Unit

TABLE OF CONTENTS (contd.)

10.0 OPTIONAL FEATURES 36

10.1 POWER SUPPLY..... 36

10.2 INTERFACE ADAPTER 44

10.3 COLOR OPTIONS 54

10.4 MICRO COMPUTER STATUS DISPLAY..... 55

11.0 ACCESSORIES..... 56

		PC	SPEC. NO.	SHEET	REV
		A	77711094	5	A

PRODUCT SPECIFICATION - 9457 Lark Micro Unit

1.0 SCOPE

This specification describes the Model 9457 Lark Micro Unit. Within this document the Lark Micro Unit will be referred to as the Disk Storage Unit, LMU, Micro Unit, or simply as the drive. The LMU interface will be referred to as the Lark Device Interface (LDI). The matching network which allows data transfer between the LMU and the user-defined controller will be referred to as the interface adapter.

The LMU consists of the Lark Device Interface, the head positioning mechanism, the read/write electronics, the read/write heads, and the fixed disk.

Optional features are available which include the following:

- Power Supply
- Interface Adapter
- Various Colors
- Micro Computer Status Display
- Cables

The Power Supply is described in Section 10.1 and Interface Adapter in Section 10.2. The optional colors, the status display options and cables are described in Sections 10.2, 10.3 and 10.4 of this specifications.

Various accessories are available which are described in Section 11.0.

The LMU is shown in Figure 1.

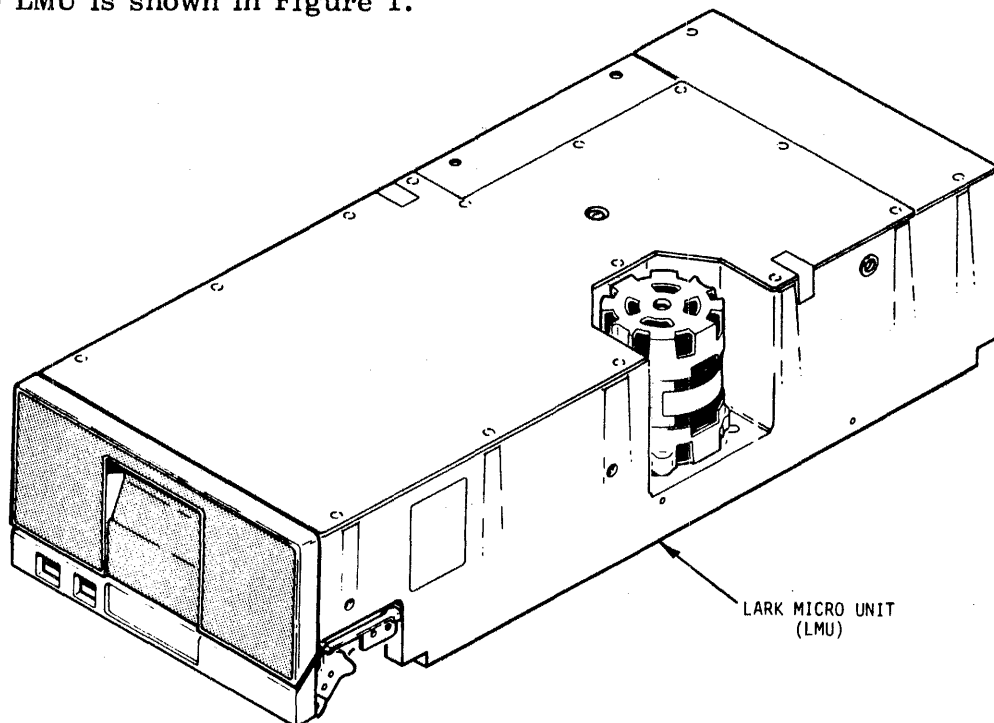

FF019a

Figure 1. Lark Micro Unit

		PC	SPEC. NO.	SHEET	REV.
		A	77711094	6	A

PRODUCT SPECIFICATION - 9457 Lark Micro Unit

1.0 -contd.

The basic configurations of the 9457 are as listed below:

PRODUCT NUMBER	VOLTAGE/ FREQUENCY	MOUNTING	NUMBER OF SECTORS
9457	120/60	Rack Horz/Vert	32
9457	120/60	Rack Horz/Vert	64
9457	220/230/240/50	Rack Horz/Vert	32
9457	220/230/240/50	Rack Horz/Vert	64

2.0 APPLICABLE DOCUMENTS

2.1 STANDARDS

In addition to applicable CDC corporation standards, the LMU complies with the requirements of UL 478 and CSA Standard C22.2 No. 154-1975. The LMU is a component and, as such, is not subject to standards imposed by FCC Docket 20780/FDD 8-148 Part 15 governing EMI of computing devices.

The Model 9457 LMU has been designed as a system peripheral to the highest standards of design and construction. The drive, however, must depend upon its host equipment to receive adequate power and environment in order to provide optimum performance and compliance with applicable industry and governmental regulations. Special attention must be given in the areas of safety, power distribution, grounding, shielding, audible noise control, and temperature regulation of the device to ensure specified performance and compliance with all applicable regulations.

When evaluating systems operation under conditions of EMI the performance of the 9457 Lark Micro Unit within the system shall be considered acceptable if the device does not generate an unrecoverable error, or incur an unrecoverable condition. An unrecoverable error, or condition, is defined as one which:

1. Is not detected and corrected by the device itself;
2. Or is not capable of being detected from the error or fault status provided through the device/system interface;
3. Or is not capable of being recovered by normal device or system recovery procedures without requiring operator intervention.

2.2 DOCUMENTATION

The following documentation is available for field support of the LMU.

- Lark Device Interface, 77653473
- LMU Installation and Operation Manual, 77711044
- LMU Maintenance Manual, 77711050
- CDC Disk Cartridge Product Specification, 64717100
- Voltage Conversion Instructions, TBD

		PC	SPEC. NO.	SHEET	REV.
		A	77711094	7	A

PRODUCT SPECIFICATION - 9457 Lark Micro Unit

3.0 GENERAL DESCRIPTION

The Model 9457 LMU is a member of a family of low-cost, high-performance, highly reliable, random access, rotating disk mass memory devices featuring both removable and fixed media storage.

The media used on the LMU is an extension of the media used with the existing module drive family. The diameter of the disk is approximately eight inches. Its coating thickness is optimized for high density magnetic recording with densities up to 6774 flux reversals per inch and track densities up to 715 tracks per inch.

A dedicated servo surface is not used with the LMU for head positioning control. Instead, embedded servo information is factory written on each data surface in those areas not occupied by header or data blocks. This pre-recorded servo field is used for carriage positioning, index and sector pulse generation, and PLO reference clock.

The basic components in the LMU consists of the base casting, spindle, spindle drive motor, cartridge insertion and positioning mechanism, linear servo motor and carriage assembly with read/write heads, base PWA with microcomputer control, Read Signal Processor PWA, and Read/Write Pre-Amp PWA. A cooling fan is also provided.

These components are shown in Figure 2.

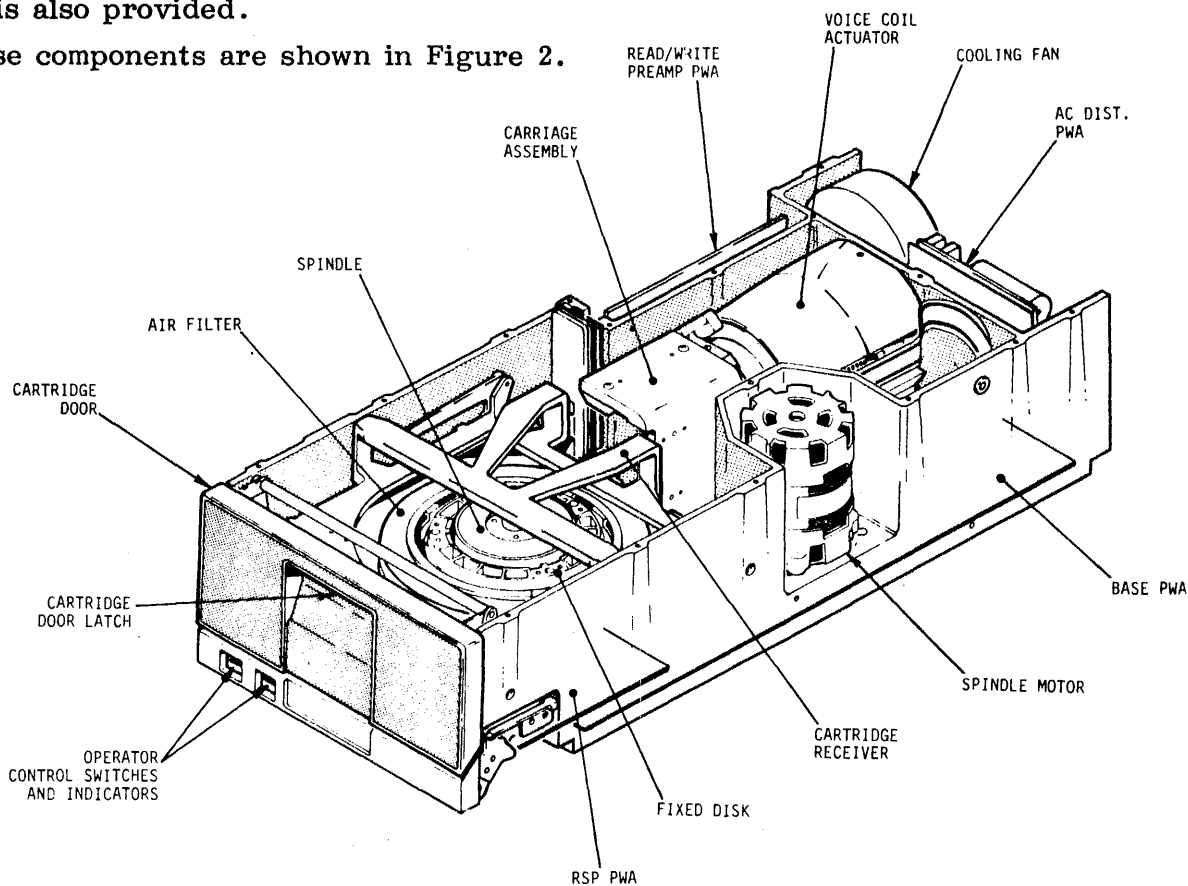

FF018a

Figure 2. LMU Basic Components

		PC	SPEC. NO.	SHEET	REV.
		A	77711094	8	A

PRODUCT SPECIFICATION - 9457 Lark Micro Unit

3.0 -contd.

The unformatted storage capacity of the LMU is 50 megabytes: 25 megabytes of storage is provided by the removable disk (cartridge) and 25 megabytes of storage is provided by the fixed disk. This typically provides 40.8 MB of on-line formatted storage.

For operator convenience, the cartridge is removed and inserted via a hinged access door on the front panel that locks when the disks begin to spin. Operator controls (and indicators) consist of a START/STOP switch and a WRITE PROTECT switch for the fixed disk. An optional status display is also available. The front panel and cartridge insertion are shown in Figures 9 and 13.

The LMU utilizes an asynchronous bus interface which allows flexibility in the adapter design. The bus timing and protocol is controlled by a microcomputer within the LMU to also provide maximum flexibility and expandability of the interface for future product enhancements. Bus timing requirements (that is, setup times, hold times, response times, etc.) have been defined to require minimal hardware within the adapter. These timing requirements also allow a wide range of technologies (such as MOS, LSI, TTL, and/or microcomputers) to be used to implement an adapter design.

The physical interface consists of a 40-pin command ("C") cable and a 26-pin data ("D") cable. The command cable can be daisy-chained and is based on an 8-bit bidirectional bus for command/status transfer between the adapter and the drive.

NOTE

The user must provide the daisy-chain facilities; only one command I/O connector is provided on the LMU.

A maximum of four LMU's may be daisy-chained. The data cable, which contains high frequency (9.67 MHz) read/write signals, must be radially connected. Cabling is discussed in more detail in the Lark Device Interface Specification, 77653473.

4.0 STANDARD FEATURES

The LMU has the following standard features:

- Removable Cartridge
- Low Power Consumption
- 32 or 64 Hard Sector Configurations
- Early/Late Data Strobing
- Carriage Offset FWD/REV
- Internal Fault Monitoring
- No Electrical Adjustments Required
- No Head Alignment Required
- Embedded Servo
- LSI and Microcomputer Control
- Low Audible Noise for Office Environments
- Lark Device Interface (LDI)
- Independent Manual Write Protect on Fixed and/or Cartridge Media
- Re-Circulating Air Filtration System
- Horizontal or Vertical Mounting
- Read only feature of Model 1208-8 MB Cartridge
- Self Test Capability

		PC	SPEC. NO.	SHEET	REV.
		A	77711094	9	A

PRODUCT SPECIFICATION - 9457 Lark Micro Unit

5.0 PERFORMANCE CHARACTERISTICS

The performance characteristics of the LMU are shown in Table 1.

Table 1. Performance Characteristics

Data Capacity (Unformatted) (Note 1)	
Per Track	20,672 bytes
Per Removable Cartridge	25 megabytes
Per Fixed Disk	25 megabytes
Total	50 megabytes
Number of Data Heads	4
Per Removable Cartridge	2
Per fixed Disk	2
Recording Mode	2,9
Data Interface	NRZ DATA + CLOCK
Flux Reversal Density	6774 FRI / 10,161 BPI
Track Density	715 TPI
No. Tracks/Surface	624
Data Transfer Rate (Nominal)	9.677 MHz
Maximum Latency	17.95 ms
Average Latency	8.55 ms
Positioning Times	
Average	35 ms
Maximum	80 ms
Single Track	10 ms

NOTE 1: Formatted capacity realized in a specific system application is generally less than the inherent capacity and may be different for the same LMU on different systems.

		PC	SPEC. NO.	SHEET	REV.
		A	77711094	10	A

PRODUCT SPECIFICATION - 9457 Lark Micro Unit

5.1 ACCESS-TO-DATA CHARACTERISTICS

5.1.1 Positioning Times

Positioning time is defined as the time required from the receipt of a seek and/or head change command by the LMU until the drive signals the controller it is ready to perform another seek or read/write function on the new cylinder. Completion of a seek is reported by the interface with a status return. Because the LMU incorporates positioning information on each of its four data surfaces, a head change, whether to the current cylinder address or to a new one, is also considered as a positioning time.

Average seek time is determined by dividing the sum of all possible movements by the total number of movements.

The positioning times are listed below:

Maximum Positioning Time	80 ms
Average Positioning Time Without Head Change	35 ms
Average Maximum Adjacent Single Track Seeks Without Head Change	10 ms
Average Maximum Random Head Selection Without Seek Command	10 ms
Average Maximum Random Head Selection With One Track Adjacent Seeks	15 ms
Seek to Same Cylinder Address and Head	≤2 ms
Return to Zero (Maximum)	500 ms

5.1.2 Spindle Speed and Latency

The spindle speed is 3510 +3.0, -4.8% revolutions per minute (r/min). The speed tolerance includes motor performance, belt and pulley tolerances and the mains voltage and frequency variations specified in Section 7.1. This does not include other variables which affect data transfer rates.

The average latency time is 8.55 milliseconds, based on a nominal disk speed of 3510 r/min. The maximum latency time is 17.95 milliseconds based on a minimum disk speed of 3342 r/min (3510 -4.8%).

Latency time is defined as the time required to reach a particular sector after positioning is complete.

5.1.3 Read Initialization Time

Read Initialization time is defined as the time required to switch from one head to another, stabilize the read circuitry, and establish phase lock oscillator synchronization subsequent to reading data. This time is 10 milliseconds average maximum assuming a head change to the current cylinder address.

		PC	SPEC. NO.	SHEET	REV.
		A	77711094	11	A

PRODUCT SPECIFICATION - 9457 Lark Micro Unit

5.1.4 Write-to-Read Recovery Time

Assuming a write operation is in progress the required time interval between the end of Write Gate and the initiation of Read Gate is 10 microseconds minimum.

5.1.5 Read-to-Write Recovery Time

Assuming a read operation is in progress, the required minimum time interval between the end of Read Gate and the initiation of Write Gate is 0.3 microseconds.

5.1.6 Data Capacity

The total unformatted data capacity of the LMU is 51,597,312 bytes per spindle. The total formatted data capacity using the recommended format is 40,843,264 bytes per spindle. This capacity does not include defective sectors.

Formatted capacity realized in a specific system application is generally less than the inherent capacity and may be different for the same LMU in different systems.

5.1.7 Data Transfer Rate

The nominal serial data transfer rate is 9,676,800 bits per second (1.2096 megabytes per second). The range of transfer rate variations on a byte-per-second basis for read/write operations is +5.0, -5.5% of the nominal. This range includes the effects of all factors including spindle speed variations and dynamic jitter on a byte-to-byte basis. Data on the interface is NRZ while the drive internally converts this information to a 2,9 code for reading and writing.

5.1.8 Start/Stop Time

Assuming that a cartridge has been inserted in the drive and no faults are present, the maximum time measured from actuation of start switch to Ready and On Cylinder status to adapter is 120 seconds.

The maximum stop time measured from actuation of stop switch until the cartridge can be removed is 60 seconds.

Upon a power loss, the maximum stop time is 120 seconds.

		PC	SPEC. NO.	SHEET	REV.
		A	77711094	12	A

PRODUCT SPECIFICATION - 9457 Lark Micro Unit

6.0 RELIABILITY SPECIFICATIONS

The following reliability specifications assume correct host/drive operational interface has been implemented, including all interface timings, power supply voltages, environmental conditions, and appropriate data-handling circuits in the host system.

Error Rates

Soft Read Errors (Recoverable) 1 in 10^{10} bits read

Hard Read Errors (Unrecoverable) 1 in 10^{12} bits read

Seek Errors 1 in 10^6 seeks

MTBF 7500 hours

Service Life 5 years or 20,000 hours

Preventive Maintenance None required

6.1 ERROR RATES

The error rates stated in paragraph 6.0 assume the following:

1. That the LMU is operated per specification.
2. That an approved data cartridge is employed.
3. That a data format is employed fulfilling the requirements of the LMU as outlined in the Lark Device Interface Specification, 77653473.
4. That errors caused by media defects or host system failures are excluded from error rate computations.
5. That power requirements as specified in paragraph 7.1 and system grounding requirements indicated in the installation instructions are met.

6.1.1 Read Errors

Prior to the determination of measurement of read error rates:

1. The data which is to be used for a measurement of read error rates must be verified as being written correctly on the media.
2. All media defect induced errors must be excluded from error rate calculations.

A Recoverable Read Error is one that can be re-read correctly in 27 or less retries. These retries must include all combinations of Data Strokes and carriage offsets.

		PC	SPEC. NO.	SHEET	REV.
		A	77711094	13	A

PRODUCT SPECIFICATION - 9457 Lark Micro Unit

6.1.1 -contd.

The recoverable read error rate for any read operation shall be less than one error in 10^{10} bits read.

An unrecoverable read error is one which cannot be read correctly after 27 retries to read the record. These retries must include all combinations of data storbes and carriage offsets.

The unrecoverable read error rate shall be less than one bit in 10^{12} bits read.

6.1.2 Write Errors

Write errors can occur as a result of the following: write data not being presented correctly, media defects, environmental interference, or equipment malfunction. As such, write errors are not predictable as a function of the number of bits passed.

If an unrecoverable write error occurs because of an LMU equipment malfunction, the error is classified as a failure affecting MTBF. Unrecoverable write errors are those which cannot be corrected within three attempts at writing the record with a write verify after each attempt.

6.1.3 Seek Errors

A seek error is defined as a condition where the LMU fails to position the heads to the addressed track provided the correct cylinder address information has been presented to the drive. There shall be no more than one recoverable seek error in 10^6 physical seek operations. Unrecoverable seek errors are classified as failures for MTBF calculations.

6.1.4 Environmental Errors

When operating at low effective data transfer rate (that is, random access of single short records), the effective error rate may be expected to exceed the specified limits due to environmental interference. Excluding environmental interference, the recoverable read error rate shall be no more than one error in eight hours of operation.

6.2 RELIABILITY AND SERVICE

6.2.1 Mean Time Between Failure

Following an initial period of 200 hours, the Mean Time Between Failure (MTBF) shall exceed 3200 hours for units manufactured in the first year of production and 6000 hours for units manufactured in the second year. For units manufactured after the second year, the MTBF shall exceed 7500 hours. The following equation defines MTBF:

$$MTBF = \frac{\text{Operating Hours}}{\text{Number of Equipment Failures}}$$

		PC	SPEC. NO.	SHEET	REV.
		A	77711094	14	A

PRODUCT SPECIFICATION - 9457 Lark Micro Unit

6.2.1 -contd.

"Operating Hours" means total power-on hours less any maintenance time.

"Equipment Failures" means any stoppage or substandard performance of the equipment because of equipment malfunction, excluding stoppages or substandard performance caused by operator error, adverse environment, power failure, adapter failure, cable failure, or other failure not caused by equipment. To establish a meaningful MTBF, operation hours must be greater than 7500 hours per drive and shall include field performance data from all field sites.

The term "equipment failure" implies that emergency maintenance is required because of a hardware failure.

6.2.2 Preventive Maintenance

No routine scheduled preventive maintenance shall be required provided the drive is operated in a clean office or computer room environment.

6.2.3 Service Life

The LMU shall have a useful service life of five years or 20,000 power-on hours, whichever occurs first, before requiring factory overhaul. Depot repair or replacement of major parts will be permitted during the lifetime of the drive.

6.2.4 Installation

The LMU is designed, manufactured, and tested with a "Plug-in and Play" installation philosophy. Basically, this philosophy minimizes the requirements for a highly trained personnel to integrate an LMU into the user's system.

The LMU has a factory installed top cover providing maximum protection from environmental contaminants. This cover should only be removed in a recommended maintenance facility with proper environmental control; otherwise, warranty will be void.

This does not preclude on-site replacement of components external to the sealed area such as printed circuit boards, belt, etc.

Required connections to the drive are power, signal cables, and a system ground consistent with normal peripheral equipment grounding practices. The physical requirements are adequate clearance for maintenance and air intake/exhaust.

6.2.5 Service Tools

No special tools are required for site installation or site maintenance of the LMU.

6.2.6 Self Test

On Power application the Micro Processor executes a limited self test routine. After the heads are loaded the Micro Processor continues self test by adjusting the velocity feedback and verifying the general operation of the positioning system.

		PC	SPEC. NO.	SHEET	REV.
		A	77711094	15	A

PRODUCT SPECIFICATION - 9457 Lark Micro Unit

7.0 PHYSICAL/ELECTRICAL SPECIFICATIONS

7.1 POWER REQUIREMENTS

The primary AC/DC voltage and current requirements are shown in Table 2.

Two standard as-shipped voltage configurations are available for the LMU: either 120 V ac 60 Hz or 220 V ac 50 Hz. The 50 Hz configuration will function over the voltage range of 220/230/240 volts without any changes to the LMU. Field conversion of 50/60 Hz LMU's is possible by following the instructions contained in the Voltage Conversion Instructions, TBD.

Table 2. LMU Current/Power Requirements Under Various Conditions

INPUTS	CURRENTS AND WATTAGE					
	ON TRACK		SEEKING		STARTING	
	NOMINAL	MAXIMUM	NOMINAL	MAXIMUM	NOMINAL	MAXIMUM
DRIVE INPUTS:						
120 VAC	0.7 A (60 W)	0.8 A (75 W)	0.7 A (60 W)	0.8 A (75 W)	1.6 A (190 W)	2.0 A (240 W)
220-240 V	0.35 A (60 W)	0.4 A (80 W)	0.35 A (60 W)	0.4 A (80 W)	0.8 A (190 W)	1.0 A (240 W)
+16.5 V	0.4 A (6.6 W)	┌ NOTE	0.72 A (11.9 W)	┌ NOTE	---	---
-16.5 V	0.35 A (5.8 W)	└ NOTE	0.67 A (11.1 W)	└ NOTE	---	---
*+5 V	1.4 A (7.0 W)	1.8 A (9.0 W)	1.4 A (7.0 W)	1.8 A (9.0 W)	---	---
-5.2 V	2.88 A (15.0 W)	3.25 A (16.9 W)	2.88 A (15.0 W)	3.25 A (16.9 W)	---	---
TOTAL WATTAGE	94.4 W	98.3 W	105 W	108.9 W	---	---

*INCLUDES OPTIONAL MC STATUS DISPLAY (300 mA NOMINAL) AND DOES NOT INCLUDE OPTIONAL INTERFACE ADAPTER PWA. REFERENCE SECTION 10.2.

IT IS SUGGESTED A USER SUPPLIED POWER SOURCE HAVE THOSE CHARACTERISTICS LISTED IN TABLE 3.

NOTE 1: Peak Currents from the ±16.5 V source may reach 2.4 amperes for 24 milliseconds duration from either voltage supply (not both) with a 38 millisecond minimum interval between consecutive pulses.

NOTE 2: In regard to DC power sequencing, the +5 VDC supply must not precede the remaining DC voltages in excess of 50 milliseconds.

		PC	SPEC. NO.	SHEET	REV.
		A	77711094	16	A

PRODUCT SPECIFICATION - 9457 Lark Micro Unit

7.1.1 AC and DC Power Connectors

Refer to Figure 3 for connector locations and Table 4 for pin assignments.

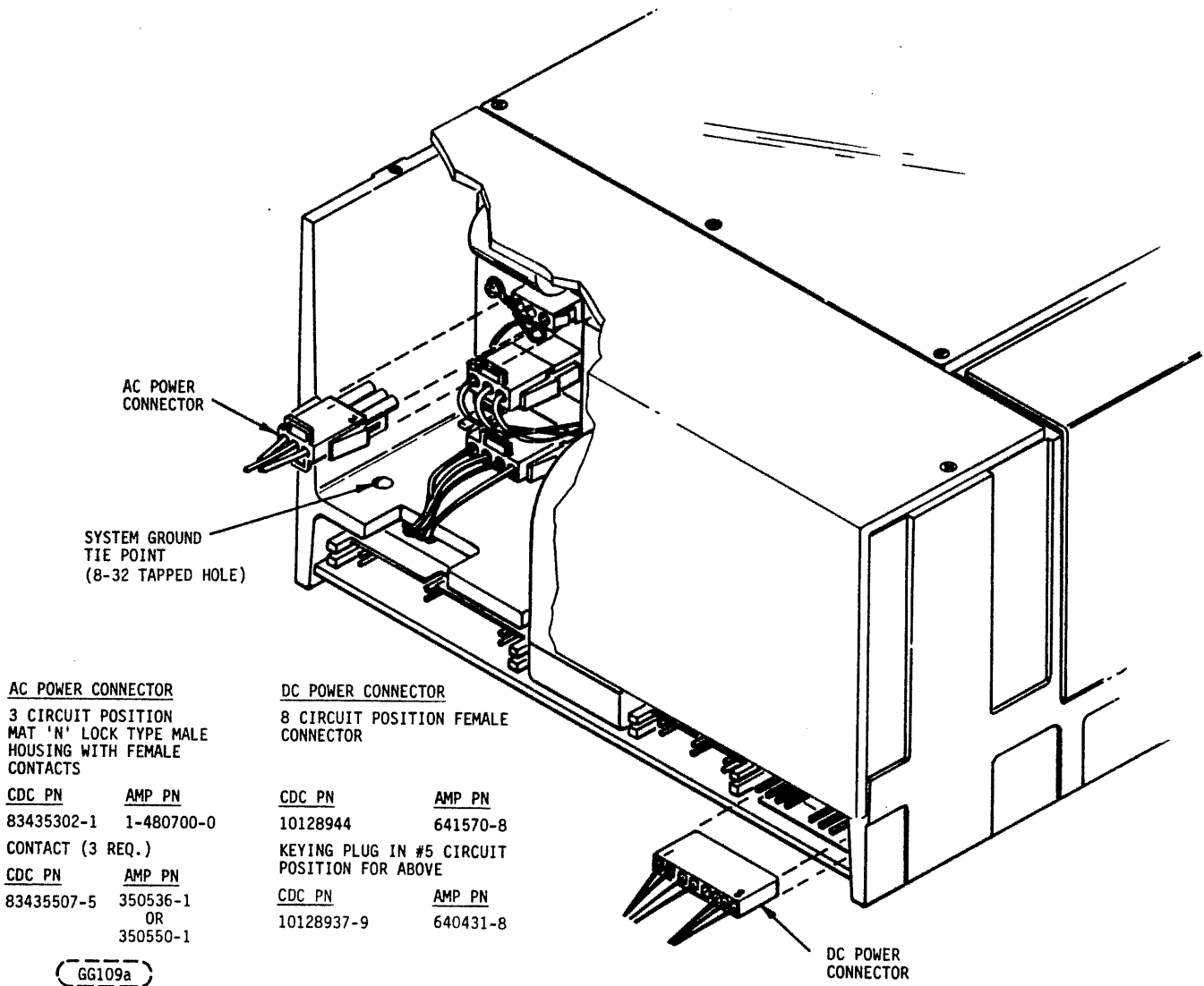

Figure 3. AC and DC Cabling

		PC	SPEC. NO.	SHEET	REV.
		A	77711094	17	A

PRODUCT SPECIFICATION - 9457 Lark Micro Unit

7.1.1 -contd.

Table 3. Recommended LMU Power Source Capability

VOLTAGE (V ac)	TOLERANCE (V ac)	FREQUENCY (Hz)	TOLERANCE (Hz)	
120	+8, -16	60	+0.6, -1.0	
220	+15, -29	50	+0.5, -1.0	
230	+16, -32	50	+0.5, -1.0	
240	+16, -32	50	+0.5, -1.0	

VOLTAGE (V dc)	REGULATION	MAX RIPPLE P/P	CURRENT DRAIN	
			MIN	MAX
+5	±2%	50 mV	0.05 A	2.8 A
-5.2	±2%	50 mV	0.07 A	3.5 A
+16.5	±10%	500 mV	0.1 A	1.3 A
-16.5	±10%	500 mV	0.04 A	1.3 A

NOTE 1: PEAK CURRENT FOR THE ±16.5 VOLT SUPPLIES MAY REACH 2.4 AMPERES FOR 24 MILLISECONDS DURATION FROM EITHER SUPPLY (NOT BOTH) WITH A 38 MILLISECOND MINIMUM INTERVAL BETWEEN CURRENT PULSES

NOTE 2: THE ±5 VOLTS SHALL SHARE A DC COMMON. THE ±16.5 VOLTS SHALL SHARE A SEPARATE DC COMMON.

NOTE 3: IN REGARD TO DC POWER SEQUENCING, THE +5 V DC SUPPLY MUST NOT PRECEDE THE REMAINING DC VOLTAGES IN EXCESS OF 50 MILLISECONDS.

NOTE 4: IT IS RECOMMENDED THE DC POWER SOURCE BE CAPABLE OF SUPPLYING THE MAXIMUM CURRENTS LISTED.

		PC	SPEC. NO.	SHEET	REV.
		A	77711094	18	A

PRODUCT SPECIFICATION - 9457 Lark Micro Unit

7.1.1 -contd.

Table 4. AC/DC Pin Assignments

AC CONNECTOR		DC CONNECTOR	
PIN	SIGNAL	PIN	SIGNAL
1	AC RETURN	1	+16.5 V
2	SAFETY GROUND	2	+5 V
3	AC LINE	3	GROUND
		4	GROUND
		5	KEY
		6	-5.2 V
		7	-5.2 V
		8	-16.5 V

Figure 4 illustrates an operational profile of line currents to power supply versus time.

		PC	SPEC. NO.	SHEET	REV.
		A	77711094	19	A

PRODUCT SPECIFICATION - 9457 Lark Micro Unit

7.1.1 -contd.

- T1 = BREAKER ON
- T2 = DOOR SOLENOID
- T3 = SPINDLE START
- T4 = UP TO SPEED
- T5 = HEAD LOAD
- T6 = AVERAGE SEEK
- T7 = STOP SEEK
- T8 = PUSH/STOP (RETRACT)
- T9 = SPINDLE BRAKE
- T10 = SPINDLE BRAKE OFF
- T11 = BREAKER OFF

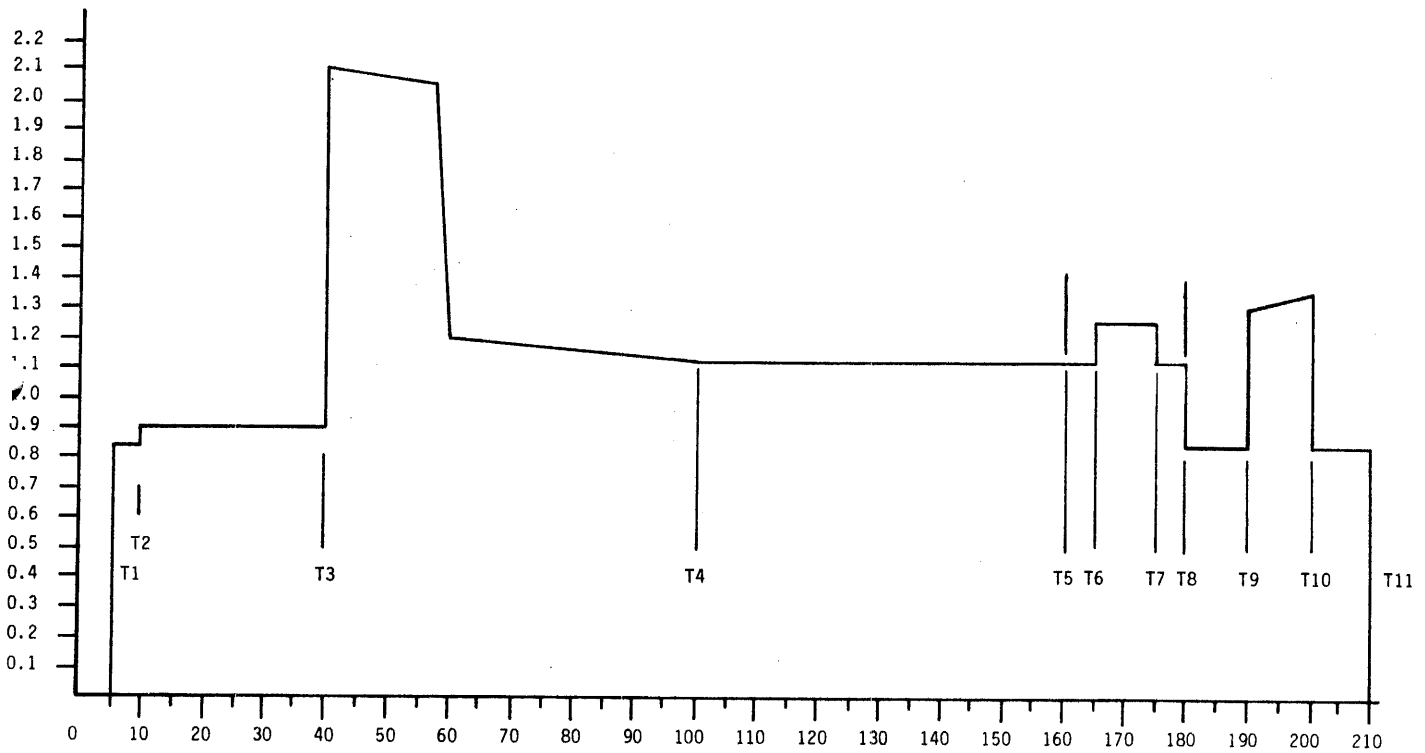

FF052

Figure 4. Operational Nominal Line Currents to Power Supply vs Time

		PC	SPEC. NO.	SHEET	REV.
		A	77711094	20	A

PRODUCT SPECIFICATION - 9457 Lark Micro Unit

7.1.2 Command/Data Cable Connectors

System command/data cable connectors are shown in Figure 5. Detailed connector information is contained in the Product Specification for the Lark Device Interface, 77653473.

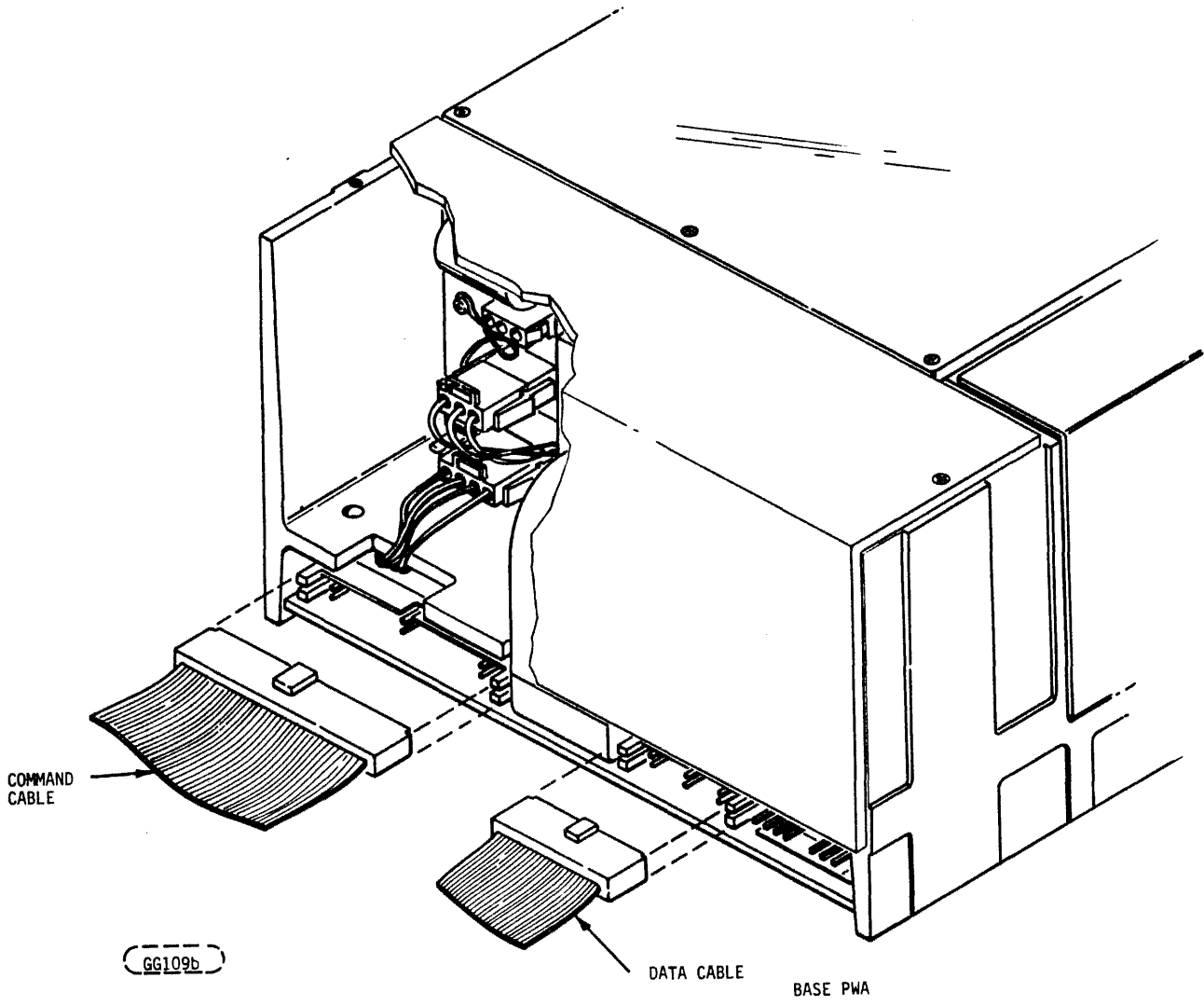

Figure 5. Command/Data Cable Connections

		PC	SPEC. NO.	SHEET	REV.
		A	77711094	21	A

PRODUCT SPECIFICATION - 9457 Lark Micro Unit

7.2 MECHANICAL SPECIFICATIONS

The overall dimensions of the LMU are contained in Figure 6.

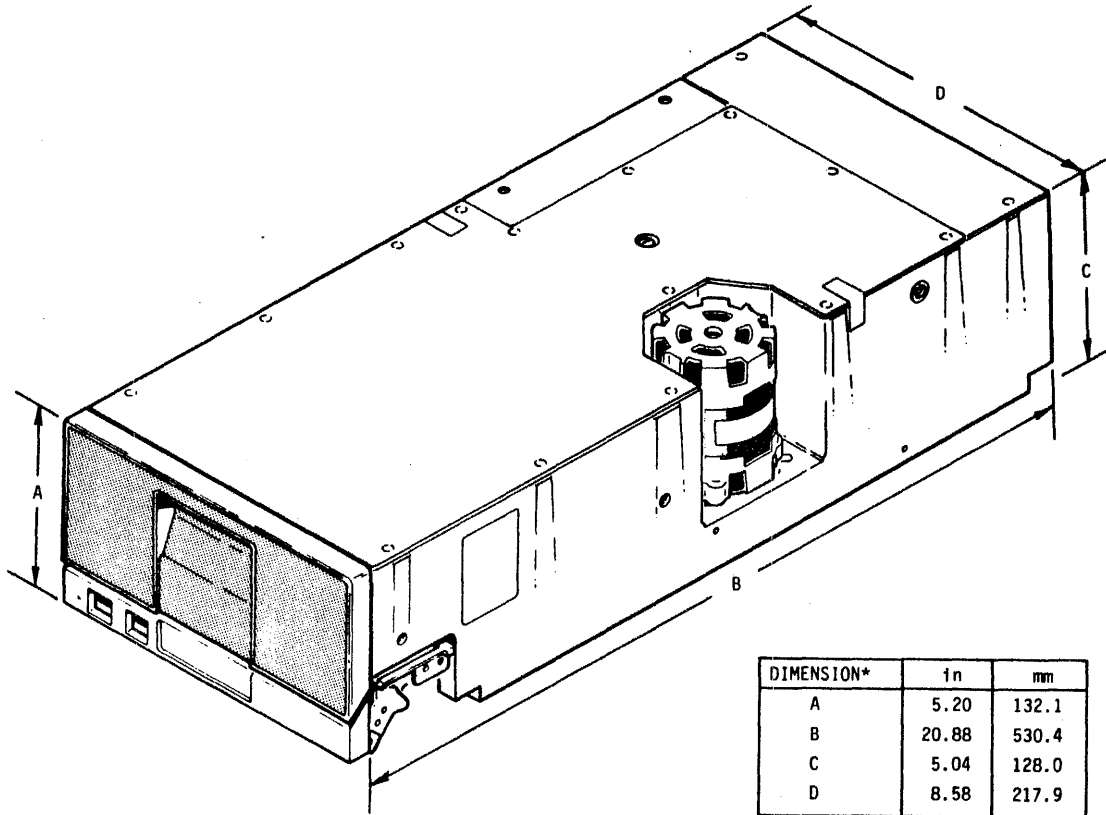

DIMENSION*	in	mm
A	5.20	132.1
B	20.88	530.4
C	5.04	128.0
D	8.58	217.9

WEIGHT - 40 LBS (18 kg)

* MAX DIMENSIONS

EF018b

Figure 6. Mechanical Dimensions

Figure 7 contains detailed mounting configuration dimensions.

		PC	SPEC. NO.	SHEET	REV.
		A	77711094	22	A

PRODUCT SPECIFICATION - 9457 Lark Micro Unit

7.2 -contd.

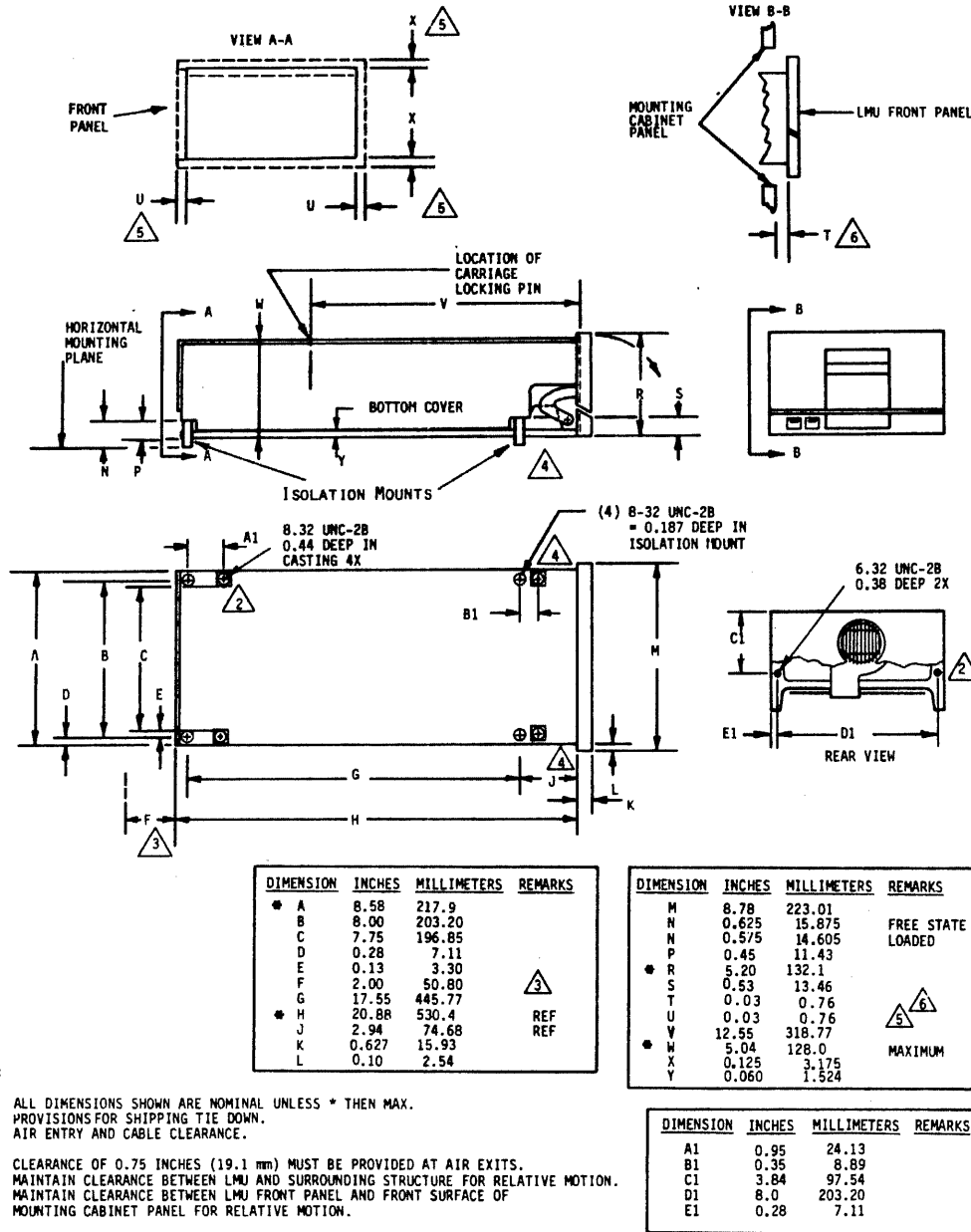

GG039a

Figure 7. Horizontal Mounting Dimensions

		PC A	SPEC. NO. 77711094	SHEET 23	REV. A
--	--	---------	-----------------------	-------------	-----------

PRODUCT SPECIFICATION - 9457 Lark Micro Unit

7.2 -contd.

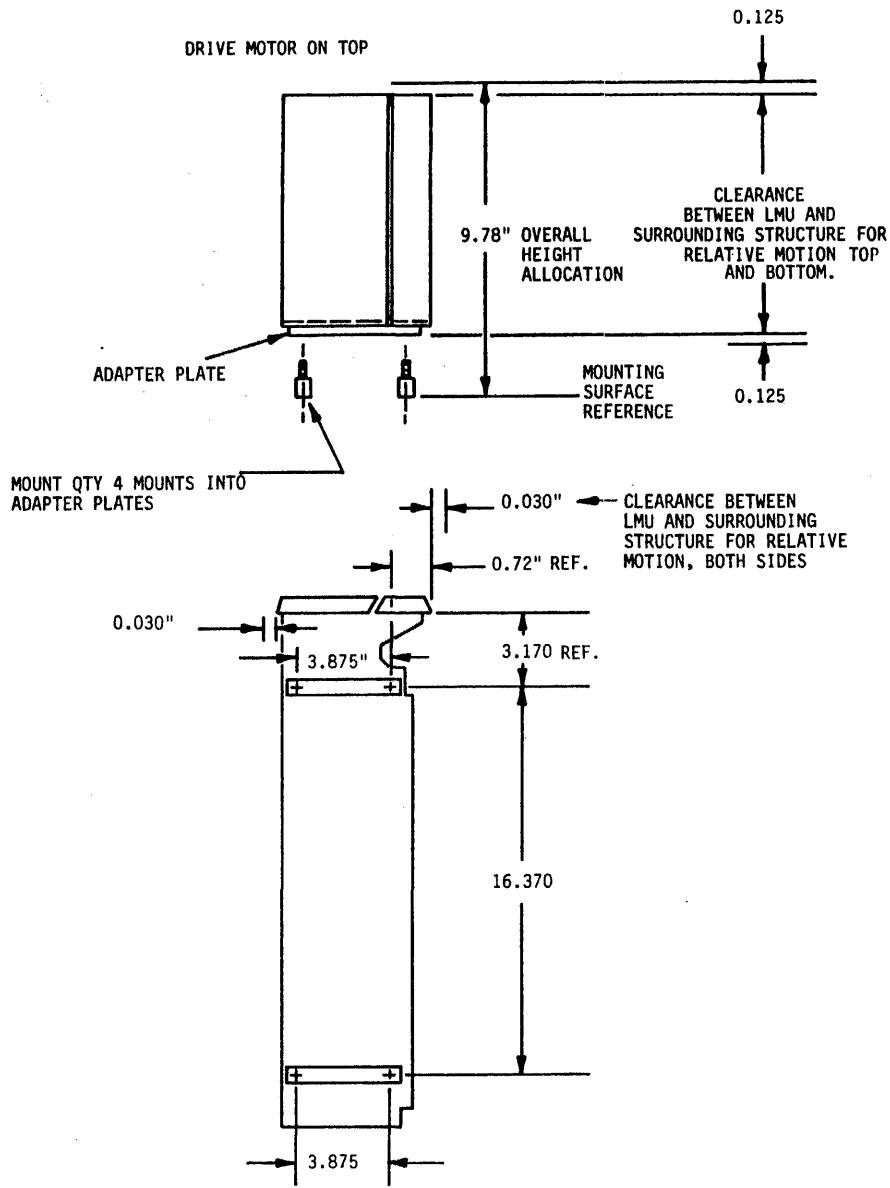

GG242a

Figure 7a. Vertical Mounting Dimension

		PC	SPEC. NO.	SHEET	REV.
		A	77711094	24	A

PRODUCT SPECIFICATION - 9457 Lark Micro Unit

7.2 -contd.

The LMU is designed for installation into a standard RETMA rack or equivalent enclosure. Two LMU's, configured horizontally, will fit within a standard 7.0 inch (177.8 mm) opening. Three drives configured vertically (spindle motor up) will fit within a standard 10.5 inch (266.8 mm) opening. Refer to Figure 8.

No slides are provided with the LMU, but provisions for mounting are found on the side of the base casting for vertical configurations and at the bottom of the base casting for horizontal configurations. The mechanical interface for mounting is accomplished via the mandatory use of shock absorbers supplied with the drive. Reference Figures 7 and 7a for details.

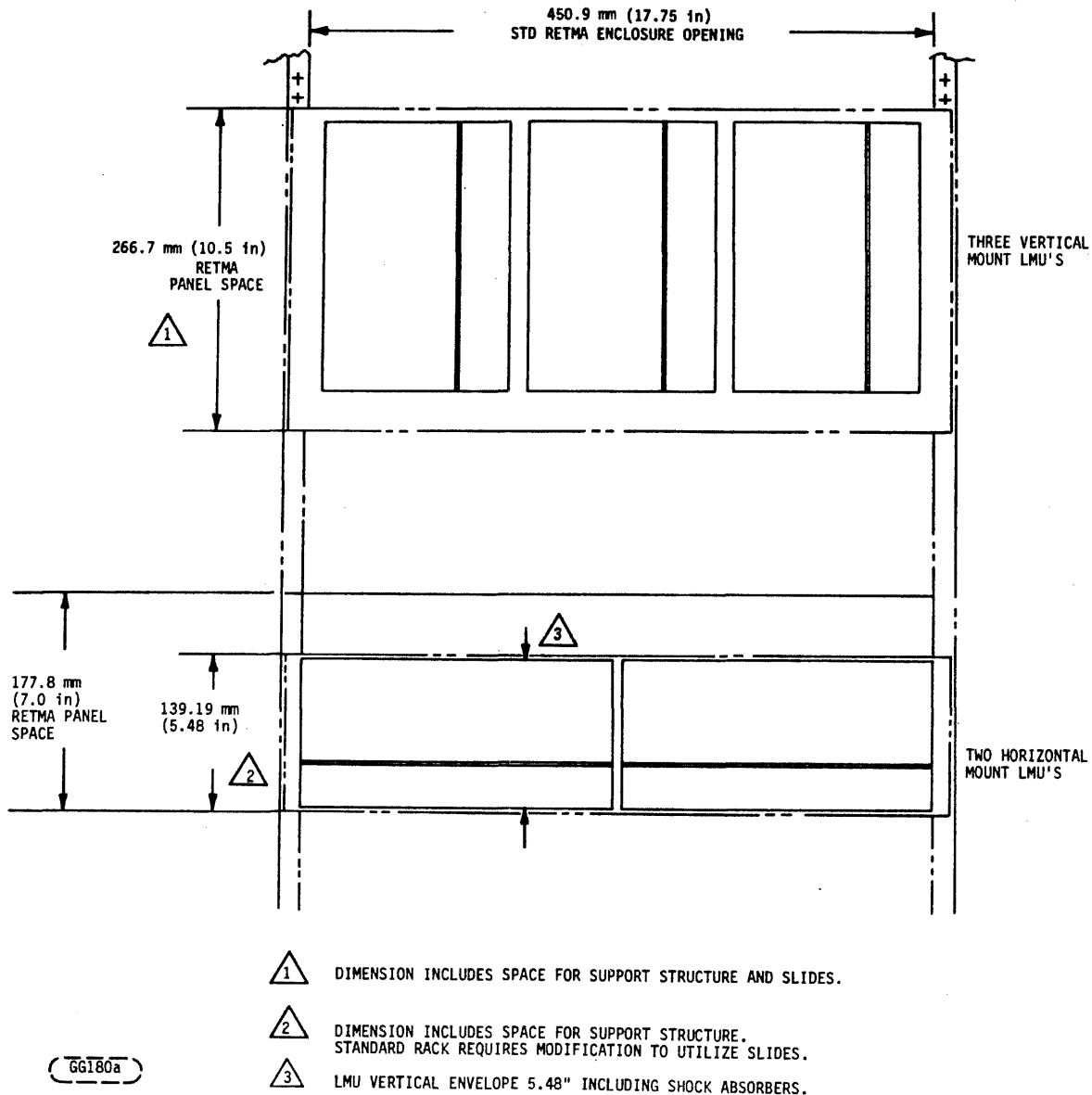

Figure 8. Typical Rack Mount Configurations

		PC	SPEC. NO.	SHEET	REV.
		A	77711094	25	A

PRODUCT SPECIFICATION - 9457 Lark Micro Unit

7.3 OPERATOR CONTROL PANEL

The operator control panel shown in Figure 9 contains two alternate action switches and two LED indicators as defined below.

The Ready indicator illuminates the faceplate of the Start/Stop switch and the Fixed Write Protect indicator illuminates the faceplate of the Fixed Write Protect switch.

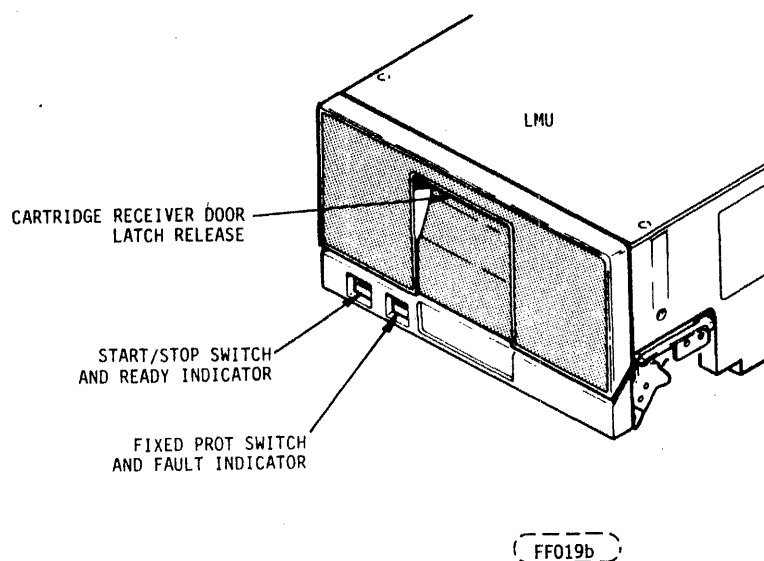

Figure 9. LMU Front Panel

Start/Stop Switch

The Start/Stop switch, when engaged, energizes the spindle motor provided that the following have been satisfied:

1. The AC circuit breaker is ON.
2. The cartridge-door-closed switch is ON.
3. The cartridge-in-place switch is ON.
4. The spindle power off bit has not been activated via an interface command.

Fixed Write Protect Switch

When the Fixed Write Protect Switch is engaged, it inhibits all write operations on the fixed volume. (The removable volume is protected via an operator changeable write protect tab which is sensed by the LMU electronics to prevent unwanted writing.) This switch also provides a means for the operator to clear device faults. When a fault condition exists, cycling the switch from its current position and then back initiates the fault reset and recovery procedure.

		PC	SPEC. NO.	SHEET	REV.
		A	77711094	26	A

PRODUCT SPECIFICATION - 9457 Lark Micro Unit

7.3 -contd.

Ready Indicator

The Ready indicator indicates Unit Ready status whenever the spindle is up to speed and the heads are loaded. The Ready indicator blinks during the spindle start and stop procedures.

Fixed Write Protect Indicator

The Fixed Write Protect Indicator indicates that the selected volume is write protected. In addition, it also provides the operator with fault status as follows:

1. Fixed Write Protect indicator blinking indicates that a fault condition has been detected.
2. Fixed Write Protect indicator blinking with the Ready indicator OFF indicates a fault causing the heads to retract.

Micro-Computer Status Display (Optional)

This option is available to allow display of Micro-computer status codes as an aid to fault diagnosis. Reference Section 10.4.

7.4 ENVIRONMENTAL LIMITS

The LMU is intended to operate in computer room and office environments with minimal environmental control. Temperature and humidity specifications preclude condensation on any drive parts.

7.4.1 Temperature

1. Operating

50° F to 104° F (10° C to 40° C) with a maximum gradient of 18° F (10° C) per hour. The maximum temperature of 104° F (40° C) applies at altitudes between ±983 feet (300 meters) or atmospheric pressures between ±105 kilopascals. Above this altitude, the maximum temperature is derated linearly to 95° F (35° C) at 6560 feet (2000 meters), or atmospheric pressure of 79.5 kilopascals.

2. Transit Temperatures

-40° F to 140° F (-40.4° C to 60° C) with a maximum gradient of 36° F (20° C) per hour. This specification assumes that the drive is packaged in the shipping container designed for use with the LMU.

3. Storage Temperature

+14° F to 122° F (-10° C to 50° C) with a maximum gradient of 27° F (15° C) per hour.

If it becomes necessary to use an LMU cartridge which has not been allowed to stabilize at the ambient drive operating room temperature for at least one hour or if the cartridge was exposed to temperatures below 61° F (16° C) immediately prior to the stabilization period, then the following procedures must be employed:

		PC	SPEC. NO.	SHEET	REV.
		A	77711094	27	A

PRODUCT SPECIFICATION - 9457 Lark Micro Unit

7.4.1 -contd.

1. The cartridge must be visually inspected or examined to ensure that condensation is not present on any part of the cartridge.
2. The cartridge must be allowed to spin on the LMU for a period of not less than five minutes prior to attempting to read or write on the cartridge.

7.4.2 Relative Humidity

1. Operating
20% to 80% relative humidity with a maximum gradient of 10% per hour.
2. Transit (packaged in the shipping container designed for use with the LMU)
5% to 95% relative humidity.
3. Storage
10% to 90% relative humidity.

7.4.3 Altitude (Actual or Effective)

1. Operating
-983 to +6560 feet (-300 to +2000 meters), sea level reference.
2. Transit (packaged in the shipping container designed for use with the LMU)
-983 to +8200 feet (-300 to +2500 meters), sea level reference.
The LMU, in its shipping container, can be shipped via commercial airlines.

7.4.4 Vibration and Shock

The LMU is designed to withstand the vibration and shock conditions specified below without damage to its function, physical structure, or external appearance as measured at mounting interface.

NOTE

If the drive is installed in an enclosure to which the stated shock/vibration criteria is applied, resonances may occur internally to the enclosure resulting in forces in excess of these limits at the installed drive's interface. Shock absorbers are supplied with the drive and are to be used in both the vertical and horizontal mounting configurations.

1. Equipment, as normally installed and positioned, shall meet the full specified performance while subject to the following conditions injected to the isolation mounts in a vertical direction.

		PC	SPEC. NO.	SHEET	REV.
		A	77711094	28	A

PRODUCT SPECIFICATION - 9457 Lark Micro Unit

7.4.4 -contd.

- a. Continuous vibration as indicated in Figure 10, Curve A (Operating).
- b. Intermittent shocks of up to 2 g and not exceed 10 milliseconds in duration. No shock is to be repeated more often than two per second.

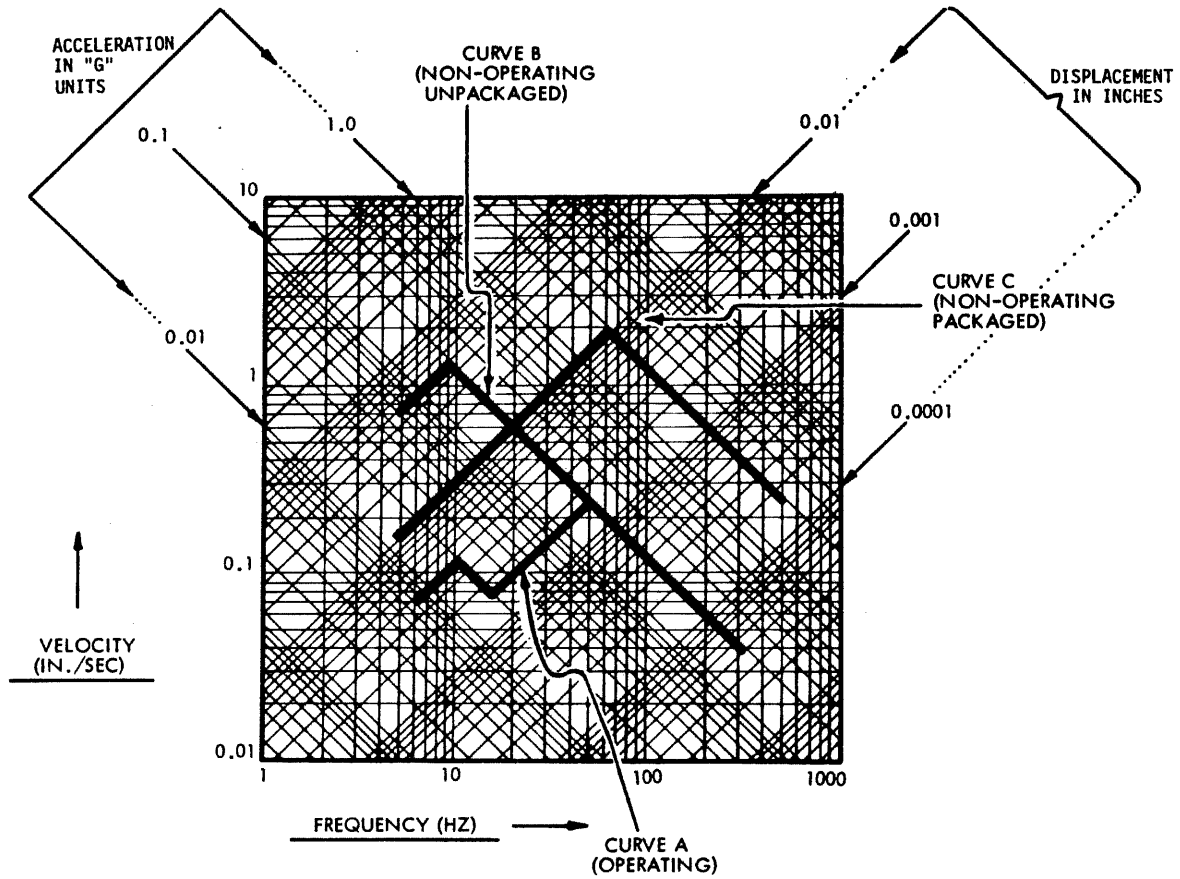

Z097b

Figure 10. Vibration Levels

		PC	SPEC. NO.	SHEET	REV.
		A	77711094	29	A

PRODUCT SPECIFICATION - 9457 Lark Micro Unit

7.4.4 -contd.

2. Transit

Equipment in its normal upright position shall withstand the conditions of vibration and shock injected from the floor in the three major mutually perpendicular axes.

- a. Vibration as shown in Figure 10, Curve C (Non-Operating Packaged).
- b. Shocks of up to 5 g, not exceeding 10 milliseconds in duration. The time between consecutive shocks cannot be less than 5 seconds.

The LMU is packaged for van or air freight shipment and shall withstand drop tests from 30 inches (765 mm) on all surfaces, three edges and one corner, against a concrete floor or equivalent, See Figure 11.

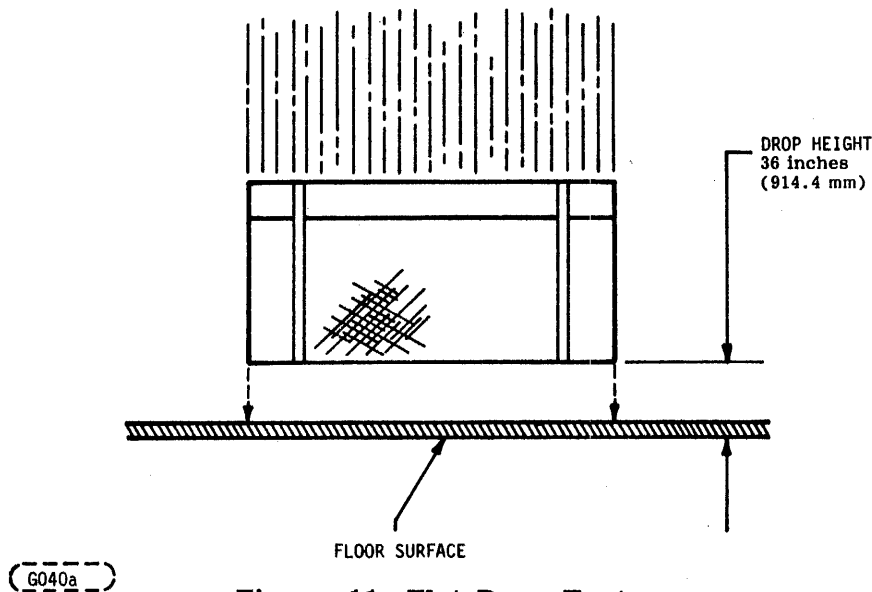

Figure 11. Flat Drop Test

7.4.5 Air Cleanliness

The LMU is designed to operate in an office environment with minimum or no environmental control. Heating is provided, but artificial cooling may not exist for the drive. Natural or forced air ventilation may be used to limit the maximum temperature. This range is considered the minimum acceptable environment for human comfort. In this environment, the LMU will operate with the following levels of contamination:

$$(A \times 10^6 + B \times 10^5 + C \times 10^4) \text{ particles/ft}^3$$

where

A = 5 in the size range of .28 to .42 micron

B = 5 in the size range of .42 to .87 micron

C = 5 in the size range of .87 micron and larger

		PC A	SPEC. NO. 77711094	SHEET 30	REV. A
--	--	---------	-----------------------	-------------	-----------

PRODUCT SPECIFICATION - 9457 Lark Micro Unit

8.0 MEDIA/RECORDING CHARACTERISTICS

8.1 MEDIA CHARACTERISTICS

The media used on the LMU has a diameter of approximately eight inches. Its coating thickness is optimized for high density magnetic recording with densities up to 6774 flux reversals per inch (frpi) and track densities up to 715 tracks per inch (tpi).

A dedicated servo surface is not used with the LMU for head positioning control. Instead, embedded servo information is factory written on each data surface in those areas not occupied by header or data blocks. This pre-recorded servo field is used for carriage positioning, index and sector pulse generation, and PLO reference clock.

8.1.1 Cartridge Description

The LMU cartridge contains a single oxide-coated aluminum disk which is mounted on a self-centering hub and enclosed in a protective plastic case. The cartridge is sealed against dust. When the disk is inserted into the drive, the dust cover opens automatically for spindle and head access and closes automatically when the disk is withdrawn. Optionally a protective case will be available for the cartridge to provide an additional safeguard against contamination or damage resulting from handling or storage.

Cartridge interchangeability between other Model 9457 LMU's using the same format and sector configuration is ensured.

The Model 1208-8 MB cartridge may be used in a READ ONLY operation on Model 9457. The user should expect a increased Read/Seek error rate and limit cartridge accessible cylinders to 205. The cartridge is automatically write protected in this mode.

A write protect tab that is operator changeable prevents inadvertent over-writing of data.

A cartridge is approximately 8.5 inches (215.9 mm) square and 1 inch (25.4 mm) high. Refer to Figure 12.

Cartridge insertion is shown in Figure 13.

8.1.2 Fixed Media Description

The fixed media is a single oxide coated aluminum disk attached to the spindle hub assembly. It is considered part of the basic drive and always remains within the assembly. Protection from damage and dirt is provided by housing it in a special cavity and isolating it from the cartridge receiving mechanism with a protective cover.

		PC	SPEC. NO.	SHEET	REV.
		A	77711094	31	A

PRODUCT SPECIFICATION - 9457 Lark Micro Unit

8.1.2 -contd.

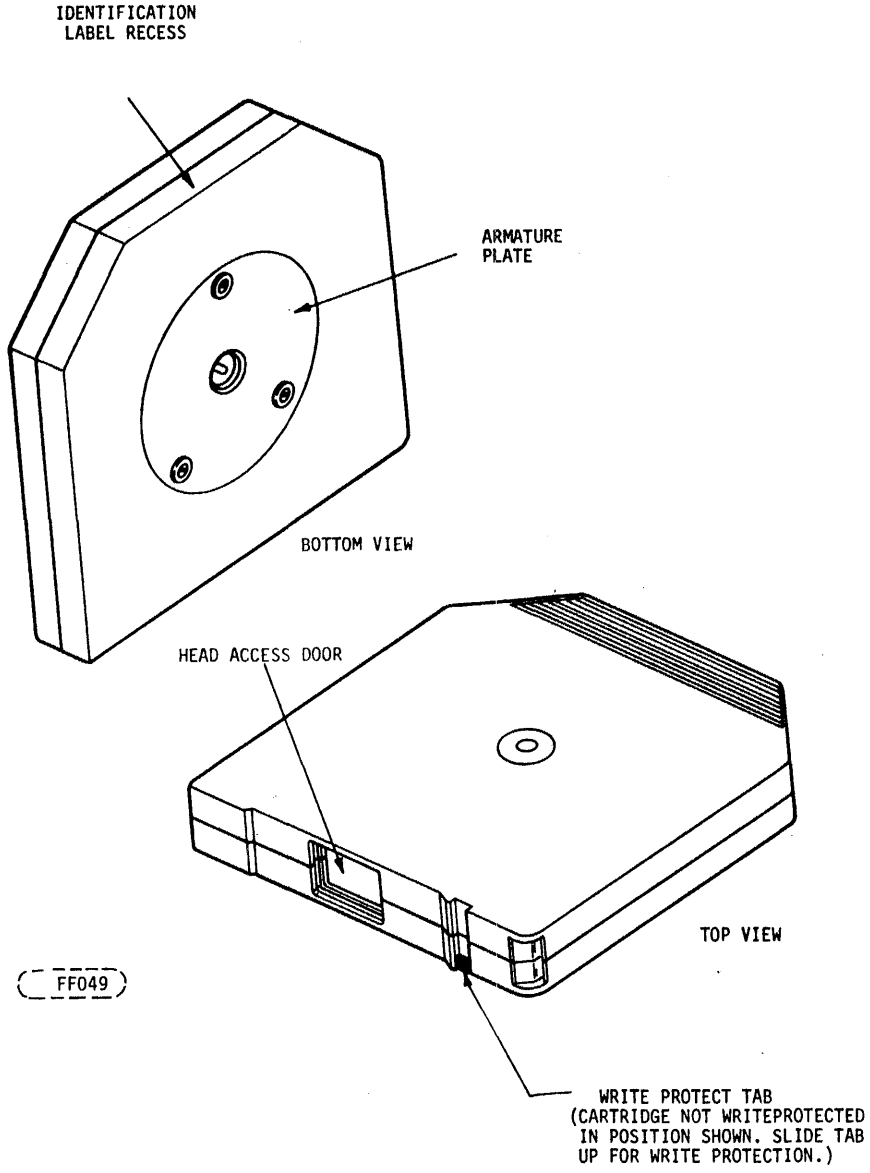

Figure 12. Removable Cartridge

		PC	SPEC. NO.	SHEET	REV.
		A	77711094	32	A

PRODUCT SPECIFICATION - 9457 Lark Micro Unit

8.1.2 -contd.

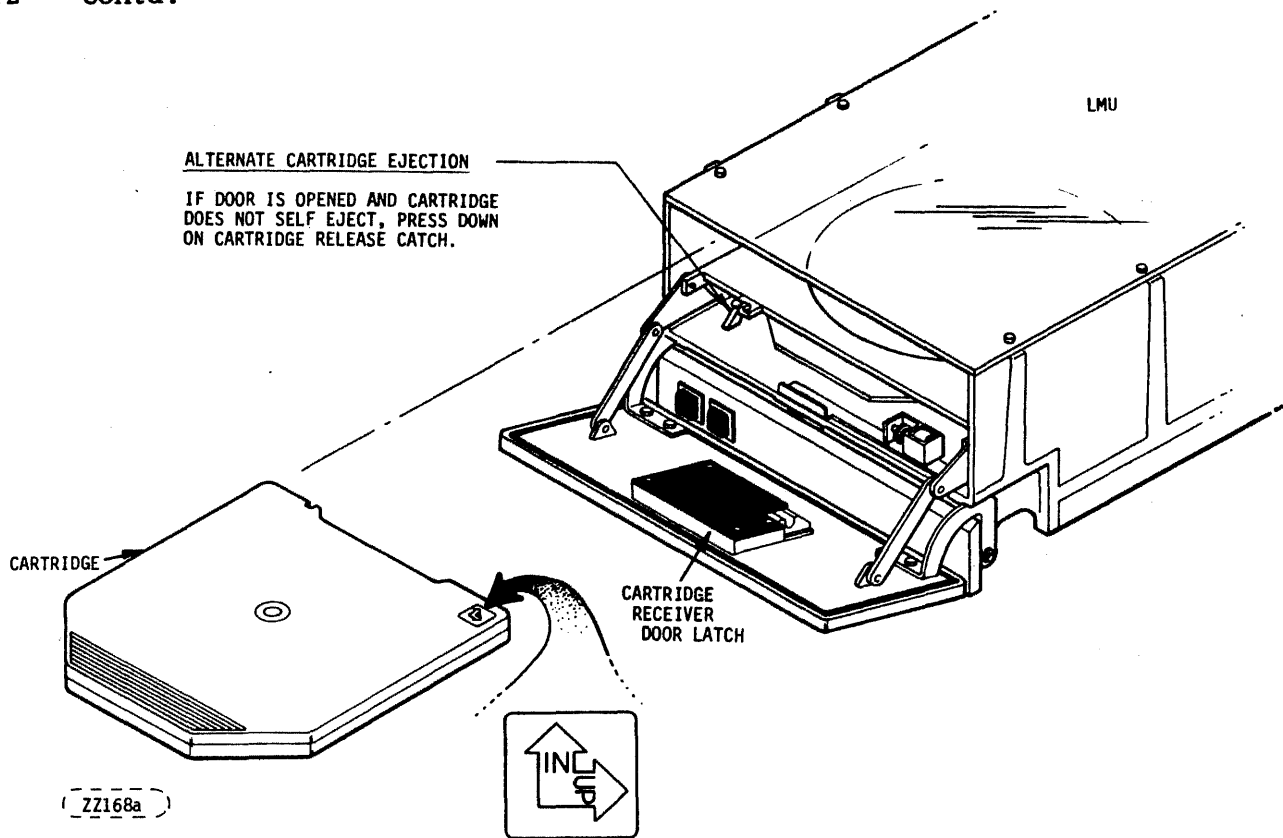

Figure 13. LMU Cartridge Insertion

It is mandatory that fixed media replacement be performed at a depot level maintenance facility or equivalent to ensure the proper environmental control.

8.2 ALLOWABLE MEDIA DEFECTS

Media defects are characterized as being either correctable or uncorrectable as a function of the type and magnitude of the media flaw. Various error correction codes may be implemented to correct errors in the data read from the disk. However, the code chosen should be consistent with the media manufacturer's testing and certification methods. In the LMU, media certification is performed using the following standards:

1. An error burst of 11 bits or less is a correctable error.
2. An uncorrectable error is one greater than 11 bits in length.
3. Only one correctable error may occur in each sector or that sector must be classified as uncorrectable.

		PC	SPEC. NO.	SHEET	REV.
		A	77711094	33	A

PRODUCT SPECIFICATION - 9457 Lark Micro Unit

8.2 -contd.

At the time of manufacture, media defect information is recorded on track 623, surface 0, sector 0 of each disk. This identifies flagged track/sector data for those users who wish to use it as a part of a system initialization and track or sector deallocation routine without recertification. If the user wishes to use this information, it is imperative not to write on this area of the disk until such time that it can be recovered.

Figure 14 shows the recording format for surface 0, track 623, and sector 0.

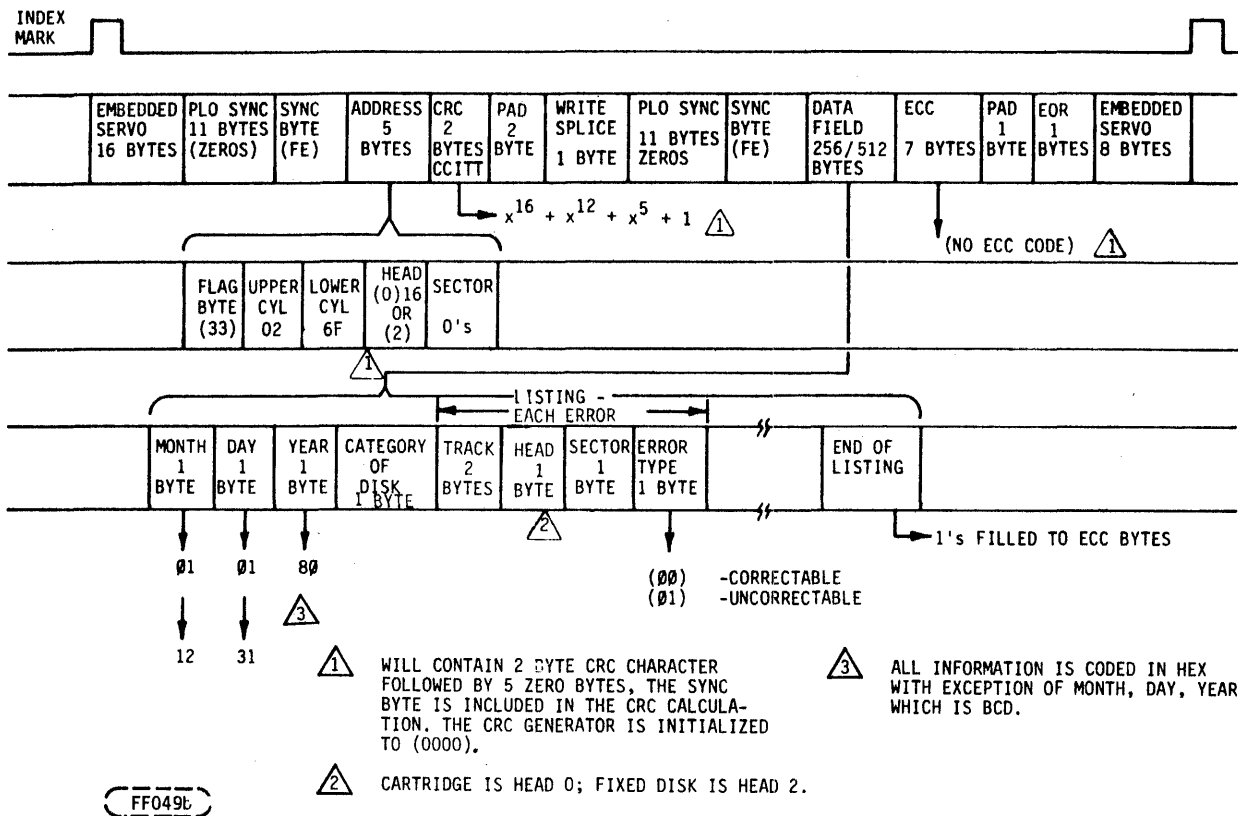

**Figure 14. Format for Surface 0, Track 623, Sector 0-
Factory Flagged Track Data**

		PC	SPEC. NO.	SHEET	REV.
		A	77711094	34	A

PRODUCT SPECIFICATION - 9457 Lark Micro Unit

8.2.1 LMU Fixed Media

The LMU fixed media will:

1. Have no media defects on cylinder 0 and 623.
2. Have no more than 12 correctable error tracks per surface.
3. Have no more than 4 uncorrectable error tracks per surface.
4. A track could have up to 3 defective sectors.
5. Maximum total number of defective sectors for both surfaces shall not exceed 50.

This permits those users who have implemented error correction codes (ECC) into their systems the use of the 12 correctable tracks.

For those users who choose not to use ECC, it is recommended that no more than 608 tracks be used for data storage and retrieval, leaving the remainder of error free tracks as spares that may be used for alternate track assignments.

Better utilization of disk capacity is realized when using sector de-allocation as opposed to track de-allocation.

8.2.2 LMU Cartridge Media

The magnetic recording surface of the LMU cartridge is the same as that of the fixed media. Media certification is performed using the same criteria. Refer to Disk Cartridge Product Specification, 64717100, for further details.

8.3 RECORDING CHARACTERISTICS

The recording system used in the LMU employs 2,9 recording code. This code yields a bits-per-inch to flux-reversals-per-inch ratio of 1.5 to 1. Data recorded on a track using this code at 6774 flux reversals per inch is effectively recording data on that track at 10,161 bits per inch.

Briefly, this code operates in the following manner:

1. The NRZ serial data which is to be written on the disk is examined in a bit-field form.
2. Within the 9-bit field each 3-bit sequence is encoded into a recorded zone containing not more than two flux reversals.
3. The presence or absence of a flux reversal and their placement within the zone is a function of the specific three bits of data to be written in the zone and the contents of the two zones which are immediately adjacent to the zone being written.

		PC	SPEC. NO.	SHEET	REV.
		A	77711094	35	A

PRODUCT SPECIFICATION - 9457 Lark Micro Unit

8.4 DATA SECURITY

Under normal adapter input/output operation, it is not possible to write a pattern other than that on the Write Data lines. The bit pattern can only be alternated when the LMU signifies an On Cylinder status, is not write protected via hardware or operator control, and Write Gate is active, but only upon specific selection of the LMU. Data is protected by inhibiting Write Gate in the following fault conditions:

1. Write Gate and Servo Write Inhibit

This detects the condition of a missed embedded servo field which causes a write protect condition for the following data field, AND'ed with an attempt to write.

2. Write Gate and Microcomputer Write Protect

This detects an attempt to write when write protected by the microcomputer. The microcomputer may write protect when off cylinder during seek, during command dialogue, if a fault condition exists, if Fixed or Cartridge Write Protect is active and the associated volume is selected, or when not ready.

3. Read Gate and Off Cylinder

This detects an attempt to read while off cylinder.

4. Read Gate and Write Gate

This is a simultaneous occurrence of both Write Gate and Read Gate.

Under any of the following conditions, a Write Inhibit and an emergency retract of the heads is performed so that data is protected:

1. Loss of AC line power

2. Loss of spindle speed

3. Pre-amp faults

- a. Write Gate and no Write Data
- b. Head shorted or open
- c. Read active and DC write current

4. Servo Faults

- a. +5, -5.2, +16.5, -16.5 V dc failure
- b. Retract capacitor charge low
- c. Microcomputer detected fault

Protective features are incorporated within the LMU to prevent altering data due to abnormalities during start-up or shutdown.

		PC	SPEC. NO.	SHEET	REV.
		A	77711094	36	A

PRODUCT SPECIFICATION - 9457 Lark Micro Unit

9.0 ERROR RECOVERY CONSIDERATIONS

9.1 EARLY/LATE DATA STROBE AND CARRIAGE OFFSET

Consistent with media recording employing flux reversals up to 6774 flux reversals per inch and 715 TPI, the LMU incorporates provisions to strobe the data window early or late to compensate for peak shifting due to bit crowding. This capability is controlled via an adapter command and would normally be used when a read error occurs during reading as part of program controlled error recovery routine. To supplement this capability the 9457 LMU incorporates plus and minus carriage offsets to assist in data recovery.

9.2 ECC IMPLEMENTATION

It is recommended that the host system implement ECC (error correction codes) error correction techniques with the LMU. The code chosen should be consistent with the criteria in Section 8.2.

A factor to consider is the 2,9 recording method used. In MFM recording, error bursts are directly proportional to the number of affected flux reversal positions; therefore, no error propagation occurs with media defects. In other words, "N" bad flux reversals on the recording surface equals "N" defective bits in the decoded data.

With the 2,9 recording method, incoming binary data passes through complex encoding circuitry and is written on the media in a coded manner (that is, three binary bits equal six possible flux reversal sites on the recorded media). Resultantly, a media defect in a current flux reversal sequence may propagate into adjacent flux reversal groups resulting in a decoded data error burst of greater length than the actual media defect.

10.0 OPTIONAL FEATURES

The following options are available for the Model 9457 Lark Micro Unit. The desired options should be requested on the initial Model 9457 order to insure "as shipped" configuration includes all necessary items for operation.

10.1 POWER SUPPLY

GENERAL

The Power Supply provides all the DC and AC voltages necessary for the operation of one Lark Micro Unit. It incorporates a Ferro-Resonant transformer and DC regulation/filtering to satisfy Lark Micro Unit requirements. It contains an AC line filter to comply with electromagnetic compatability standards and a

		PC	SPEC. NO.	SHEET	REV.
		A	77711094	37	A

PRODUCT SPECIFICATION - 9457 Lark Micro Unit

10.1 -contd.

combination On/Off switch/circuit breaker on the AC input power source. Provisions are provided within the package for an interface adapter PWA allowing adaptation of Lark Device Interface (LDI) to other applications. Reference Figures 15 and 16.

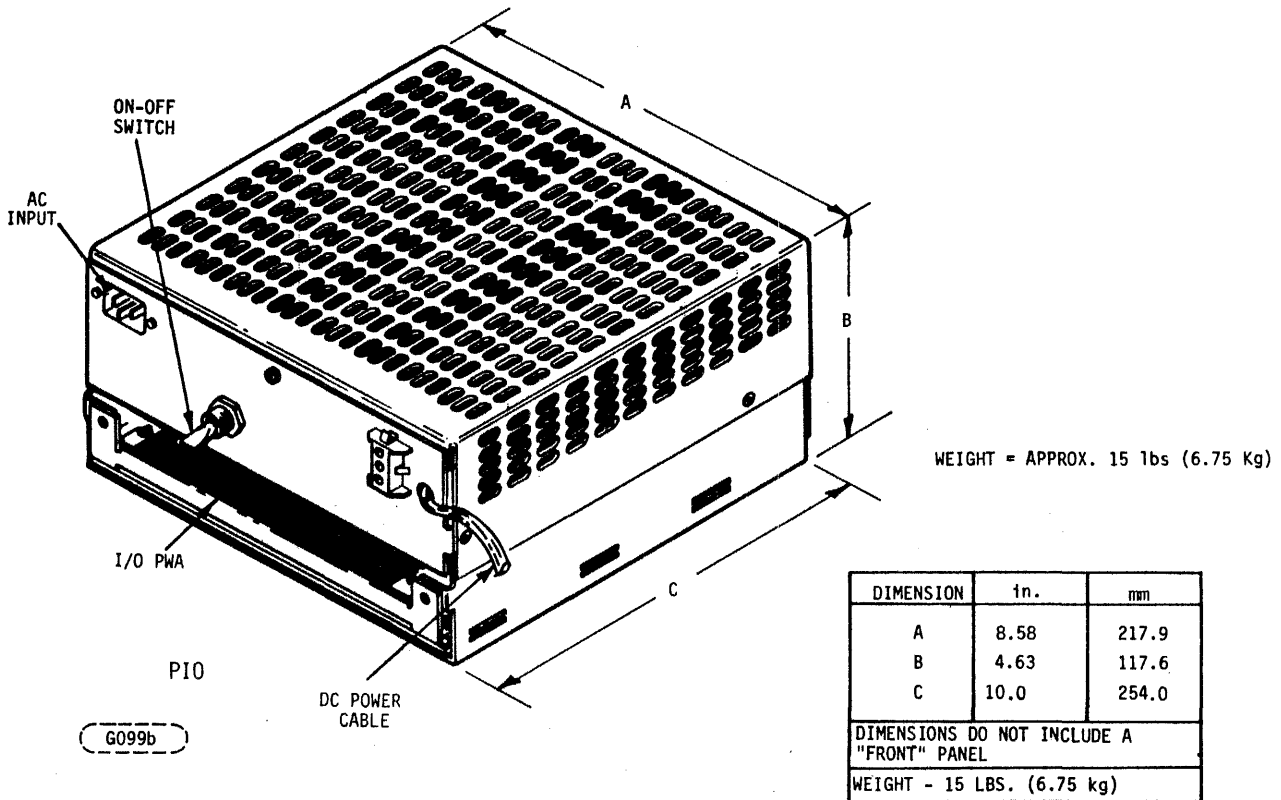

Figure 15. Power Supply

		PC	SPEC. NO.	SHEET	REV.
		A	77711094	38	A

PRODUCT SPECIFICATION - 9457 Lark Micro Unit

10.1 -contd.

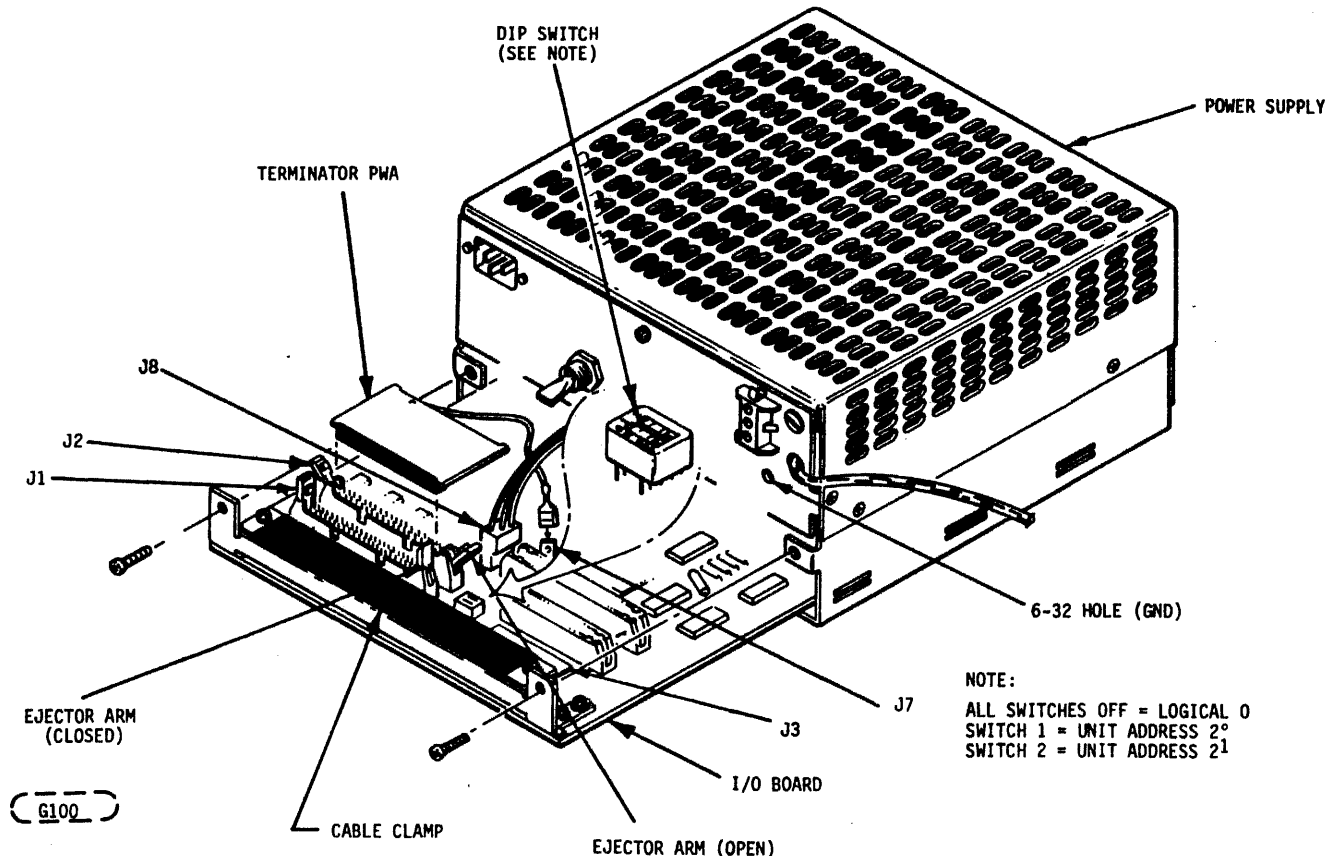

Figure 16. Power Supply with Optional SMD Adapter I/O Board

The Power Supply is available in two basic versions, a 60 Hertz model and a 50 Hertz model.

CUSTOMER ORDER NO.	CDC PART NUMBER	FREQUENCY
TBD	77611431	60 Hz
TBD	77611432	50 Hz

Documentation

The following documentation is available for field support of the Lark Power Supply.

- Hardware Installation/Operation Manual 77711033
- Hardware Maintenance Manual 77711038

		PC	SPEC. NO.	SHEET	REV.
		A	77711094	39	A

PRODUCT SPECIFICATION - 9457 Lark Micro Unit

10.1 -contd.

Electrical Characteristics

The AC power requirements for each power supply is listed in Table 5.

Table 5. Primary Voltage Requirements

VOLTAGE (VAC)	TOLERANCE (VAC)	FREQUENCY (Hz)	TOLERANCE (Hz)
120	-16, +8	60	+0.6, -1.0
220-240	-29, +16	50	+0.5, -1.0

The DC power output is capable of meeting all requirements of Tables 2 and 3 over the full environmental range as defined for the Lark Micro Unit.

The following Table 6 identifies the DC output characteristics.

Table 6. Power Supply DC Outputs

	OUTPUT	
	+5 V/-5.2 V	±16.5 V
AVAILABLE CURRENT **	2.8/3.5 A	1.3 (AVG)
REGULATION (AT CONNECTOR)	+2%/-3%	±10%
RIPPLE VOLTAGE (P-P)	50 mV	500 mV
OUTPUT FUSES (Slow Blow)	(50 Hz ONLY 5A*)	2.5 A MDA*
OVER VOLTAGE PROTECTION	6 +/- 6.8 V	NONE

*SUBJECT TO CHANGE

The Lark Power Supply shall meet the minimum DC output voltages under the conditions of input voltage interruption listed in Table 7.

Table 7. Input Voltage Interruption

CONDITION	INPUT VOLTAGE	DURATION	FREQUENCY OF OCCURRENCE (FOR TEST PURPOSES)
A	50% of Nominal	1/2 Cycle	Once in 10 seconds
B	80% of Nominal	30 Cycles	Once in 60 seconds

NOTE 1. CONDITION A AND B WILL NOT OCCUR SIMULTANEOUSLY.

NOTE 2. THE TRANSIENT ENERGY LOSS APPLIES TO BOTH THE 60 Hz AND 50 Hz UNITS.

** POWER RESERVE AVAILABLE FOR CUSTOMER DESIGNED INTERFACE ADAPTER IS:
 1.0 A MAX +5.0 V ±5%
 .250 A MAX -5.2 V ±5%

		PC	SPEC. NO.	SHEET	REV.
		A	77711094	40	A

PRODUCT SPECIFICATION - 9457 Lark Micro Unit

10.1 -contd.

The grounding of the Power Supply is accomplished at the mounting interface of the Power Supply through the attaching hardware. If desired, an external ground point is provided on the chassis of the Power Supply. Reference Figure 17.

Environmental

The Lark Power Supply will meet all environmental requirements of the Lark Micro Unit as specified in earlier sections of this specification. The unit is convection cooled when mounted in either the vertical or horizontal plane and must be properly ventilated so that cooling air entering the power supply does not allow temperatures as measured 1/2 inch away from convecting surfaces to exceed 120° F (49° C).

Reliability and MTBF

The Lark Power Supply shall have no limitation on useful service life. MTBF is expected to exceed 60,000 hours.

		PC	SPEC. NO.	SHEET	REV.
		A	77711094	41	A

PRODUCT SPECIFICATION - 9457 Lark Micro Unit

10.1 -contd.

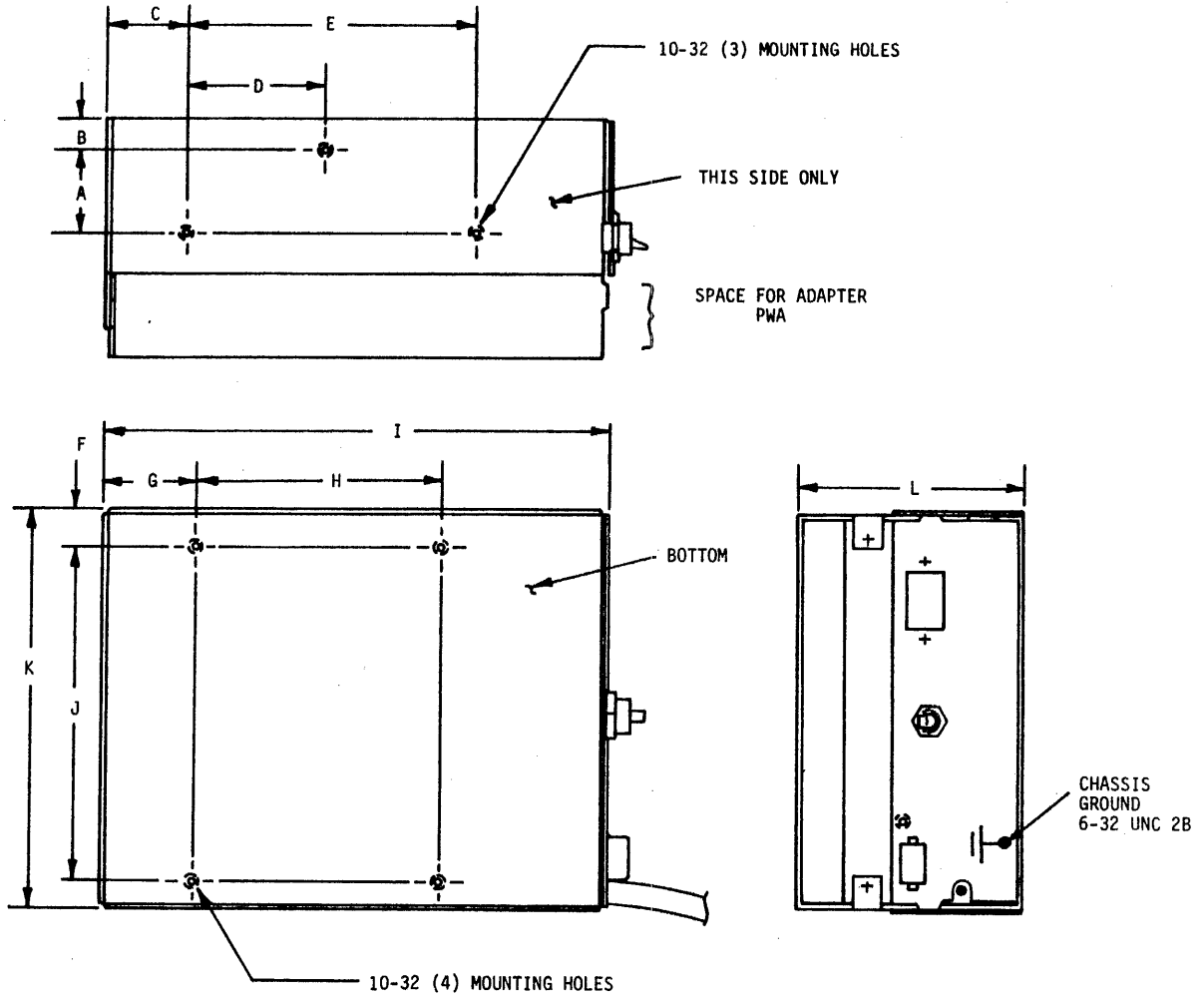

NOTE

PENETRATION OF MOUNTING HARDWARE NOT TO EXCEED 0.25 in (6.35 mm). DIMENSIONS DO NOT INCLUDE USER FURNISHED FRONT PANEL

DIMENSION	INCHES	mm
A	1.50	38.1
B	0.69	17.5
C	1.75	44.5
D	2.50	63.5
E	5.75	146.1
F	0.54	13.7
G	1.81	46.0
H	4.88	123.8
I	10.0	254.0
J	7.50	190.5
K	8.57	217.7
L	4.63	117.6

ZZ169a

Figure 17. PIO Mounting Hole Data

		PC	SPEC. NO.	SHEET	REV.
		A	77711094	42	A

PRODUCT SPECIFICATION - 9457 Lark Micro Unit

10.1 -contd.

Mounting and Dimensions

Figure 17 identifies the location of mounting holes and dimensional data, the power supply is designed to mount in either the horizontal or vertical plane. Maximum screw penetration into the power supply enclosure is 0.25 inches. The enclosure can accommodate an auxiliary interface adapter PWA 8.2 inches square located beneath the power section of the supply.

Electrical Interface

AC power cable (input) and the AC and DC power cables (output) are furnished with each power supply. The specifications of these cables are covered in the following: Figures 18, 19, 20, and 21.

CDC NO.	REF. FIG.	"L"	"D"	AWG	INSUL. TYPE	RATINGS
75778702	19	7.50 ft. 2.30 m	0.253 in 6.430 mm	18/3	SVT	10 A, 125 V ac
75778711	20	7.50 ft. 2.30 m	0.253 in 6.430 mm	18/3	SVT	6 A, 250 V ac

Figure 18. AC Power Cable (Input)

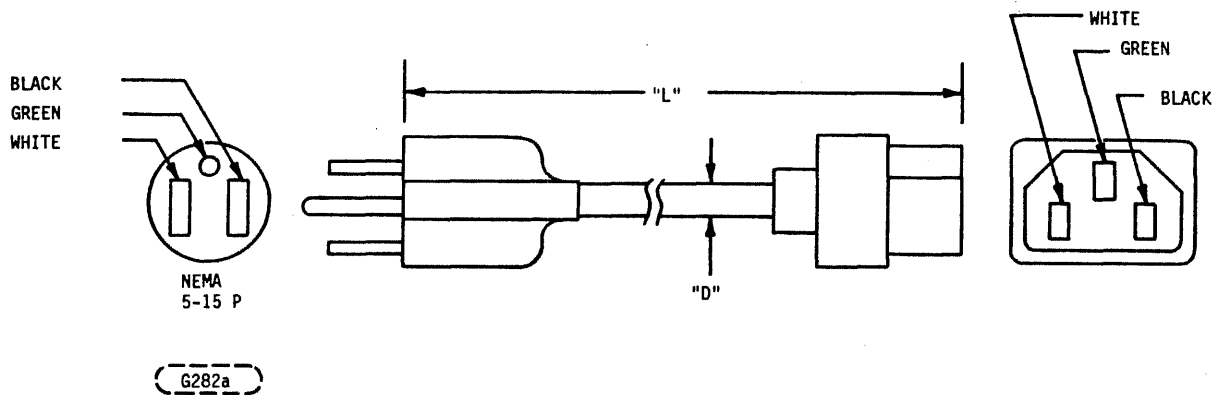

Figure 19. AC Power Cable (60 Hz)

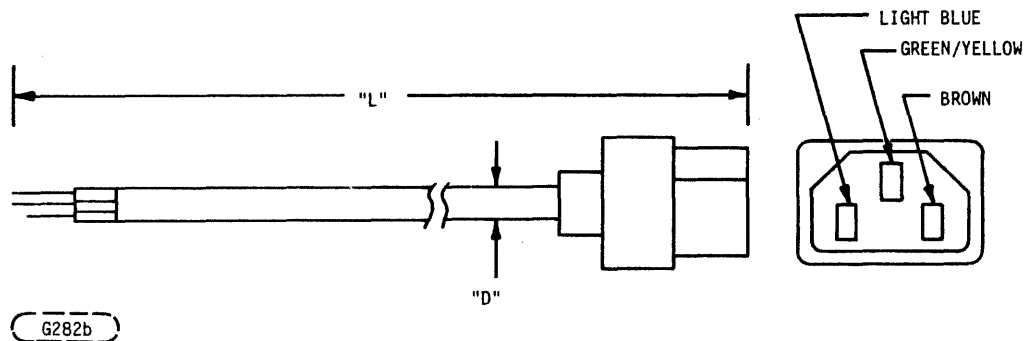

Figure 20. AC Power Cable (50 Hz)

		PC	SPEC. NO.	SHEET	REV.
		A	77711094	43	A

PRODUCT SPECIFICATION - 9457 Lark Micro

10.1 -contd.

<u>DESCRIPTION</u>	<u>CDC P/N</u>	<u>NEMA Configuration</u>
120 V, 15 A, 60 Hz, 2-pole 3-wire receptacle connector at PIO end, 2-pole, 3-wire plug connector at power source end (see Figures 19 and 20.)	75778702	5-15 P

The mating receptacle connector required at the AC power source is NEMA Configuration: 5-15R

A color-coded power cable is supplied with the 50 Hz drive, but the 50 Hz power source end connector must be furnished by the user. The cable color code and unit power requirements are as follows:

<u>DESCRIPTION</u>	<u>COLOR-CODE</u>	
220-240 V 50 Hz	Brown	- Phase One
	Blue	- Neutral
	Green and Yellow	- AC Equipment Ground Wire
		#18 AWG

REF FIG	"L"	"D"	AWG	CABLE TYPE	INSUL TYPE	SHIELD
21	4.00 ft 1.23 m	0.424 in 10.77 mm	18/7	94259100	PVC GRAY	YES 

 SHIELD OF OUTPUT CABLE IS CONNECTED TO POWER SUPPLY CHASSIS: CONNECTOR END IS CONNECTED TO MATING TAB ON DRIVE.

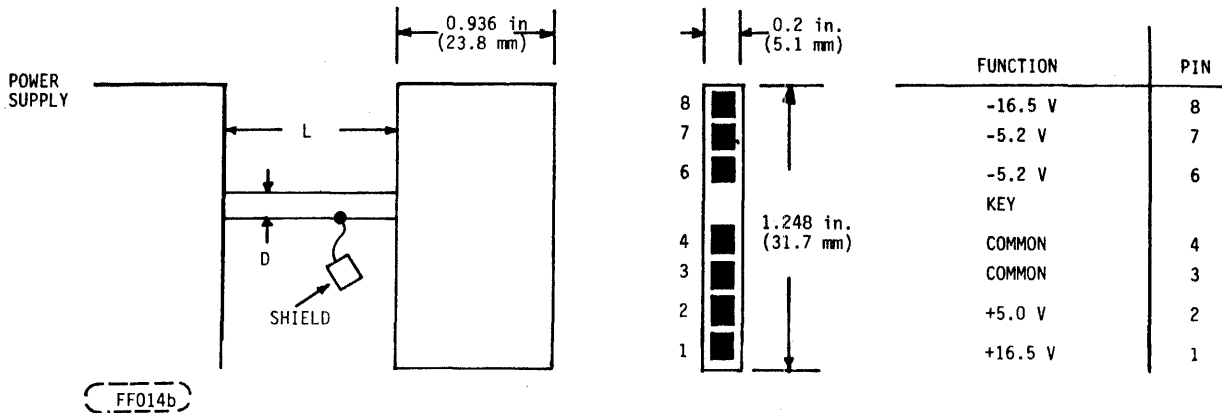

Figure 21a. DC Power Cable

PART NUMBER	LENGTH			
	CM	INCHES		
TAB XX	$\frac{121.9}{48}$	$\frac{45.7}{18}$	$\frac{61.0}{24}$	$\frac{91.4}{36}$
776228XX	45	46	47	47

 FF014c

Figure 21b. AC Power Cable (Output)

		PC	SPEC. NO.	SHEET	REV.
		A	77711094	44	A

PRODUCT SPECIFICATION - 9457 Lark Micro Unit

10.1 -contd.

The part numbers for AC and DC power connectors at drive end of cable are provided below.

AC POWER CONNECTOR

3 Circuit Position
Mat 'N' Lock Type Male
Housing with Female
Contacts

<u>CDC PN</u>	<u>AMP PN</u>
83435302-1	1-480700-0

CONTACT
(3 Req.)

<u>CDC PN</u>	<u>AMP PN</u>
83435507-5	350536-1
	or
	350550-1

DC POWER CONNECTOR

8 Circuit Position Female
Connector with High Pressure
Contacts

<u>CDC PN</u>	<u>AMP PN</u>
10128944	641570-8

Keying Plug in #5 Circuit Position
for above

<u>CDC PN</u>	<u>AMP PN</u>
10128937-9	640431-8

10.2 INTERFACE ADAPTER

General

The SMD Interface Adapter Board is available to convert the Lark Device Interface (LDI) to standard Storage Module Interface (SMD). The adapter is a PWA contained within the power supply. (Reference Figure 22b.) Interconnecting cables interface the Lark Micro Unit to the adapter and the controller interfaces to the adapter with standard "A" and "B" cables. The combination of Lark Micro Unit plus power supply and SMD Adapter is referred to as the Lark Module Drive (LMD).

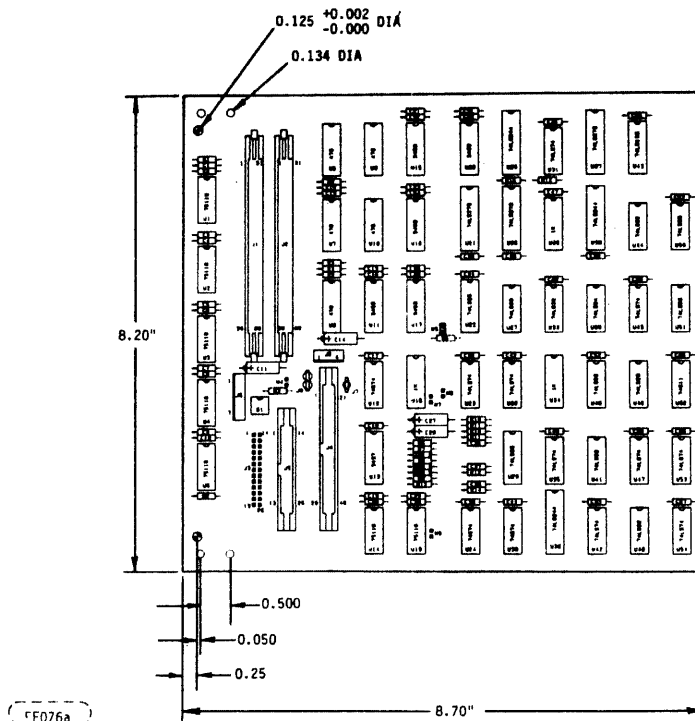
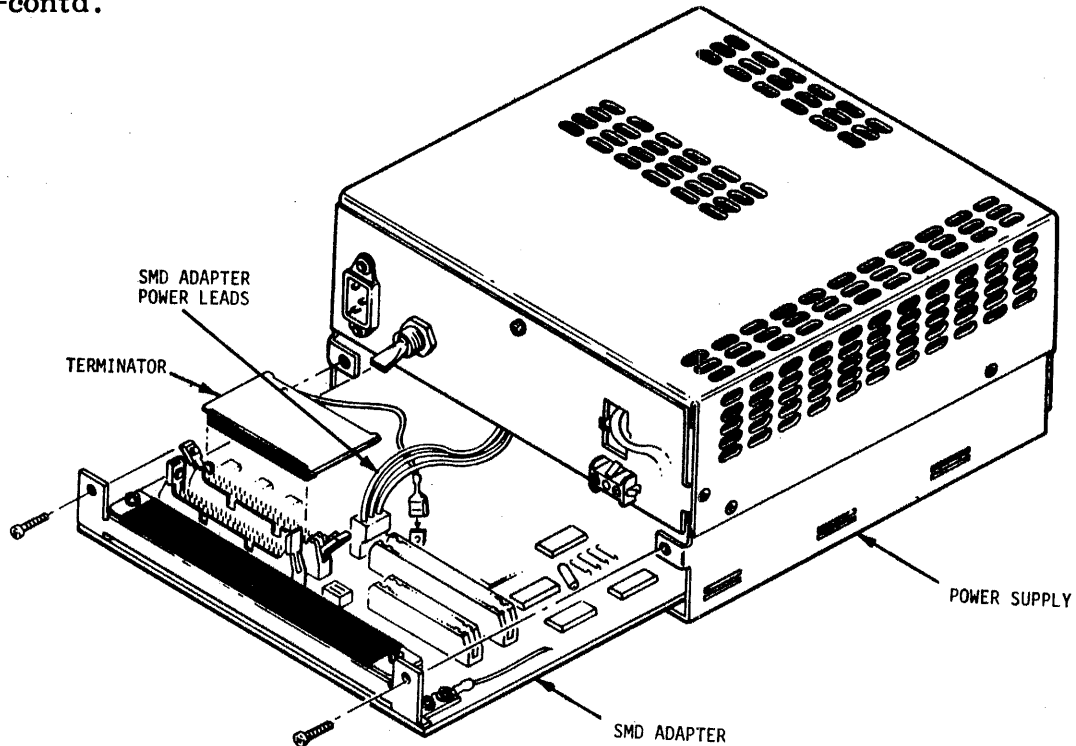

Figure 22a. SMD Adapter Dimensions

		PC	SPEC. NO.	SHEET	REV.
		A	77711094	45	A

PRODUCT SPECIFICATION - 9457 Lark Micro Unit

10.2 -contd.



G144a

Figure 22b. Power Supply and SMD Adapter

The SMD Adapter incorporates several pluggable jumper options to allow interfacing with existing SMD/CMD controllers that may have unique requirements. The adapter is, however, initially shipped in a standard configuration and unique requirements are incorporated during the evaluation phase of the Lark Module Drive. The standard SMD Adapter number is listed below.

<u>CDC PART NUMBER</u>	<u>ADAPTER TYPE</u>
77683700	LDI to SMD

Provisions are incorporated to allow star or daisy chain system connections. A pluggable termination is supplied with each SMD Adapter Board.

		PC	SPEC. NO.	SHEET	REV.
		A	77711094	46	A

PRODUCT SPECIFICATION - 9457 Lark Micro Unit

10.2 -contd.

Documentation

The following documentation is available for field support of the SMD Adapter.

- Hardware Installation/Operation Manual 77711033
- Hardware Maintenance Manual 77711038
- Flat Cable Interface Specification 64712400

Electrical Requirements

The SMD Adapter requires DC power that is normally supplied via power leads integrated within power supply. See power requirements listed below for user supplied power applications.

ADAPTER TYPE	VDC	POWER	
		CURRENT	REG.
LDI to SMD	+5.0	1.0 A	±2%
	-5.2	0.3 A	±2%

Environmental

The Lark SMD Adapter will meet all environmental requirements of the Lark Micro Unit as defined in earlier sections of this specification.

Reliability and MTBF

The Lark SMD Adapter shall have a useful service life consistent with LMU as specified in Section 6.2.3. MTBF is expected to exceed 60,000 hours.

Interface and Cabling

For LMD applications, cabling consists of interconnecting the Lark Micro Unit to power supply and SMD Adapter PWA. This involves DC and AC Power cables from the power supply and a 40 and 26 pin flat cable from SMD adapter for command and data signals respectively. System connections via standard "A" and "B" cables to SMD adapter complete the cabling. Reference Figures 23 and 24.

		PC	SPEC. NO.	SHEET	REV.
		A	77711094	47	A

PRODUCT SPECIFICATION - 9457 Lark Micro Unit

10.2 -contd.

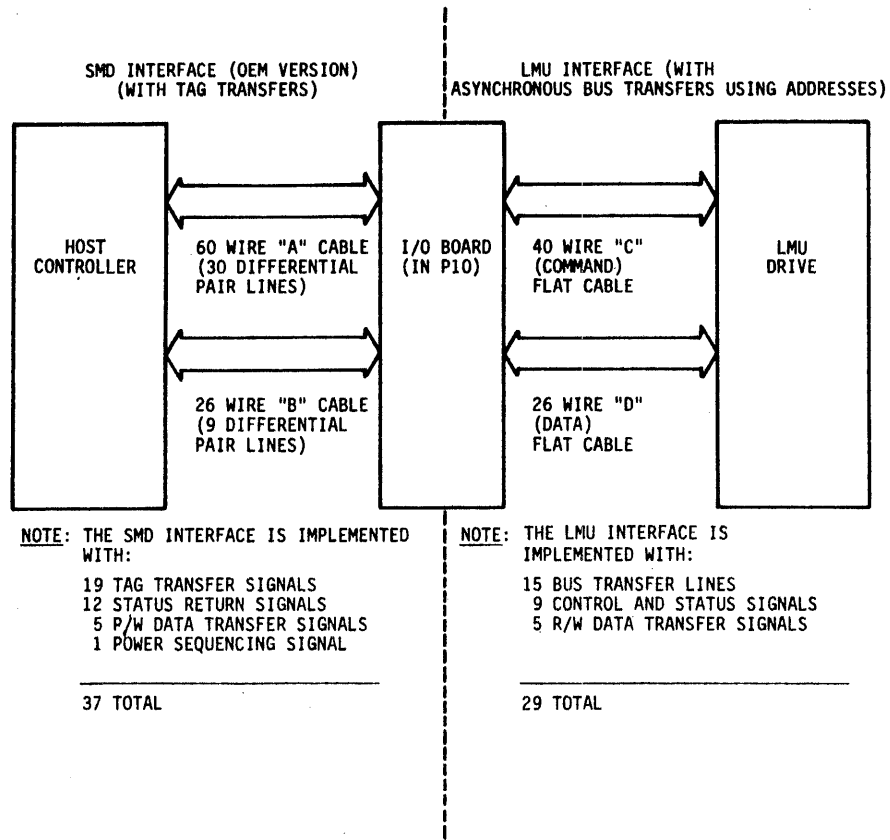

6147b

Figure 23. Host Controller to LMU Interface Diagram

		PC	SPEC. NO.	SHEET	REV.
		A	77711094	48	A

PRODUCT SPECIFICATION - 9457 Lark Micro Unit

10.2 -contd.

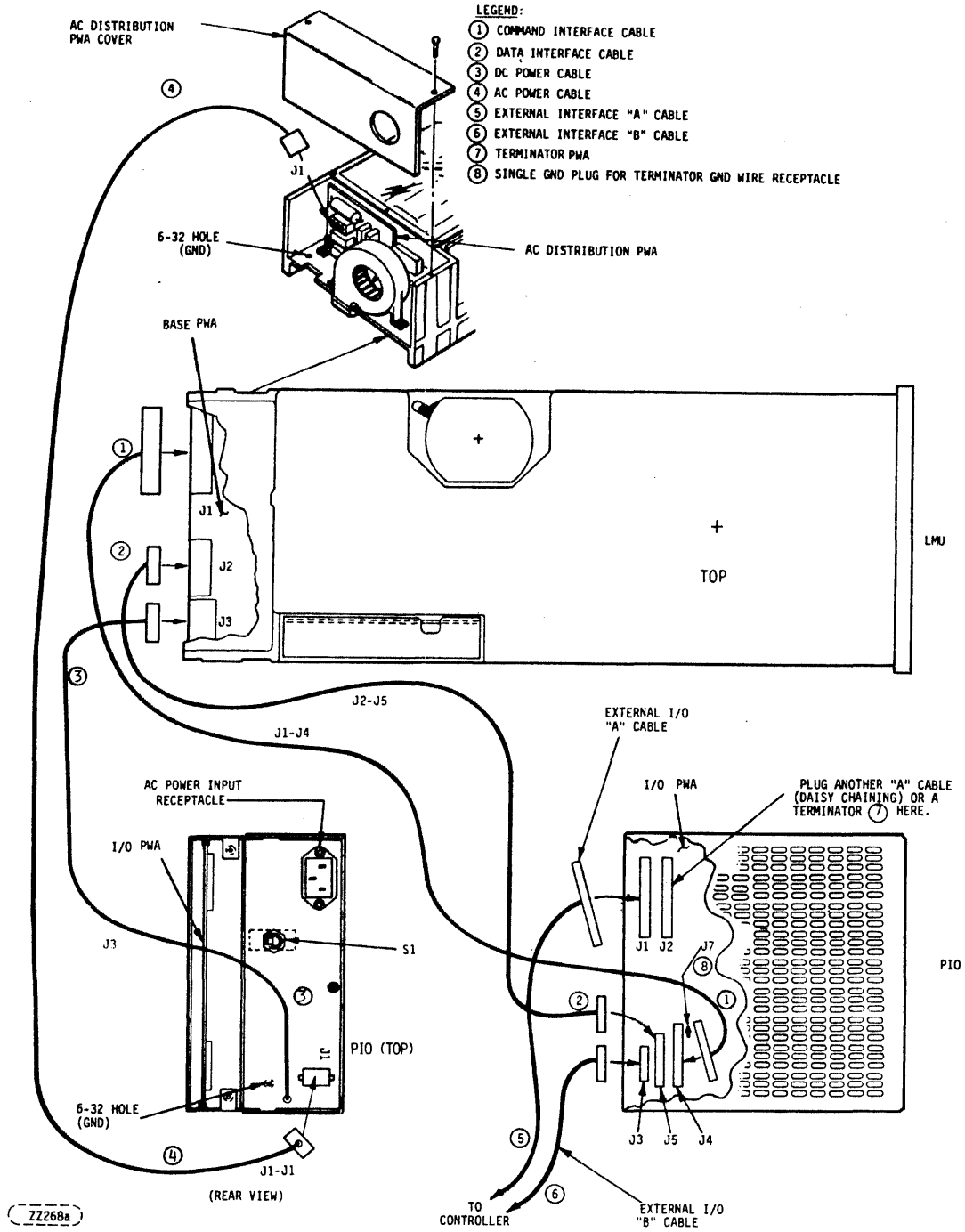

Figure 24. LMD Cable Connections

		PC	SPEC. NO.	SHEET	REV.
		A	77711094	49	A

PRODUCT SPECIFICATION - 9457 Lark Micro Unit

10.2 -contd.

Interconnecting Cables and Connectors

The 40 pin and 26 pin flat command and data cables interconnecting the Lark Micro Unit to SMD Adapter are supplied with a standard 4 foot length. Optional lengths available upon request are 18 inches, 24 inches, and 36 inches. If applications require cable lengths in excess of the standard 4 foot length, shielded cables may be used for a maximum length of 10 feet. Reference Table 8 when ordering these cables.

Table 8. Interconnecting Cables (C & D)

		LENGTH $\frac{\text{CM}}{\text{INCHES}}$			
PART NUMBER		121.9 48	45.7 18	61.0 24	91.4 36
TAB XX	COMMAND CABLE 'C' 776228XX	00	01	01	03
	DATA CABLE 'D' 776228XX	20	21	22	23

For those users who wish to fabricate their own cables, the necessary information is provided in Tables 9 and 10.

		PC	SPEC. NO.	SHEET	REV.
		A	77711094	50	A

PRODUCT SPECIFICATION - 9457 Lark Micro Unit

10.2 -contd.

Table 9. Interconnecting Cable Characteristics

<u>Command Cable Characteristics</u>	
Type:	40 wire flat cable (not twisted)
Wire size:	28 AWG, 7 strand
Voltage:	300 V (maximum)
Length:	4 feet (maximum) (including all daisy chain)
Impedance:	100 Ohms
Wire spacing:	0.050 inch
<hr/>	
<u>Data Cable Characteristics</u>	
Type:	26 wire flat cable with ground plane and drain wire
Wire size:	28 AWG, 7 strand
Voltage:	300 V (maximum)
Length:	4 feet (maximum)
Impedance:	65 Ohms
Wire spacing:	0.050 inch
<hr/>	
<u>Shielded Command and Data Cable Characteristics</u>	
Type:	40/26 wire flat cables with shield and jacket
Wire size:	28 AWG, 7 strand
Voltage:	300 V (maximum)
Length:	10 feet (maximum)
Impedance:	50 to 80 Ohms
Wire spacing:	0.050 inch

		PC	SPEC. NO.	SHEET	REV.
		A	77711094	51	A

PRODUCT SPECIFICATION - 9457 Lark Micro Unit

10.2 -contd.

Table 10. Interconnecting Cable and Connector Part Numbers

<u>ITEM NO.</u>	<u>DESCRIPTION</u>	<u>CDC PART NUMBER</u>	<u>VENDOR/ PART NUMBER</u>
1	Connector (40 conductor)	92014152-0/54-6	Berg 65948-440/640
2	Connector (40 conductor daisy chain)	92014153-8/55-3	Berg 65948-540/740
3	Connector (26 conductor)	92014136-3/38-9	Berg 65948-426/626
4	Right angle header (40 conductor)	51847515	Berg 65496-025
5	Right angle header (26 conductor)	51847513	Berg 65496-013
6	Vertical header (40 conductor)	95433303	AMP 102154-9
7	Vertical header (26 conductor)	95433301	AMP 102154-6
8	Cable (40 conductor)	65832230	3M 3365-40
9	Cable (26 conductor)	75884912-9	3M 3476-26
10	Shielded cable (40 conductor)	NA	151-2830-040 Spectra-Strip
11	Shielded cable (26 conductor)	NA	151-2830-026 Spectra-Strip

Items 1 and 3 are closed-end cover connectors to be used at the end of cables to prevent the cable from shorting with drive board runs. Item 2 is an open-end cover connector which can be used for daisy chaining. Items 8 through 11 are part numbers for the cables described in this section.

		PC	SPEC. NO.	SHEET	REV.
		A	77711094	52	A

PRODUCT SPECIFICATION - 9457 Lark Micro Unit

10.2 -contd.

System I/O Cables (A & B)

The following information is supplied regarding controller to SMD Adapter cabling. These are the standard SMD Interface cables consisting of a 60 pin and a 26 pin flat cable.

SMD I/O CABLE AND TERMINATOR PART NUMBERS

<u>CABLE</u>	<u>QUANTITY</u>	<u>PART NO.</u>
"A" Cable (Controller to PIO) (Same connector on each end.)	One per PIO in radial, one per multispindle installation in daisy chain.	△ 775642XX
"A" Cable (Device to PIO) (Same connector on each end.)	One less than total devices in the daisy chain.	△ 775642XX
"B" Cable (Controller to PIO)	One per PIO	△ 775643XX
Terminator	One per PIO in radial, one per multispindle installation in Daisy chain (one is provided with each I/O PWA).	75886100

△ Last two digits denote length. (For cable length, see below).

SMD I/O CABLE LENGTH AND TABS

Part No.	Cable Length in Meters									
	1.52	1.83	2.44	3.05	4.58	6.96	7.63	9.15	12.2	15.24
	5	6	8	10	15	20	25	30	40	50
TAB (XX) "A" Cable 775642XX	00	01	02	03	04	05	06	07	08	09
"B" Cable 775643XX	00	01	02	03	04	05	06	07	08	09

		PC	SPEC. NO.	SHEET	REV.
		A	77711094	53	A

PRODUCT SPECIFICATION - 9457 Lark Micro Unit

10.2 -contd.

SMD I/O CABLE CHARACTERISTICS AND CONNECTOR PART NUMBERS

"A" CABLE

ITEM*	DESCRIPTION	CDC P/N	BERG P/N	SPECTRA-STRIP P/N
1	Connector (60 pos)	94361115	65043-007	
3	Contact, Insert	94245603	48048	-----
2	Flat Cable (twisted-pair), 30 pair, 28 AWG	95043902		3CT-6028-7B-05-100

"A" Cable Mating Receptacle on Unit or Controller.

ITEM*	DESCRIPTION	CDC P/N	3M P/N
4	60 pin, vertical header	91904653	3372-2302

"B" CABLE

ITEM*	DESCRIPTION	CDC P/N	3M P/N
5	Connector (26 pos)	65853402	3399-3000
6	Connector Pull Tab	92004801	3490-2
7	Flat Cable (26 pos) with ground plane and drain wire.	95028509	3476-26

"B" Cable Mating Receptacle on Unit or Controller.

ITEM*	DESCRIPTION	CDC P/N	BERG P/N
8	26 pin, vertical header	96752044	65610-126

SMD I/O CABLE CHARACTERISTICS

"A" Cable

Type: 30 twisted pair, flat-cable
 Twists per inch: 2
 Impedance: 100 ±10 ohms
 Wire Size: 28 AWG, 7 strands
 Propagation time: 1.6 to 1.8 ns/ft (0.49 to 0.55 ns/m)
 Maximum cable length: 100 ft (30.48 meters) cumulative
 Voltage Rating: 300 V rms

"B" Cable (with ground plane)

Type: 26 conductor, flat cable with ground plane and drain wire
 Impedance: 65 ohms (3M P/N 3476-26)
 Wire Size: No. 28 AWG, 7 strands
 Propagation time: 1.5 to 1.8 ns/ft (0.46 to 0.55 ns/m)
 Maximum cable length: 50 ft (15.24 meters)
 Voltage Rating: 300 V rms

		PC	SPEC. NO.	SHEET	REV.
		A	77711094	54	A

PRODUCT SPECIFICATION - 9457 Lark Micro Unit

10.3 COLOR OPTIONS

The Lark Micro Unit is available in two standard colors, either CDC black or gray. These colors are molded into the plastic front door and lower dress panel. If a contrasting effect is desired standard appliques (in the same basic colors) are available for the front door i.e., a black base could have gray appliques applied to door and vice versa. Either one or both of the appliques may be specified. The lower dress panel always remains the standard base color as molded. Reference Figure 25 illustrating standard black base with both gray appliques. Special user color requirements can be handled by optional appliques whose colors are custom matched from a user supplied paint chip.

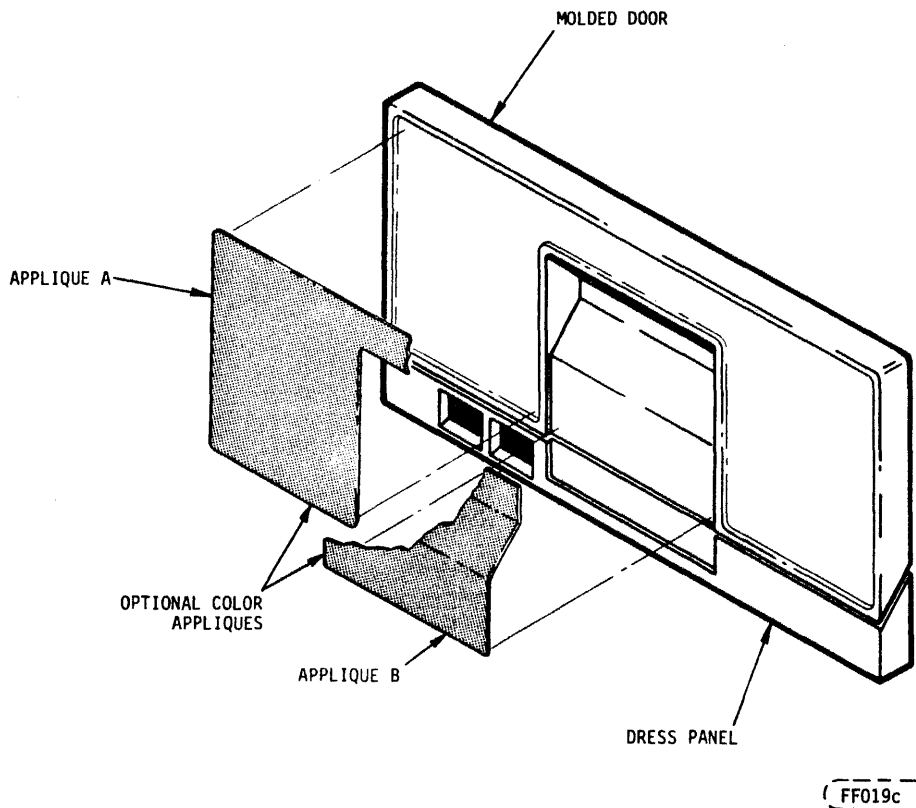

Figure 25. Color Options

		PC	SPEC. NO.	SHEET	REV.
		A	77711094	55	A

PRODUCT SPECIFICATION - 9457 Lark Micro Unit

10.4 MICRO COMPUTER STATUS DISPLAY

A micro computer status display option is available to allow an operator visual indication of micro computer status codes. This is accomplished via a pair of hexadecimal displays on the front lower dress panel opposite the operator controls. In the event of a drive fault condition, code/codes (up to sixteen) will be displayed allowing fault diagnosis based on an interpretation of these codes. This option may be ordered from the factory or installed in the field at a later time.

COLOR	MOUNTING	PART NO.
GRAY	HORIZONTAL	77666439
GRAY	VERTICAL	TBD
BLACK	HORIZONTAL	TBD
BLACK	VERTICAL	TBD
MICRO COMPUTER STATUS DISPLAY OPTIONS		

This option also includes an audible warning to the operator if the front door remains open for 2 minutes or longer.

A front panel with the status display option is shown in Figure 26.

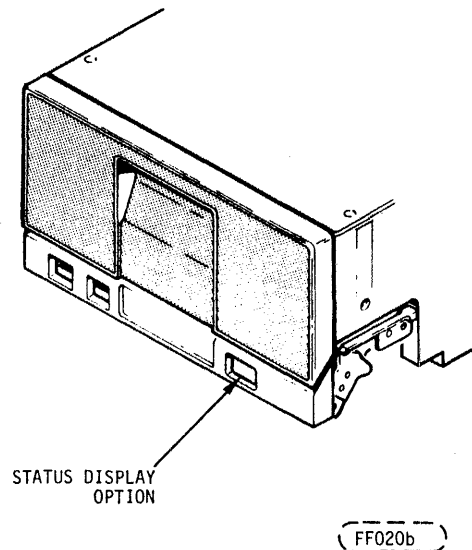

Figure 26. Front Panel with Status Display Option

		PC	SPEC. NO.	SHEET	REV.
		A	77711094	56F	A

PRODUCT SPECIFICATION - 9457 Lark Micro Unit

11.0 ACCESSORIES

The following accessories may be ordered for the Lark Micro Unit.

- Data Cartridge TBD
- Installation and Operation Instructions Volume I 77711044
- On Site Maintenance Manual Volume II 77711050
- Lark Operators Guide 77683742
- Terminator (SMD Interface Applications) 75886100
- Data Cartridge Product Specification 64717100
- Flat Cable Interface Specification (SMD) 64712400
- Model 9050 Intelligent Control Module △ 1

△ 1 Designed for adaption of LDI Interface to CDC ISI (Intelligent Standard Interface) at Host End. Basically a sophisticated disk controller with Buffering, Error Correction Codes, etc. Reference specification number 77711095.

TECHNICAL INQUIRY

FROM: NAME _____

ADDRESS _____
CITY _____
STATE _____ ZIP _____

For additional information
contact:

**Control Data Corporation
10321 West Reno Avenue
Oklahoma City, OK 73130**

**ATTN: APPLICATIONS
ENGINEERING
OKM 154**

DOCUMENT: TITLE/NUMBER/REVISION _____

COMMENTS: _____

STAPLE

STAPLE

FOLD

FOLD

BUSINESS REPLY MAIL
No Postage Stamp Necessary If Mailed in the United States

POSTAGE WILL BE PAID BY

CONTROL DATA CORPORATION

10321 West Reno Avenue
Oklahoma City, Oklahoma 73130

ATTN: APPLICATIONS ENGINEERING OKM154

FIRST CLASS
Permit Number 1332
OKLAHOMA CITY,
OKLAHOMA



CUT ALONG LINE

FOLD

FOLD