

SPECIFICATION FOR MODEL 5045-I510

DISCFILE®

NO. 102408

DATA PRODUCTS CORPORATION

8535 WARNER DRIVE

CULVER CITY, CALIFORNIA

Specification Approval:

J. J. Weiselman

Revision A 6/25/66

Date: 10 June, 1966

P

TABLE OF CONTENTS

<u>Paragraph</u>	<u>Title</u>	<u>Page</u>
1.0	Scope	1
2.0	Requirements	1
2.1	Unit Contents	1
2.2	Physical Size	1
2.3	Weight	2
2.4	Compressed Air Supply Requirement	2
2.5	Environment	2
2.6	Cooling and Air Filtering	2
2.7	Power	3
2.8	Packaging and Cable Entry	3
2.9	Color	3
2.10	Reliability and Product Life	3
2.11	Disc Rotational Speed	3
2.12	Storage Capacity	4
2.13	Physical Mechanization	4
2.14	Data Organization	5
2.15	Control Tracks	7
2.16	Dual-Channel Feature	8
2.17	Write Lockout Feature	9
2.18	Transfer Rate	9
2.19	Head Switching Time	9
2.20	Access Times	9
2.21	Read/Write Tolerances	10
2.22	Interface - Control Signals and Sequences	12
2.22.1	File Power On (Controller to File)	12
2.22.2	Operable (File to Controller)	12
2.22.3	Alarm (Buzzer)	13
2.22.4	Select-and-Transfer (Controller to File)	13
2.22.5	Address Accepted (File to Controller)	13
2.22.6	Busy (File to Controller)	13
2.22.7	Head Address Bus (Controller to File)	13
2.22.8	Read Address (Controller to File)	14
2.22.9	Address Fixed Head Enable (Controller to File)	14
2.22.10	Write Enable (Controller to File)	14
2.22.11	Write Data (Controller to File)	14
2.22.12	Read Data Bus (File to Controller)	15
2.22.13	Clock Bus (File to Controller)	15
2.22.14	Sector Bus (File to Controller)	15
2.22.15	Write Lockout (File to Controller)	16
2.22.16	Clear (Controller to File)	16
2.22.17	Address Stored (File to Controller)	16
2.22.18	Channel Select (Controller to File)	16
2.22.19	Confirmed (File to Controller)	17
2.22.20	Positioning Error (File to Controller)	17
2.22.21	Channel Connect (Controller to File)	17
2.22.22	Unit Number Bus	17
2.22.23	Fixed Head Address Bus (Controller to File)	18
2.23	Interface - Signal Cable Definitions	18
2.23.1	Controller to File	18
2.23.2	File to Controller	18
2.24	Signal Line Characteristics	19



TABLE OF CONTENTS (Cont)

<u>Paragraph</u>	<u>Title</u>	<u>Page</u>
2.25	Interface Connectors and Wiring (Controller To File)	21
2.26	Acceptance Tests	21
2.26.1	Error Definitions	21
2.27	Design Objectives	21
2.27.1	Incomplete Operation Error Rate	22
2.27.2	Reading Error Rate	22
2.27.3	Writing Error Rate	22
2.27.4	Failure Rate	22
2.28	Error Rate Acceptance Criteria	22
2.28.1	Incomplete Operation Error Rate	22
2.28.2	Reading Error Rate	22
2.28.3	Writing Error Rate	22
2.28.4	Failure Rate	22
2.29	Marginal Checking	22
2.29.1	Reed Relay Check	22
2.29.2	Off-Track Margin Test	22
2.29.3	Positioner Current Monitor	23
2.30	Maintenance	23
2.30.1	Scheduled Maintenance	23
2.30.2	Unscheduled Maintenance	23
2.31	Spare Parts	23

LIST OF ILLUSTRATIONS

<u>Figure</u>	<u>Title</u>	<u>Page</u>
1A/1B	Standard and Dual Switch Configurations	8A
1.	Average Motion Time	11
2.	Current Mode Interface Logic	20

LIST OF TABLES

<u>Table</u>	<u>Title</u>	<u>Page</u>
1.	Typical Sectoring Arrangements	6
2.	Addressable Bit Storage Capacity	7
3.	Transfer Rate	9



SPECIFICATION FOR MODEL 5045-~~I510~~ DISCFILE®

1.0 SCOPE

This document is the technical specification for a large capacity random-access storage device for use with digital computers. This device is referred to herein as a Disc Unit or DISCFILE®. A unique feature of this device is the dual-channel feature (see paragraph 2.17), which provides for simultaneous communication with two independent computers or with both channels of a dual-channel computer. The two channels may simultaneously perform any combination of seek, read or write, the only restriction being that both channels may not operate upon the same group at the same time.

In the standard configuration, a Controller interface is permitted access to only one of the two channels in any Disc Unit. The optional dual-switch feature permits either access channel to be connected to either Controller interface. The 5045-~~I510~~ is interface compatible with both the Data Products C510 and C511 Control Units.

2.0 REQUIREMENTS

2.1 Unit Contents

The Disc Unit contains 32 magnetically-coated data discs rotating on a common shaft. Data is recorded on the surfaces of the discs by read/write heads which are moved to a selected position by magnetically-actuated devices called positioners. The Disc Unit contains the discs, read/write heads and positioners, selection matrices for position and read/write head, write and read amplifiers, write lockout switches, and positioner power controls. When fixed heads are used an additional data disc is included.¹

An external source of compressed air may be supplied to the Disc Unit. A compressor, which is located external to the Disc Unit, is also supplied. A fifty-foot length of cable and air hose is supplied for the compressor. Either air supply may be used to land the heads.

All power sequencing circuitry necessary to automatically put the Disc Unit into operation or shut it down is in the cabinet. The sequencing may be initiated internally in a test mode or externally from the Controller.

2.2 Physical Size

Length - 68-1/2"
Height - 70"
Width - 36-1/2"

1 - Fixed heads will be supplied as an extra-cost option.



2.3 Weight - 3,450 pounds

2.3.1 Floor Loading - 207 lbs./square foot

2.3.2 Pad Loading - 435 lbs./pad

2.3.3 Shipping Weight

Add approximately 300 lbs. for necessary equipment and packaging.

2.4 Compressed Air Supply Requirement

2.4.1 Air pressure: 40 to 180 psi.

2.4.2 Volume: 12 cfm minimum

2.4.3 Filtration: External water trap and 10 micron filter.

NOTE

Recommended filtration media:
Perfecting Service Company
Filter F300-A with
Cartridge F-113A

2.5 Environment

2.5.1 Operating

Temperature: 60°F(15°C) minimum to 85°F(30°C) maximum.
Relative Humidity: 20% minimum to 80% maximum.

2.5.2 Storage and Shipping

Temperature: -20°F(-28.5°C) minimum to 150°F(65°C) maximum.
Relative Humidity: 98% maximum.

2.6 Cooling and Air Filtering

The Disc Unit is cooled by ambient air drawn in through the top of the unit and passes 1000 cubic feet per minute of filtered air. The equipment contains filters which take out 99% of all particles 5 microns or larger.



2.7 Power

- 2.7.1 The dp/f 5045 DISCFILE unit requires 6.5 kw, three-phase, a.c. power. The file can be supplied to operate from either of 208 or 415 volts, $\pm 10\%$, at either 50 cps or 60 cps, ± 1 cps line frequency.
- 2.7.2 The voltage and frequency variations specified above may be either transient or steady-state. When starting up, the disc motor is driven by a wye configuration to limit the current. At about 800 rpm, the input is switched to delta. The disc motor draws a maximum of 35 amps for no more than 5 seconds.
- 2.7.3 The Disc Unit contains its own DC power supplies for positioner power and the internal logic and switching circuitry.

2.8 Packaging and Cable Entry

The Disc Unit is totally enclosed with a minimum of functional trim; access is gained through simple sheet metal doors at the sides of the unit and removable panels at the top.

Cable entry is through the base of the unit.

2.9 Color

The Disc Unit shall be delivered with either a primed coat of zinc chromate or with Data Products Corporation standard colors. Other colors optional.

2.10 Reliability and Product Life

2.10.1 Reliability

Each part of the system is inspected and tested prior to final assembly, and each major assembly is tested when integrated with the system. The magnetic recording medium is guaranteed against failure due to material or workmanship for the warrantable life of the equipment.

2.10.2 Equipment Life

The system has a design life of at least three years before major overhaul is required, assuming that proper scheduled maintenance has been performed.

2.11 Disc Rotational Speed

The discs are driven at a rotational speed of 1200 rpm (1000 rpm for 50 cps) nominal. Induction slip may account for a rotational speed decrease of not more than 5%.



2.12 Storage Capacity

The total storage capacity of the file is (based on outer zone clock track of 62,224 bits) 764,608,512 bits including both data and addressing, synchronizing and alignment tolerance bits. The latter are not directly addressable as data. (Refer to 2.14.4 for addressable storage capacity of the file.) The total capacity may vary when the number of bits per track are adjusted to accommodate special formats.

When fixed heads are utilized, the total storage capacity is increased by 4,480,128 bits.

2.13 Physical Mechanization

Data is stored in circular tracks on both surfaces of rotating 31-inch diameter discs coated with magnetic material. The tracks on each recording surface are accessed for reading or writing by means of flying heads mounted in fixed positions on a movable positioner. A single positioner is associated with each disc.

2.13.1 Heads per positioner.

There are 8 heads per positioner. Four heads are used for the upper surface and four for the lower surface.

2.13.2 Positions per positioner

Each positioner may be addressed to any of 64 radial positions on a disc. The nominal track radius for the innermost position will be 5.0 inches for the inner zone and 9.8 inches for the outer zone.

2.13.3 Tracks per position

Eight tracks are accessed at each position, since each of the eight heads accesses its own track. This makes a total of 512 tracks on each disc, 256 for each surface.

2.13.4 Discs per file

There is a total of 34 discs, 32 discs for data storage and two baffle discs. One of the baffle discs, called the control disc, contains timing information used for control purposes in the Disc Unit and in the Controller.

2.13.5 Fixed Head Option

When the fixed head option is selected, an additional data disc is added immediately above the bottom baffle disc. A maximum of three fixed head assemblies may be used. Each fixed head assembly accommodates a maximum of 32 heads, 16 accessing the top surface of the disc and 16 accessing the bottom.



2.14 Data Organization

2.14.1 Track Zones

The tracks on each disc are separated into two groups in accordance with their location on the disc. These groups are referred to as inner zone and outer zone. Each zone contains 256 tracks, of which 128 are on the upper surface and 128 are on the bottom surface. Two of the four heads on each surface access outer zone tracks, and two access inner zone tracks.

The zoning is significant because the effective speed at which the disc surface passes under the read/write heads decreases greatly from the outermost tracks to the innermost tracks. To keep the recorded bit density more nearly the same for all tracks, the frequency of bit recording for inner zone tracks is less than that for the outer zone.

2.14.2 Sectoring

Tracks on each disc are divided into equal length sectors, each storing a single record. Because of the difference between inner and outer zone recording frequencies, inner zone tracks contain fewer sectors than those in the outer zone. The number of sectors is normally given per track pair, a pair consisting of one inner and one outer zone track. The sector format is established by the number of coded sector characters recorded on a single track on the control disc.

The sectoring arrangement is selected by the customer when a machine is ordered and is determined by the desired record length. The fixed head disc, if selected, uses the same sectoring as the other discs. Since only a single record is stored in each sector, the number of sectors per track pair determines the total record storage capacity of the file. At each position of the positioner, all records on a group of eight tracks can be accessed by switching among heads on the positioner arm. Record storage capacities for some typical sectoring arrangements are illustrated in Table 1.

A fixed head disc using the full complement of 96 fixed heads can store the number of records equal to 12 positions.



TABLE 1. TYPICAL SECTORING ARRANGEMENTS

RECORDS PER	SECTORS PER TRACK PAIR			
	12	24	25	48
INNER ZONE TRACK	4	8	9	16
OUTER ZONE TRACK	8	16	16	32
POSITION	48	96	100	192
DISC	3,072	6,144	6,400	12,288
DISCFILE	98,304	196,608	204,800	393,216

2.14.3 Address Headers

At the beginning of each sector is a pre-recorded address called a header, which includes bits identifying the disc, position, and sector address of the record contained in that sector. The header address may, as an alternative, be considered to identify the record contained in the following sector. This alternative allows the Controller sufficient time to read and evaluate the header address before initiating a data transfer for the record identified by that address.

The exact location of the header address within a sector, together with instructions for writing new header addresses, is given in paragraph 2.21.

2.14.4 Addressable Data Storage Capacity

The addressable data storage capacity is a function of the record length utilized in a file. There are approximately 300 bits required in each sector for address headers, synchronizing, and tolerance to allow for spacing between read/write and erase gaps and maximum skew (skew is a positioning error tangential to a track). Addressable data storage therefore decreases as the number of sectors per track pair increases. Table 2 illustrates bit storage capacity of a record, track pair, position, disc, and a complete DISCFILE unit, as a function of various typical sectoring arrangements.



TABLE 2. ADDRESSABLE BIT STORAGE CAPACITY

BITS PER	SECTORS PER TRACK PAIR			
	12	24	25	48
RECORD	7,450	3,570	3,300	1,616
TRACK PAIR	89,400	85,680	82,500	77,568
POSITION (THOUSANDS)	358	343	330	310
DISC (THOUSANDS)	22,886	21,934	21,120	19,857
DISCFILE (THOUSANDS)	732,365	701,880	675,840	635,437

2.15 Control Tracks

There are four independent sets of control tracks. In the standard file, the set consists of one track which contains clock, sector and index information. A second track per set is available as an option if the 2 to 1 frequency ratio cannot be utilized efficiently. These tracks are located on the control disc and are pre-recorded by Data Products Corporation. Data Products Corporation retains records of customer control track requirements to enable recording of new control discs.

2.15.1 Standard Interface (Without Internal Confirmation)

The standard control track contains clock information, sector marks used to locate records, and an index mark. The marks are discriminated and supplied over the Sector Bus as the following 4-bit character codes:

Index Character - 1111
 Outer Zone Sector Character - 1011
 Inner Zone Sector Character - 1101

The Index Character coincides with an outer zone and inner zone character and hence only the Index Character code is written. When outer zone sectoring is exactly twice that of the inner zone, each inner zone sector mark will coincide with an outer zone sector mark. In this case only an inner zone sector mark is written.

A single clock frequency is written which is the outer zone clock. The outer zone clock is divided by two to obtain the inner zone clock.

When the outer to inner zone clock ratio of 2 to 1 cannot be used effectively, an additional control track containing a second frequency is required. When the outer/inner sectoring is other than a 2 to 1 ratio, inner zone sector marks will not coincide with



outer zone sector marks. The marks for each zone are then written equidistant about the control track. The only criteria is that a minimum of four zeros is recorded between consecutive characters.

2.15.2 Internal Confirmation

When the Internal Confirmation option is used, the index and sector marks are decoded in the Disc Unit. In this case, the index mark is supplied over the Sector-1 line and the sector marks for the zone currently being operated upon are supplied over the Sector CLK line.

The duration between sector marks is dependent upon the head currently selected. The Disc Unit sector decode circuits will respond to a change of zones within one microsecond. For a continue operation, the Controller should switch heads near the end of a sector in order to prevent spurious sector pulses.

2.16 Dual-Channel Feature

Facility for dual-channel operation is provided by dual interface, dual read/write channels, and independent position selection and power switching matrices for each positioner.

The 32 positioners in each DISCFILE are separated into 4 groups, each containing 8 positioners. The groups are designated I, II, III, and IV. The only restriction on dual-channel operation is that both channels cannot simultaneously access positioners in the same group. Positioners are numbered from the bottom up and are grouped as follows:

GROUPS

I	II	III	IV
0, 4, 8, 12	1, 5, 9, 13	2, 6, 10, 14	3, 7, 11, 15
16, 20, 24, 28	17, 21, 25, 29	18, 22, 26, 30	19, 23, 27, 31

When fixed heads are used, only one channel may address a fixed head in a single DISCFILE at any one time. However, a fixed head may be accessed for reading or writing by a channel which has just set a movable positioner in motion; i.e., accessing a fixed head disc does not automatically remove power from a positioner.

2.16.1 Dual-Switch Feature

In the standard configuration, an access channel consists of an interface and the access channel logic. With the dual-switch feature, the circuits are arranged so that each interface may be switched to either access channel logic circuits. Figure 1A illustrates the standard configuration where Interface 1 and 2 are tied to access channels A and B respectively. Figure 1B illustrates the interconnections using the Dual-Switch feature. The Controller prevents both interfaces from connecting to the same access channel simultaneously. In addition, the Disc Unit is interlocked to prevent either channel from being accessed by both interfaces simultaneously.



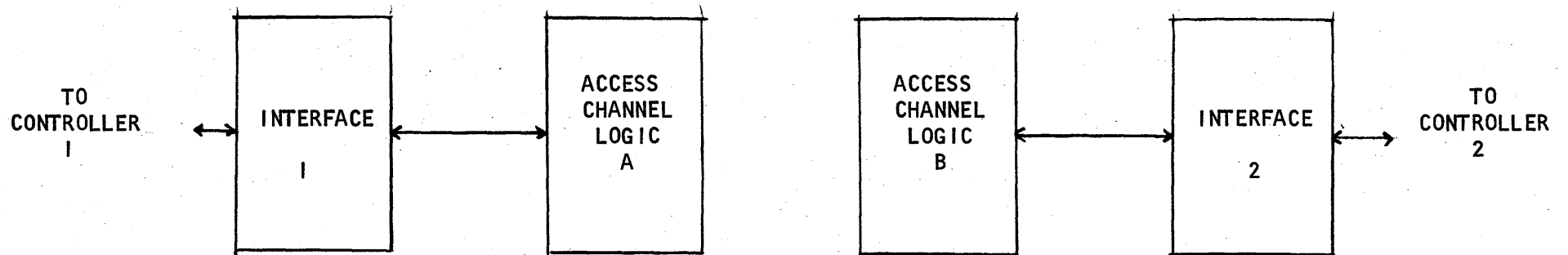

FIGURE 1A. STANDARD CONFIGURATION

8A

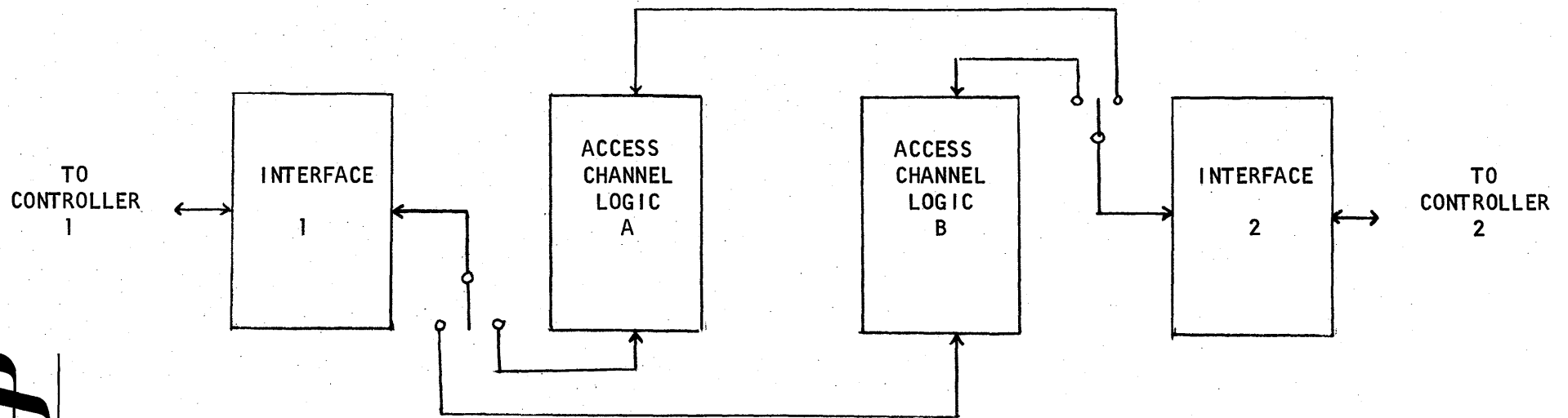

FIGURE 1B. DUAL-SWITCH CONFIGURATION



2.17 Write Lockout Feature

The DISCFILE is provided with a set of 32 switches in a key-locked box to provide a means by which one or any combination of discs may be protected against being written upon or erased. A switch is also provided for locking out the fixed head disc in machines using the fixed head option. The Controller is notified by an appropriate signal when a locked-out disc is addressed.

2.18 Transfer Rate

Transfer rates are determined by the number of bits on each clock track and the disc rotational speed (see 2.11). Outer zone clock bits normally total 62,224; inner zone clock bits total 31,112.

Bit-to-bit timing may vary as much as ± 30 percent and is found by the following formula.

$$\text{Bit-to-bit period} = \frac{1}{\text{Disc RPS} \times \text{Number of clock bits}}$$

Transfer frequencies and bit-to-bit timing for both 50 cps and 60 cps power input are illustrated in Table 3.

TABLE 3. TRANSFER RATE

POWER	TRANSFER FREQ (KC)		BIT-TO-BIT TIMING (USEC)	
	OZ	IZ	OZ	IZ
60 cps	1200	600	0.84	1.67
50 cps	1000	500	1.0	2.0

2.19 Head Switching Time

When switching from head to head on an arm (in order to access all eight tracks at a position), the total head switching time including read amplifier recovery is approximately 50 microseconds.

2.20 Access Times

The time required to access data depends on the location of the record relative to the previously accessed record. The components of access time are power switching time, motion time, confirmation time and latency. All components of access time must be included unless the new record is at the same position of the same disc as the last record accessed on that channel and the positioner still has power on, in which case the access time is merely rotational latency. When a fixed head is selected, power switching and motion times are not required.



2.20.1 Power Switching Time

If the position of a positioner is changed, or if power has been removed from the positioner, then power switching time must be included in the access time. The power switching time is approximately 6 ms if power is off when the new position and/or positioner is addressed and approximately 19 ms when power is on.

2.20.2 Motion Time

Motion time for a given stroke length is defined as the time starting at the end of the power switching time to the first time when address headers at the selected position may be reliably read for confirmation. The maximum motion time will not exceed 225 milliseconds.

2.20.2.1 Stroke Length Timing

The average motion time for any stroke length for any positioner will be consistent with the values shown in Figure 1. (The allowance for short strokes to the end of the positioner is a nominal value, not a maximum.)

2.20.3 Confirmation Time

Because of the "soft stop" characteristic of the DISCFILE positioning mechanism, a certain amount of oscillation occurs about the addressed position. A procedure called track confirmation must be performed to determine when the positioner has settled sufficiently for reliable data transfer. This procedure consists of attempting to read address headers (disc and position portion only is sufficient) from the addressed head. The positioner may be considered settled when contiguous headers have been successfully read for a period of 39 milliseconds.

2.20.4 Latency Time

Latency time must be included in the access time. Latency will vary from a minimum of 0.0 msec to a maximum of one disc revolution (52 msec for 60 cps power, 63 msec for 50 cps power; both figures include 5% induction slip). Average latency is equal to one-half a disc revolution.

2.21 Read/Write Tolerances

Writing of headers and data and subsequent reading must take into account various mechanical tolerances inherent in the construction of the arms and heads. There is a physical space of 62 mils between the erase gap and the read/write gap. In addition, the arms supporting the heads are subject to an amount of skew.

When writing headers, the Controller will use the sector control track index mark to define the beginning of a track (in order to locate the first sector) and the subsequent sector characters to define the start of each new sector. The Controller may then count



The probability is not more than 0.05 that the time for any stroke length will vary from the average time by more than ± 30 msec.

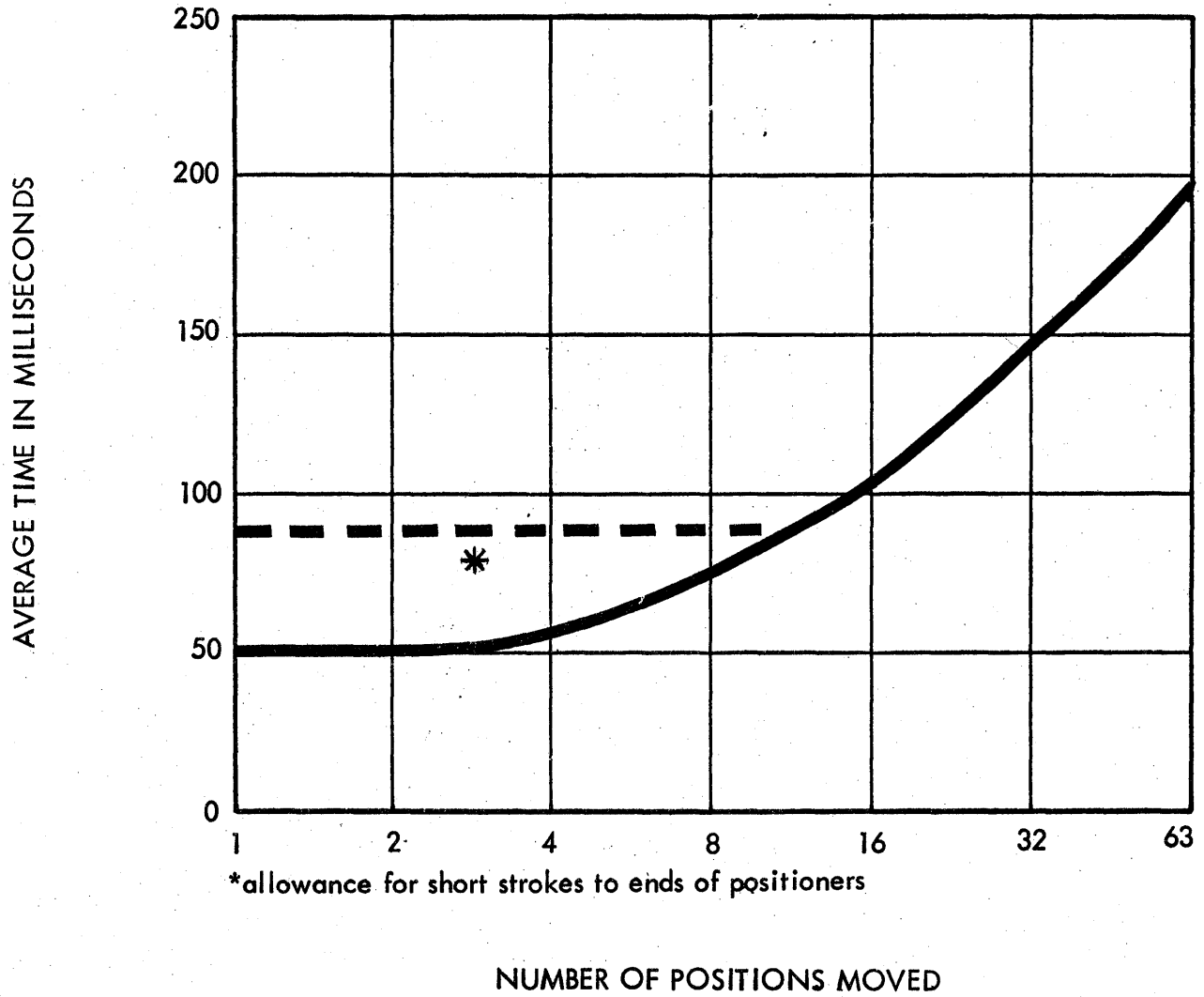

FIGURE 1. AVERAGE MOTION TIME



the number of clocks occurring after the last bit of each sector character to locate the specified areas for writing and reading. The number of clocks counted will depend upon the frequency of the recorded clock track.

When writing headers, ZEROS shall be written from the sector mark to ensure proper erasure and to account for possible skew. A minimum of 135 mils shall be provided between the last bit of the sector character and the synchronizing bit preceding the initial bit of header. A minimum of 87 mils written with all ZEROS shall be provided between the last bit of header and the synchronizing bit preceding the first record data bit written.

It should be noted that when writing either header or data, there must be a pad of four ZEROS after the last bit written. The pad at the end of the header shall be preserved; that is, writing of ZEROS preparatory to writing of data shall not begin until after the end of the header pad.

A minimum of 30 mils shall be provided between the last bit of data written and the last bit of the next sector character.

When reading headers, the Controller shall provide a delay of 106 mils after the last bit of sector character before enabling reading in order to examine the track for the header sync bit.

When reading record data, the Controller shall provide a delay of 78 mils after the last bit of header before enabling reading in order to examine the track for the record sync bit.

2.22 Interface - Control Signals and Sequences

Both access channels contain an identical, independent signal interface. In this way, two computers may independently receive and transmit all the necessary signals.

2.22.1 File Power On (Controller to File)

This contains two lines which are short-circuited to energize the DISCFILE. One line carries 24 VAC which is supplied by the file. The file power on lines are open-circuited to turn the file off. The file may be turned on independently from either access. Both power-on lines must be open-circuited to turn the file off.

2.22.2 Operable (File to Controller)

This signal is supplied over a twisted-pair line and is either open or shorted by contact closure. When the DISCFILE is operable and available to receive commands, the relay contacts close. This signal is generated approximately 6 minutes after a file power on command. The operable signal will not be supplied if: the file is in a test mode; both channels remove the file power on signal; the positioner power supply output, disc rotational speed or dc power fall below normal; or a malfunction is indicated in the air supply system.



2.22.3 Alarm (Buzzer)

The Alarm condition exists if the internal temperature of the Disc Unit reaches the alarm level (104°F). If the Alarm condition exists, an audible alarm will be sounded from the unit. The audible alarm may be turned off by throwing the Disc Unit ALARM switch to OFF. When the Alarm switch is in the OFF condition, the unit is taken out of the operable condition. The alarm condition will also be supplied as a contact closure, if desired.

2.22.4 Select-and Transfer (Controller to File)

The Select-and-Transfer pulses are used to condition the access channel to accept the address data presented on the write data bus. The pulse train consists of a total of 13 pulses. The first pulse clears an internal register. The first pulse is followed by a data ONE on the write data bus. A second Select-and-Transfer pulse is sent. The address is then sent on the write data bus in bit serial form. Each bit transmitted is followed by a Select-and-Transfer pulse. The response to the train of pulses is Address Accepted. The response will occur within 5 microseconds after the last pulse of the train.

2.22.5 Address Accepted (File to Controller)

A signal generated in response to and within 5 microseconds after the last Select-and-Transfer pulse. This signal indicates that the new address has been accepted, and it will remain active until a Select and Transfer or Clear pulse is received.

2.22.6 Busy (File to Controller)

A signal indicating that the addressed area is currently under control of the other channel. The busy signal is generated within 5 microseconds after the last Select-and-Transfer pulse. The busy signal remains active as long as the alternate channel is addressing the busy area. Should the alternate channel release the area, the busy signal goes inactive and the channel proceeds to select the disc. The busy signal goes inactive when a new Select-and-Transfer, or a Clear pulse is received.

The busy signal also goes active when a channel attempts to address a fixed head while a fixed head is being accessed by the alternate channel.

2.22.7 Head Address Bus (Controller to File)

The head address bus consists of 3 signal lines which select one of eight heads on a positioner for reading or writing. The bus must be active during reading or writing from the selected head.

When addressing fixed heads, the head address bus is used to select one of eight heads in the group determined by the fixed head address bus.



2.22.8 Read Address (Controller to File)

The Read Address pulses are used to condition the access channel to transmit the disc and position address currently being stored. The stored address is transmitted bit serially over the Read Data Bus. The Read Address pulses are accepted only when the Address Stored level is active.

The first Read Address pulse clears an internal register. The second transfers the stored address to the internal register. Each succeeding pulse shifts out a bit to the Read Data Bus. Thus, a total of 13 thirteen pulses are used. Two are used to initialize and eleven are used to transmit the eleven address bits.

2.22.9 Fixed Head Enable (Controller to File) (Optional)

This signal instructs the Disc Unit to utilize the Fixed Head Address Bus and the Head Address Bus to select the appropriate fixed head. Note that a fixed head access does not disturb a power-on condition in either channel. This line also instructs the channel to utilize all applicable Controller commands to operate on the fixed head track.

2.22.10 Write Enable (Controller to File)

A signal on this line conditions the channel to write data. When this signal goes active, the file will begin to write ZEROS. A data ONE is written each time a pulse is received over the Write Data line. Write enable also conditions the file to process data from the output of the write amplifier and route the data to the Controller over the read data bus. The absence of write enable allows the file to read header or data from the disc and transmit it to the Controller.

The signal may not be applied until confirmation is complete and the selected head is entering the desired record. After write enable, the write circuitry requires approximately 10 microseconds to erase reliably.

The writing mode is terminated by removing write enable. Removal of write enable must be delayed sufficiently to allow the file to complete writing the record and the minimum 4-bit pad (see paragraph 2.21) following the record. An additional delay equal to one bit is required because the write circuits in the file delay write data one bit-time.

2.22.11 Write Data (Controller to File)

The write data bus consists of one signal line for data ONES used to transfer data to the file at the selected zone clock rate. During the write operation, the Controller must gate the delayed CLK pulses (2.22.15) over the Write Data line within 0.4 microsecond. This time delay includes the propagation time of the line



and the Controller gating delay and is measured at the file interface. Should the Controller require more than 0.4 microseconds to respond, the CLK pulses can be used to gate the Write Data.

The write data bus is also used to transfer the input address to the access channel. This transfer occurs during the Select-and-Transfer pulse train. The address is transferred in the same manner as write data except it is not clocked with the Clock pulses and consists of 11 bits preceded by a sync bit ONE.

2.22.12 Read Data Bus (File to Controller)

The read data bus consists of two signal lines, one each for ZEROS and ONES, used to transfer data from the file during a read operation. The data pulse period may vary $\pm 30\%$ between any two consecutive pulses from the average transfer rate (see paragraph 2.18).

During write operation the read data bus is used to transfer write verify signals back to the Controller. Write verify signals are generated in response to write current, and therefore provide a means of checking accuracy of data being written. The delay between a CLK pulse gated to the Controller and a write verify pulse derived from the write data bit pulse is approximately two clock periods measured at the file interface.

The read data bus is also used, in response to the Read Address pulse train to transfer the address currently stored by an access channel to the Controller. This address is gated to the Controller a bit at a time with the Read Address pulses.

2.22.13 Clock Bus (File to Controller)

The clock bus consists of two signal lines CLK and delayed CLK and is used to transfer clock information to the Controller. Clock pulses are generated from information read from the clock tracks on the file control disc.

The frequency of the clock pulses transmitted to the Controller is determined by the zone in which the addressed head is located. The clock track (inner zone or outer zone) selected is determined by the head selected (2.15). Note - Outer zone clock pulses are sent to the Controller when no head is currently selected.

2.22.14 Sector Bus (File to Controller)

2.22.14.1 Standard Interface (Without Internal Confirmation)

The sector bus consists of two lines, designated Sector-I and Sector CLK, which are used to transfer sector information to the Controller. The sector information is generated from a single track located on the control disc. The sector-CLK line contains a train of pulses at a frequency of the outer zone clock. Pulses on the Sector-I line represent logic ONES and are sent in place of Sector-CLK pulse.



The sector information contains the index, outer zone and inner zone marks consisting of coded characters written at proper intervals along the circumference of the sector track. Coded characters used to identify sector and index marks are given in 2.15.1.

2.22.14.2 Internal Confirmation

When the internal confirmation option is exercised the index and sector marks are supplied as per 2.15.2.

2.22.15 Write Lockout (File to Controller)

Write lockout is used to notify the Controller that the selected disc is in a lockout or non-write status. This signal comes from the Write Lockout switches and will be a logic ONE for a non-write condition and ZERO for a write condition.

2.22.16 Clear (Controller to File)

This signal is used to interrupt the "position hold" state of a channel. The positioner power circuits in the file are designed so that power remains on, holding the heads at a selected position until the clear or select-and-transfer signals are received. Either of these signals will cause positioner power to be turned off.

2.22.17 Address Stored (File to Controller)

This level indicates that a disc and position address has been stored which will be used in the Disc Unit to select a positioner and a position of that positioner. The level then remains active as long as power is being applied to the positioner. When the level is inactive, it indicates that no power is being applied to a positioner from the channel.

The signal goes from active to inactive approximately 13 milliseconds after a clear pulse is received. If the signal has been inactive more than 13 milliseconds nominal, it goes active immediately after Address Accepted. If it is active and a new address is received, then it will go inactive in approximately 13 milliseconds for a few microseconds, and then go active again when the new address is stored in the register.

The Read Address pulses will only be responded to when the Address Stored level is active; (when the Address Stored level is not active, no power is being applied to a positioner).

2.22.18 Channel Connect (Controller to File) (Optional)

When using the Dual-Switch option, this signal connects the associated interface circuits to the desired access channel logic. An active level selects channel B and an inactive level selects channel A. The Dual-Switch logic is interlocked so that if a channel



is connected to an interface, it is not available and is interlocked to prevent its connecting with the other interface. This interlock is precautionary and a channel conflict condition should be monitored by the Controller before the address is issued.

2.22.19 Confirmed (File to Controller) (Optional)

This signal indicates that the selected positioner is settled on track, in the case of a moving-head address. This signal is available when the Internal Confirmation option is supplied with the DISCFILE.

The seek operation for a moving-head address begins as soon as the address is stored. The stored address is used to select a positioner, move that positioner to the selected position and select a head for reading headers. A sufficient number of headers on a given track are read to determine that the positioner is settled on the track. This is the earliest point in time that reliable reading or writing may be performed. The process of determining that the positioner is settled is called track confirmation.

When the track confirmation is finished, the Confirmed signal is sent to the Controller. The access channel remains in the confirmed state until a clear pulse or a new Select-and-Transfer.

For a fixed head address, Confirmed is supplied when the fixed head is selected.

2.22.20 Positioning Error (File to Controller) (Optional)

When the Internal Confirmation option is selected, track confirmation is performed within the Disc Unit. If track confirmation does not occur within 400 milliseconds after Address Stored and not Busy, then a positioning error exists. Under these conditions, the positioning error signal is issued instead of Confirmed.

2.22.21 File Select (Controller to File)

This signal is used in a system which utilizes more than one disc unit interface attached to the Controller. The receiver and driver signals may be so bussed that each signal is carried on a bus common to all attached interfaces. The File Select signal causes the circuits of a particular interface to be physically engaged with the bus. The access channel is usable 15 microseconds after File Select is issued.

2.22.22 Unit Number Bus (File to Controller)

This bus supplies the binary code representing the unit number of the Disc Unit. Two lines are normally supplied, but three will be supplied in case the option for allowing eight Disc Units on-line is provided. The signals are active whenever the channel is connected by File Select. The Unit Number is manually preselected by the operator.



2.22.23 Fixed Head Address Bus (Controller to File) (Optional)

This bus is used to address one of twelve groups of fixed heads, each group containing eight heads. The head address bus then selects one of eight fixed heads in the group.

4.22.24 Validate (File to Controller) (Optional)

This signal goes active with Confirmed and stays active as long as the channel remains confirmed. It goes inactive at the end of any header that does not agree with the stored disc and position information. The Validate signal returns to the active state when disc and position agreement is attained.

2.23 Interface - Signal Cable Definitions

2.23.1 Controller to File

The following 16 lines are provided for Controller to File communication.

<u>Signal Name</u>	<u>Cable Type</u>	<u>Signal Type</u>
File Power On	Twisted pair	Contact closure 24 vac from file.
File Select	One coaxial line	Logic level
Select-and-Transfer	Coaxial line	Pulse
Read Address	Coaxial line	Pulse
Head Address Bus	Three coaxial lines	Logic level
Fixed Head Enable*	Coaxial line	Logic level
Write Enable	Coaxial line	Logic level
Write Data Bus	Coaxial line	Pulse
Clear	Coaxial line	Pulse
Channel Connect*	Coaxial line	Logic level
Fixed Head Address Bus*	Four coaxial lines	Logic level

2.23.2 File to Controller

The following 17 lines are provided for File to Controller signals.

<u>Signal Name</u>	<u>Cable Type</u>	<u>Signal Type</u>
Operable	Twisted pair	Contact closure
Address Accepted	Coaxial line	Logic level
Write Lockout	Coaxial line	Logic level
Read Data Bus	Two coaxial lines	Pulse
Clock Bus	Two coaxial lines	Pulse
Sector Bus	Two coaxial lines	Pulse
Busy	Coaxial line	Logic level
Confirmed*	Coaxial line	Logic level
Positioning Error*	Coaxial line	Logic level
Address Stored	Coaxial line	Logic level
Unit Number Bus	Two coaxial lines (three optional)	Logic level
Alarm	Twisted pair	Contact closure
Validate*	Coaxial line	Logic level



2.24 Signal Line Characteristics

2.24.1 Interface signals are represented by either a contact closure, a pulse or a level.

2.24.1.1 Contact Closure Characteristics

The relay contact channels consist of a twisted-pair line connected across a relay contact. A logical ONE is represented by a closed relay contact and a logical ZERO is represented by an open line. In order to protect the relay contact and insure long life, the power drawn through the contacts shall not exceed 24 V at 2 amperes maximum.

2.24.1.2 Pulse Line Characteristics

The standard interface uses current levels and current pulses. The current is supplied from a positive voltage and is referenced at a nominal +6 volts for the transmitter and a +1 volt for the receiver. Simplified circuit diagrams of the transmitter and receiver are shown on the following page.

There are two standard current states. The LOW state is the quiescent state for pulses and is represented by less than two milliamperes but more than 0.5 milliamperes. The HIGH or active pulse state is represented by 9 ± 2 milliamperes. Transitions between the states should occur between 10 and 100 nanoseconds. A pulse should remain at the high state for more than 20 nanoseconds and should remain above the 50% level for between 80 and 200 nanoseconds.

2.24.1.3 Logic Level Characteristics

The logic level characteristics are the same as the pulse line characteristics except that levels are transmitted instead of pulses.



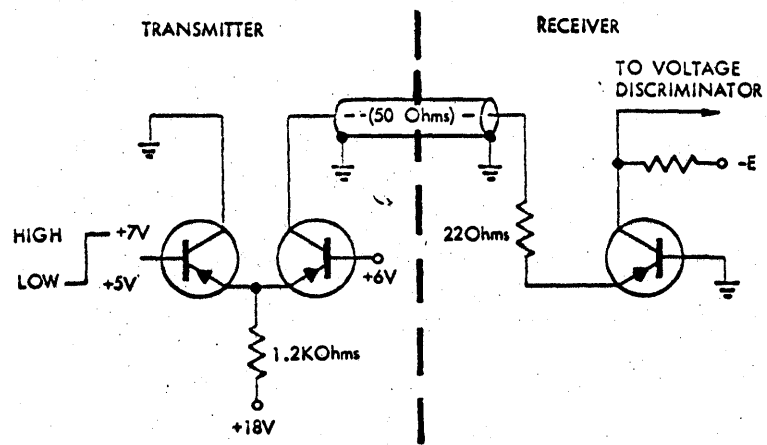

Current Mode Interface Logic

Figure 2



2.25 Interface Connectors and Wiring (Controller to File) (2 sets)

Interface connector specified below mate connectors mounted in the DISCFILE.

Input connector (Controller to File), Elco part number 00-8017-100-000-012, keyed '1' to '1'.

Interface wiring will be supplied when required.

2.26 Acceptance Tests

The DISCFILE shall be accepted at the Data Products Corporation plant after the test defined in the Data Products Corporation Test Specification has run for 48 hours. The error rate for acceptance is defined below.

2.26.1 Error Definitions

2.26.1.1 Incomplete Operation Error

The equipment is given a command not involving data transfer, and does not complete the operation (or an error is generated for a condition which is not a data error) and then the equipment completes the operation within three successive attempts.

2.26.1.2 Reading Error

A data error is detected or the equipment ceases to operate during data transfer in a read operation other than a write check and any of three repeated reading operations on the same record is error free.

2.26.1.3 Writing Error

A data error is detected or the equipment ceases to operate during data transfer in a writing operation or during the operation of reading data written during the test but not previously read, and a repeated writing operation on the same record is error free and yields data which may be read without error in a write check within three repeated attempts.

2.26.1.4 Failure

A condition or malfunction which causes errors and which can only be corrected by unscheduled maintenance.

2.27 Design Objectives

The design objectives of the system for field operation are as listed below.

NOTE

The following failure and error rates are design objectives for the equipment when operated in a typical commercial computer requirement.



2.27.1 Incomplete Operation Error Rate

Not more than 1 in 10^6 operation.

2.27.2 Reading Error Rate

Not more than 1 in 10^{10} data bits transferred.

2.27.3 Writing Error Rate

Not more than 1 in 10^{11} data bits transferred.

2.27.4 Failure Rate

Not more than 1 failure for 250 hours of cumulative file operation.

2.28 Error Rate Acceptance Criteria

2.28.1 Incomplete Operation Error Rate

Not more than 1 in 10^5 operations.

2.28.2 Reading Error Rate

Not more than 1 in 10^9 data bits transferred.

2.28.3 Writing Error Rate

Not more than 1 in 10^{10} data bits transferred.

2.28.4 Failure Rate

Not more than 4 during the acceptance test. If the replaced Component is a disc or positioner, the replaced assembly should be tested for 2 hours plus 1/32 of the test time accumulated when the failure occurs.

2.29 Marginal Checking

Marginal checking of certain sub-systems of the DISCFILE is provided. The techniques used depend on that part of the system which is being checked.

2.29.1 Reed Relay Check

The reed relays may be checked for marginal operation by utilizing the Reed Check switch. Operation of this switch causes the voltage to be reduced on the reed relay coils. If poor positioning results from the marginal voltage, the particular reeds may be isolated as being marginal.

2.29.2 Off-Track Margin Test

The read-write system may be tested under marginal conditions by causing the positioner to move off track. This is accomplished by causing an imbalance in the currents operating the positioner, with insertion of jumpers in banana plugs provided for this purpose.



2.29.3 Positioner Current Monitor

The current operating the positioner can be monitored with the positioner current meter. A low current meter reading indicates that the reed switch being used is marginal.

2.30 Maintenance

2.30.1 Scheduled Maintenance

Routing scheduled preventive maintenance procedures will normally require about 3 man-hours per 300 hours of operation. This maintenance should be performed by suitable trained and competent customer personnel. The schedule for routine preventive maintenance shall be in accordance with the preventive maintenance procedures recommended by the vendor, in the manual and in customer information bulletins.

2.30.2 Unscheduled Maintenance

The unscheduled maintenance will not normally exceed an average repair time of one hour per month per DISCFILE, if parts and maintenance personnel are available.

2.31. Spare Parts

Spare parts will be functionally interchangeable with like assemblies, subassemblies, and replaceable parts as found within the system. They must also be physically interchangeable, one with another. A list of spare parts will be supplied to the customer.

