

EK-LA100-PS-001

# LA100 Series

Pocket Service Guide

**digital**



# **LA100 Series**

## **Pocket Service Guide**

Prepared by Educational Services  
of  
Digital Equipment Corporation

Copyright © 1982  
by Digital Equipment Corporation  
All Rights Reserved

The reproduction of this material, in part or whole, is strictly prohibited. For copy information, contact the Educational Services Department, Digital Equipment Corporation, Maynard, Massachusetts 01754.

The information in this document is subject to change without notice. Digital Equipment Corporation assumes no responsibility for any errors that may appear in this document.

Printed in U.S.A.

The following are trademarks of Digital Equipment Corporation, Maynard, Massachusetts.

DEC	DECnet	OMNIBUS
DECUS	DECsystem-10	OS/8
DIGITAL	DECsystem-20	PDT
Digital Logo	DECwriter	RSTS
PDP	DIBOL	RSX
UNIBUS	EduSystem	VMS
VAX	IAS	VT
MASSBUS		

## CONTENTS

### INTRODUCTION

#### 1 TROUBLESHOOTING AND TESTING

1.1	General .....	1
1.2	Troubleshooting the LA100 .....	1
1.3	Power-Up Self-Test .....	3
1.4	Printer Self-Tests .....	3
1.5	Loopback Test .....	21

#### 2 FRU REMOVAL AND REPLACEMENT

2.1	General .....	27
2.2	Printhead Assembly .....	27
2.3	Printer Housing Cover .....	31
2.4	Platen Clutch/Gear Assembly .....	37
2.5	Bail Bar Assembly .....	39
2.6	Friction Assembly .....	39
2.7	Power Supply Assembly .....	42
2.8	Keyboard/Operator Control Panel Assembly .....	44
2.9	Logic Board .....	47
2.10	Printer Mechanism .....	52
2.11	Antibacklash Gear .....	52
2.12	Line Feed Motor Assembly .....	56
2.13	Servo Motor and Encoder Assembly .....	58
2.14	Pulley/Tension Assembly .....	58
2.15	Timing Belt .....	61
2.16	Ribbon Drive Cables .....	61
2.17	Carriage Assembly .....	64
2.18	Paper Out Detection Switch .....	66
2.19	Printhead Cable Assembly .....	70
2.20	Paper Low Jack Assembly .....	73

#### 3 LOGIC BOARD CONFIGURATIONS

3.1	General .....	75
3.2	Jumper Selectable Features .....	75
3.3	EIA Circuit Jumpers .....	75
3.4	DPS ROMs .....	77

**4 OPTION SERVICING**

4.1	General .....	79
4.2	LAX34-RL Roll Paper Holder Option .....	79
4.3	LAX34-AL Tractor Option .....	81
4.4	LAX34-LL Paper Low Detection Option .....	85
4.5	LAX34-CL 20 mA Current Loop Interface Option .....	89
4.6	LAX34-KL Numeric Keypad Option .....	94

**5 OPERATING FEATURES SUMMARIES**

5.1	General .....	97
5.2	SET-UP Features .....	97
5.3	Switch Selectable Features .....	104
5.4	Jumper Selectable Features .....	104

**6 RECOMMENDED SPARE PARTS LISTS**

6.1	General .....	113
-----	---------------	-----

**PHYSICAL/FUNCTIONAL DIAGRAM**

## INTRODUCTION

The LA100 Series Pocket Service Guide is used for all of the terminals in the LA100 family. This pocket service guide provides the following information:

- Troubleshooting to the field replaceable unit (FRU)
- FRU removal and replacement
- Jumper Configurations
- Option troubleshooting/removal and replacement
- Operator Reference Summary

There are 2 different terminals in the LA100 family; the Letterprinter 100 and the Letterwriter 100. The main difference between the two terminals is the keyboard assembly; Letterwriter 100 models have a complete keyboard assembly for data transmission and control. The Letterprinter 100 models have an operator control panel assembly for local control of selected printer functions.

### Notes, Cautions, and Warnings

Notes, cautions and warnings are used throughout this manual. Their definitions are as follows:

Note	Important message you should be aware of.
Caution	Information essential to prevent damage to the equipment or software.
Warning	Information essential to the safety of servicing personnel.

All cautions and warnings appear in red.

### TOOLS REQUIRED

The following tools are required to service the LA100 terminals.

Tools	Part Number
VOM (volt ohmmeter)	29-13510-00
Slotted screwdriver, 1/4 inch	29-10983-00
Slotted screwdriver, 5/16 inch	29-10960-00
Phillips screwdriver, #2	29-11005-00
Keycap puller	74-16355-00
Nut driver, 1/4 inch	29-10664-00
Nut driver, 5/16 inch	29-10673-00
Driver handle	29-10562-00
Needlenose pliers	
Scribe	None





1.1 GENERAL

This chapter provides the information needed to test and troubleshoot an LA100 terminal. Perform option troubleshooting only after the basic terminal is functioning properly. Refer to the Options chapter for option troubleshooting procedures.

General Troubleshooting Notes

1. This guide assumes that only one FRU has failed. Since there may be more than one failure at any time, symptoms may change as you replace FRUs. Always troubleshoot according to the current symptom.
2. Spare parts can fail. Do not ignore the possibility of a failure just because the part has been replaced once.

WARNING

Turn power off before disconnecting or replacing any FRU.

1.2 Troubleshooting the LA100

The LA100 terminals have a series of self tests that are used to isolate failures to the field replaceable unit (Figure 1-1). The tests used are performed in the following order:

Test	Paragraph
Power Up Self Test	1.3
Printer Self Test	1.4
Loopback Test	1.5

After you adjust or replace an FRU, perform these the tests to verify proper terminal operation.

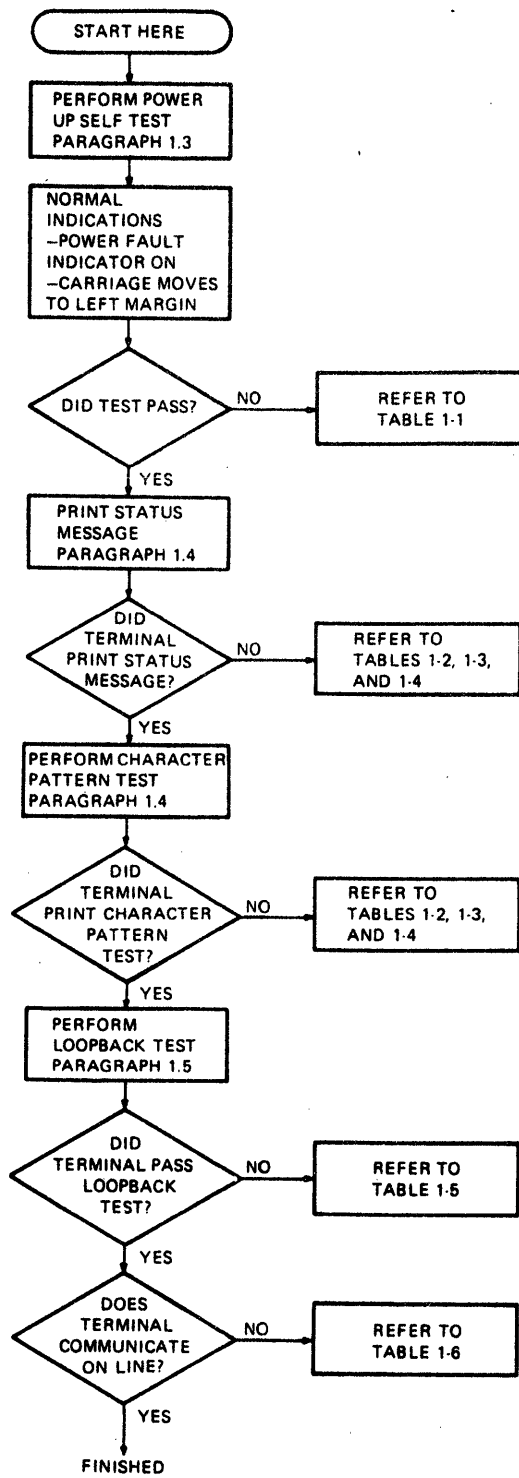

MA-8976

Figure 1-1 Troubleshooting Procedure

### 1.3 Power-Up Self Test

The LA100 performs a power-up self-test when the terminal power is turned on. A successful power up self test is indicated when the printhead moves to the left margin and the POWER/FAULT indicator is on. If the terminal fails to power up correctly refer to Table 1-1.

#### NOTE

The Letterwriter 100 printhead may move a short distance to the right after moving to the left margin if automatic last character view is selected and stored in the user permanent memory.

To perform the power-up self test, move the Power ON-OFF switch to the "ON 1" (up) position (Figure 1-2).

#### NOTE

If the terminal power is already on move the Power ON/OFF switch to the off position first.

### 1.4 Printer Self Tests

The printer self-tests provide a visual indication that the terminal is operating correctly. Four printing and one nonprinting self tests are available:

- Status message
- Character pattern
- Single character (Letterwriter 100 only)
- Horizontal registration
- Non-Printing

When troubleshooting the LA100, print the status message and perform at least the character pattern test to ensure the terminal can print correctly. The status message shows the terminal can print and gives you list of terminal feature selections. The character pattern test allows you to check print quality and observe other terminal functions. When performing these tests, terminal failures will fall into one of the following functional areas:

- |                                      |           |
|--------------------------------------|-----------|
| Carriage motion                      | Table 1-2 |
| Paper feeding                        | Table 1-3 |
| Print character quality              | Table 1-4 |
| (Not applicable to nonprinting test) |           |

**Table 1-1 Power Up Failures**

<b>DSR Indicator</b>	<b>POWER/FAULT Indicator</b>	<b>Probable Cause</b>	<b>Action</b>
Off	Off no carriage motion	Power Fuse (F1) Not plugged in No power at wall receptacle	Replace fuse Plug in Try a different receptacle if possible, check breaker, call electrician
		115/230 voltage selector switch	Make sure that the 115/230 voltage is set to the proper range
		Internal logic/ power cable	Check cable
		Power supply	Replace power supply
Off	Off carriage motion	Logic board board	Replace logic board
		Keyboard/Oper- ator control panel cable	Check keyboard/ operator control panel cable at J6 on logic board
		Keyboard/Oper- ator control panel assembly	Replace keyboard/ operator control panel assembly
1 Flash	1 Flash	Logic board	Replace logic board
1 Flash	1 Flash	ROM 1 defective or not present	Replace ROM
2 Flashes	2 Flashes	ROM 2 defective (may be cartridge or plug-in ROM)	Replace ROM
3 Flashes	3 Flashes	ROM 3 defective	Replace ROM
4 Flashes	4 Flashes	ROM 4 defective (may be cartridge or plug-in ROM)	Replace ROM

**Table 1-1 Power Up Failures (Cont)**

DSR Indicator	POWER/FAULT Indicator	Probable Cause	Action
5 Flashes	5 Flashes	ROM 5 defective	Replace ROM
6 Flashes	6 Flashes	1st microcode ROM defective	Replace logic board
7 Flashes	7 Flashes	2nd microcode ROM defective	Replace logic board
8 Flashes	8 Flashes	RAM defective	Replace logic board
9 Flashes	9 Flashes	Optional ROM defective	Replace logic board
On or Off No bell	Flashing	Cover open, or paper fault	Close cover, press CLEAR FAULT key
		Access cover switch	Replace switch
			<b>NOTE</b> The access cover interlock switch is a magnetic proximity type switch. Before replacing switch, check magnet in access cover.
		Logic board board	Replace logic board
On or Off Bell tones	Flashing	Head jam	Clear jam, press CLEAR FAULT/FAULT RESET key
		Servo motor encoder connectors	Check servo connectors at J1, J3 of the logic board, and connectors on servo motor encoder assembly

**Table 1-1 Power Up Failures (Cont)**

DSR Indicator	POWER/FAULT Indicator	Probable Cause	Action
		Servo motor encoder assembly	Replace servo motor encoder assembly
		Logic board	Replace logic board
On	On	Terminal is receiving Data Set Ready DSR signal	Terminal passes power-up self test
Off	On	Terminal is not receiving Data Set Ready DSR signal	Terminal passes power-up self test

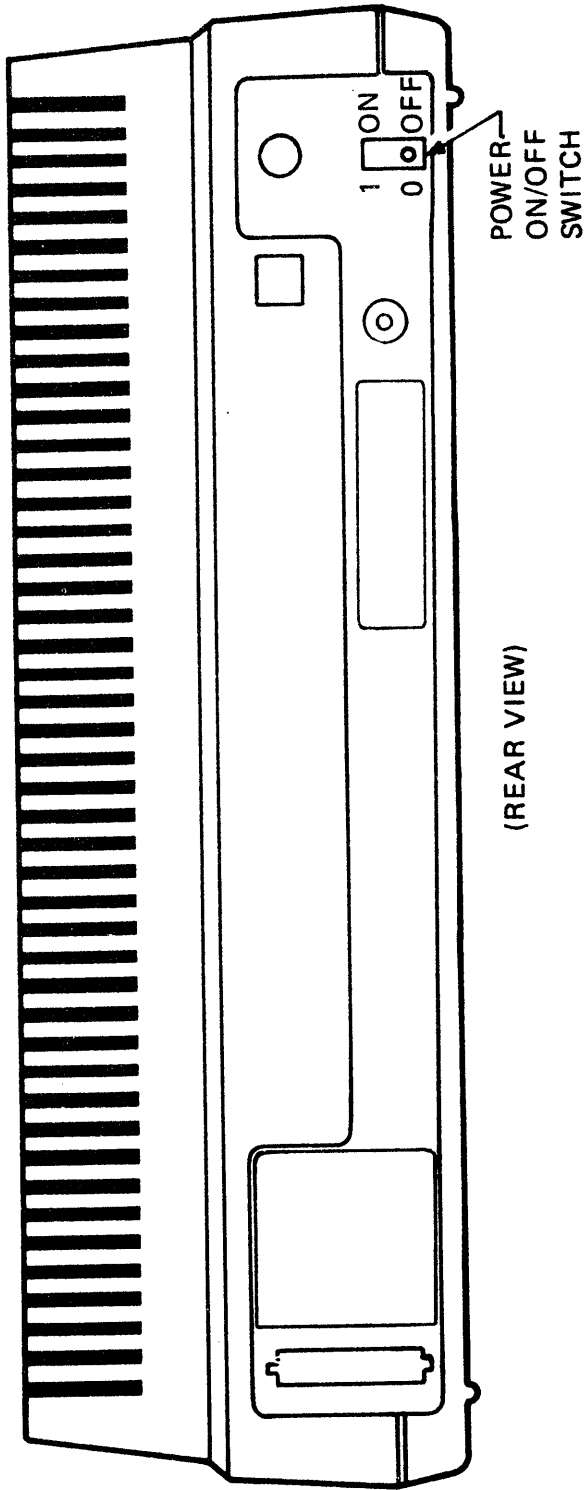

(REAR VIEW)

MA-7228

Figure 1-2 Power ON/OFF Switch

**Table 1-2 Carriage Motion Failures**

Symptom	Probable Cause	Remedy
No printing, carriage does not move	Paper out switch	If you are not feeding paper from the bottom of the terminal, disable paper out detection
	Keyboard/Operator control panel cable	Check keyboard/operator control panel cable at J6 on logic board
	Keyboard/Operator control panel assembly	Replace keyboard/operator control panel assembly
	Logic board	Replace logic board
	Power supply	Replace power supply
No printing, carriage moves	Printhead adjustment	Adjust printhead assembly
	Ribbon cartridge	Replace ribbon cartridge
	Printhead cable	Check printhead connector at printhead and J5 on the logic board
	Logic board	Replace logic board
	Printhead assembly	Replace printhead assembly
No printing, carriage slams to left or right	Logic board	Replace logic board
	Servo motor encoder assembly	Replace encoder assembly
	Power supply	Replace power supply
Printhead prints, but carriage does not move	Logic board	Replace logic board
	Pulley/tension gear	Replace pulley/tension assembly
	Timing belt broken or slipped out of carriage	Check and replace timing belt if necessary
	Servo motor encoder assembly	Replace encoder assembly



**Table 1-3 Paper Feed Failures**

Symptom	Probable Cause	Remedy
No line feeds	Platen assembly	Check that gears are properly engaged, also platen clutch/gear assembly
	Platen assembly dirty	Clean platen assembly
	Stepper motor connector	Check stepper motor connector at J2 on the logic board
	Logic board	Replace logic board
	Keyboard/Operator control panel cable	Check keyboard/operator control panel cable at J6 on logic board
	Keyboard/Operator control panel assembly	Replace keyboard/operator control panel assembly
	Stepper motor	Replace motor
	Antibacklash gear	Replace gear
Improper line feeds (inconsistent vertical motion)	Paper path obstructed	Clean paper path
	Platen assembly	Check that gears are properly engaged, also platen clutch/gear assembly
	Paper guide	Check that paper guide is properly seated
	Stepper motor connector	Check stepper motor connector at J2 on the logic board
	Logic board	Replace logic board
	Stepper motor	Replace stepper motor
Continual line feeds	Keyboard/Operator control panel assembly	Replace keyboard/operator control panel assembly

**Table 1-3 Paper Feed Failures (Cont)**

Symptom	Probable Cause	Remedy
	Logic board	Replace logic board
	Stepper motor	Replace stepper motor
Print line slanted up or down -- friction feed applications	Friction feed	Adjust friction feed or replace
	Cams and lever assembly	Install new cam and lever assembly
	Paper path obstructed	Clear paper path
Print line slanted up or down -- tractor feed applications	Tractor sprockets	Check that sprockets are in line on both tractors
	Paper routing	Check that paper routing is correct
	Paper path obstructed	Clear paper path
Flat descenders on characters (see Figure 1-3 for example)	Printhead cable	Check printhead cable
	Printhead lift	Replace printhead lift/ carriage assembly

LA100 V1.0 RO  
0.4K Buffer  
DPSs: 005...009.....

\*Printer Settings :

Pitch Mode:All Pitches  
G0 Character set:United States  
G1 Character set:United States  
G2 Character set:United States  
G3 Character set:United States  
Form Length:264  
Horiz pitch (cpi):10  
End of line control:wrap mode  
Vert pitch (lpi):6  
NewLine request char.:none

\*Communication Settings :

Auto-answerback:Disabled  
Disconnect on EOT:Disabled  
Paper fault processing:XOFF (if enabled)  
Parity:7/M  
Receiver error:Print error block  
Speed(bps):4800  
Auto XON/XOFF:Enabled  
Modem Control:No Modem Control-Restraint Mode

MA-9821

Figure 1-3 Flat Descenders Example

Table 1-4 Print Quality Failures

Symptom	Probable Cause	Remedy
Characters missing	Logic board	Replace logic board
Missing dots on any printable character (always same row missing)	Ribbon cartridge	Replace ribbon cartridge
	Printhead assembly	Replace printhead assembly
	Printhead cable	Check printhead connector at J5 on the logic board
	Logic board	Replace logic board
Missing dots only on some characters	Logic board	Replace logic board
Prints incorrect characters (character format O.K.)	Incorrect character set selected	Check character set selected in SET-UP
	Logic board	Replace logic board
Print density drops off to no impression	Printhead adjustment	Adjust printhead assembly
	Ribbon cartridge	Replace ribbon cartridge
	Platen assembly	Platen not seated properly; reseal
	Ribbon drive cables	Check cables, replace if necessary
	Ribbon drive pulley	Replace carriage assembly
Print density varies randomly across page	Ribbon cartridge	Replace ribbon cartridge
	Ribbon drive cables	Check cables and replace if necessary
	Carriage assembly	Replace carriage assembly
Prints light-to-dark or dark-to-light across face	Printhead not parallel to platen	Rotate carriage shafts. Replace shafts.

**Table 1-4 Print Quality Failures (Cont)**

Symptom	Probable Cause	Remedy
First few characters in line print light	Ribbon cartridge	Replace cartridge
	Carriage bearings dirty - shafts dirty	Clean bearings and shafts. Relubricate
	Ribbon drive cables	Replace drive cables
	Ribbon clutch	Replace carriage
	Main drive belt	Replace drive belt
	Encoder belt	Replace encoder belt
Left or right margin excessively wavy	Main drive belt	Replace main drive belt
	Encoder belt	Replace encoder belt
	Carriage bearings dirty - shafts dirty	Clean bearings and shafts. Relubricate
	Ribbon cartridge	Replace cartridge
	Servo motor Encoder assembly	Replace servo motor encoder assembly
	Logic board	Replace logic board

**Table 1-5 Loopback Test Failures**

<b>Symptom</b>	<b>Probable Cause</b>	<b>Remedy</b>
<b>Data error printout</b>	Logic board	Replace logic board
	Power supply	Replace power supply
	Power cable to logic board	Replace power cable
	EIA cable assembly (internal)	Replace cable assembly
	20 mA interface	
	20 mA cables	
	Loopback connector	Replace loopback connector
<b>Control line error</b>	Logic board	Replace logic board
	EIA cable assembly (internal)	Replace cable assembly
	Loopback connector	Replace loopback connector
	20 mA interface	Remove 20 mA interface

**Table 1-6 Communication Failures**

<b>Symptom</b>	<b>Probable Cause</b>	<b>Remedy</b>
No key codes transmitted (EIA operation). Local operation normal (Letterwriter 100 only)	LINE/LOC switch	Check for proper switch selection
	EIA cable	Check EIA connector J7; if necessary replace cable
No key codes generated (local or on line)	Logic board	Replace logic board
	Power supply	Replace power supply
	Power cable to logic board	Replace power cable
	Keyboard cable	Check cable
	Keyboard assembly	Replace Keyboard assembly
One (or more) key codes not generated	Keyboard assembly	Replace keyboard assembly
	Logic board	Replace logic board
No characters printed	Incorrect communication feature set up	Print status message. Verify that correct features are selected.
	Modem unplugged or set up incorrectly selected.	Plug modem in. Verify that correct features are Refer to modem user guide.
Garbled characters printed	Incorrect communication feature set up	Print status message. Verify that correct features are selected.
Prints double characters	Double local echos	Disable local echo
	Keyboard assembly	Replace keyboard assembly
	Logic board	Replace logic board

**Table 1-6 Communication Failures (Cont)**

<b>Symptom</b>	<b>Probable Cause</b>	<b>Remedy</b>
No answerback message	Message not entered	Enter answerback message
	Logic board	Replace logic board
No bell tone	Keyboard/Operator control panel cable	Check keyboard/operator panel cable at J6 on the logic board
	Keyboard/Operator control panel assembly	Replace keyboard/operator control panel assembly
	Logic board	Replace logic board



#### 1.4.1 Status Message

The status message (shown in Figure 1-4) is a feature that is useful when troubleshooting the LA100 terminal. It provides the service technician with the following information:

shows that the terminal can move the carriage, print characters, and move paper

allows the technician to check printed character quality

shows what features are set in operating memory

shows the current microcode revision

shows what DPSs are present

Before servicing any terminal, always try to print out the status message. This helps you to troubleshoot the terminal. Also, after you replace an FRU, check the status message to ensure that the features stored in operating memory are correct.

#### 1.4.2 Character Pattern Test

The character pattern test (shown in Figure 1-5) causes the terminal to continuously print 94 characters within the currently selected margins. Performing this test shows that the terminal can move the carriage, print characters, and move paper.

#### 1.4.3 Single Character Test (Letterwriter 100 only)

The single character test (shown using the Letter F in Figure 1-5) is used to test the terminal while printing a single character. The selected character is printed continuously until you stop the test. Performing this test shows that the terminal can move the carriage, print characters, and move paper.

#### 1.4.4 Horizontal Registration Test

The horizontal registration test (shown in Figure 1-5) is also used to show that the terminal can move the carriage, print characters, and move paper. During the horizontal registration test the terminal prints the symbol shown Figure 1-5 in six passes per line.

#### NOTE

The only terminal prints during 4 of the 6 passes.

#### 1.4.5 Non-Printing Test

The non-printing test is performed when you do not need to test character printing. During the non-printing test, the terminal moves the carriage from the left margin to the right margin, back to the left margin, and then advances the paper one line. The test is repeated continuously until you end it.

\$%&'()\*+,-./0123456789:;<=>?@ABCDEFGHIJKLMN0PQRSTUVWXYZ[\]^\_`abcdef  
Z&'()\*+,-./0123456789:;<=>?@ABCDEFGHIJKLMN0PQRSTUVWXYZ[\]^\_`abcdef  
&'()\*+,-./0123456789:;<=>?@ABCDEFGHIJKLMN0PQRSTUVWXYZ[\]^\_`abcdefg  
'()\*+,-./0123456789:;<=>?@ABCDEFGHIJKLMN0PQRSTUVWXYZ[\]^\_`abcdefgh  
()\*+,-./0123456789:;<=>?@ABCDEFGHIJKLMN0PQRSTUVWXYZ[\]^\_`abcdefghi

FF  
FF  
FF  
FF  
FF

\*\*\*\*\*  
\*\*\*\*\*  
\*\*\*\*\*  
\*\*\*\*\*  
\*\*\*\*\*

MA-8324

Figure 1-4 Sample Status Message

\$%&'()\*+,-./0123456789:;<=>?@ABCDEFGHIJKLMNPOQRSTUVWXYZ[\]^\_`abcde  
%&'()\*+,-./0123456789:;<=>?@ABCDEFGHIJKLMNPOQRSTUVWXYZ[\]^\_`abcdef  
&'()\*+,-./0123456789:;<=>?@ABCDEFGHIJKLMNPOQRSTUVWXYZ[\]^\_`abcdefg  
'()\*+,-./0123456789:;<=>?@ABCDEFGHIJKLMNPOQRSTUVWXYZ[\]^\_`abcdefgh  
()\*+,-./0123456789:;<=>?@ABCDEFGHIJKLMNPOQRSTUVWXYZ[\]^\_`abcdefghi

FF  
FF  
FF  
FF  
FF

\*\*\*\*\*  
\*\*\*\*\*  
\*\*\*\*\*  
\*\*\*\*\*  
\*\*\*\*\*

MA-8324

Figure 1-5 Self-Test Examples

#### 1.4.6 Performing the Printer Tests

The following paragraphs describe the procedures use to perform the printer tests.

##### 1.4.6.1 Performing the Letterprinter 100 Printer Tests

Perform the following procedure to perform the Letterprinter 100 printer tests.

1. Ensure that the terminal power is on.
2. Press and lock the ON LINE/OFF key in the OFF (down) position.
3. Press and lock the SELF-TEST key in the down position. The status message is printed.

#### NOTE

If the SELF-TEST key is already in the down position, release the SELF-TEST key and then relock it in the down position.

4. Press the FORM FEED key. The character pattern test is printed.
5. Press the FORM FEED key again. The horizontal registration test is printed.
6. Press the FORM FEED key again. The non-printing test is performed.

#### NOTES

The terminal repeats the printer tests in the same order each time the FORM FEED key is pressed.

Release the SELF-TEST key to stop any test.

##### 1.4.6.2 Performing the Letterwriter 100 Printer Tests

Perform the following procedures to use the Letterwriter 100 printer tests.

1. While pressing the CTRL key, press the SET-UP key. The SET-UP indicator flashes.
2. Press the 8 key and then press the RETURN key to print the status message.
3. Press the T key and then press the RETURN key to print the character pattern self-test.
4. Press the T key and then press any character key (except "\", "|", "?", and spacebar) to print the single character test.

5. Press the T key and then release it. While pressing the SHIFT key, press the \ key to print the horizontal registration test.
6. Press the T key and then press the spacebar to perform the non-printing test.
7. Press the SET-UP key to end the test and exit SET-UP. The SET-UP indicator stops flashing.

NOTE

To end the test and remain in SET-UP, press any character key (or space bar) on the keyboard except the SET-UP key.

### 1.5 Loopback Test

The loopback test is used to check the terminal's communication control signals. It is also used to check the terminal's ability to transmit and receive characters. During the loopback test, the transmit and receive lines are connected to each other using a loopback connector (Figure 1-6).

The terminal then transmits characters on the transmit lines and receives the characters on its receive. The terminal checks the control signals as well as the terminal baud rate and parity. The terminal compares the transmitted data with the received data and prints two of the following messages (one for the control lines, the other for the data path):

```
CONTROL LINE OK
CONTROL LINE FAILED (20mA ?, JUMPERS ?)
DATA PATH OK
DATA PATH FAILED
DATA PATH STOPPED
```

NOTE

The terminal prints the CONTROL LINE FAILED message when the 20 mA loop interface option is installed or the EIA circuit jumpers are removed. In both cases the control lines are not used.

#### 1.5.1 Performing the Loopback Test

The following paragraphs describe the procedures used to perform the loopback tests.

CONNECTORS

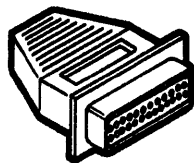

FROM PIN	TO PIN	TO PIN
2	3	—
4	5	—
20	6	—
19	22	—
12	23	8

EIA

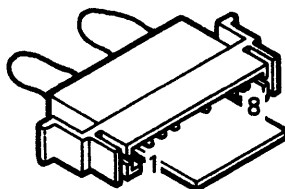

FROM PIN	TO PIN
2	3
5	7

20 MA

MA-7266A

Figure 1-6 Loopback Connectors

### 1.5.1.1 Performing the Letterprinter 100 Loopback Test

Perform the following procedure to start the Letterprinter 100 loopback test.

1. If the 20 mA interface option is used, set the TRANS/REC switches; one to NORMAL and one to ACTIVE (refer to the Options chapter to gain access to the switches).
2. Unplug the communication cable from the back of the terminal (Figure 1-7).
3. Connect the loopback connector to the terminal interface connector (EIA or 20 mA).
4. Press and lock the ON LINE/OFF key in the OFF (down) position.
5. Press and lock the SELF-TEST key in the down position. The status message is printed.

#### NOTE

If the SELF-TEST key is in the down position, release the SELF-TEST key and then relock it in the down position.

5. Press the TOF key to start the Loopback test. When complete, the terminal prints a pass or fail message.
6. If the 20 mA interface option is used, return the TRANS/REC switches to their original positions (refer to the Options chapter to gain access to the switches).

### 1.5.1.2 Performing the Letterwriter 100 Loopback Test (Test 1)

Perform the following procedure to start the Letterwriter 100 loopback test 1.

1. Unplug the communication cable from the back of the terminal (Figure 1-7).
2. Install the loopback connector.
3. Ensure that the terminal is on line (LINE indicator on).
4. While pressing the CTRL key, press the SET-UP key. The SET-UP indicator flashes.
5. Press T and then press \ to start loopback test 1.
6. Press the SET-UP key to end the test and exit SET-UP. The SET-UP indicator stops flashing.

#### NOTE

To end the test and remain in SET-UP, press any character key (or space bar) on the keyboard except the SET-UP key.

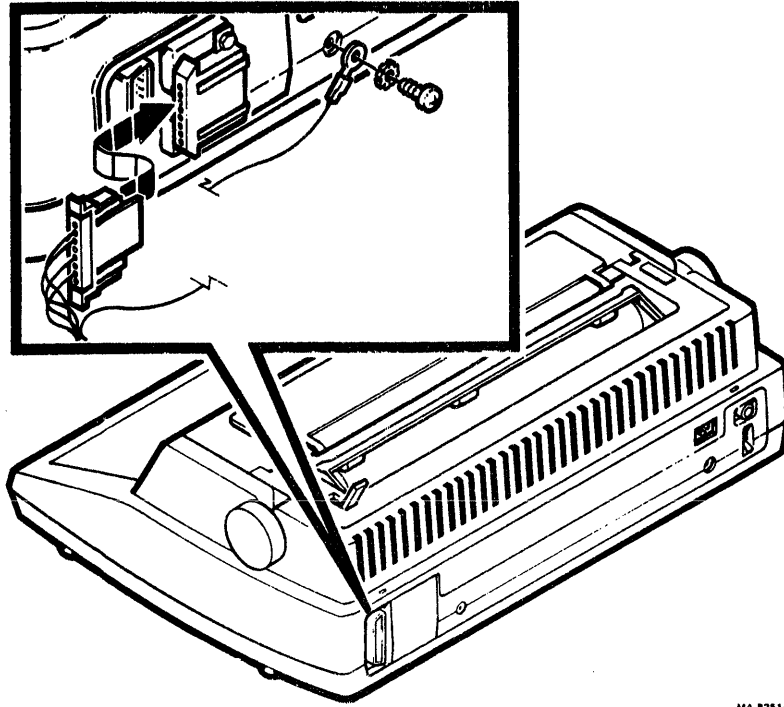

MA-8251A

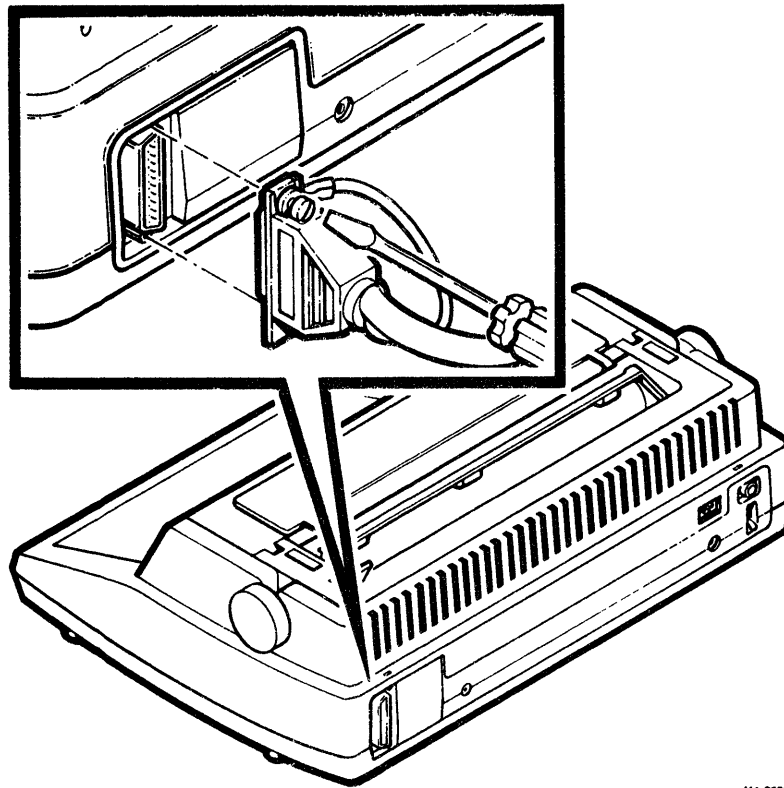

MA-8250A

Figure 1-7 Removing Communication Cable



### 1.5.2.2 Performing the Letterwriter 100 Loopback Test (Test 2)

Perform the following procedure to start the Letterwriter 100 loopback test 2.

1. Unplug the communication cable from the back of the terminal (Figure 1-7).
2. Install the loopback connector.
3. Ensure that the terminal is on line (LINE indicator on).
4. While pressing the CTRL key, press the SET-UP key. The SET-UP indicator flashes.
5. Press T and then, while pressing SHIFT, press \ to start loopback test 2.
6. Press the SET-UP key to end the test and exit SET-UP. The SET-UP indicator stops flashing.

#### NOTE

To end the test and remain in SET-UP, press any character key (or space bar) on the keyboard except the SET-UP key.



2  
FRU REMOVAL AND REPLACEMENT

## 2.1 GENERAL

This chapter describes Field Replaceable Unit (FRU) removal, replacement, and adjustment for all models of the LA100 terminal.

Figure 2-1 illustrates all the removal procedures described in this chapter and the sequence in which these procedures are performed. As an example, to remove the stepper motor the printer housing cover and paper drive cluster gear must first be removed.

## 2.2 PRINthead ASSEMBLY

The following procedure describes the removal and installation of the printhead assembly.

1. Lift the access cover (Figure 2-2).
2. Remove the ribbon cartridge (Figure 2-2).
3. Push the printhead release lever toward the back of the terminal (Figure 2-3).
4. Lift the printhead up until you can grasp the printhead cable connector (Figure 2-3).
5. Disconnect the printhead from the printhead cable.
6. Remove the printhead.
7. To install a new printhead, perform steps 1-6 in reverse order.

**NOTE** When reinstalling the print head make sure the pins on the printhead are properly matched to the print head cable.

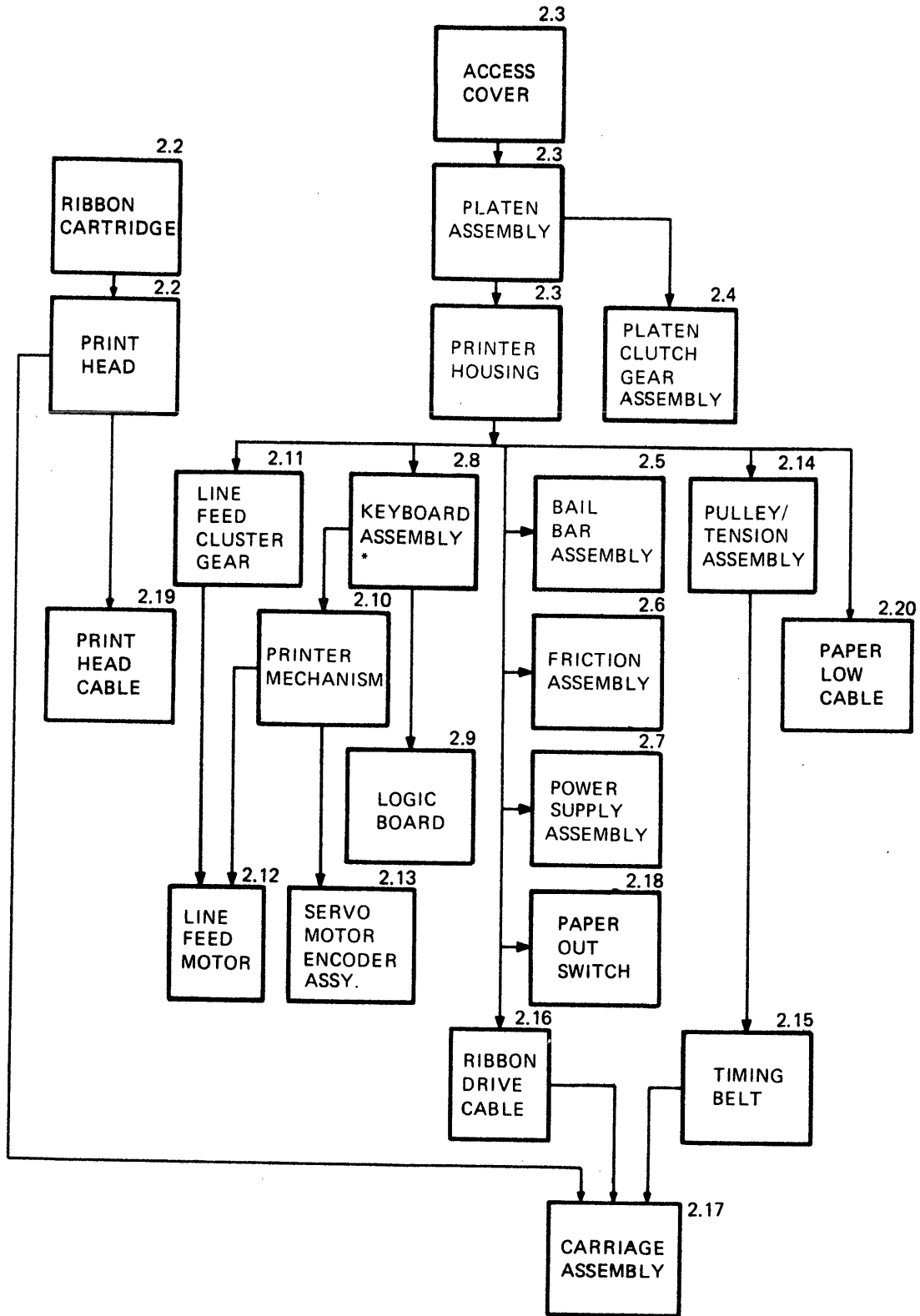

MA-2862B

Figure 2-1 Assembly Removal Sequence

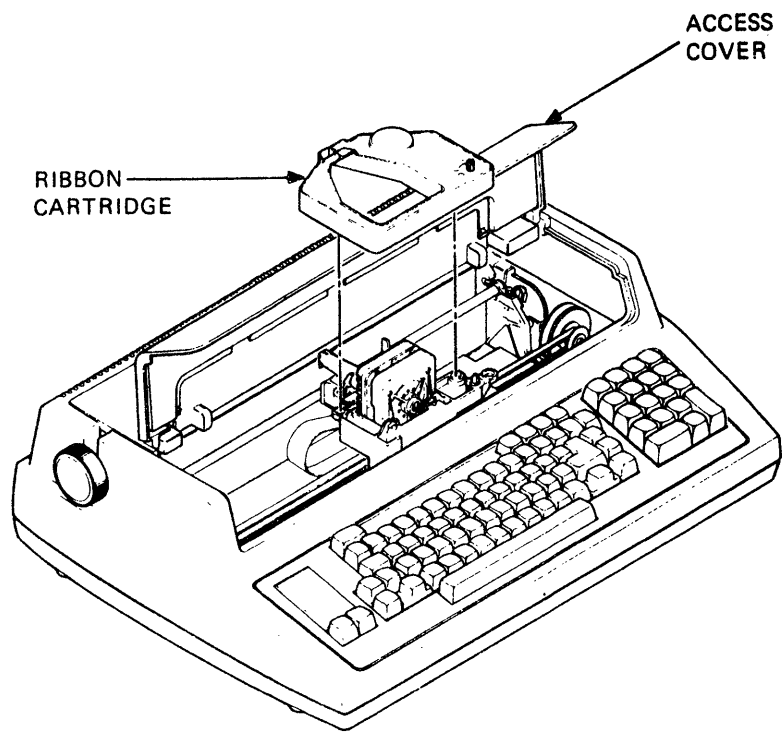

MA7420C

Figure 2-2 Removing the Ribbon Cartridge

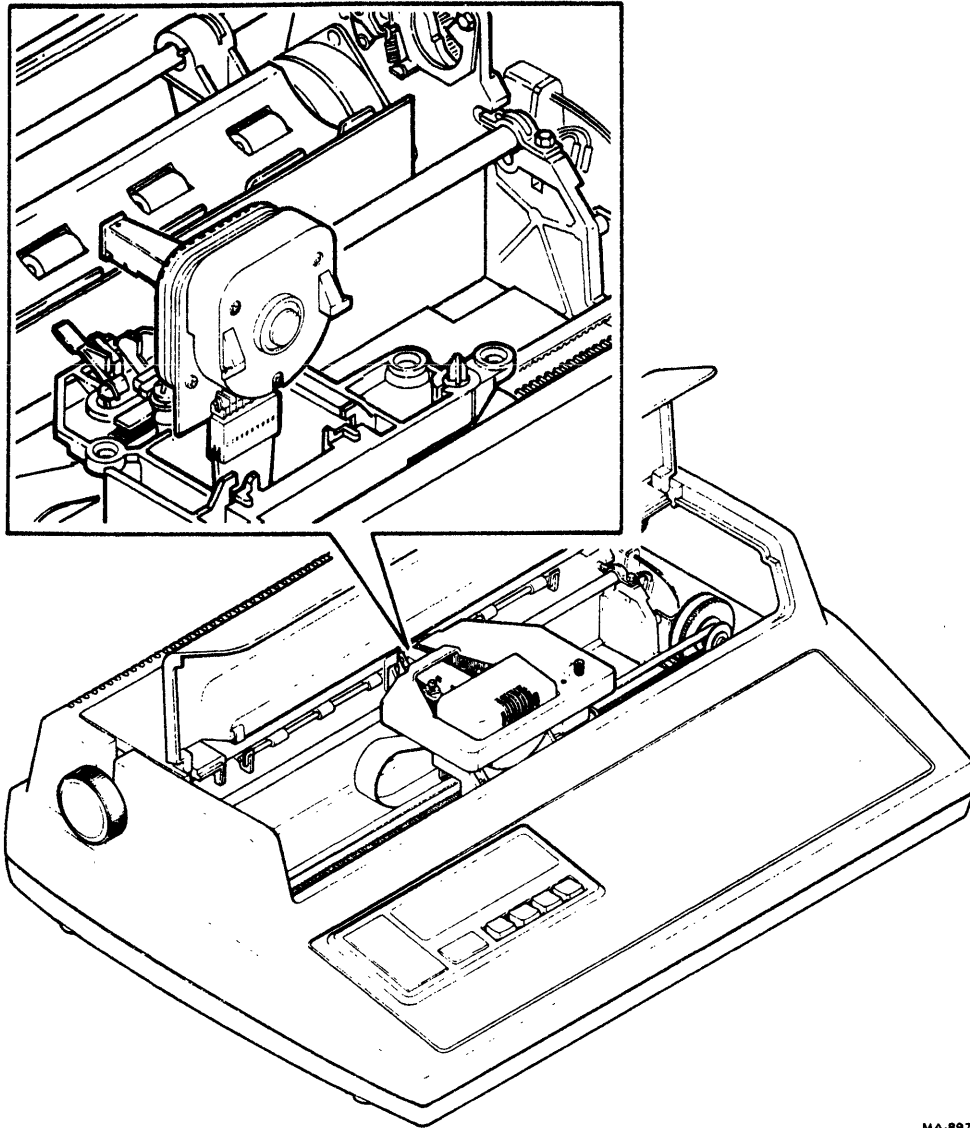

MA-8972

Figure 2-3 Removing the Print Head

## 2.3 PRINTER HOUSING COVER

The following procedure describes the removal and installation of the printer housing cover.

### 2.3.1 Printer Housing Cover Removal

1. Turn the power ON/OFF switch off.
2. Unplug the ac power cord from the wall receptacle and then the printer.
3. Remove the paper from the printer.
4. If the printer is attached to a printer stand, remove the terminal from the stand. Refer to the Options chapter for more detail.
5. Remove the roll paper holder or tractor options if installed. Refer to the Options chapter for more detail.
6. Remove the access cover by opening it and pressing the two access cover retainer clips at the same time (Figure 2-4). Lift the access cover straight up.
7. Remove the ribbon cartridge.
8. Lift the bail bar to gain access to the platen. Remove the platen by pressing the two platen release levers at the same time (Figure 2-5). Lift the platen straight up. Lower the bail bar to its original position.
9. Using a scribe, release the four snap fasteners that secure the printer housing cover to the base assembly (Figure 2-6).
10. Remove the printer housing cover by lifting it straight up.

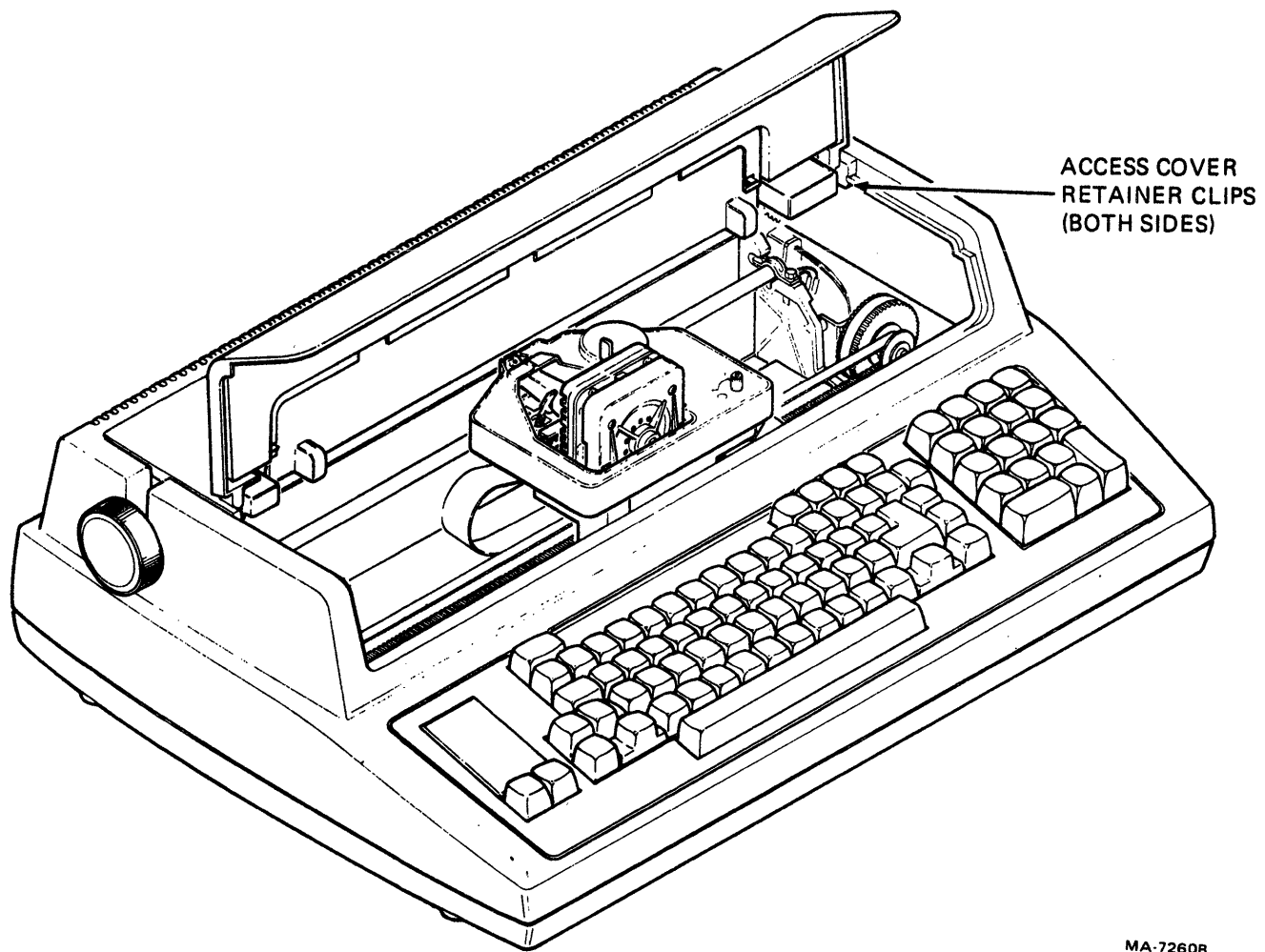

MA-7260B

Figure 2-4 Access Cover Removal



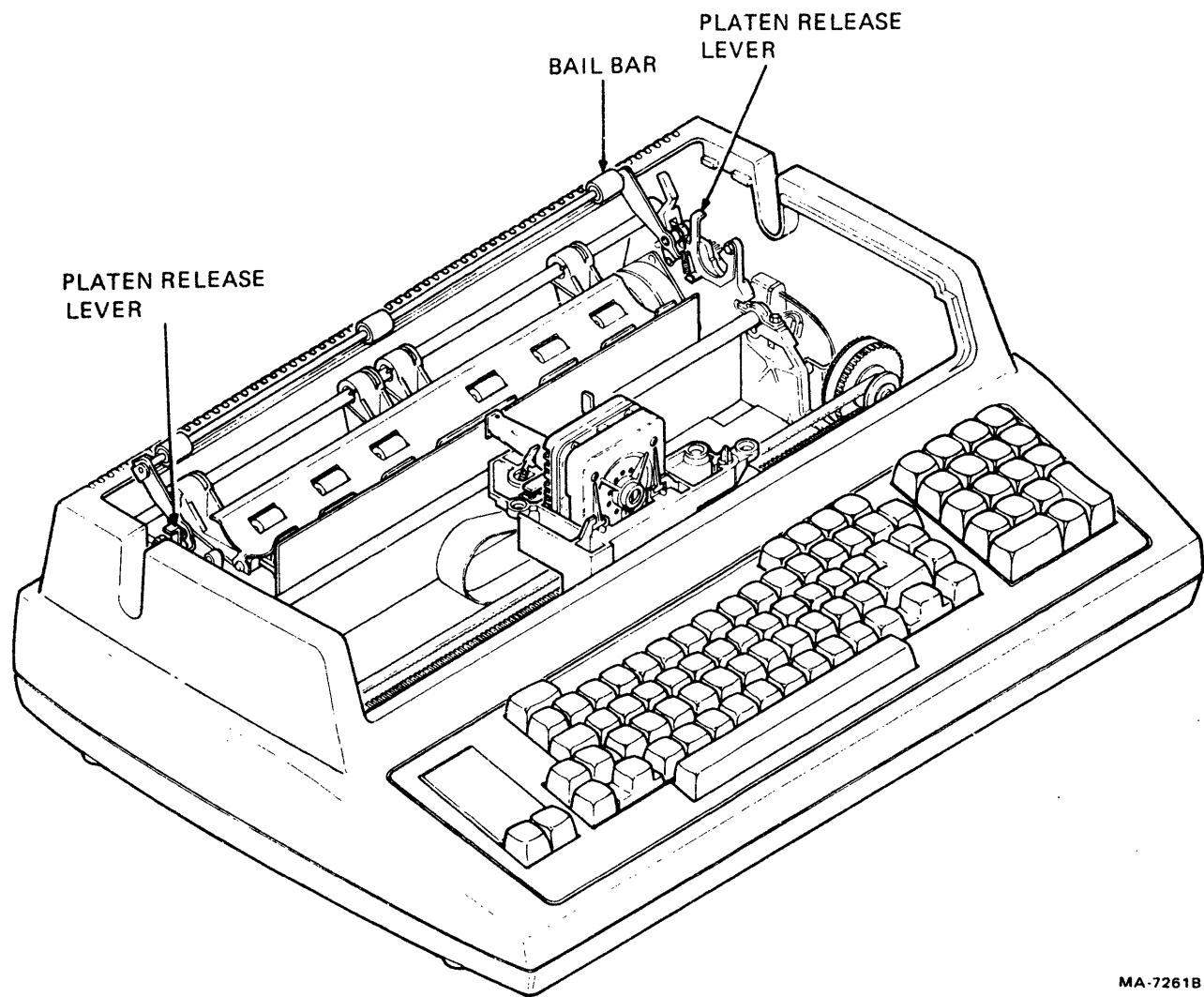

MA-7261B

Figure 2-5 Platen Removal

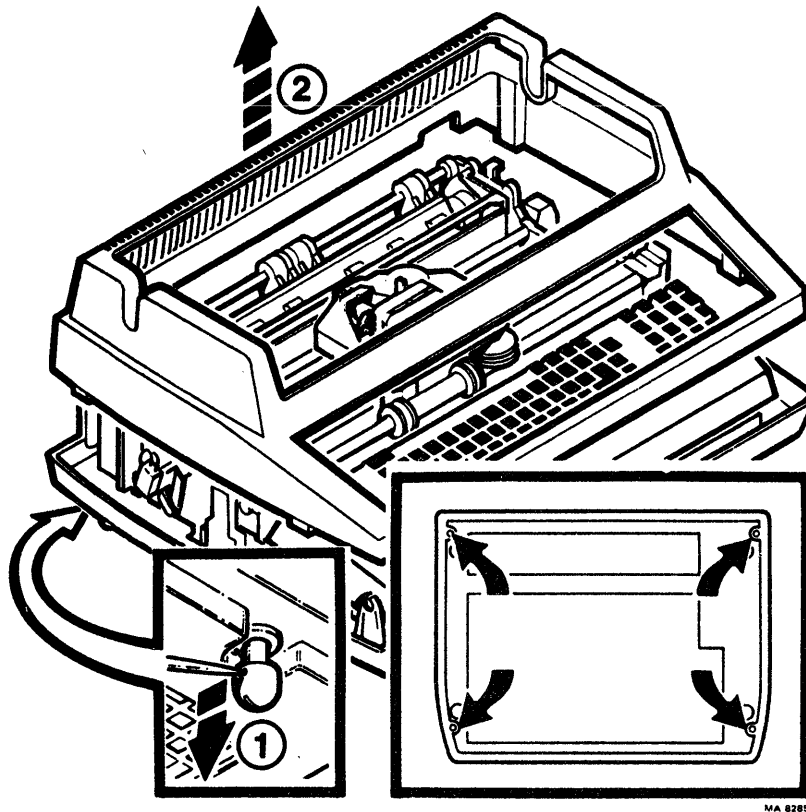

Figure 2-6 Printer Housing Cover Removal

### 2.3.2 Printer Housing Installation

1. Make sure that the tabs on the rear insert line up with the slots in the printer housing cover (Figure 2-7).
2. Place the printer housing cover on the base assembly.
3. Press the four snap fasteners closed to secure the cover to the base assembly.
4. Reinstall the platen by lifting the bail bar and pressing the platen into place. Rotate the paper advance knob to check that the gears are properly engaged. Lower the bail bar to its original position.
5. Reinstall the ribbon cartridge.
6. Slide the back edge of the access cover under the lip in the printer housing cover and press the access cover into place.
7. Reinstall the roll paper holder or tractor options if needed. Refer to the Options Chapter for more detail.
8. If the printer stand is used, attach the terminal to the stand. Refer to the Options chapter for more detail. Reinstall the paper.
9. Plug the ac power cord into the back of the printer. Then plug the power cord into a nonswitched, three-prong, grounded wall receptacle.
10. Turn the power ON/OFF switch on.

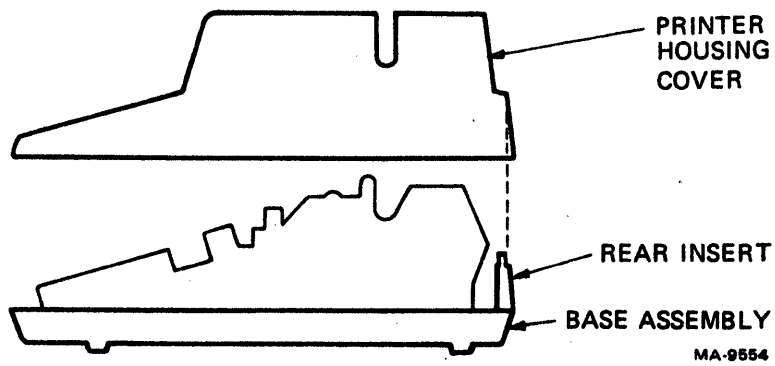

Figure 2-7 Printer Housing -- Rear Insert Alignment

## 2.4 PLATEN CLUTCH/GEAR ASSEMBLY

The following procedure describes the removal and installation of the platen clutch/gear assembly.

### 2.4.1 Platen Clutch/Gear Assembly Removal

1. Turn the power ON/OFF switch off.
2. Unplug the ac power cord from the wall receptacle.
3. Remove the paper and tractor option if installed.
4. Remove the access cover by opening it and pressing the two access cover retainer clips at the same time (Figure 2-4). Lift the access cover straight up.
5. Lift the bail bar to gain access to the platen. Remove the platen by pressing the two platen release levers at the same time (Figure 2-5). Lift the platen straight up. Lower the bail bar to its original position.

#### CAUTION

Do not use too much pressure to release the tab on the platen knob as you may break the tab off.

All platen assemblies have a compression ring which secures the tab (Figure 2-8). Before lifting the tab, slide this ring toward the knob.

6. Using a small blade screwdriver, lift the tab on the end of the platen knob enough to release the knob from the platen shaft (Figure 2-8).
7. Remove the platen clutch/gear assembly.

### 2.4.2 Platen Clutch/Gear Assembly Installation

1. Slide the new assembly onto the shaft. Make sure the tabs on the gear engage the slots in the platen assembly (Figure 2-8).

#### NOTE

If it becomes necessary to clean the platen, use a damp cloth only.

2. Slide the platen knob onto the shaft. The knob is keyed and will only fit one way. Slide the ring back over the tab if the ring is included.

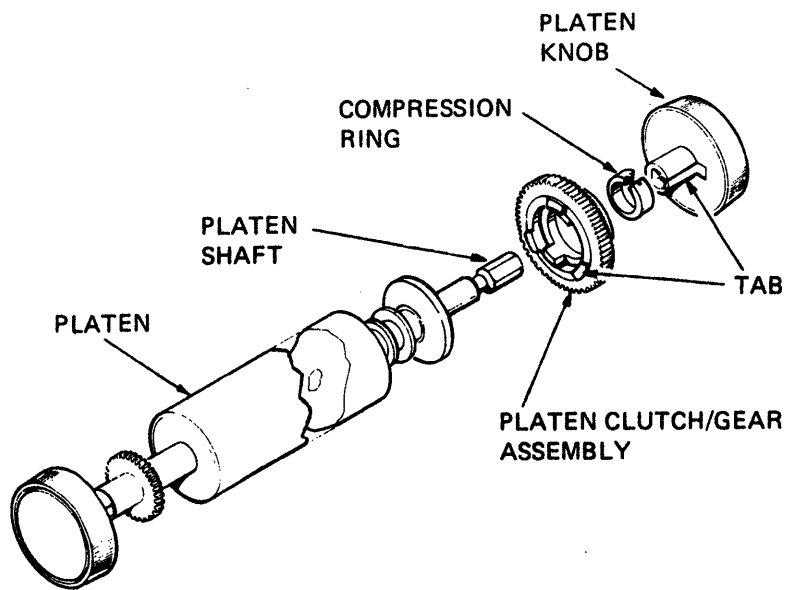

MA-9553

Figure 2-8 Platen Clutch/Gear Assembly Removal

3. Reinstall the platen by lifting the bail bar and pressing the platen into place. Rotate the paper advance knob to check that the gears are properly engaged. Lower the bail bar to its original position.
4. Slide the rear edge of the access cover under the lip in the printer housing and press the access cover into place.
5. Reinstall the paper and tractor option if installed.
6. Plug the ac power cord into a nonswitched, three-prong, grounded wall receptacle.

#### 2.5 BAIL BAR ASSEMBLY

The following procedure describes the removal and installation of the bail bar assembly.

1. Perform the printer housing cover removal procedure (Paragraph 2.3).
2. Using needlenose pliers, remove one end of the torsion spring from each end of the bail bar (Figure 2-9).
3. Using needlenose pliers, remove the bail bar retainer "C" clip from each end of the bail bar (Figure 2-9).
4. Press both ends of the bail bar in and lift straight up (Figure 2-9).
5. To install a new bail bar assembly, perform steps 1-4 in reverse order.

#### 2.6 FRICTION ASSEMBLY

The following procedure describes the removal and installation of the friction assembly.

1. Perform the printer housing cover removal procedure (Paragraph 2.3).
2. Lift the bail bar to gain access to the paper guide. Lift the paper guide straight out (Figure 2-10).
3. Remove the torsion spring that secures the paper release lever to the bail bar assembly (Figure 2-10).
4. Remove the (10-32) nut that secures the paper release lever to the right side plate (Figure 2-10).
5. While holding the friction assembly down, slide the stud out of the right side plate and lift the paper release lever straight up.

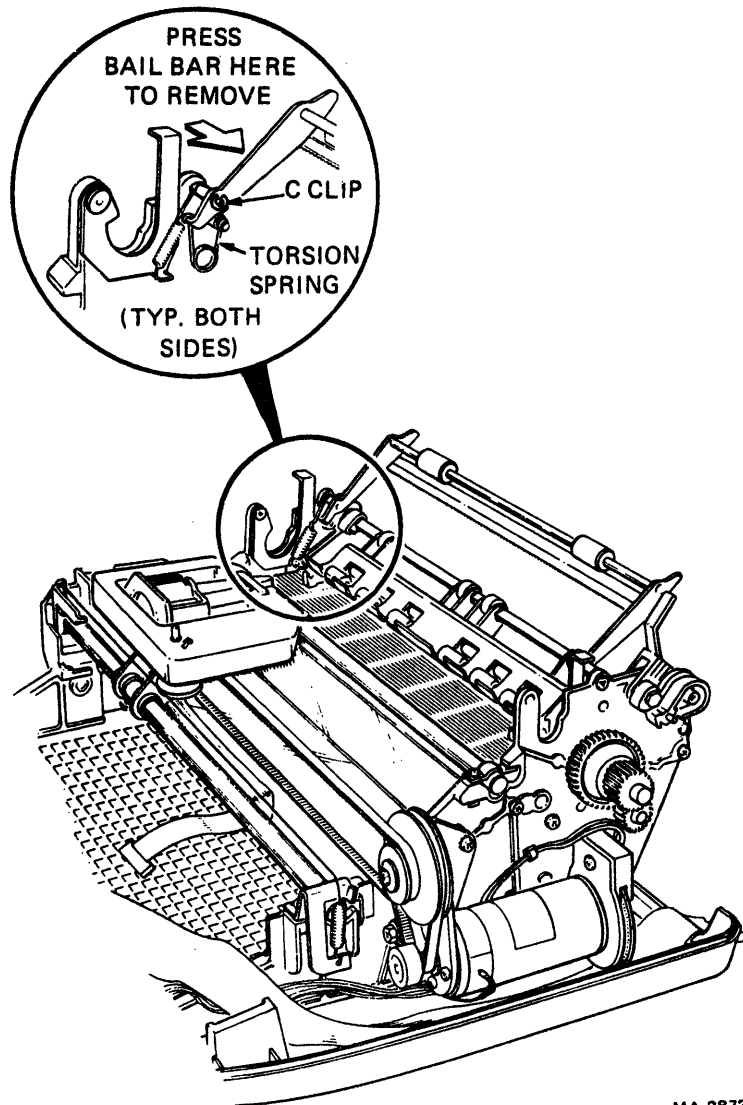

MA-2873D

Figure 2-9 Bail Bar Assembly Removal



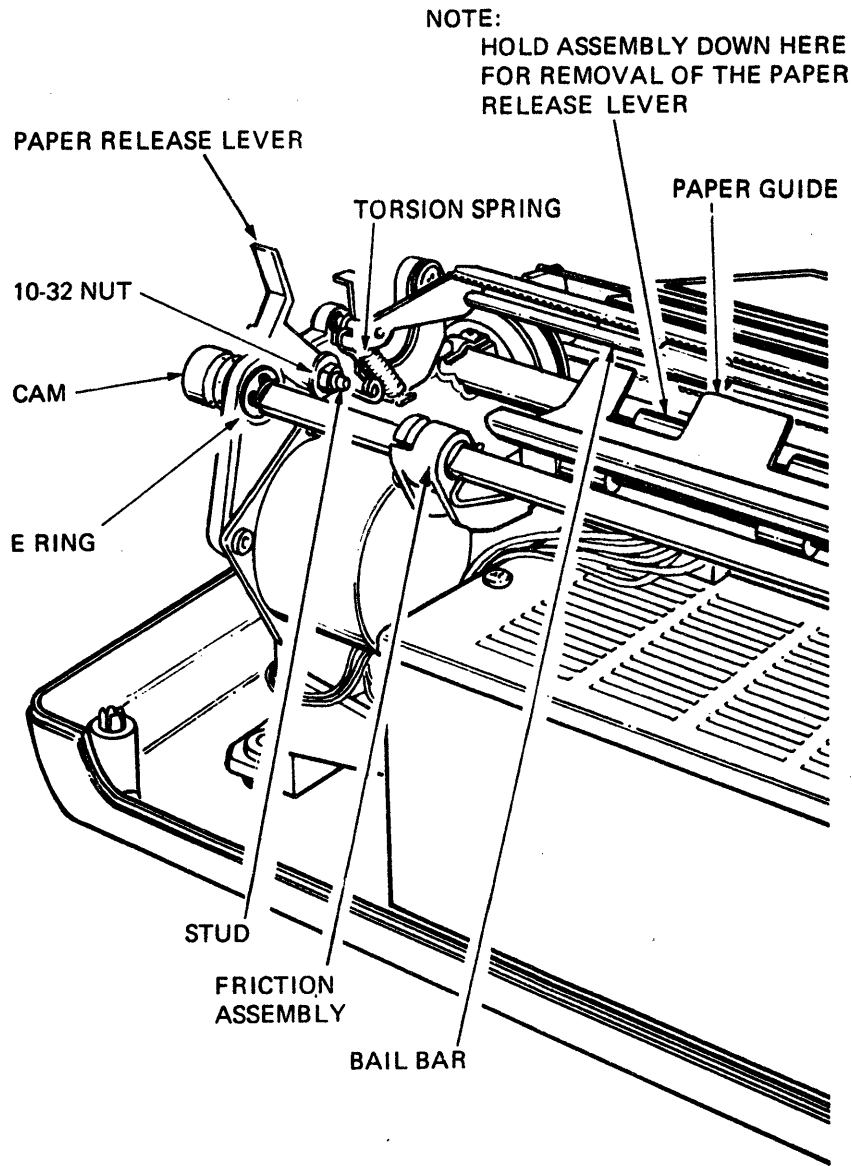

MA-2836A

Figure 2-10 Friction Assembly Removal

6. With a slotted screwdriver, remove the E-ring that secures the friction assembly end cap to the right side plate (Figure 2-10).

**NOTE**

When reinstalling the friction assembly make sure that the spring is properly seated in the side plate.

7. Pull the friction assembly towards the right side plate until it is free from the left side plate.
9. To install a new friction assembly, perform steps 1--7 in reverse order.

## **2.7 POWER SUPPLY ASSEMBLY**

The following procedure describes the removal and installation of the power supply assembly.

1. Perform the printer housing cover removal procedure (Paragraph 2.3).
2. Remove the rear insert (Figure 2-7).
3. Loosen the two (8-32) hex-head screws that secure the power supply to the left side as viewed from the rear of the terminal (Figure 2-11).
4. Remove the two (8-32) hex-head screws that secure the power supply to the right side as viewed from the rear (Figure 2-11).
5. Remove the logic/power cable from J6 on the power supply (Figure 2-11).
6. Carefully slide power supply from the printer mechanism.
7. To install the new power supply, perform steps 1--6 in reverse order.

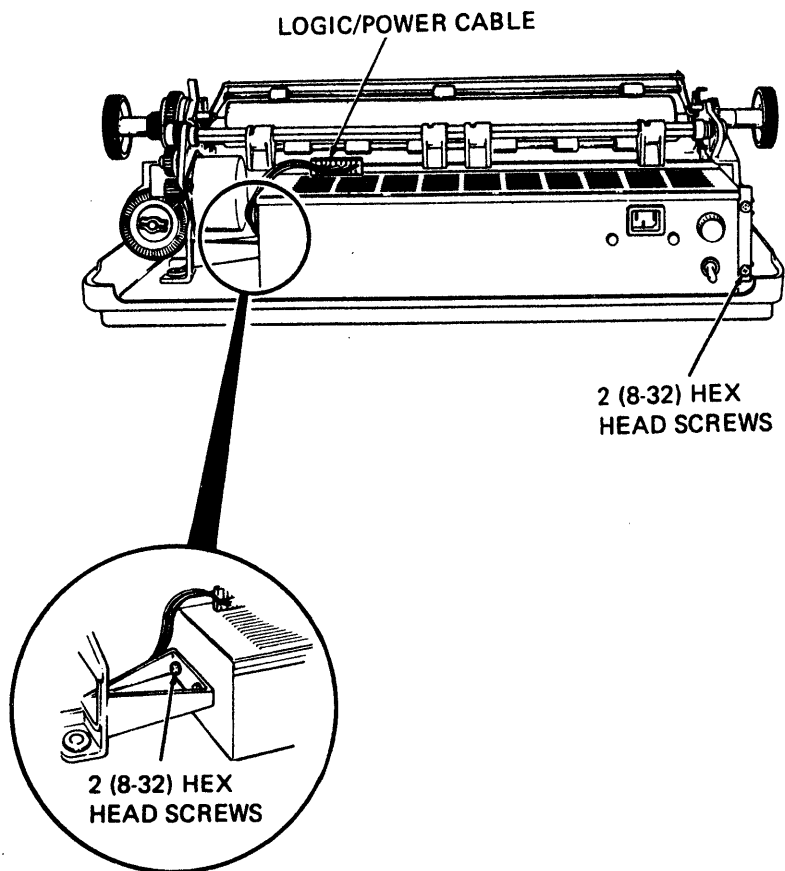

MA-2868

Figure 2-11 Power Supply Removal

## 2.8 KEYBOARD/OPERATOR CONTROL PANEL ASSEMBLY

The following procedures describe the removal and installation of the keyboard/operator control panel bezel assembly and the keyboard/operator control panel assembly.

### 2.8.1 Keyboard/Operator Control Panel Bezel Assembly

1. Perform the printer housing cover removal procedure (Paragraph 2.3).
2. Press the bezel retainer clips and rotate the keyboard/operator control panel bezel toward the front of the terminal (Figure 2-12).
3. Remove the keyboard/operator control panel connector from J6 on the logic board (Figure 2-12).
4. Lift the keyboard/operator control panel bezel straight up.

#### NOTE

When reinstalling the keyboard/operator control panel, be sure it is properly seated in the slots in the base assembly before rotating it forward to its original position.

5. To install the new keyboard/operator control panel bezel assembly, perform steps 1--4 in reverse order.

#### NOTE

If the new keyboard assembly has keycaps that are different from the keyboard that you removed, transfer the keycaps from the removed keyboard to the new keyboard. Refer to the Options chapter for more detail.

### 2.8.2 Keyboard/Operator Control Panel Assembly

1. Perform the keyboard/operator control panel bezel assembly removal procedure (Paragraph 2.8.1).
2. Place the bezel assembly keyside down on piece of clean paper or protective cloth.
3. Remove the hex head screws securing the keyboard/operator control panel to the bezel assembly (Figure 2-13).
4. To install the new keyboard/operator control panel assembly, perform steps 1--3 in reverse order.

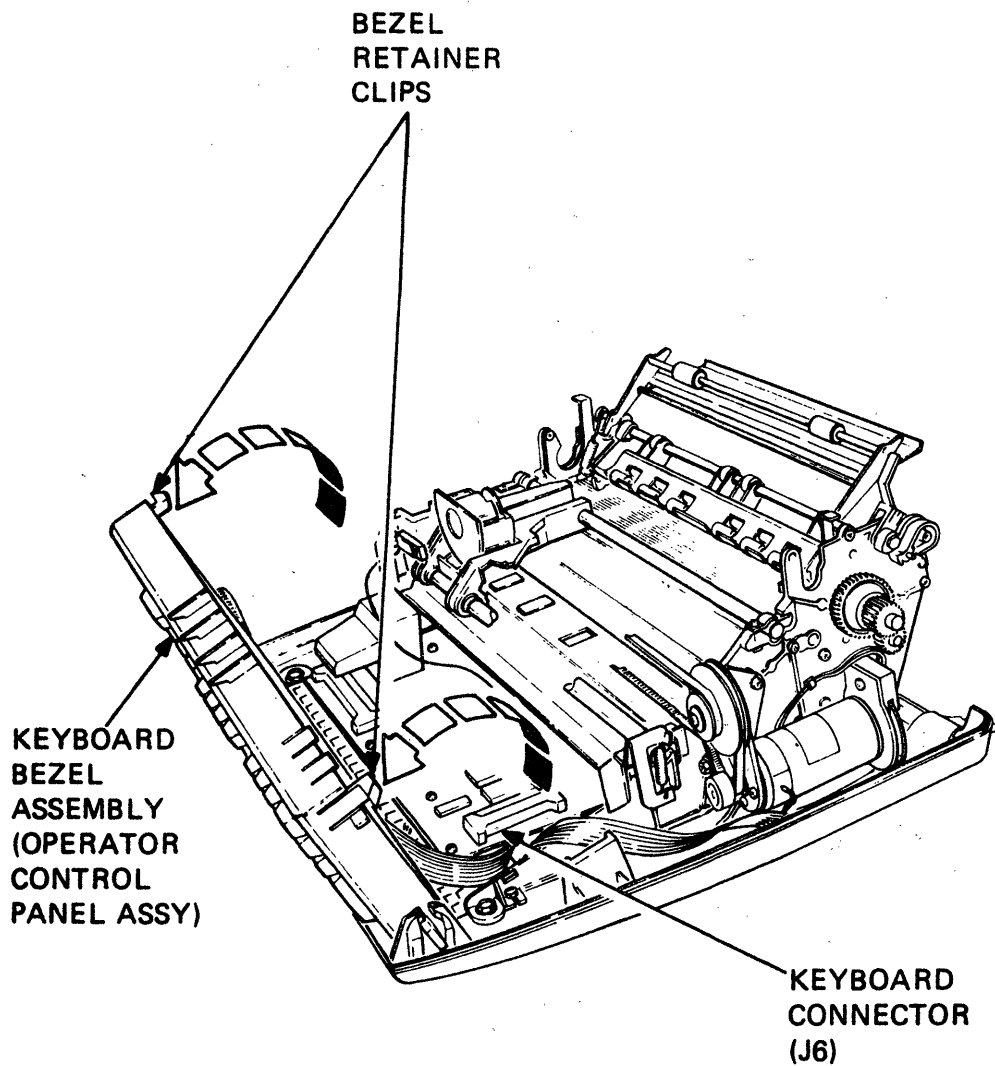

MA-8971D

Figure 2-12 Keyboard/Operator Control Panel Bezel Removal

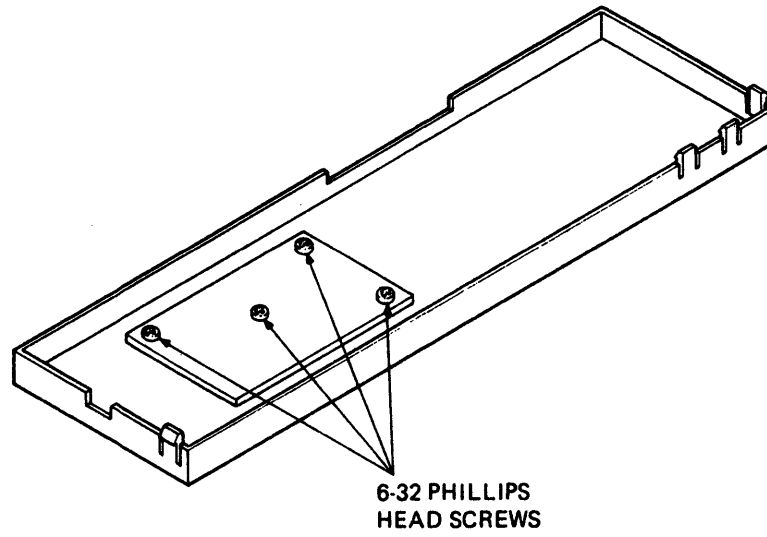
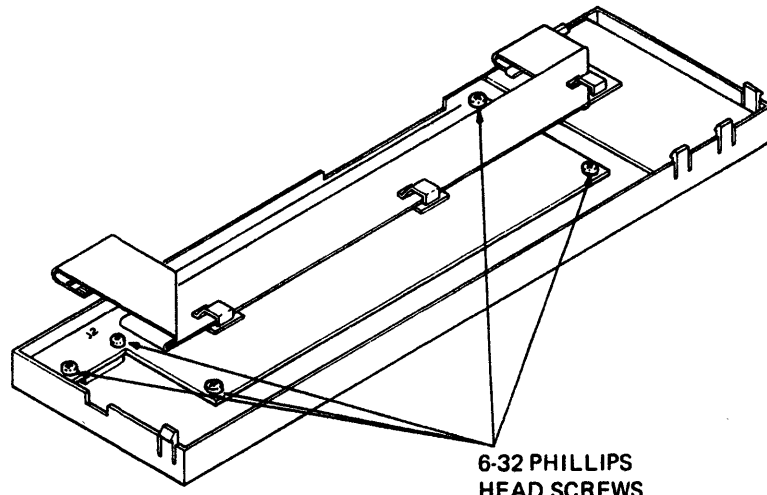

MA-8975

Figure 2-13 Keyboard/Operator Control Panel Removal

## 2.9 LOGIC BOARD

The following procedure describes the removal and installation of the logic board.

1. Perform the printer housing cover removal procedure (Paragraph 2.3).
2. Perform the keyboard/operator control panel removal procedure (Paragraph 2.8).
3. Remove the logic board safety cover (Figure 2-14).
4. Using a #2 phillips head screwdriver, remove the five phillips head screws securing the logic board to the base assembly (Figure 2-15).
5. Slide the logic board toward the front of the terminal.

### NOTE

When installing a new logic board, be sure that the rear edge of the logic board lines up with the corresponding slot in the dual PC card support.

Refer to Figure 2-16 for steps 6 through 12.

6. Disconnect the encoder cable from J3 on the logic board.
7. Disconnect the EIA communication cable from J7 on the logic board.
8. Disconnect the logic/power cable from J4 on the logic board.
9. Disconnect the servo motor cable from J1 on the logic board.
10. Disconnect the stepper motor cable from J2 on the logic board.
11. Disconnect the printhead ribbon cable from J5 on the logic board.
12. Disconnect any option connectors from J8 and J9 on the logic board.

13. Remove the logic board.

**NOTE**

Before discarding the faulty logic board, check the jumper and ROM configuration. Transfer any optional DPS ROMs from the removed logic board to the new logic board. Cut the jumpers from the new board that are removed on the faulty logic board. Refer Chapter 3 for more detail.

14. To install a new logic board, perform steps 1-13 in reverse order.
15. Refer to the status message and restore the original features.



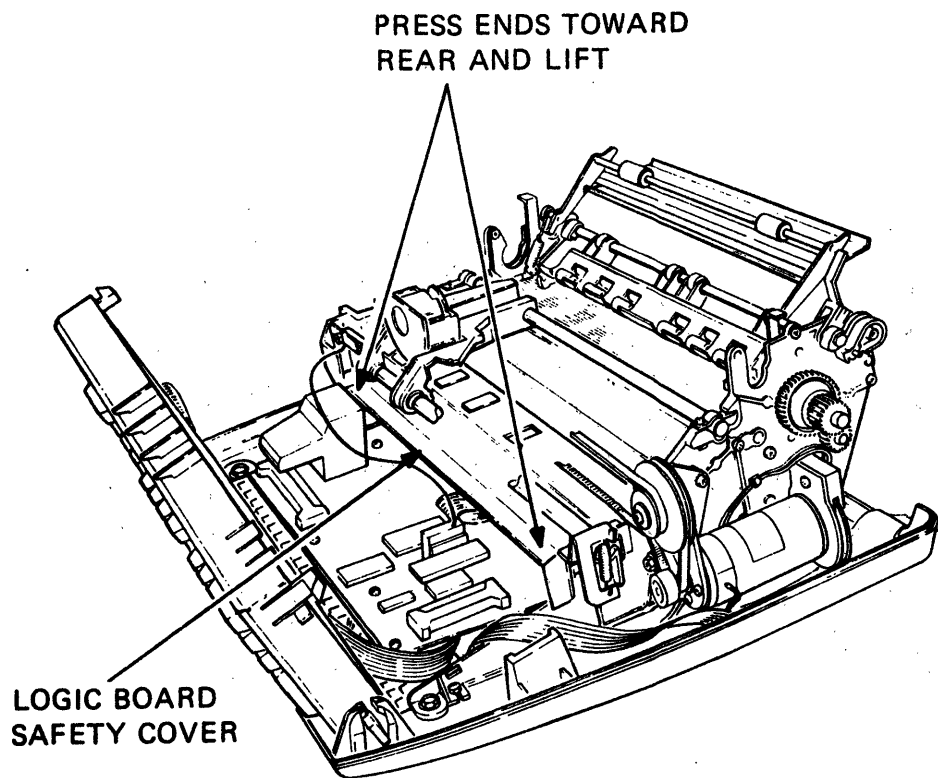

MA-8971

Figure 2-14 Logic Board Safety Cover Removal

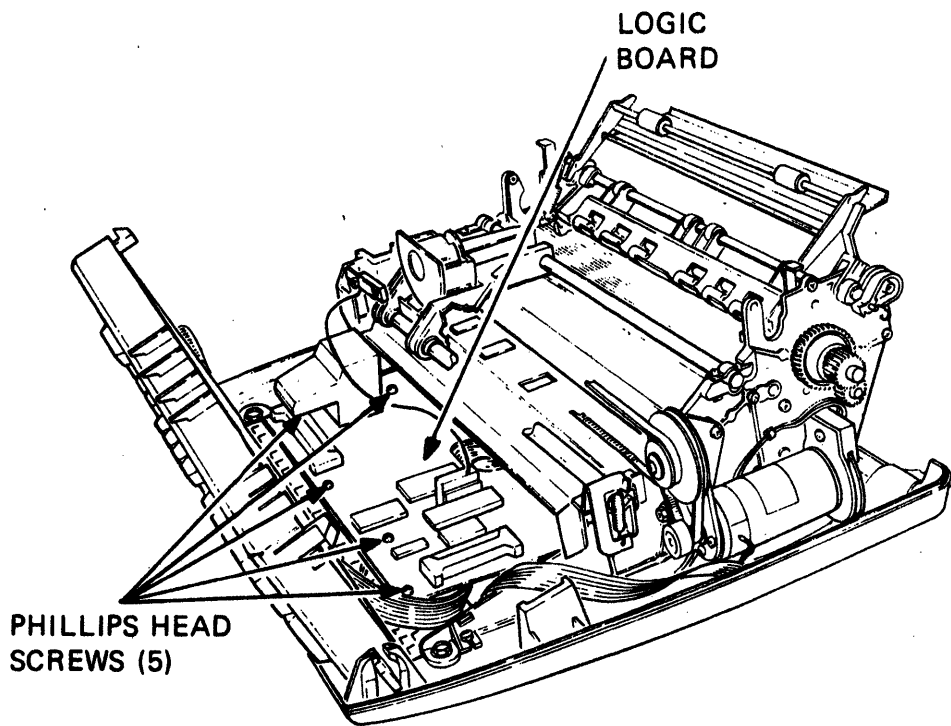

MA-8971A

Figure 2-15 Logic Board Removal

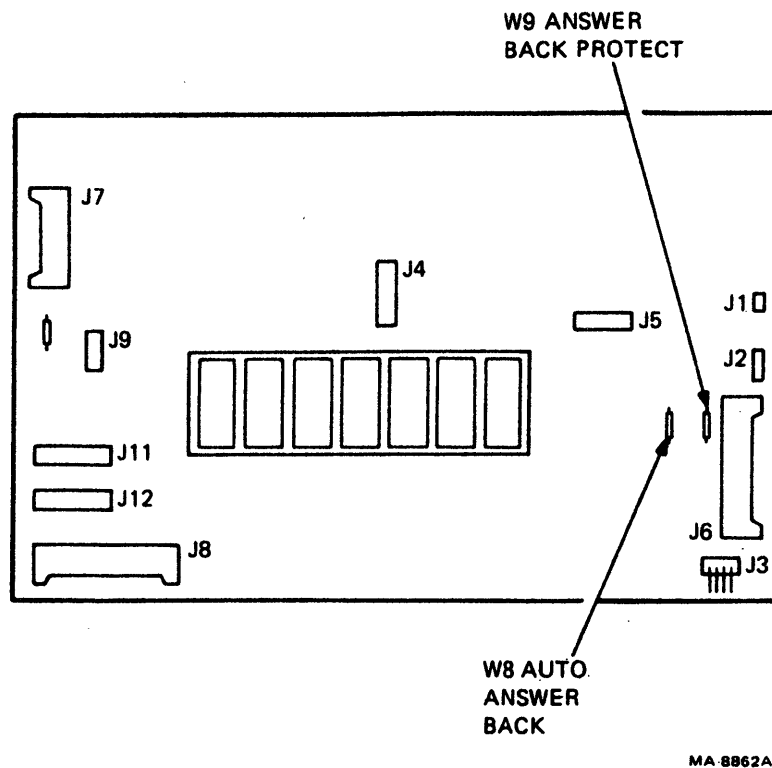

Figure 2-16 Logic Board Cable Connectors

## 2.10 PRINTER MECHANISM

The following procedure describes the removal and installation of the printer mechanism.

1. Perform the printer housing cover removal procedure (Paragraph 2.3).
2. Perform the keyboard/operator control panel assembly removal procedure (Paragraph 2.8).
3. Remove the rear insert (Figure 2-17).
4. Remove the four hex-head screws that secure the printer mechanism to the base (Figure 2-18).
5. Remove encoder wires from clip on base.
6. Lift the printer mechanism straight up.
7. To install a new printer mechanism, perform steps 1--5 in reverse order.

## 2.11 ANTIBACKLASH GEAR

The following procedure describes the removal and installation of the antibacklash gear.

1. Perform the printer housing removal procedure (Paragraph 2.3).
2. Using retainer clip pliers remove the C clip that secures the antibacklash gear (Figure 2-19).
3. Remove the antibacklash gear and washers.
4. To install the new antibacklash gear, perform steps 1--3 in reverse order.

### NOTE

Before reinstalling the printer housing cover, check that movement of the antibacklash gear is possible and the gear is not jammed.

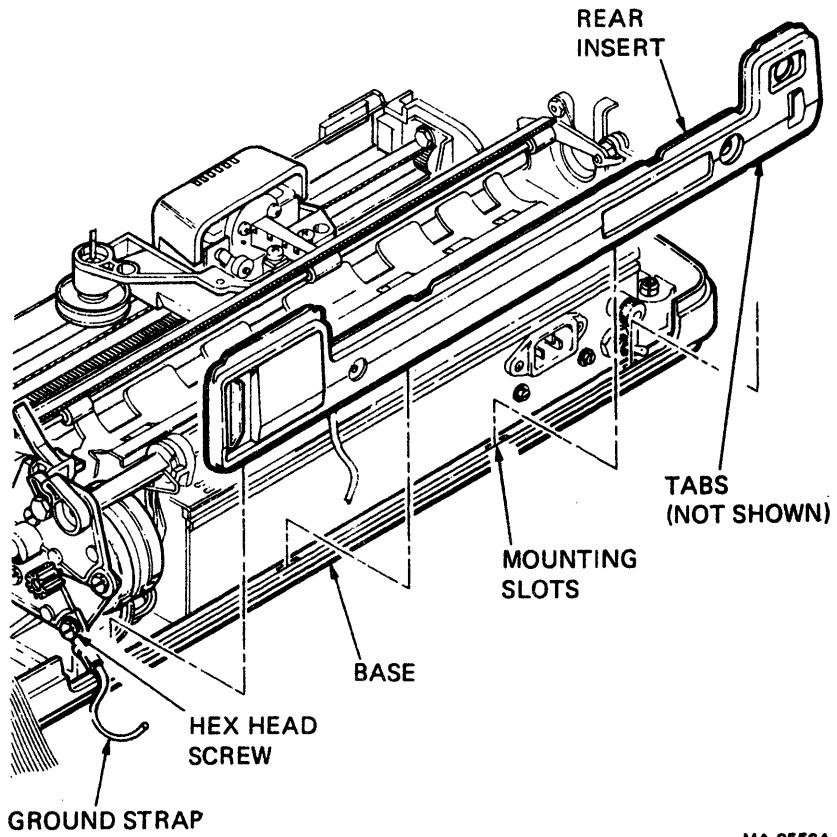
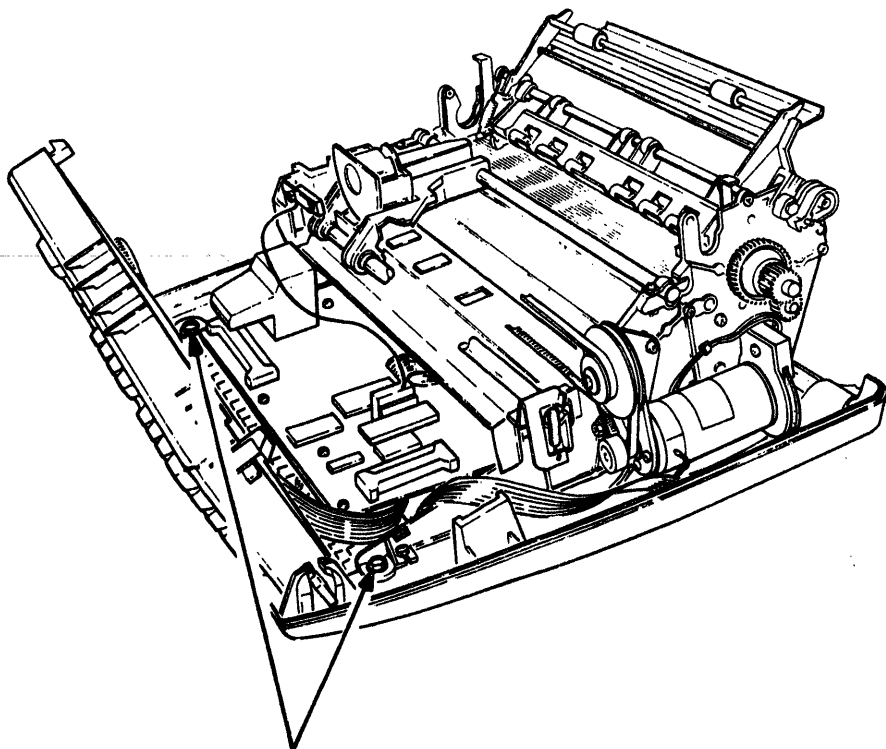

Figure 2-17 Rear Insert Removal



8-32 HEX  
HEAD SCREW  
(4 PLACES)

MA-8971B

Figure 2-18 Printer Mechanism Removal

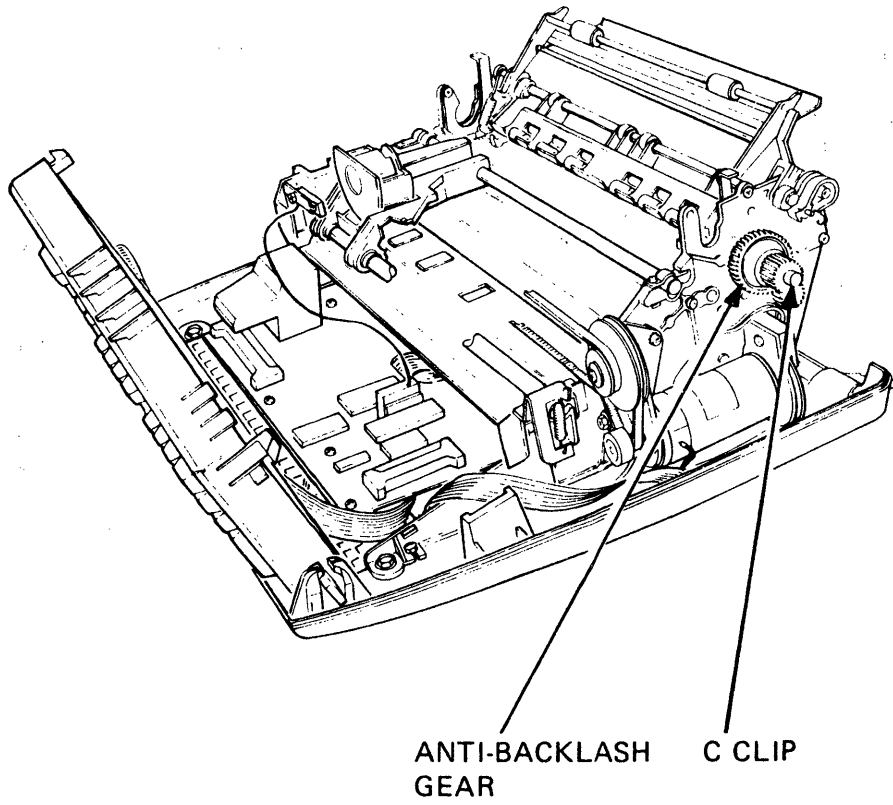

MA-8971C

Figure 2-19 Antibacklash Gear Removal

## 2.12 LINE FEED MOTOR ASSEMBLY

The following procedure describes the removal and installation of the line feed motor assembly.

1. Perform the printer housing cover removal procedure (Paragraph 2.3).
2. Remove the rear insert (Figure 2-17).
3. Press the bezel retainer clips and rotate the keyboard/operator control panel assembly toward the front of the terminal (Figure 2-12).
4. Remove the logic board safety cover (Figure 2-14).
5. Disconnect the line feed motor connector from J2 on the logic board (Figure 2-16).
6. Remove the four (1-4) slotted hex head screws that secure the line feed motor to the right side plate (Figure 2-20).
7. Remove the ground strap and note its position (Figure 2-20).
8. Carefully feed the line feed motor cable through the printer mechanism and remove the stepper motor assembly.
9. To install the line feed motor perform steps 1--8 in reverse order.



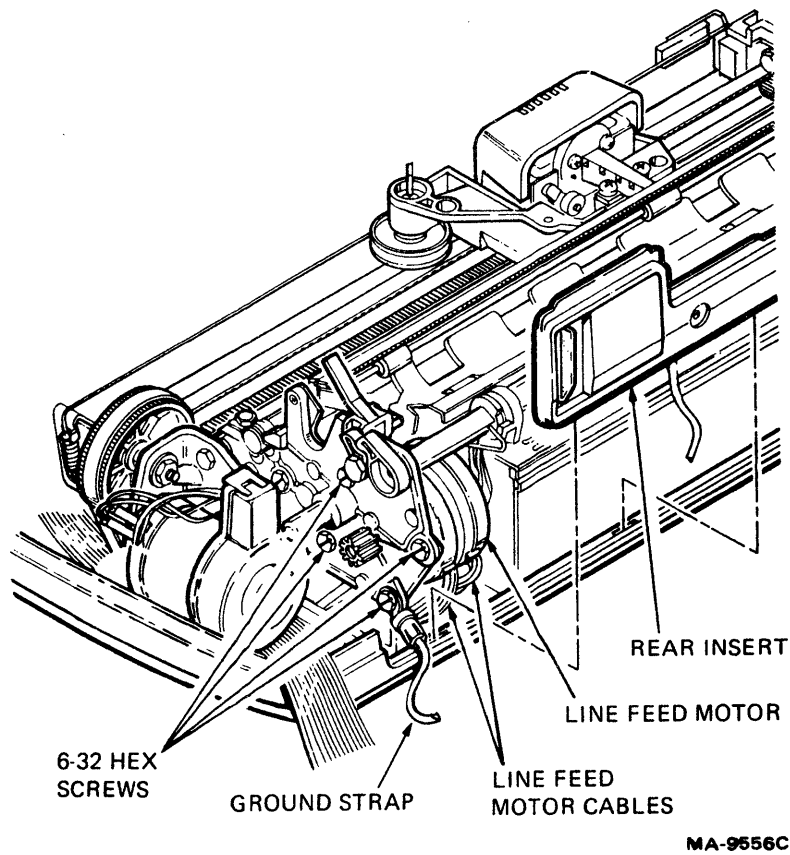

Figure 2-20 Line Feed Motor Assembly Removal

### 2.13 SERVO MOTOR AND ENCODER ASSEMBLY

The following procedure describes the removal and installation of the servo motor and encoder assembly.

1. Perform the printer housing cover removal procedure (Paragraph 2.3).
2. Rotate the keyboard/operator control panel toward the front (Figure 2-12).
3. Remove the logic board safety cover (Figure 2-14).
4. Disconnect the encoder connector from J3 on the logic board (Figure 2-16).
4. Disconnect the servo drive connector from J1 on the logic board (Figure 2-16).

#### NOTE

Make sure that the original cable routing is followed when installing a new assembly.

5. Perform the pulley/tension assembly removal procedure (Paragraph 2.14).
6. Remove the four hex-head screws securing the printer mechanism to the base assembly (Figure 2-18).
7. Remove the three hex-head screws securing the servo motor/encoder assembly to the right side plate (Figure 2-21).
8. Lift the servo motor/encoder assembly and the shim washers free from the right side plate.
9. To install the new servo motor and encoder, perform steps 1--8 in reverse order.

### 2.14 PULLEY/TENSION ASSEMBLY

The following procedure describes the removal and installation of the pulley/tension assembly.

1. Perform the printer housing cover removal procedure (Paragraph 2.3).
2. Remove the spring from the bottom of the flexure retainer (Figure 2-22).
3. Lift the flexure retainer over the retainer screw (Figure 2-22).
4. Remove the pulley and tension assembly.
5. To install a new pulley/tension assembly, perform steps 1--4 in reverse order.

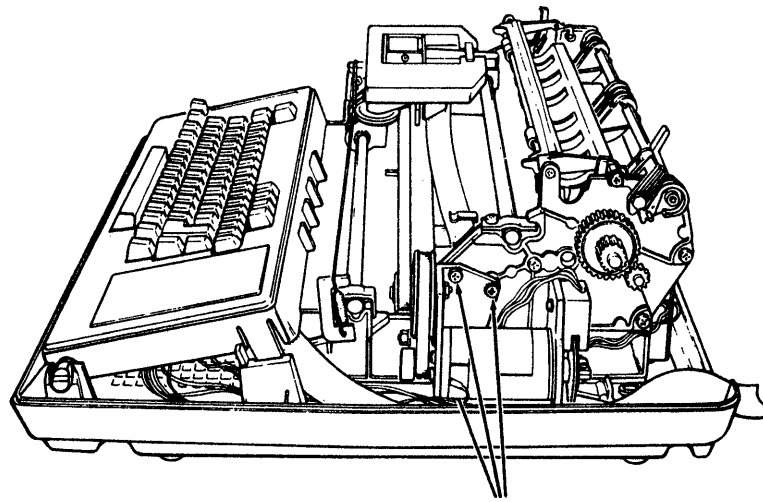

6-32 HEX  
HEAD SCREWS

MA-2879

Figure 2-21 Servo Motor/Encoder Removal

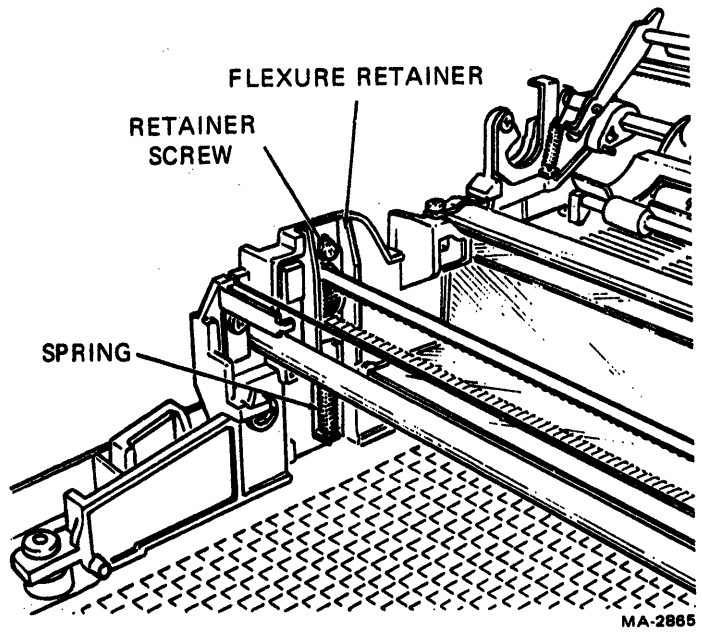

Figure 2-22 Pulley/Tension Assembly Removal

## 2.15 TIMING BELT

The following procedure describes the removal and installation of the timing belt.

1. Perform the printhead removal procedure (Paragraph 2.2).
2. Perform the printer housing cover removal procedure (Paragraph 2.3).
3. Perform the pulley/tension assembly removal procedure (Paragraph 2.14).
4. Remove the timing belt from the servo motor pulley (Figure 2-23).
5. Remove the clip that secures the timing belt to the carriage assembly.
6. Slip the timing belt out of the carriage assembly. Remove the timing belt.
7. To install the new timing belt, perform steps 1--6 in reverse order.

## 2.16 RIBBON DRIVE CABLES

The following procedure describes the removal and installation of the ribbon drive cables.

1. Perform the printer housing removal procedure (Paragraph 2.3).
2. Remove the top ribbon cable by removing the cable ball from the left side plate (Figure 2-23).
3. Remove the spring that secures the cable to the clamp.
4. Remove the ribbon drive cable.
5. Remove the bottom ribbon cable by removing the cable ball from the right side plate (Figure 2-24).
6. Remove the spring that secures the cable to the clamp.
7. Remove the ribbon drive cable.
8. To install a new ribbon drive cable, perform steps 1--7 in reverse order.

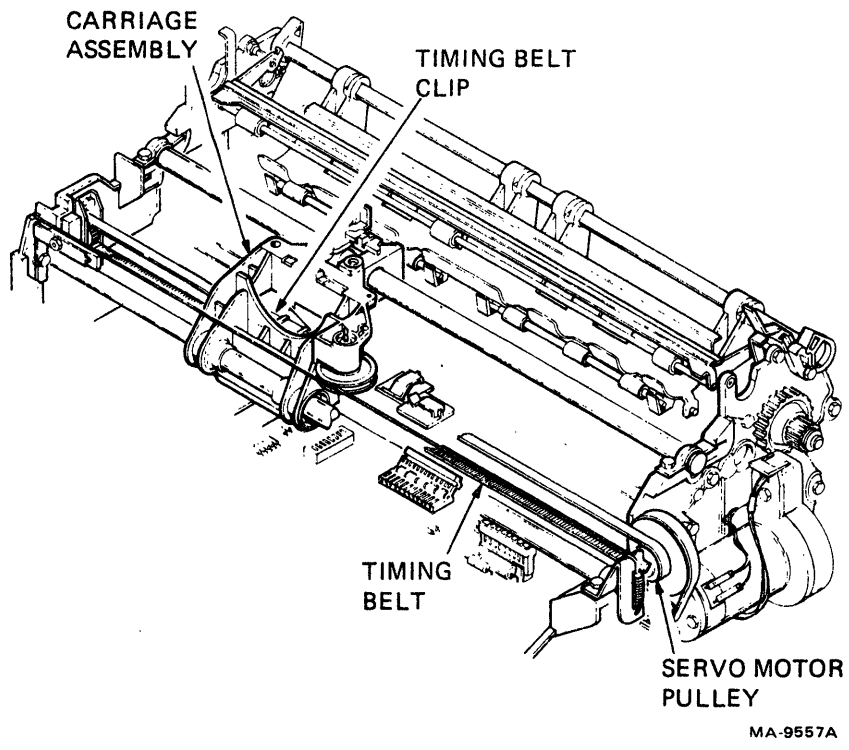

Figure 2-23 Timing Belt Removal

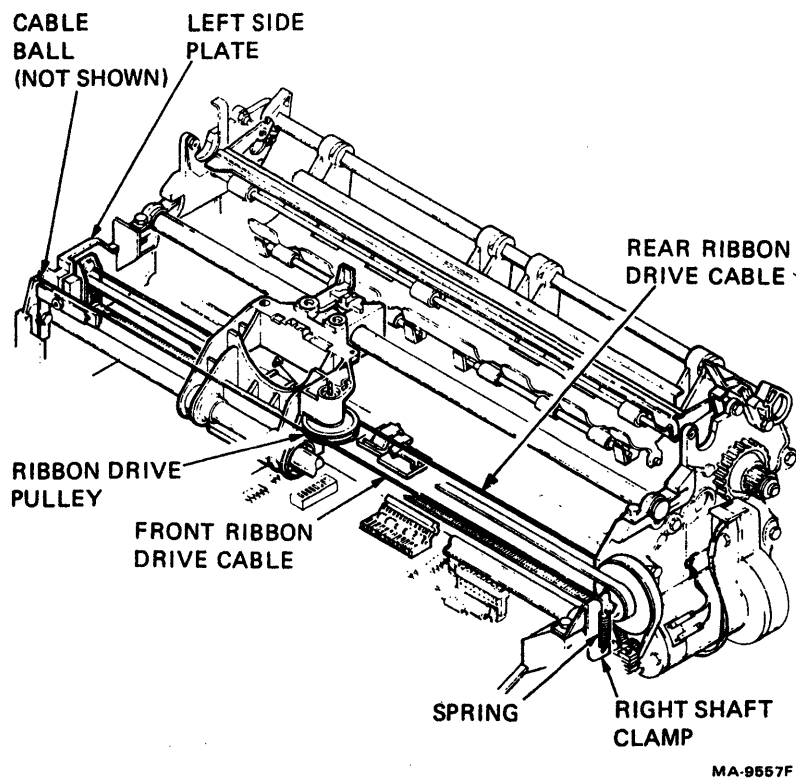

Figure 2-24 Ribbon Drive Cables Removal

## 2.17 CARRIAGE ASSEMBLY

The following procedure describes the removal and installation of the carriage assembly.

1. Perform the printhead removal procedure (Paragraph 2.2).
2. Perform the printer housing removal procedure (Paragraph 2.3).
3. Remove the clip that secures the timing belt to the carriage assembly (Figure 2-25).
4. Slide the timing belt from the carriage assembly.
5. Perform the ribbon drive cables removal procedure (Paragraph 2.16). Slide the carriage to the left.
6. Remove the rear carriage shaft by removing the two hex-head screws and shaft clamps at the each end of the rear carriage shaft (Figure 2-25).
7. Loosen the two hex-head screws at each end of the front carriage shaft (Figure 2-25).
8. Remove the front carriage shaft by sliding it out toward the left side plate.
9. Remove the carriage assembly.
10. To install a new carriage assembly perform steps 1--9 in reverse order.

### NOTE

Slide the new carriage assembly fully to the right and then to the left. If it does not slide smoothly, rotate both front and rear carriage shafts as needed.



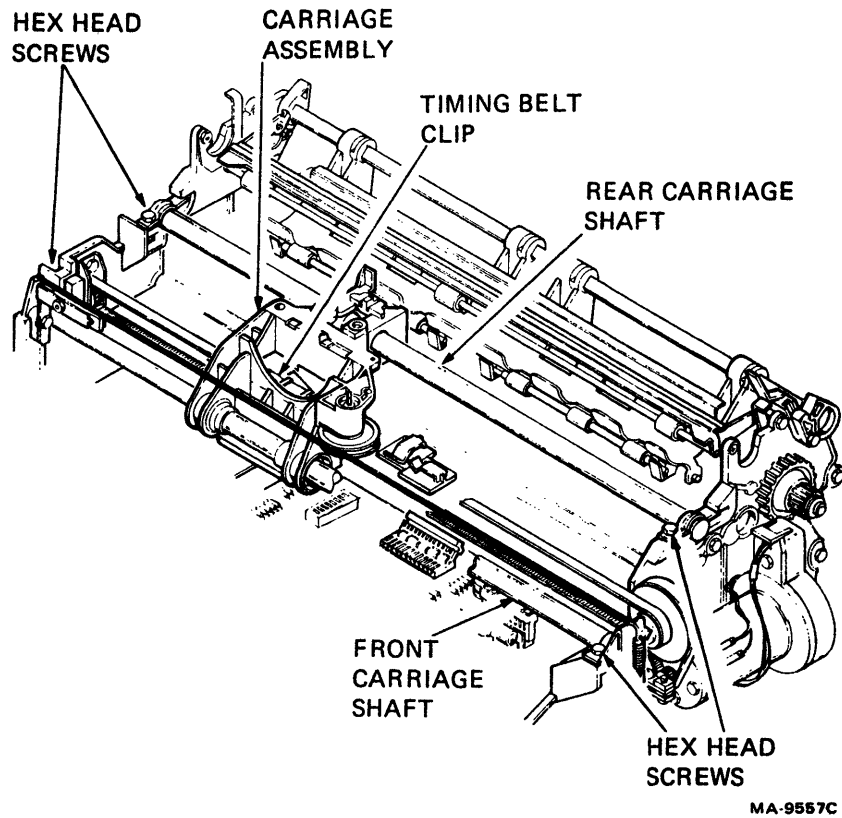

Figure 2-25 Carriage Assembly Removal

## 2.18 PAPER OUT DETECTION SWITCH

The following procedures describe removal and installation of the paper out detection switch.

1. Perform the printer housing cover removal procedure (Paragraph 2.3)
2. Press the bezel retainer clips and rotate the bezel towards the front of the terminal (Figure 2-12).
3. Disconnect the paper out cables at the microswitch (Figure 2-26).
4. Using a 1/4 inch open end wrench, loosen the bottom switch support plate hex-head screw (Figure 2-27).
5. Using the 1/4 inch open end wrench, remove the top switch support plate key head screw (Figure 2-27). Slide the switch support plate off the bottom screw.

### NOTE

When a new switch support plate is installed it must be adjusted before being secured to the printer mechanism. Be sure that the two screws are only finger tight before this adjustment is made.

6. Remove the microswitch and detent helper spring from the switch support plate by removing the two (4-40 X 5/8) fillister screws and two (4-40) keep nuts (Figure 2-27).
7. Press the ends of the tension spring slightly together (Figure 2-28). Slide the switch actuator and spring off the paper out shaft.

### NOTE

Make sure that the spring is held in place between the retaining pins on the paper out override lever and the switch actuator when reinstalling this assembly (Figure 2-28).

8. Remove the spring from the switch activator (Figure 2-28).
9. Slide the paper out override lever off the paper out shaft (Figure 2-28).

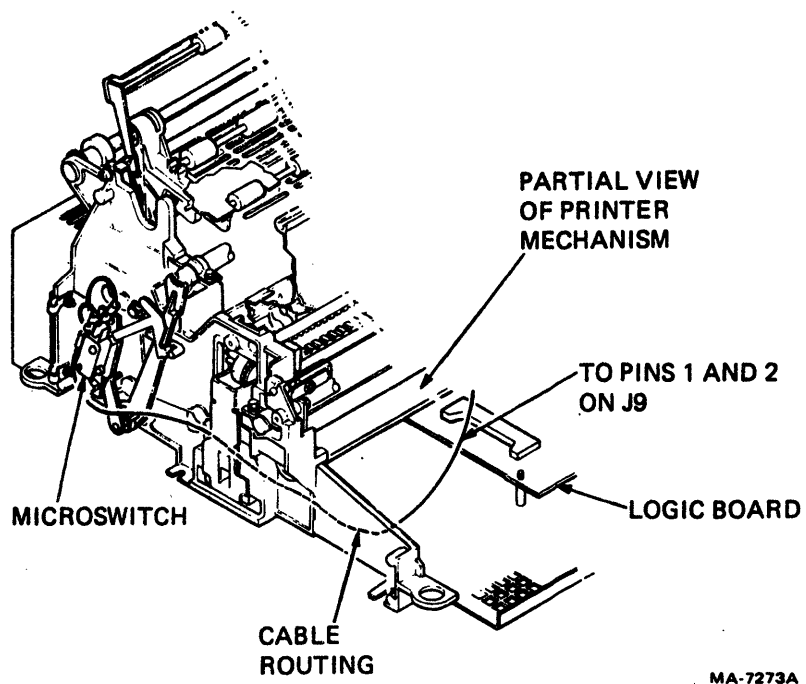

Figure 2-26 Paper Out Switch Cable Removal

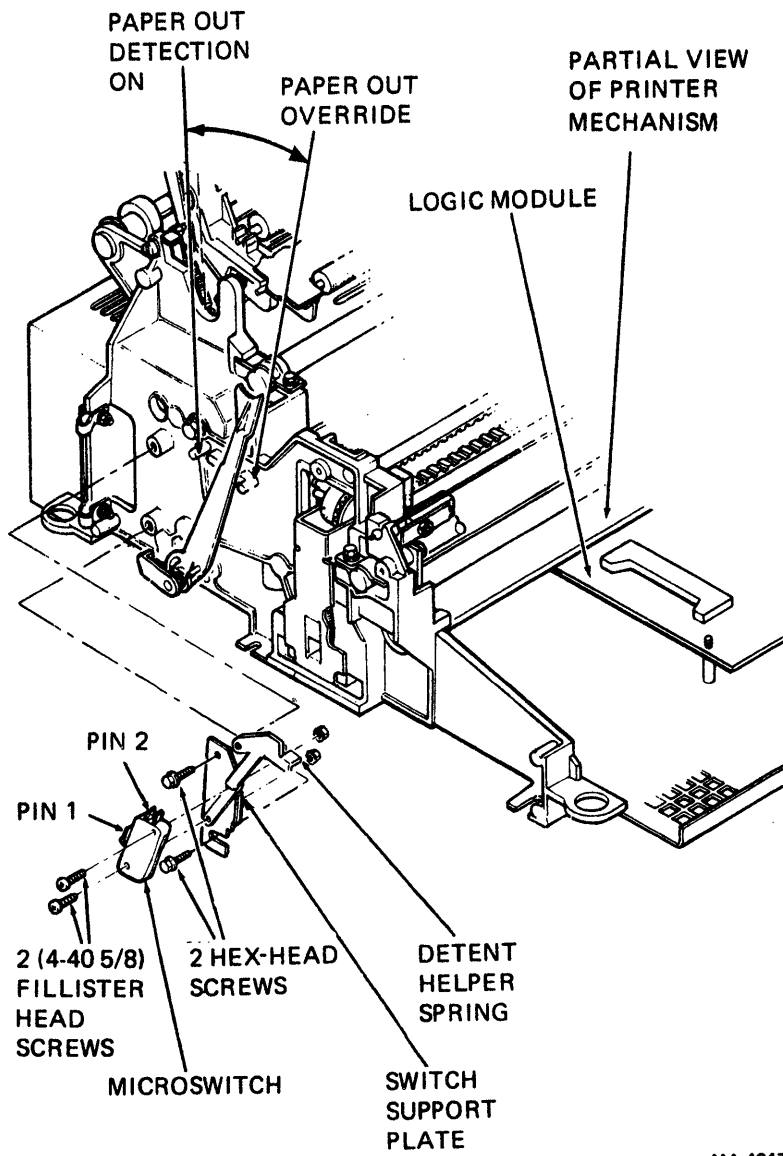

Figure 2-27 Paper Out Detection Switch Removal

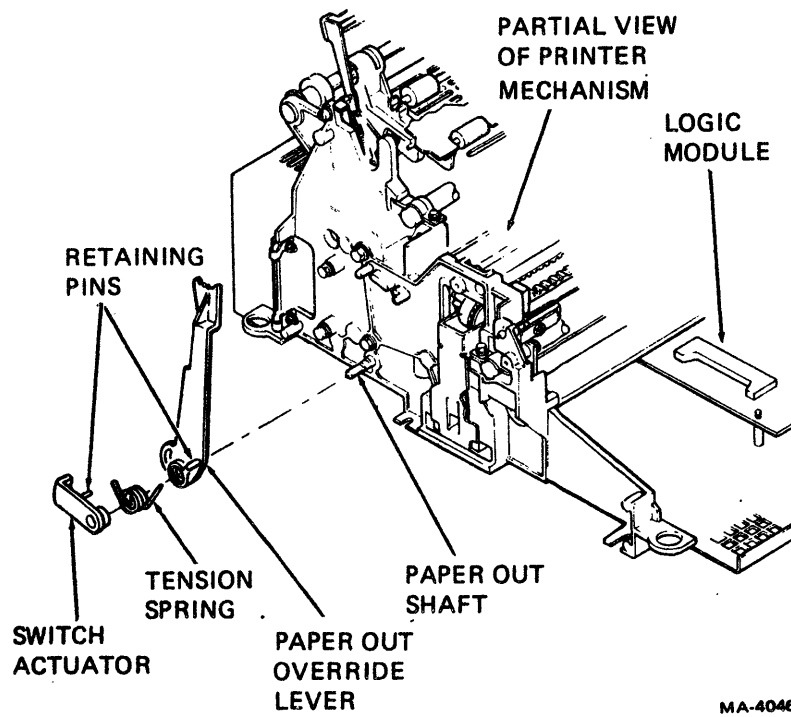

Figure 2-28 Paper Out Override Lever Removal

10. To install a new paper out detection switch, reverse steps 1 through 9. Make the following adjustment as part of step 5.
  - a. With the paper out override lever in the detect position (Figure 2-29), adjust the switch support plate to activate (press) the microswitch. Using a 1/4 inch open end wrench, tighten the top switch support plate hex-head screw (Figure 2-27).

**NOTE**

When the paper out override lever is in the detect position the paper out detection option will operate. When switched to the override position, the paper out detection option will not operate.

## 2.19 PRINTHEAD CABLE ASSEMBLY

The following procedures describe removal and installation of the printhead cable assembly.

1. Perform the printer housing cover removal procedure (Paragraph 2.3).
2. Perform the printhead removal procedure (Paragraph 2.2).
3. Perform the ribbon cables removal procedure (Paragraph 2.16).
4. Remove the rear carriage shaft by removing the two hex head screws that secure the shaft at each end (Figure 2-25).
5. Remove the clip that secures the timing belt to the carriage assembly.
6. Rotate the carriage toward the front of the terminal (Figure 2-30).
7. Lift the tab and remove the printhead cable from the carriage assembly (Figure 2-30).
8. Press the bezel retainer clips and rotate the bezel towards the front of the terminal (Figure 2-12).
9. Remove the logic board safety cover (Figure 2-14).
10. Disconnect the printhead cable from the logic board (Figure 2-16).
11. To install a new printhead cable, reverse steps 1 through 10.

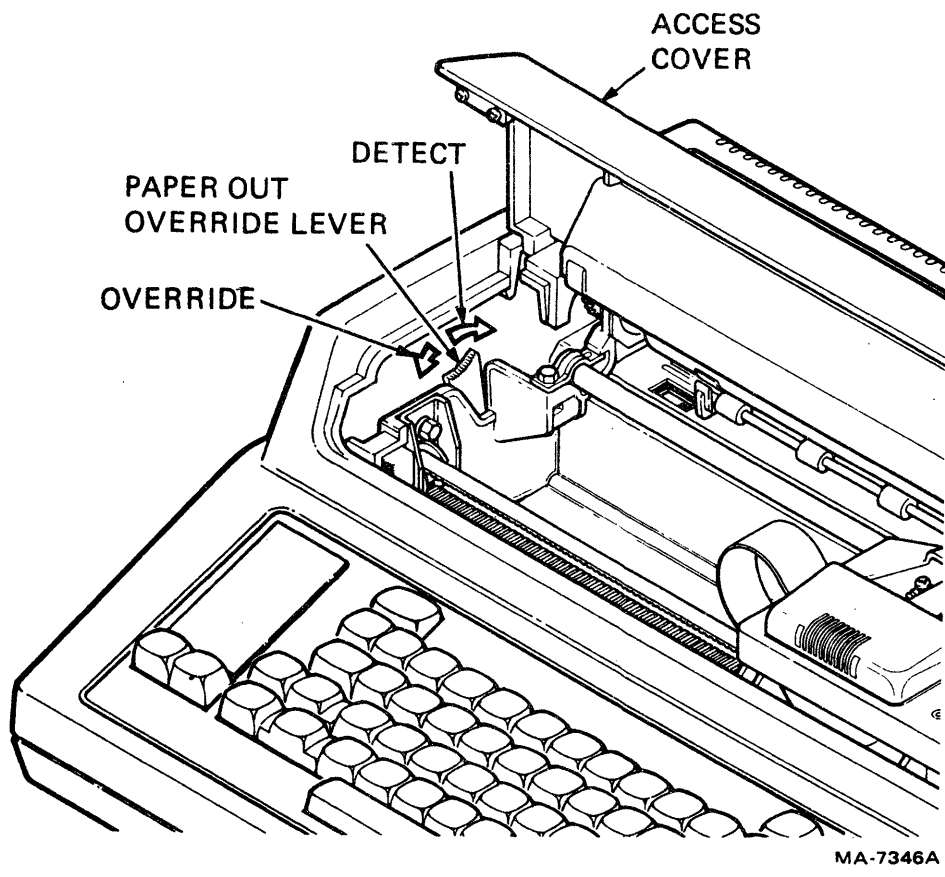

MA-7346A

Figure 2-29 Paper Out Override Lever

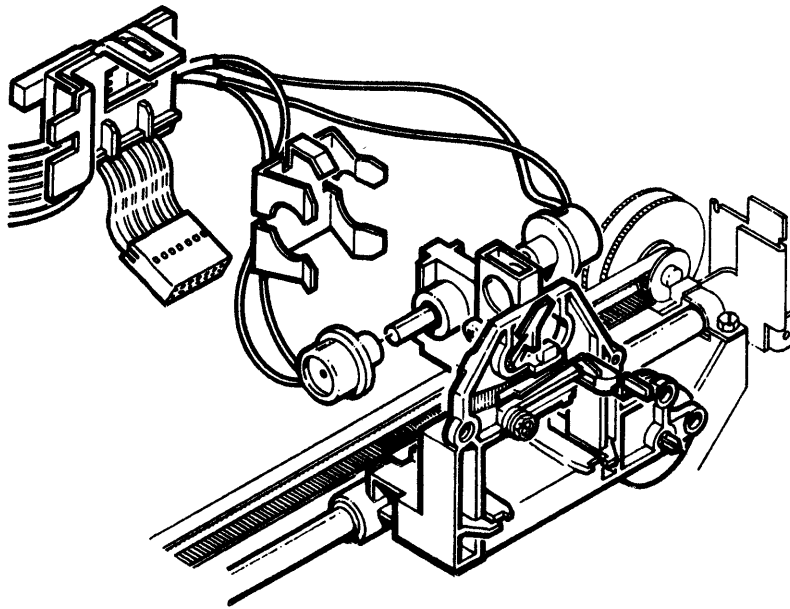

MA-8973

Figure 2-30 Print Head Cable Removal



## 2.20 PAPER LOW JACK CABLE

The following procedure describes the removal and installation of the paper low jack cable.

1. Perform the printer housing cover removal procedure (Paragraph 2.3)
2. Press the bezel retainer clips and rotate the bezel towards the front of the terminal (Figure 2-12).
3. Remove the rear insert (Figure 2-17).
4. Locate the paper low jack and remove the attached nut and washer (Figure 2-31). Remove the jack from the insert.
5. Disconnect the paper low cable connector from J9 on the logic board (Figure 2-16). Carefully pull the cable and connector through the printer mechanism to remove it. Note the cable routing for use during replacement.
6. To install a new paper low jack cable, perform the reverse of steps 1 through 5.

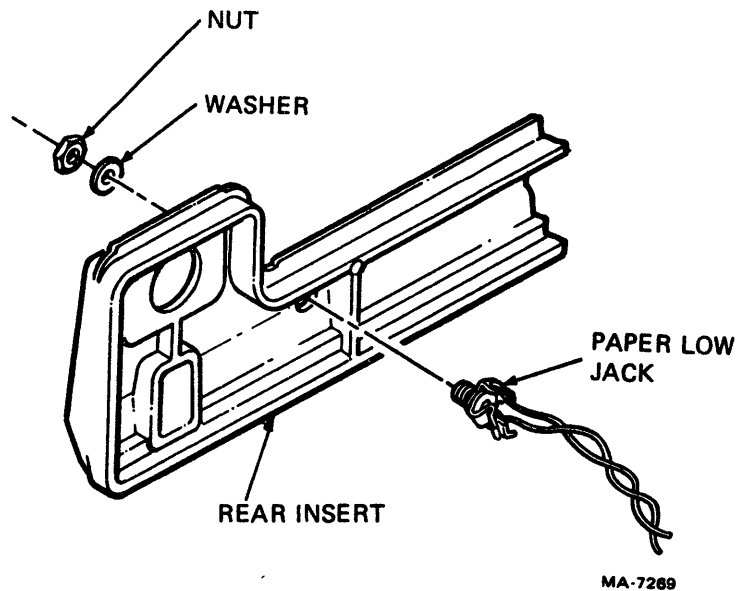

Figure 2-31 Paper Low Jack Removal



### 3 LOGIC BOARD CONFIGURATIONS

#### 3.1 GENERAL

This chapter describes the different logic board configurations available for the LA100 terminals. It is important to check the logic board any time you replace it to verify that the configuration on the new board matches the removed board. This chapter is divided into 3 sections:

- Jumper selectable features (Paragraph 3.2)
- EIA Circuit Jumpers (Paragraph 3.3)
- DPS ROMs (Paragraph 3.4)

#### 3.2 Jumper Selectable Features

The LA100 terminals have jumpers used to select features. Two jumpers are used for the Letterwriter 100, 3 for the Letterprinter 100 (Figure 3-1). Their functions are described in Chapter 5.

Before you replace a logic board, be sure to verify that the jumper configuration on the new logic board matches the removed logic board. After you replace the logic board print the status message to verify that the proper features are selected.

#### CAUTION

Make sure to remove the entire jumper. Any metal piece remaining may disturb the electronic operation of the terminal.

#### 3.3 EIA Circuit Jumpers

The LA100 terminals also have jumpers to disable some of the EIA communication circuits (Figure 3-1). Some of these jumpers may be removed to meet European communication requirements. The jumpers may also be removed for special communication requirements.

Before you replace a logic board, be sure to verify that the jumper configuration on the new logic board matches the removed logic board.

#### CAUTION

Make sure to remove the entire jumper. Any metal piece remaining may disturb the electronic operation of the terminal.

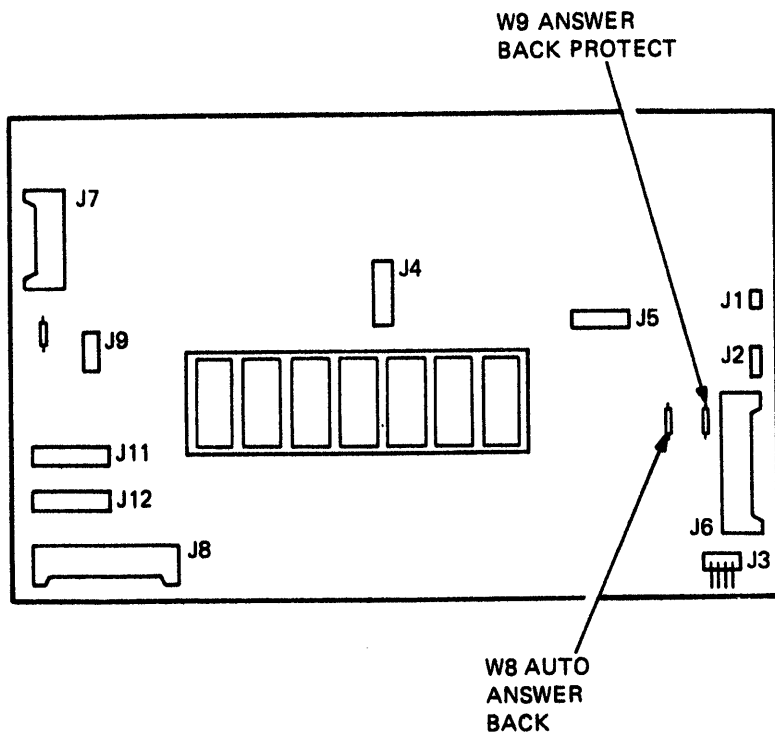

MA-8862A

Figure 3-1 Jumper Selectable Features

### 3.4 DPS ROMs

The LA100 terminals use Dot Pattern Sets (DPS) to select different fonts, character sets, or character pitches. There are 2 types of ROMs: plug in ROM and ROM cartridges. The plug in ROMs are installed inside the terminals in five slots (Figure 3-1). The ROM cartridges are used with the multiple font option.

Before you replace a logic board, be sure to verify that the ROM configuration on the new logic board matches the removed logic board. If not, take the ROMs from the removed logic board and install them into the new logic board. After you replace the logic board print the status message to verify that the proper features are selected.

#### CAUTION

Always hold ROM chips by the plastic body. Be careful not to touch the pins with your hands. Static electricity buildup on the hands can damage the chip.

#### 3.4.1 ROM removal

Perform the following procedure to remove a plug in ROM.

1. Locate the ROM chip on the logic board to be removed (Figure 3-1).
2. Insert tip of small slotted screwdriver between chip and receptacle and turn tool slightly at each end until pins are free (Figure 3-2). Do not use rocking motion while removing chip.
3. Remove the ROM chip. If possible, mount the original chip in a conductive carrier for storage.

#### 3.4.2 ROM replacement

Perform the following procedure to install a plug in ROM.

1. Ground your hand by touching a metallic part of the printer mechanism assembly. Then pick up the ROM.
2. With pin 1 of chip (identified by a small dot) located in the upper left corner, carefully engage all pins in the connector sockets. Be sure to install the chip as shown in Figure 3-2.
4. Gently press the chip straight in until it is fully seated. Do not use a rocking motion while installing the chip.
5. Check to be sure that all chip pins are engaged and that the dot is in the upper left corner.

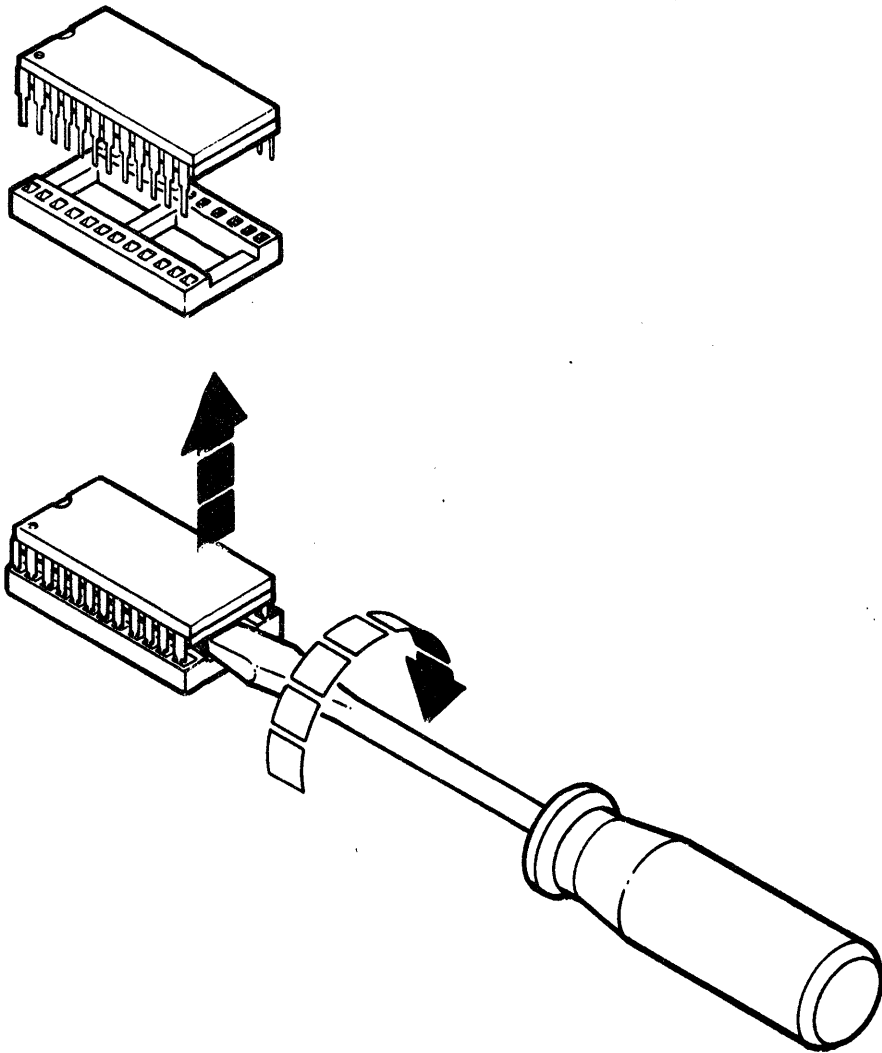

MA-8974

Figure 3-2 ROM Removal and Replacement

#### 4.1 GENERAL

This chapter provides test and repair information for the LA100 series terminal options. In general, tests are limited to those options that perform electrical or electro-mechanical operations.

Faulty mechanical options are usually detected by observing operation of the option. Repair procedures usually consist of replacing the entire option. In those cases where there are multiple components, the defective component may be replaced with the same component from a spares kit.

The following options are covered in this chapter. Refer to the paragraph listed for both the troubleshooting and repair procedures.

LAX34-RL Roll Paper Holder Option (Paragraph 4.2)  
LAX34-AL Tractor Option (Paragraph 4.3)  
LAX34-LL Paper Low Detection Option (Paragraph 4.4)  
LAX34-CL 20 mA Current Loop Option (Paragraph 4.5)  
LAX34-KL Numeric Keypad Option (Paragraph 4.6)  
LA10X-FL Multiple Font Option (Paragraph 4.7)

#### 4.2 LAX34-RL Roll Paper holder option

##### 4.2.1 Checkout Procedure

Perform the following visual checks of the roll paper holder assembly.

1. Check the roll paper holder for physical damage.
2. Check the mandrel and paper roll retainers for damage or missing parts (Figure 4-1).
3. Check the apron for proper spring-loaded operation (Figure 4-1).

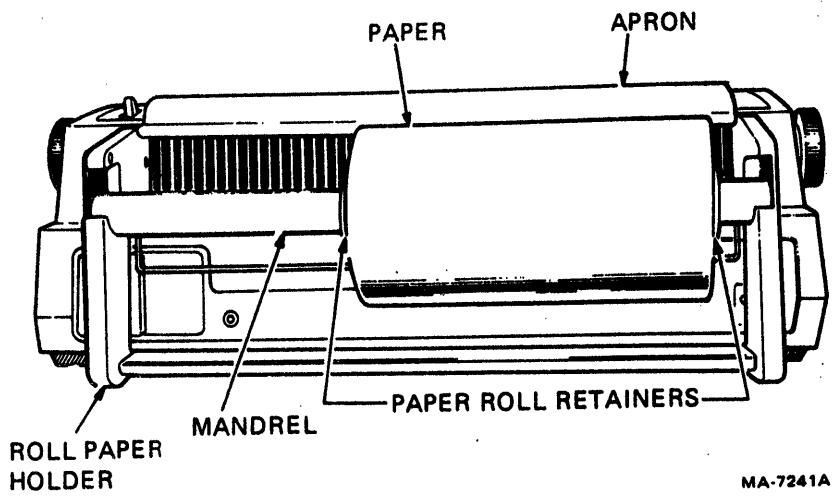

Figure 4-1 Roll Paper Holder Assembly



#### 4.2.2 Roll Paper Holder Replacement

The following procedure describes replacement of the roll paper holder.

1. Remove the mandrel and paper roll from the roll paper holder (Figure 4-1).
2. Pull the bottom of the holder away from the terminal until free. Lift the roll paper holder off the terminal (Figure 4-2).
3. To install a new roll paper holder, perform the reverse of steps 1 and 2. Be sure that the tabs on the holder are engaged in the mounting notches on the terminal (Figure 4-2).

#### 4.3 LAX34-AL Tractor Option

##### 4.3.1 Checkout Procedure

Perform the following visual checks of the tractor assembly.

1. Check the tractor adjust levers for proper clamping and releasing action (Figure 4-3).
2. Open the tractor covers. The left and right paper drive sprockets should align vertically (Figure 4-3).
3. Rotate the paper adjust knobs. The sprockets should move smoothly and evenly.

##### 4.3.2 Tractor Assembly Replacement

The following procedure describes replacement of the tractor assembly.

1. Turn the power ON/OFF switch located at the rear of the terminal to the OFF position.
2. Press the two tractor release levers and lift the tractor assembly off the terminal (Figure 4-4).
3. To install a new tractor assembly, perform the reverse of step 2. Be sure that the bail bar is lifted away from the platen and located behind the tractor assembly.

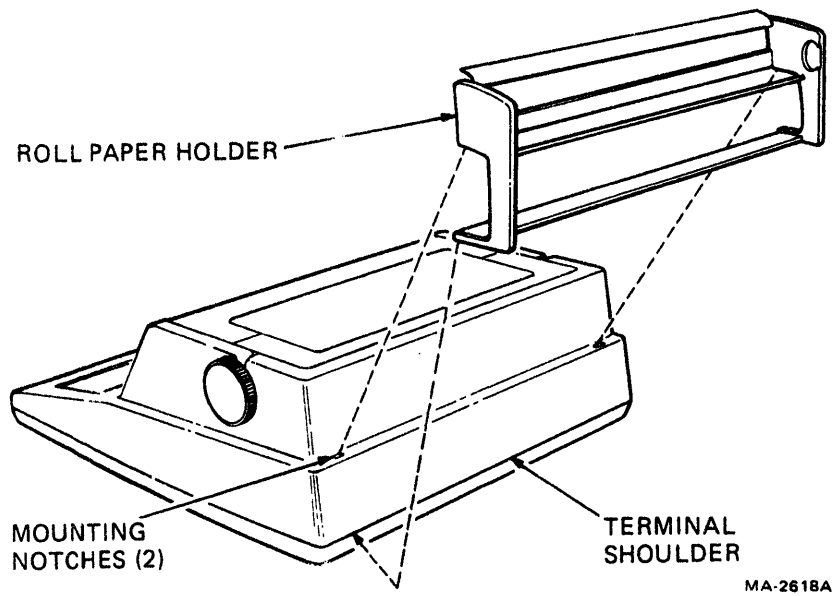
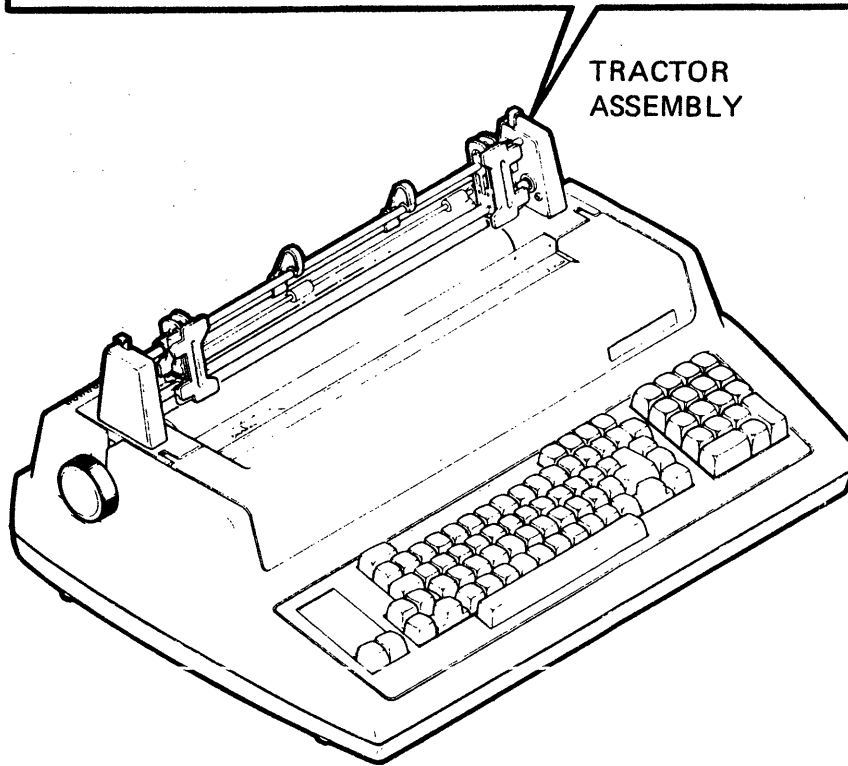
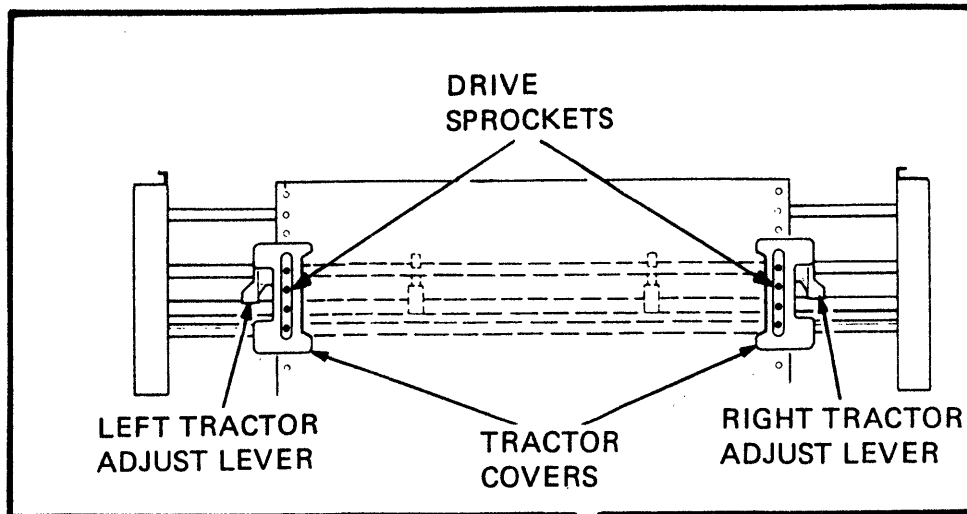
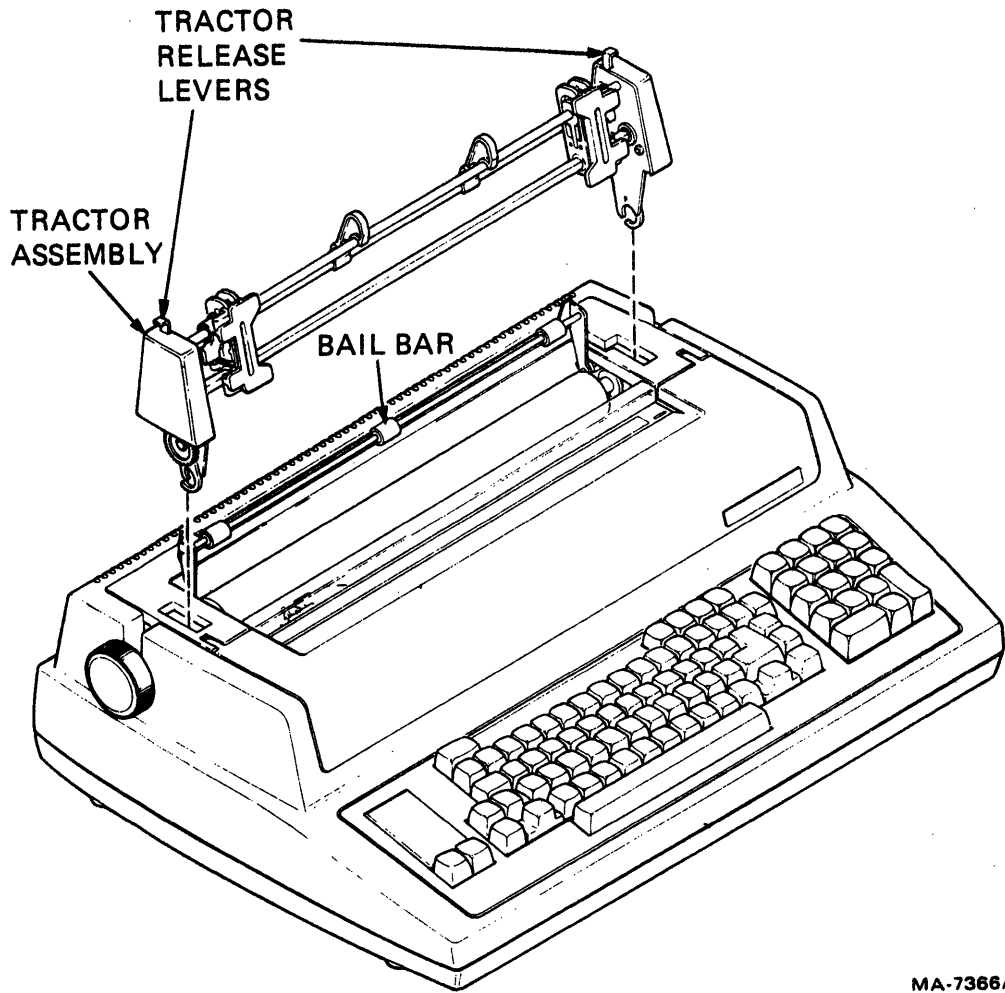

Figure 4-2 Roll Paper Holder Assembly



MA-7351A

Figure 4-3 Tractor Assembly



MA-7366A

Figure 4-4 Tractor Removal

#### 4.4 LAX34-LL Paper Low Detection Option

##### 4.4.1 Checkout Procedure

Perform the following procedure to check out the paper low detection option.

1. Remove the paper roll and mandrel from the roll paper holder (Figure 4-1).
2. Check the paper low sensor bar for proper mechanical operation (Figure 4-5). The bar is spring-loaded and should swing toward the rear of the terminal when the paper roll is removed.
3. Turn the power ON/OFF switch located at the rear of the terminal to the ON position.
4. Check to see if the POWER/FAULT light is flashing.

##### NOTE

If the POWER/FAULT light is not flashing, before replacing switch verify that the the Paper Fault feature is set to paper low detection (refer to Chapter 5 for more detail. Be sure to clear the "cover open" fault after closing the access cover.

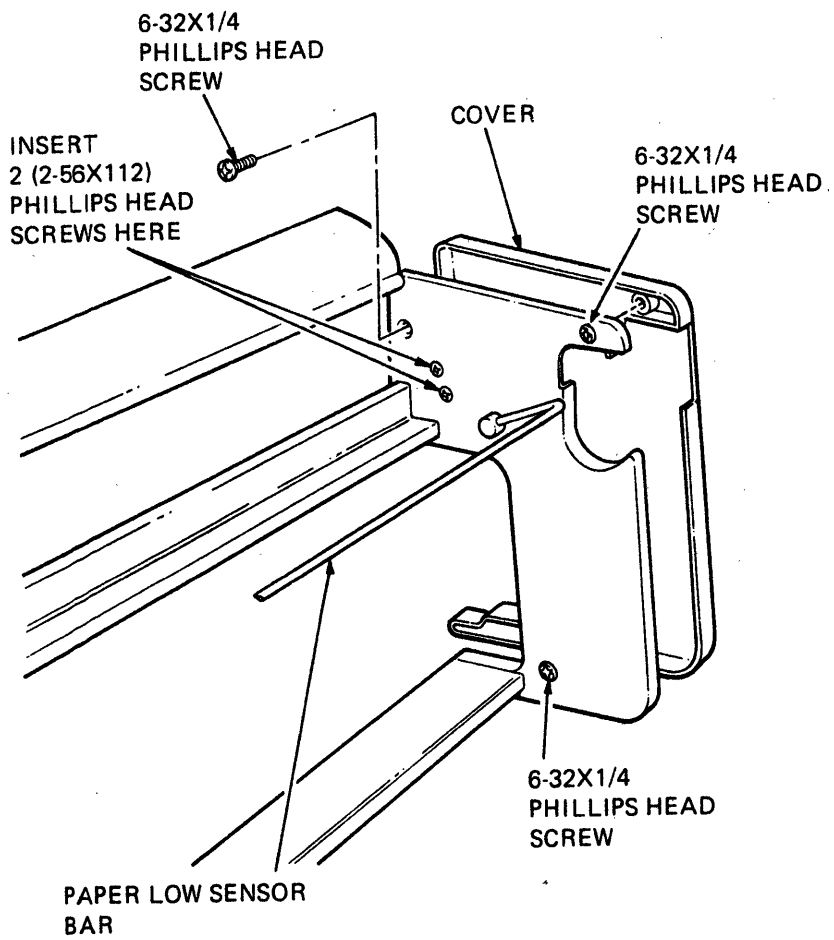

Figure 4-5 Roll Paper Holder Cover Removal

#### 4.4.2 Paper Low Detection Option Replacement

The following procedures describe replacement of the paper low detection option.

##### Paper Low Switch Replacement

1. Turn the power ON/OFF switch off and disconnect the ac power cord from the wall receptacle and then the terminal.
2. Pull the paper low plug out of the jack at the rear of the terminal.
3. Remove the paper and roll paper holder option.
4. Using a #1 Phillips head screwdriver, remove the three (6-32 X 1/4) Phillips head screws that secure the right roll paper cover (as viewed from the back) to the roll paper holder, and set the cover aside (Figure 4-5).
5. Disengage the paper low cable from the roll paper holder cover (Figure 4-6). Note the cable routing for use during replacement.
6. Remove the two tinnerman nuts securing the paper low switch to the roll paper holder cover (Figure 4-6).
7. Press down on the paper low sensor bar to open the cam (Figure 4-6).
8. Slide the paper low switch off its mounting screws (Figure 4-6). Note that the switch contact faces the cam.
9. Release the paper low sensor bar.
10. Remove the two (2-56 X 1/2) flat head Phillips screws from the inner side of roll paper holder (Figure 4-5).
11. To install a new paper low switch, perform steps 1 through 10 in reverse.

##### NOTE

To replace the paper low jack cable, refer to Paragraph 2.20 in Chapter 2.

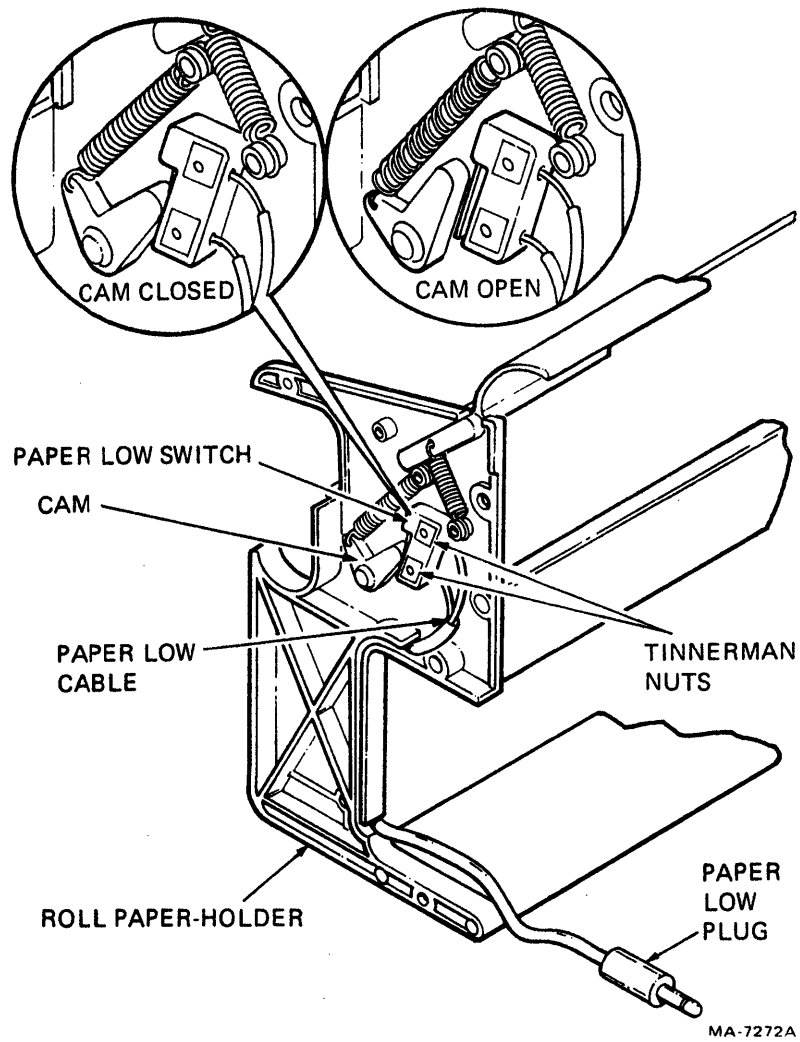

Figure 4-6 Paper Low Switch Removal



## 4.5 LAX34-CL 20 mA Current Loop Interface Option

### 4.5.1 Checkout Procedure

Perform the data loopback test described in the Testing and Troubleshooting Chapter (Chapter 1) to check out the 20 mA current loop interface option.

### 4.5.2 20 mA Current Loop Interface Option Replacement

The following procedures describe replacement of the 20 mA current loop interface option.

1. Turn the power ON/OFF switch located on the rear of the terminal to the OFF position and disconnect the ac line cord from the wall receptacle and then the terminal.
2. Remove the paper, and if installed, the roll paper holder or tractor options.
3. Perform the printer housing cover removal procedure (Paragraph 2.3).
4. Perform the keyboard/operator control panel bezel removal procedure (Paragraph 2.8).
5. Remove the logic board safety cover (Figure 4-7).
6. Disconnect the shield wire on the 20 mA cable from the left side plate (Figure 4-8).
7. Detach the mounting plug from the rear insert by removing the two (6-32) slotted hex-head screws (Figure 4-9).
8. Detach the 20 mA cable connector from the mounting plug by removing the two (6-32) slotted hex-head screws (Figure 4-9): Pass the connector through the circular cutout in the rear insert (Figure 4-9).
9. Disconnect P1 of the internal 20 mA adaptor cable from the 20 mA circuit board (Figure 4-10).
10. Disconnect P2 of the internal 20 mA adaptor cable from J7 on the logic (control) board (Figure 4-10). Slide the cable out from under the boards.

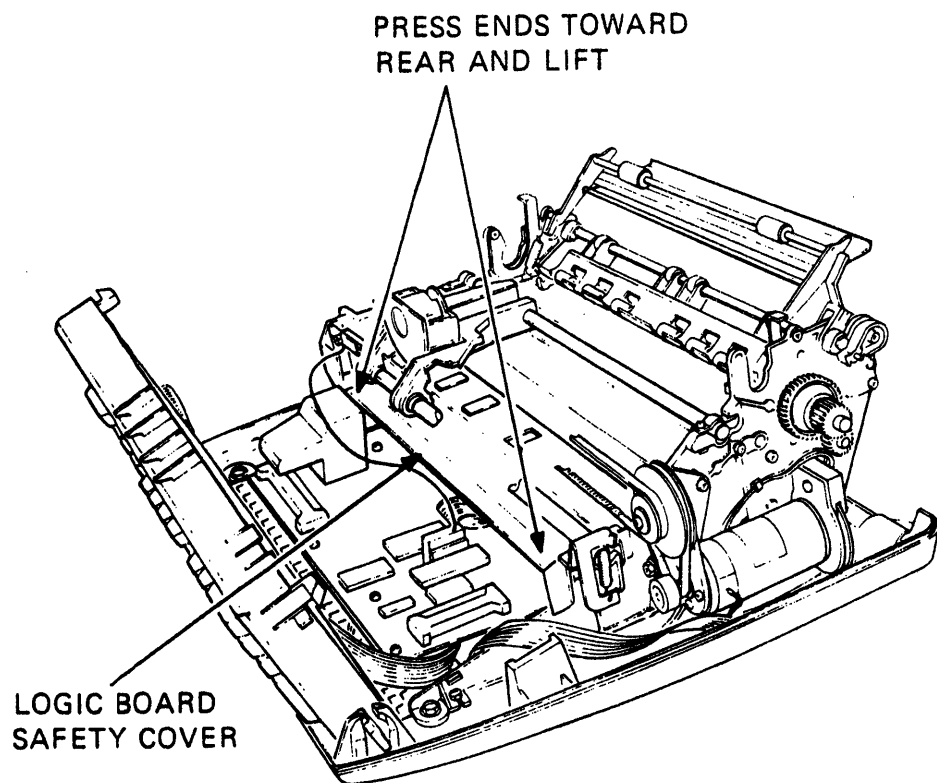

MA-8971

Figure 4-7 Logic Board Safety Cover Removal

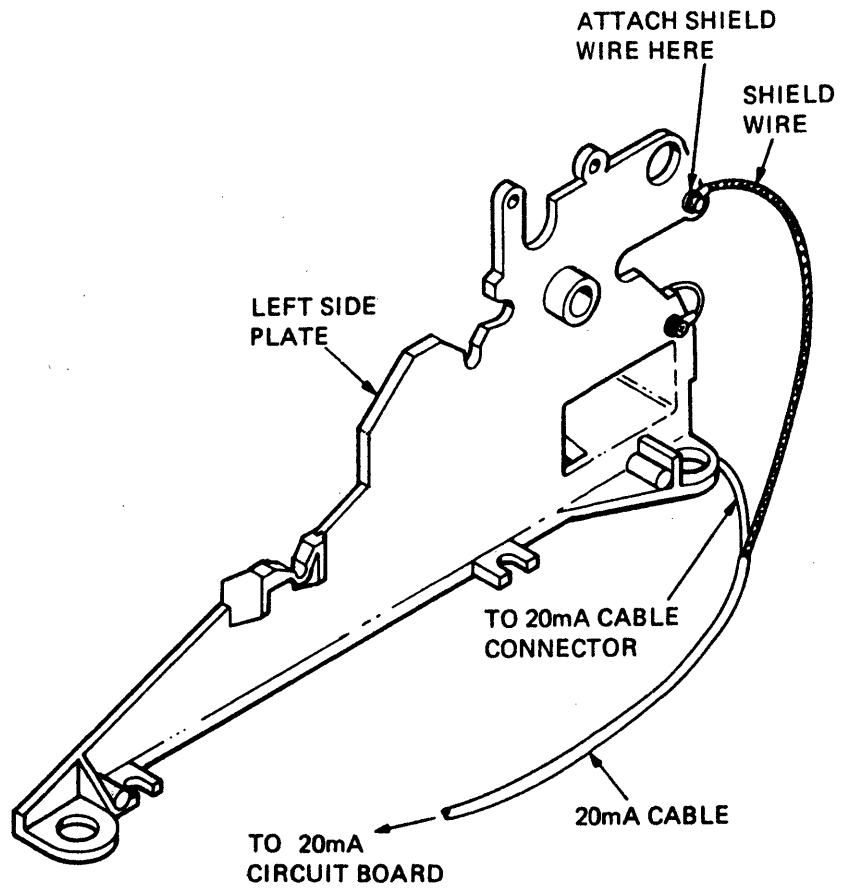
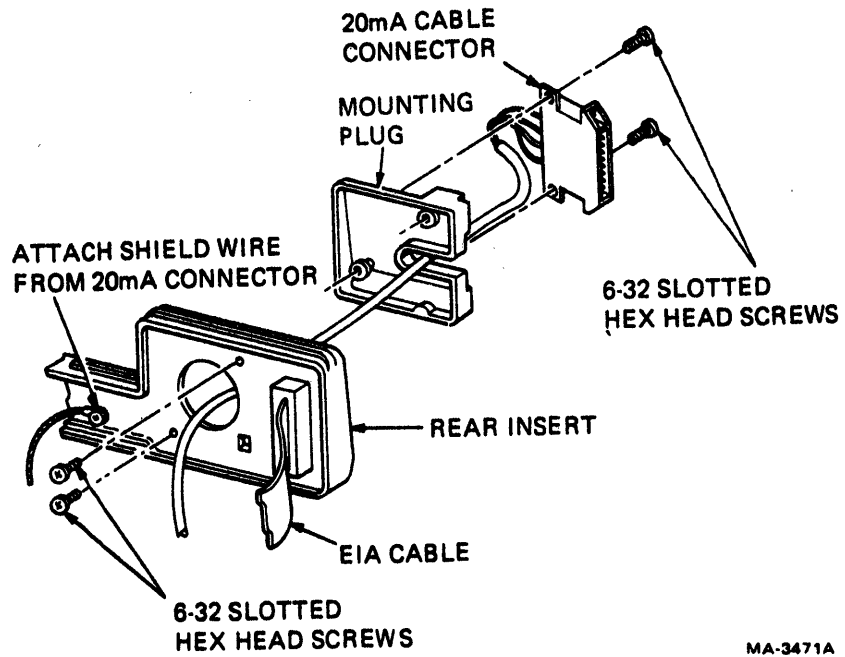
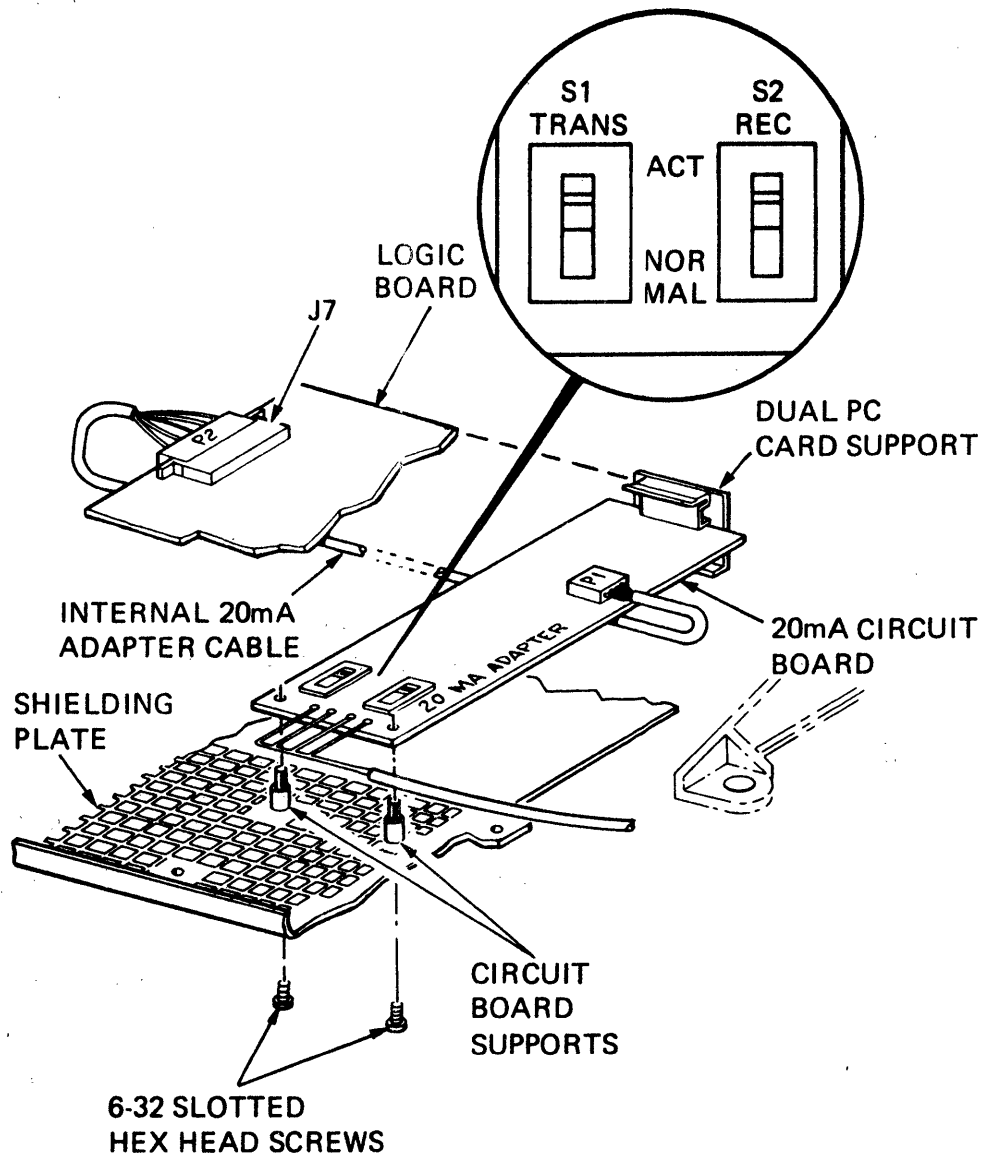

Figure 4-8 Detaching Shield Wire



MA-3471A

Figure 4-9 20 mA Cable Connector Removal



MA-3472B

Figure 4-10 20 mA Circuit Board Removal

11. Remove the 20 mA circuit board off the circuit board supports (Figure 4-10).
12. Carefully pull the board out of the slot in the dual PC card support and remove the complete assembly from the terminal (Figure 4-10).
13. To install a new 20 mA circuit board, perform the reverse of steps 1 through 12.
18. Set the TRANS and REC switches to the NORMAL position (Figure 4-10). If the terminal is to provide current to either the receive or transmit line, set the corresponding switch to ACT.

#### 4.6 LAX34-KL Numeric Keypad Option

##### 4.6.1 Checkout Procedure

To check out operation of the numeric keypad, enable local echo and press each key on the keypad. Observe that the proper character is printed.

##### 4.6.2 Numeric Keypad Option Replacement

The following procedure describes replacement of the numeric keypad option.

1. Turn the power ON/OFF switch located on the rear of the terminal to the OFF position and disconnect the ac line cord from the wall receptacle and then the terminal.
2. Remove the paper, and if installed, the roll paper holder or tractor options.
3. Perform the printer housing cover removal procedure (Paragraph 2.3).
4. Perform the keyboard/operator control panel bezel removal procedure (Paragraph 2.8)
5. Turn the keyboard bezel assembly upside down and place on a piece of foam or bubble plastic (Figure 4-11).
6. Remove the five 6-32 screws that secure the keyboard to the bezel (Figure 4-11).
7. Disconnect the numeric keypad connector at J2 on the keyboard (Figure 4-11).
8. Carefully snap the numeric keyboard out of the bezel (Figure 4-11).
14. To install a new numeric keypad, perform the reverse of steps 1 through 8. Be sure to route the new cable as shown in Figure 4-11.

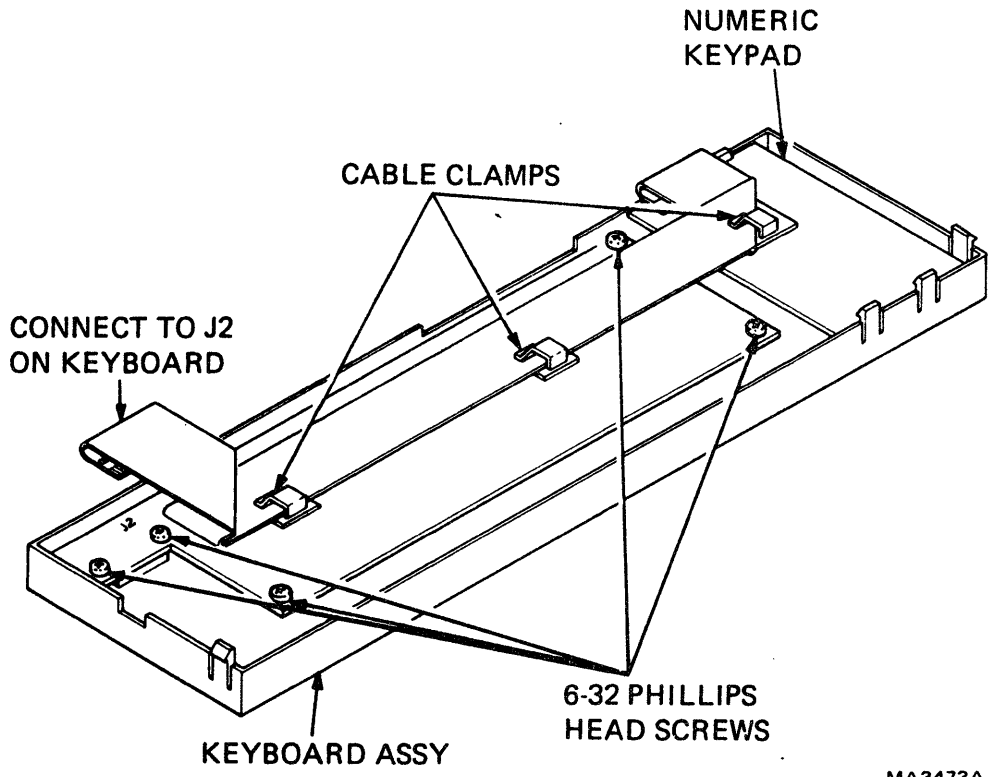

MA3473A

Figure 4-11 Numeric Keypad Removal





5  
OPERATING FEATURES SUMMARIES

5.1 GENERAL

This chapter summarizes the operating features of the Letterprinter and Letterwriter 100 terminals and the procedures used to enable or diable these features.

The operator selectable features are divided into 3 categories:

SET-UP Features (Letterwriter 100 only)	Paragraph 5.2
Switch Selectable Features (Letterprinter 100 only)	Paragraph 5.3
Jumper Selctable Features (Letterprinter and Letterwriter 100) Paragraph 5.4	Paragraph 5.4

5.2 SET-UP Features

The SET-UP features are selected from the keyboard when the terminal is in SET-UP mode. Table 5-1 lists and describes the Letterwriter 100 SET-UP features.

After changing the logic board be sure to reset the SET-UP features. Then print the status message to check that the desired features are selected.

Table 5-1 Letterwriter 100 SET-UP Feature Summary

SET-UP Feature	Keys Used To Change Feature	Function
<b>Operator Preference Features</b>		
Last character view	CTRL and VIEW	Terminal switches between auto and manual last character view.
Keyclick	Q = A RETURN Q = B RETURN	Keyclick is on Keyclick is off
<b>Form Features</b>		
Pitch mode	B = A RETURN B = B RETURN	Selects all pitch mode Selects font pitch mode
Horizontal pitch	H RETURN  H = A RETURN H = B RETURN H = C RETURN H = D RETURN H = E RETURN H = F RETURN H = G RETURN H = H RETURN	Prints out the horizontal pitch status information Selects 10 char/in Selects 12 char/in Selects 13.2 char/in Selects 16.5 char/in Selects 5 char/in Selects 6 char/in Selects 6.6 char/in Selects 8.25 char/in
Horizontal Margins	5 6 7	Sets the left margin at the current column Sets the right margin at the current column Clears both the left and right margins
Horizontal Tabs	1 2 3	Sets a horizontal tab stop at the current column Clears the horizontal tab stops at the current column Clears all horizontal tab stops
Vertical pitch	V RETURN  V = A RETURN V = B RETURN V = C RETURN V = D RETURN V = E RETURN V = F RETURN	Prints out the vertical pitch status information Selects 6 lines/in Selects 8 lines/in Selects 12 lines/in Selects 2 lines/in Selects 3 lines/in Selects 4 lines/in

Table 5-1 Letterwriter 100 SET-UP Feature Summary (Cont)

SET-UP Feature	Keys Used To Change Feature	Function
Form Length	F RETURN F = No. of inches	Prints current form length Sets form length at desired no. of inches
Top of Form	4	TOF is set at current position
Vertical Margins	(hold) SHIFT 5 (hold) SHIFT 6 (hold) SHIFT 7	Sets the top margin Sets the bottom margin Clears both the top and bottom margins
Vertical Tabs	(hold) SHIFT 1 (hold) SHIFT 2 (hold) SHIFT 3	Sets a vertical tab stop Clears the vertical tab stop Clears all vertical tab stops
<b>Communication Compatibility Features</b>		
Parity and Data Bits	P RETURN P = A RETURN P = B RETURN P = C RETURN P = D RETURN P = E RETURN P = F RETURN	Prints selections and current setting Selects no parity, 7 data bits, 8th bit set to mark Selects even parity, 7 data bits Selects no parity, 7 data bits, 8th bit set to space Selects odd parity, 7 data bits Selects even parity, 8 data bits Selects odd parity, 8 data bits
Receiver Error Processing	R RETURN R = A RETURN R = B RETURN	Prints selections and current setting Print substitute when error occurs Print characters as received

**Table 5-1 Letterwriter 100 SET-UP Feature Summary (Cont)**

SET-UP Feature	Keys Used To Change Feature	Function
Baud Rate	S RETURN	Prints selections and current setting
	S = A RETURN	50 baud
	S = B RETURN	75 baud
	S = C RETURN	110 baud
	S = D RETURN	134.5 baud
	S = E RETURN	150 baud
	S = F RETURN	200 baud
	S = G RETURN	300 baud
	S = H RETURN	600 baud
	S = I RETURN	1200 baud
	S = J RETURN	1800 baud
	S = K RETURN	2400 baud
	S = L RETURN	4800 baud
	S = M RETURN	7200 baud
	S = N RETURN	9600 baud
	S = O RETURN	75 baud send/600 baud receive
	S = P RETURN	75 baud send/1200 baud receive
S = Q RETURN	150 baud send/600 baud receive	
S = R RETURN	150 baud send/1200 baud receive	
S = S RETURN	300 baud send/2400 baud receive	
S = T RETURN	300 baud send/4800 baud receive	
S = U RETURN	600 baud send/2400 baud receive	
S = V RETURN	600 baud send/4800 baud receive	
Modem Control	Z RETURN	Prints selections and current setting
	Z = A RETURN	No modem control, restraint mode
	Z = B RETURN	No modem control, speed control mode
	Z = C RETURN	Modem control, restraint mode
	Z = D RETURN	Modem control, speed control mode
Paper Fault	O RETURN	Prints selections and current setting
	O = A RETURN	Selects no action (XOFF sent if enabled)
	O = B RETURN	Selects send break signal
	O = C RETURN	Selects disconnect
	O = D RETURN	Selects do not answer
Coded Disconnect	N RETURN	Prints selections and current setting
	N = A RETURN	Selects no disconnect (ignore EOT)
	N = B RETURN	Selects disconnect upon receipt of EOT

Table 5-1 Letterwriter 100 SET-UP Feature Summary (Cont)

SET-UP Feature	Keys Used To Change Feature	Function
Local Echo	E RETURN	Prints selections and current setting
	E = A RETURN	Selects no local echo
	E = B RETURN	Selects local echo
Auto XON/XOFF	X RETURN	Prints selections and current setting
	X = A RETURN	Selects no auto XON/XOFF
	X = B RETURN	Selects auto XON/XOFF
Answerback Message	M = delimiter message delimiter	Use up to 30 characters for message
Auto Answerback	A RETURN	Prints selections and current setting
	A = A RETURN	Selects auto answerback off
	A = B RETURN	Selects auto answerback on
End of Line Control	J RETURN	Prints selections and current setting
	J = A RETURN	Selects no end of line control
	J = B RETURN	Selects end of line control
Printer New Line	W RETURN	Prints selections and current setting
	W = A RETURN	Selects no new line
	W = B RETURN	Selects linefeed new line
	W = C RETURN	Selects carriage return new line
Printer Character Set	C RETURN	Prints G0 selections and current setting
	C = B RETURN	Selects USASCII as G0
	C = A RETURN	Selects United Kingdom as G0
	C = 9 RETURN	Selects French-Canada as G0
	C = K RETURN	Selects Germany as G0
	C = 7 RETURN	Selects Sweden as G0
	C = R RETURN	Selects France as G0
	C = 5 RETURN	Selects Finland as G0
	C = 6 RETURN	Selects Norway/Denmark as G0
	C = 0 RETURN	Selects VT100 Line Drawing Set as G0
	C = Y RETURN	Selects Italy as G0
C = Z RETURN	Selects Spain as G0	

Table 5-1 Letterwriter 100 SET-UP Feature Summary (Cont)

SET-UP Feature	Keys Used To Change Feature	Function
	D RETURN	Prints G1 selections and current setting
	D = B RETURN	Selects USASCII as G1
	D = A RETURN	Selects United Kingdom as G1
	D = 9 RETURN	Selects French-Canada as G1
	D = K RETURN	Selects Germany as G1
	D = 7 RETURN	Selects Sweden as G1
	D = R RETURN	Selects France as G1
	D = 5 RETURN	Selects Finland as G1
	D = 6 RETURN	Selects Norway/Denmark as G1
	D = 0 RETURN	Selects VT100 Line Drawing Set as G1
	D = Y RETURN	Selects Italy as G1
	D = Z RETURN	Selects Spain as G1
Break Key	U RETURN	Prints selections and current setting
	U = A RETURN	Selects break key on
	U = B RETURN	Selects break key off
Alternate Keypad	Y RETURN	Prints selections and current setting
	Y = A RETURN	Selects alternate keypad off
	Y = B RETURN	Selects alternate keypad on
Auto Linefeed	L RETURN	Prints selections and current setting
	L = A RETURN	Selects auto linefeed off
	L = B RETURN	Selects auto linefeed on
Keyboard Layout	K RETURN	Prints selections and current setting
	K = A RETURN	United States (ASCII)
	K = B RETURN	United Kingdom
	K = C RETURN	French Canada
	K = D RETURN	Germany
	K = E RETURN	Sweden
	K = F RETURN	France
	K = G RETURN	Finland
	K = H RETURN	Norway and Denmark

**Table 5-1 Letterwriter 100 SET-UP Feature Summary (Cont)**

SET-UP Feature	Keys Used To Change Feature	Function
Self-test	T RETURN	Prints character pattern test
	T and any printable character	Prints selected character continuously
	T (hold) SHIFT \	Prints out a pattern of asterisks in six passes per line
	T SPACEBAR	Carriage moves from right to left, back to the right, line feeds then repeats
	T \	Starts Loopback test 1
	T (hold) SHIFT /	Starts Loopback test 2
		<b>NOTE</b> Self-test ends when any character is typed on the keyboard.
Status	8	Prints current features in operating memory
Store	(hold) SHIFT 9	Stores features from operating memory in user permanent memory
Recall	9	Recalls features from user permanent memory in operating memory
Recall Default Settings	I RETURN	Resets the features stored in operating memory to default memory settings

### 5.3 Switch Selectable Features

The Letterprinter 100 terminals use internal switches to select the operator features (see Figure 5-1 for location). Table 5-2 lists and describes the Letterprinter 100 switch selectable features.

There are three different switches used in the terminal; two types of rocker switches and one slide switch (Figure 5-2). Identify the type switch on the terminal before changing any of the communication features.

To select a feature when a rocker switch is used, press down on the side of the switch that corresponds to the desired selection. To select a feature when a slide switch is used, push the switch tab to the side that corresponds to the desired selection.

#### CAUTION

Always use a small slotted screwdriver, scribe (or equivalent) to change a communication feature. Never use a lead pencil. Broken lead can cause a short on the printed circuit board.

After changing the logic board be sure to set the switches on the new board to the switch configuration on the removed logic board. Then print the status message to check that the desired features are selected.

### 5.4 Jumper Selectable Features

The Letterprinter 100 terminals use 3 jumpers (2 for Letterwriter 100) on the logic board to select terminal features (Figure 5-3). Table 5-3 lists the jumper selectable features and their functions.

#### NOTE

Both terminals also use jumpers to disable some of the communication signals. Refer to Chapter 3 for more detail.

To change a jumper selected feature, refer to the Chapter 3. After changing the logic board be sure that the jumper configuration on the new board matches the jumper configuration on the removed logic board. Then print the status message to check that the desired features are selected.

#### CAUTION

Make sure to remove the entire jumper. Any metal piece remaining may disturb the electronic operation of the terminal.



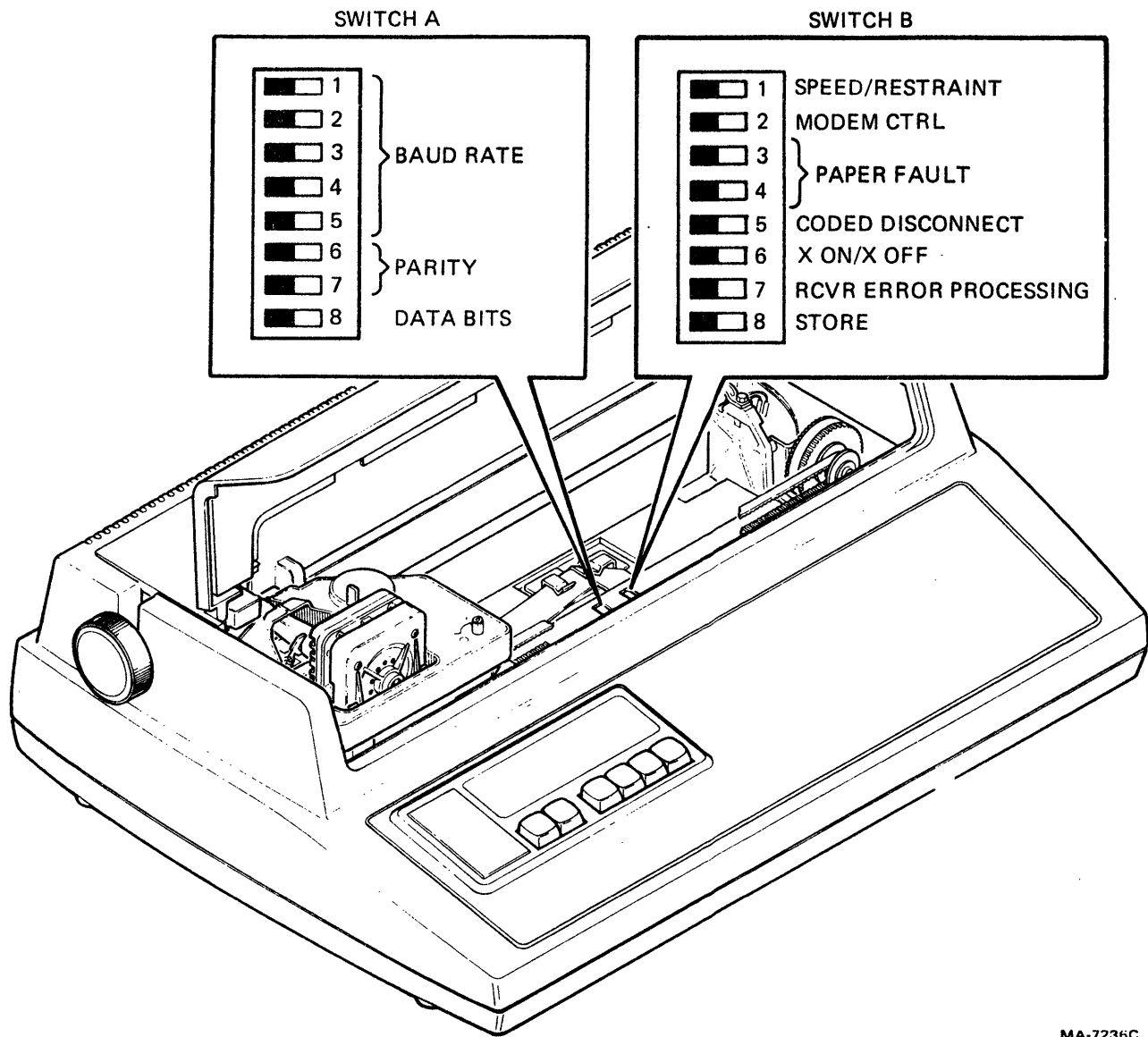

MA-7236C

Figure 5-1 Communication Switches

**Table 5-2 Letterprinter 100 Switch Selectable Feature Summary**

**Switch A**

**Baud Rate**

Switch Settings					Functions
1	2	3	4	5	
R	R	R	R	R	Selects 50 baud
L	R	R	R	R	Selects 75 baud
R	L	R	R	R	Selects 110 baud
L	L	R	R	R	Selects 134.5 baud
R	R	L	R	R	Selects 150 baud
L	R	L	R	R	Selects 200 baud
R	L	L	R	R	Selects 300 baud
L	L	L	R	R	Selects 600 baud
R	R	R	L	R	Selects 1200 baud
L	R	R	L	R	Selects 1800 baud
R	L	R	L	R	Selects 2400 baud
L	L	R	L	R	Selects 4800 baud
R	R	L	L	R	Selects 7200 baud
L	R	L	L	R	Selects 9600 baud
R	R	R	R	L	Selects 75 xmit./600 rec.
L	R	R	R	L	Selects 75 xmit./1200 rec.
R	L	R	R	L	Selects 150 xmit./600 rec.
L	L	R	R	L	Selects 150 xmit./1200 rec.
R	R	L	R	L	Selects 300 xmit./2400 rec.
L	R	L	R	L	Selects 300 xmit./4800 rec.
R	L	L	R	L	Selects 600 xmit./2400 rec.
L	L	L	R	L	Selects 600 xmit./4800 rec.
R	L	L	R	L	Selects 1800 xmit./600 rec.
L	L	L	R	L	Selects xmit./600 rec.

**Parity**

Switch Settings		Functions
6	7	
R	R	Selects space condition, no parity
L	R	Selects mark condition, no parity
R	L	Selects even parity
L	L	Selects odd parity

**Table 5-2 Letterprinter 100 Switch Selectable Feature Summary (Cont)**

**Data Bits**

Switch  
Settings  
8

**Functions**

R Selects 7 data bits per character  
L Selects 8 data bits per character

**Switch B**

**Speed Control/Restraint**

Switch  
Settings  
1

**Functions**

R Selects restraint mode  
L Selects speed control mode

**Modem Control**

Switch  
Settings  
2

**Functions**

R Selects no modem control  
L Selects modem control

**Paper Fault**

Switch  
Settings  
3 4

**Functions**

R R Selects no action (XOFF is sent if enabled)  
L R Selects sends break signal  
R L Selects disconnect (Drop DTR)  
L L Selects do not connect

**Coded Disconnect**

Switch  
Settings  
5

**Functions**

R Selects no disconnect (ignore EOT)  
L Selects disconnect upon receipt of EOT

**Table 5-2 Letterprinter 100 Switch Selectable Feature Summary (Cont)**

---

**Auto XON/XOFF**

<b>Switch Settings</b>	<b>Functions</b>
----------------------------	------------------

6

---

R	Selects no auto XON/XOFF
---	--------------------------

L	Selects auto XON/XOFF
---	-----------------------

**Receiver Error Processing**

<b>Switch Settings</b>	<b>Functions</b>
----------------------------	------------------

7

R	Selects print substitute character in
---	---------------------------------------

place of error	
----------------	--

L	Selects print characters as received
---	--------------------------------------

**Store**

<b>Switch Settings</b>	<b>Functions</b>
----------------------------	------------------

8

Move switch from right to left	Stores features from operating memory to user permanent memory
-----------------------------------	---

---

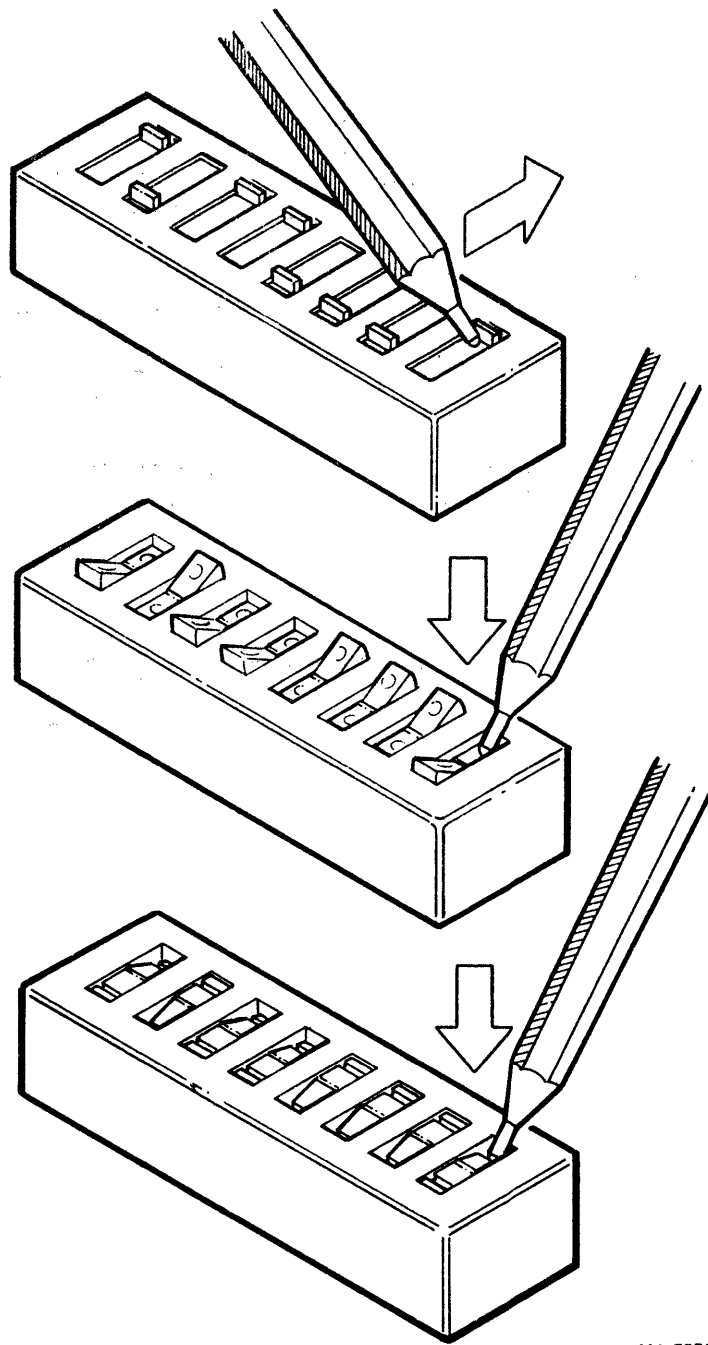

MA-7256

Figure 5-2 Communication Switch Types

Table 5-3 Jumper Selectable features

Jumper State	Functions
<b>Answerback message protect</b>	
Installed	Answerback message unprotected (message can be erased or changed)
Removed	Answerback message protected (message can not be erased or changed)
<b>Busy signal polarity</b>	
	<b>Terminal State    Busy Signal</b>
Installed	Busy            not asserted (0)
	Ready           asserted (1)
Removed	Busy            asserted (1)
	Ready           not asserted (0)
<b>Auto Answerback Letterprinter only</b>	
Installed	Auto answerback disabled
Removed	Auto answerback enabled

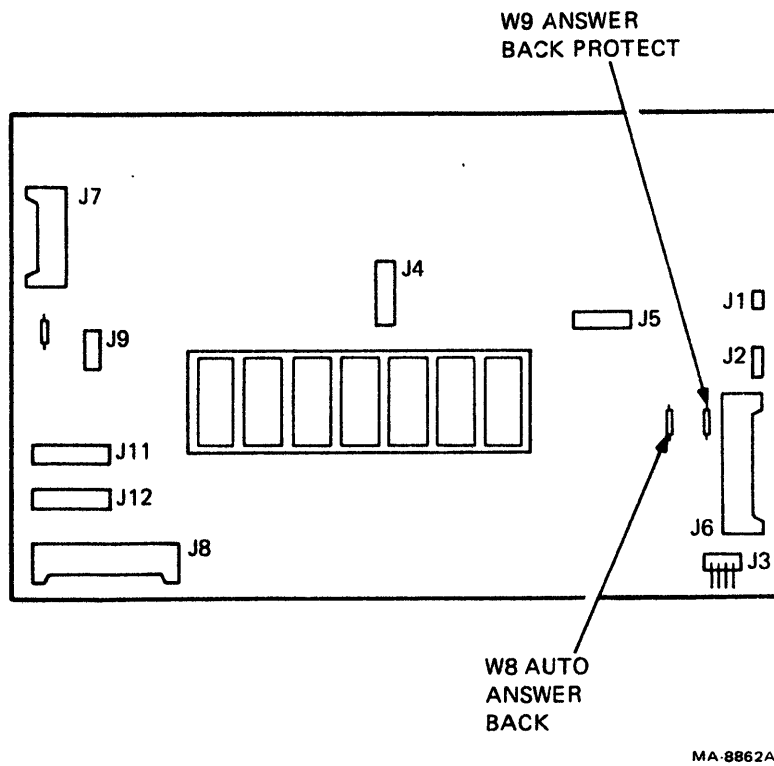

Figure 5-3 Jumper Selectable Features





## 6 RECOMMENDED SPARE PARTS LISTS

### 6.1 GENERAL

This chapter contains recommended spare parts lists for all of the LA100 series terminals and the available options. It also includes a list of terminal microcode revisions.

Most of the mechanical assemblies and electromechanical assemblies are common to all LA100 terminals. Electromechanical assemblies unique to particular terminals are identified within the spare parts list.

Table 6-1 lists the spares list for the LA100 terminals. Table 6-2 lists the LA100 options spares list.

**Table 6-1 Recommended Terminal Spares List**

Description	Part Number
Power Supply	H7837
4 amp fuse	90-07219-02
Ribbon cartridge	70-17462-00
Ribbon drive cable	12-15348-00
Paper release lever	74-22986-00
Paper release cam	74-22987-00
Paper drive cluster gear	70-18600-00
Timing belt	12-15362-00
Belt spring clip	74-25865-00
Line feed motor	12-17474-00
Keyboard w/o bezel (Letterprinter)	70-17886-01
Keyboard w/o bezel (Letterwriter)	70-17863-00
Legend strip (Letterprinter)	36-17590-00
Legend strip (Letterwriter)	36-15450-02
Keycap set (Letterprinter)	12-14333-VE
Keyboard (Letterwriter)	12-17800-65
Keyswitch filler plug	74-25601-00
Logic board	54-14256-00
PC card rear support	12-15395-00
PC card standoffs	74-23971-00
Logic board screws (5)	90-06453-00
Logic board safety cover	70-17876-00
Logic/power cable	70-18388-2L
EIA cable assembly	70-18977-2L
Printhead	70-18409-00
Printhead adjustment lever	70-18639-00
Printhead retaining lever	74-25720-00
Printhead cable assembly	70-17874-00
Printhead extension spring (2)	N/A
Platen assembly	70-15727-02
Platen knob	12-15315-01
Friction assembly	70-15733-01
Carriage assembly	70-17859-00
Front carriage shaft	12-15315-00
Rear carriage shaft	12-15315-01
Right carriage shaft clamp (3)	74-26410-01
Left carriage shaft clamp (3)	74-26410-02
Idler/pulley assembly	70-15735-01
Interlock switch assembly	70-17628-00
Servo motor/encoder assembly	70-18707-00
Bail bar assembly	70-15738-00
Torsion spring	12-15561-00
Clutch/hub assembly	70-15742
Paper out switch	LAX34-PL
EIA loopback connector	12-15336-01
Mylar cross member assembly	70-17346-00
Orator 10 EPROM	23-073E4-00

**Table 6-1 Recommended Terminal Spares List (Cont)**

Description	Part Number
Orator 10 ROM	23-049E4-00
Courier 10 Overlay EPROM	23-074E4-00
Courier 10 Overlay ROM	23-051E4-00
Orator 10 ROM cartridge	LA10X-AD
Courier 10 Overlay ROM cartridge	LA10X-BA
Power Cord (120V)	

**Table 6-2 Recommended Option Spares List**

Description	Part Number
<b>OPTION</b>	
Roll paper holder option	LAX34-RL
Paper low option	LAX34-LL
Tractor option	LAX34-AL
Printer stand	LAX34-SL
20mA Current loop option	LAX34-CL
Numeric keypad option	LAX34-KL
Multiple font option	LA10X-FL
<b>RECOMMENDED SPARES</b>	
Tractor option	70-16260-00
LAX34-CL CL option	70-16645-25
Cable, Internal, 20 mA	70-16647-1K
Loop Cable, 20 mA Loop	70-16646-1L
Numeric keypad option	70-16653-00
Paper low switch	LAX34-LL
Holder, paper assembly	70-15728-00

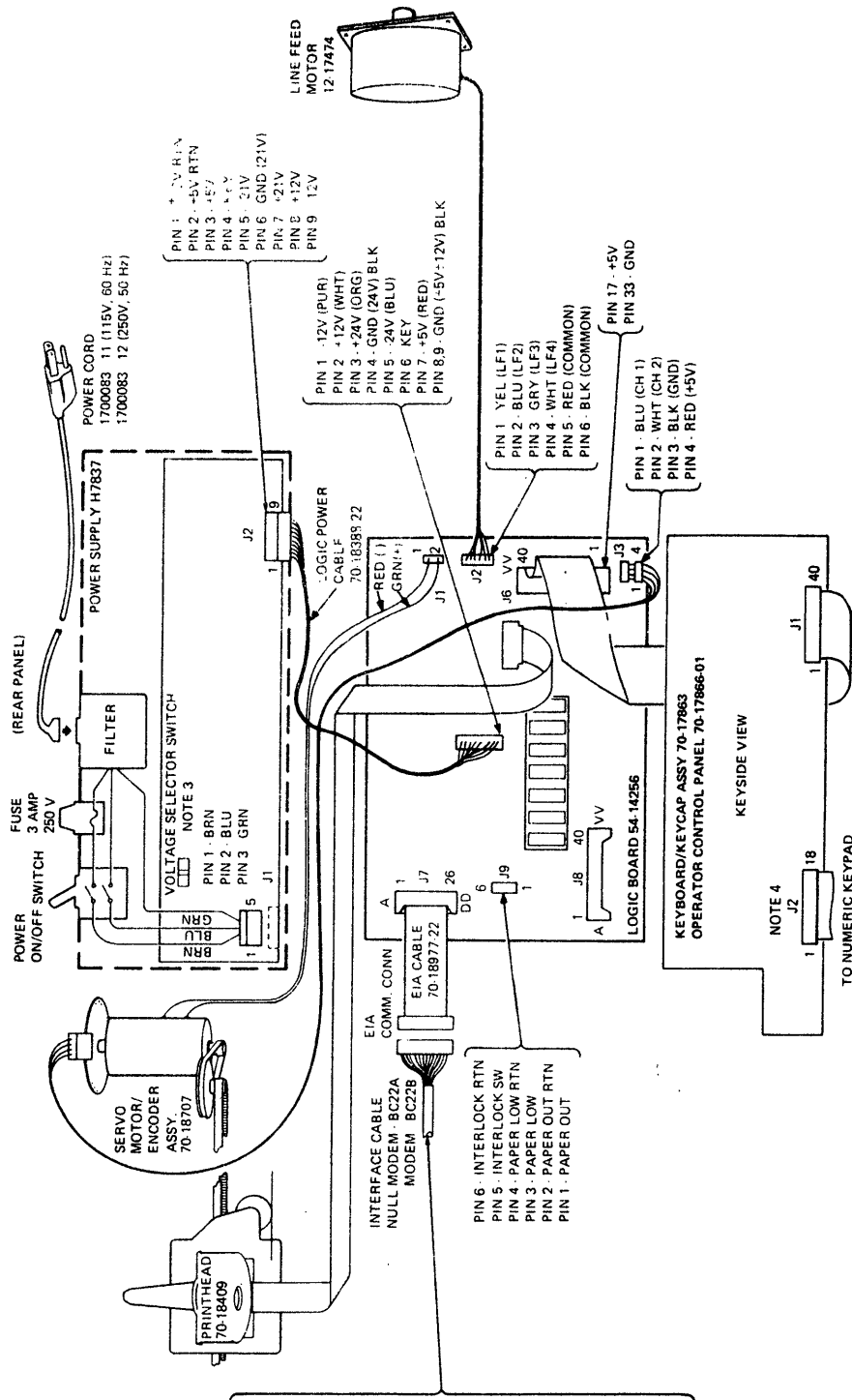

- PIN NUMBER
- 1 PROTECTIVE GROUND (JUMPER)
  - 2 TRANSMITTED DATA (TXD)
  - 3 RECEIVED DATA (RXD)
  - 4 REQUEST TO SEND (RTS)
  - 5 CLEAR TO SEND (CTS)
  - 6 DATA SET READY (DSR)
  - 7 SIGNAL GROUND (COMMON RETURN)
  - 8 RECEIVE LINE SIGNAL DETECT
  - 9 NOT USED
  - 10 BUSY (JUMPER)
  - 11 SPEED INDICATOR (JUMPER)
  - 12 NOT USED (CTS-TTC)\*
  - 13 NOT USED (+12V)\*
  - 14 NOT USED
  - 15 NOT USED (-12V)\*
  - 16 NOT USED
  - 17 NOT USED (TXD-TRI)\*
  - 18 SEC. REQUEST TO SEND (JUMPER)
  - 19 DATA TERMINAL READY (DTR)
  - 20 NOT USED (CD-TTL)\*
  - 21 NOT USED
  - 22 SPEED SELECT (JUMPER)
  - 23 NOT USED
  - 24 NOT USED (DTR-TRI)\*
  - 25
- \* SIGNALS IN PARENTHESES ARE PRESENT ON SOME EARLY PRODUCTION BOARDS.

NOTE: LETTERWRITER MODELS ONLY

### Physical Functional Block Diagram





