

Maintenance Service Guide

**Models 6236/6237**

# **DISK DRIVE SUBSYSTEM**

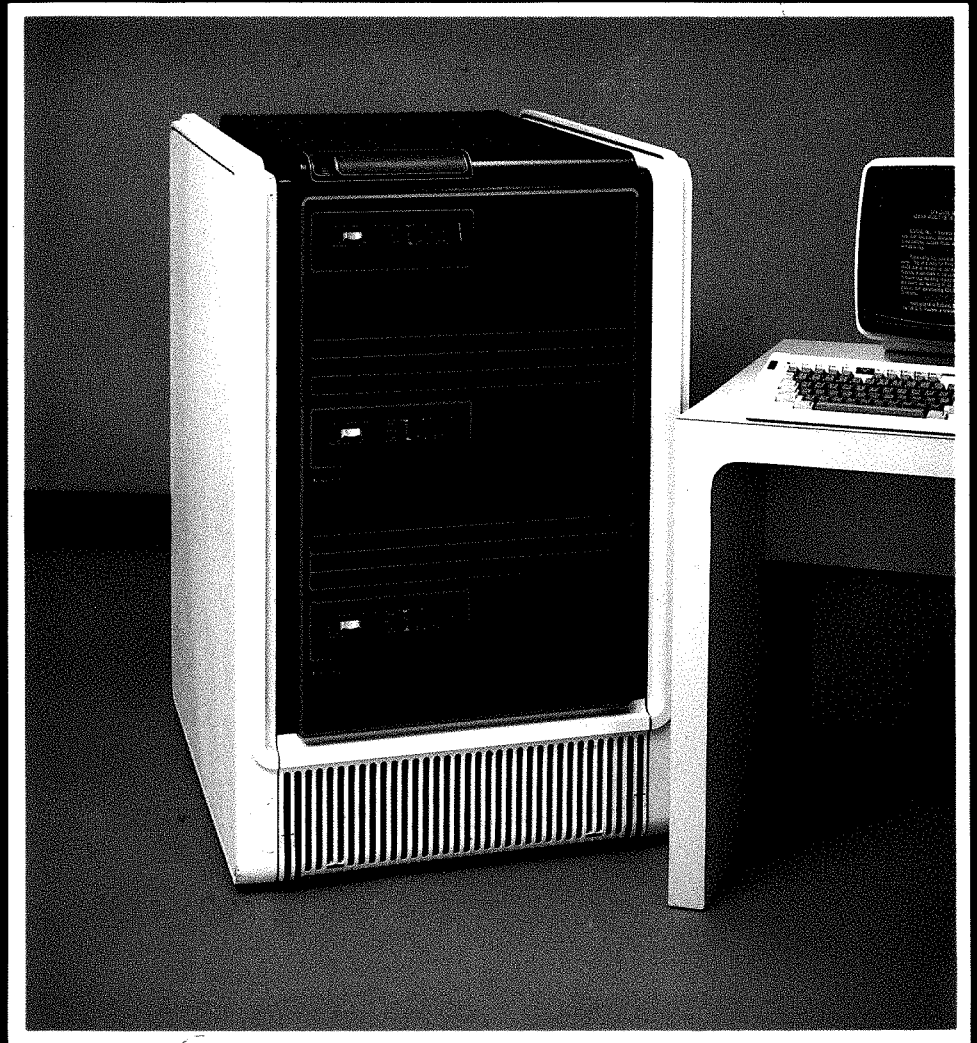

Data General Service, Inc.  
A Subsidiary of Data General Corporation

MAINTENANCE  
SERVICE GUIDE  
FOR  
MODELS 6236/6237  
DISK DRIVE SUBSYSTEM

Prepared by

Data General Service, Inc.  
A Subsidiary of Data General Corporation  
Westborough, MA 01580

## NOTICE

Data General Corporation (DGC) has prepared this document for use by DGC personnel and customers as a guide to the proper installation, operation, and maintenance of DGC equipment and software. The drawings and specifications contained herein are the property of DGC and shall neither be reproduced in whole or in part without DGC prior written approval nor be implied to grant any license to make, use, or sell equipment manufactured in accordance herewith.

DGC reserves the right to make changes in specifications and other information contained in this document without prior notice, and the reader should in all cases consult DGC to determine whether any such changes have been made.

THE TERMS AND CONDITIONS GOVERNING THE SALE OF DGC HARDWARE PRODUCTS AND THE LICENSING OF DGC SOFTWARE CONSIST SOLELY OF THOSE SET FORTH IN THE WRITTEN CONTRACTS BETWEEN DGC AND ITS CUSTOMERS. NO REPRESENTATION OR OTHER AFFIRMATION OF FACT CONTAINED IN THIS DOCUMENT INCLUDING BUT NOT LIMITED TO STATEMENTS REGARDING CAPACITY, RESPONSE-TIME PERFORMANCE, SUITABILITY FOR USE OR PERFORMANCE OF PRODUCTS DESCRIBED HEREIN SHALL BE DEEMED TO BE A WARRANTY BY DGC FOR ANY PURPOSE, OR GIVE RISE TO ANY LIABILITY OF DGC WHATSOEVER.

IN NO EVENT SHALL DGC BE LIABLE FOR ANY INCIDENTAL, INDIRECT, SPECIAL OR CONSEQUENTIAL DAMAGES WHATSOEVER (INCLUDING BUT NOT LIMITED TO LOST PROFITS) ARISING OUT OF OR RELATED TO THIS DOCUMENT OR THE INFORMATION CONTAINED IN IT, EVEN IF DGC HAS BEEN ADVISED, KNEW OR SHOULD HAVE KNOWN THE POSSIBILITY OF SUCH DAMAGES.

ECLIPSE<sup>®</sup>, ECLIPSE MV/4000<sup>®</sup>, ECLIPSE MV/6000<sup>®</sup>, ECLIPSE MV/8000<sup>®</sup>, and ECLIPSE MV/8000 II<sup>®</sup> computers are U.S. registered trademarks of Data General Corporation. microECLIPSE<sup>™</sup> and ECLIPSE MV/10000<sup>™</sup> computers are trademarks of Data General Corporation, Westborough, Massachusetts.

Ordering No. 015-000137-00

Copyright © Data General Corporation, 1983  
All Rights Reserved  
Printed in the United States of America  
August, 1983

Data General Corporation (DGC) has prepared this manual for use by DGC personnel and customers as a guide to the proper installation, operation, and maintenance of DGC equipment and software. The drawings and specifications contained herein are the property of DGC and shall neither be reproduced in whole or in part without DGC's prior written approval nor be implied to grant any license to make, use, or sell equipment manufactured in accordance herewith.

### RECORD OF REVISIONS

DATE	REV	CHANGE NUMBER	NOTES/PAGES AFFECTED	APPROVAL
08/83	00	00	Maintenance Service Guide for Models 6236/6237 Disk Drive Subsystem, First Release	

## TABLE OF CONTENTS

SECTION	TITLE	PAGE
1.	INTRODUCTION	1-1
1.1	DESCRIPTION OF MODELS . . . . .	1-1
1.2	PERFORMANCE SPECIFICATIONS . . . . .	1-4
1.3	FIELD REPLACEABLE UNITS . . . . .	1-5
1.4	DISK DRIVE SUBSYSTEM DESCRIPTION . . . . .	1-12
1.4.1	Printed Circuit Boards . . . . .	1-12
1.4.2	Controller PCB . . . . .	1-13
1.4.3	Head Disk Assembly . . . . .	1-13
1.4.4	Power Supply Assembly . . . . .	1-13
1.4.5	Coarse Air Filter . . . . .	1-14
1.4.6	Switch Assembly (Model 6237 only) . . . . .	1-14
1.4.7	Latch Assembly (Model 6237 only) . . . . .	1-14
1.4.8	Power Package (Model 6237 only) . . . . .	1-14
2.	OPERATING CONTROLS AND PROCEDURES	2-1
2.1	CONTROL SWITCHES AND INDICATOR LEDES . . . . .	2-1
2.1.1	External Switches . . . . .	2-1
2.1.2	Circuit Breakers . . . . .	2-4
2.1.3	Internal Switches . . . . .	2-6
2.1.4	Indicator LEDES . . . . .	2-15
2.2	OPERATING PROCEDURES . . . . .	2-19
2.2.1	Power-Up Procedure . . . . .	2-20
2.2.2	Power-Down Procedure . . . . .	2-23
2.2.3	Monitoring Procedure . . . . .	2-23
2.2.4	Emergency Conditions . . . . .	2-23
2.3	OPERATOR MAINTENANCE . . . . .	2-27
3.	THEORY OF OPERATION	3-1
3.1	ARCHITECTURAL THEORY . . . . .	3-1
3.1.1	Disk Function PCBs . . . . .	3-3
3.1.2	Head Disk Assembly (HDA) . . . . .	3-3
3.1.3	Front Panel PCB . . . . .	3-7
3.1.4	Power . . . . .	3-10
3.1.5	Cabling . . . . .	3-15
3.2	FUNCTIONAL THEORY . . . . .	3-19
3.2.1	Controller PCB . . . . .	3-19
3.2.2	Disk Function PCBs . . . . .	3-23
3.3	OPERATIONAL THEORY . . . . .	3-31
3.3.1	Power-Up Sequence (Including Power-Up Diagnostics) . . . . .	3-31
3.3.2	P10 Commands to/from 6236 Controller PCB . . . . .	3-33

## TABLE OF CONTENTS (Continued)

SECTION	TITLE	PAGE
3.3.3	The Control Block . . . . .	3-34
3.3.4	Seek Operation . . . . .	3-35
3.3.5	Write Operation . . . . .	3-36
3.3.6	Read Operation . . . . .	3-37
3.3.7	Recalibrate Operation . . . . .	3-38
4.	FAULT DIAGNOSIS . . . . .	4-1
4.1	TROUBLESHOOTING REFERENCE INFORMATION . . . . .	4-1
4.2	INITIAL TROUBLESHOOTING CHECKOUT . . . . .	4-15
4.2.1	Initial Checkout . . . . .	4-15
4.2.2	Gaining Access to the Drive . . . . .	4-16
4.3	TROUBLESHOOTING FLOWCHARTS . . . . .	4-19
4.4	DIAGNOSTIC TROUBLESHOOTING PROGRAMS . . . . .	4-29
4.4.1	The 6236 Diagnostic Program - 6236 DIAG . . . . .	4-30
4.4.2	Function Verification Diagnostic - 6236 FUNC . . . . .	4-38
4.4.3	UDKP RELI and UDKV RELI Reliability Programs . . . . .	4-43
4.4.4	6236 FMTR (Formatter) Program . . . . .	4-59
5.	REMOVAL AND REPLACEMENT PROCEDURES	5-1
5.1	TOOLS AND EQUIPMENT . . . . .	5-3
5.2	CONTROLLER PCB REMOVAL/REPLACEMENT . . . . .	5-3
5.3	FRONT PANEL REMOVAL/REPLACEMENT . . . . .	5-6
5.4	OPENING AND CLOSING THE DRIVE . . . . .	5-7
5.5	COARSE AIR FILTER REMOVAL/REPLACEMENT . . . . .	5-10
5.6	FRONT PANEL PCB REMOVAL/REPLACEMENT . . . . .	5-11
5.7	READ/WRITE PCB REMOVAL/REPLACEMENT . . . . .	5-13
5.8	POSITION CONTROL PCB REMOVAL/REPLACEMENT . . . . .	5-15
5.9	CONTROL LOGIC PCB REMOVAL/REPLACEMENT . . . . .	5-17
5.10	POWER AMPLIFIER PCB REMOVAL/REPLACEMENT . . . . .	5-19
5.11	SPINDLE CONTROL PCB REMOVAL/REPLACEMENT . . . . .	5-20
5.12	POWER CONTROL PCB REMOVAL/REPLACEMENT . . . . .	5-21
5.13	POWER SUPPLY ASSEMBLY REMOVAL/REPLACEMENT . . . . .	5-23
5.14	POWER SUPPLY STUNT PLUGS REMOVAL/REPLACEMENT . . . . .	5-27
5.15	AC CIRCUIT BREAKER REMOVAL/REPLACEMENT . . . . .	5-28
5.16	POWER SUPPLY FUSE (F1) REMOVAL/REPLACEMENT . . . . .	5-29
5.17	HEAD DISK ASSEMBLY (HDA) REMOVAL/REPLACEMENT . . . . .	5-30
5.18	TERMINATOR REMOVAL/REPLACEMENT . . . . .	5-36
5.19	AC POWER CORD REMOVAL/REPLACEMENT . . . . .	5-36
5.20	METER HIGH CABINET REMOVAL/REPLACEMENT PROCEDURES (MODEL 6237) . . . . .	5-37
5.20.1	Latch Assembly (Top and Rear) Removal/Replacement . . . . .	5-37
5.20.2	Switch Assembly Removal/Replacement . . . . .	5-38
5.20.3	Power Package Fuse Removal/Replacement . . . . .	5-41
5.20.4	Power Package AC Power Cord Removal/Replacement . . . . .	5-42
5.20.5	Power Package Removal/Replacement . . . . .	5-42
6.	INSTALLATION/REMOVAL	6-1
6.1	SITE PREPARATION REQUIREMENTS . . . . .	6-2
6.1.1	Physical Specifications . . . . .	6-2

## TABLE OF CONTENTS (Continued)

SECTION	TITLE	PAGE
6.1.2	Electrical Specifications . . . . .	6-4
6.1.3	Environmental Specifications . . . . .	6-5
6.2	TOOLS, EQUIPMENT AND MATERIALS . . . . .	6-6
6.3	UNPACKING, CHECKLIST AND INSPECTION . . . . .	6-6
6.3.1	Unpacking/Model 6236 . . . . .	6-6
6.3.2	Unpacking/Model 6237 . . . . .	6-8
6.3.3	Unpacking the Controller PCB . . . . .	6-12
6.3.4	Equipment Checklist and Initial Inspection . . . . .	6-12
6.4	6236/6237 INSTALLATION . . . . .	6-14
6.4.1	Controller PCB Jumpering and Installation . . . . .	6-16
6.4.2	Model 6236 Installation Procedure . . . . .	6-16
6.4.3	6237 Installation . . . . .	6-26
6.5	POWER-UP/DOWN PROCEDURES . . . . .	6-31
6.5.1	Power-Up Procedure . . . . .	6-31
6.5.2	Power-Down Procedure . . . . .	6-31
6.6	SUBSYSTEM VERIFICATION . . . . .	6-32
6.7	SUBSYSTEM REMOVAL . . . . .	6-32

## LIST OF ILLUSTRATIONS

FIGURE	TITLE	PAGE
1-1	6236 Disk Drive Subsystem . . . . .	1-2
1-2	6237 Disk Drive Subsystem . . . . .	1-3
1-3	FRU Locations (6236/6237) . . . . .	1-8
1-4	FRU Locations (6237 only) . . . . .	1-10
2-1	External Controls and Indicator LEDs . . . . .	2-2
2-2	External Control Switches (6237) . . . . .	2-3
2-3	Circuit Breaker (6236) . . . . .	2-4
2-4	Meter High Cabinet Circuit Breakers (6237) . . . . .	2-5
2-5	Unit and Diagnostic Switches . . . . .	2-7
2-6	Internal Switches and Indicator LEDs . . . . .	2-12
2-7	Gaining Access to the Drive . . . . .	2-14
2-8	Front Panel Digital Display Indicator - Error Code Listing . . . . .	2-25
2-9	Coarse Air Filter . . . . .	2-27
3-1	6236 Disk Subsystem Connected to a CPU . . . . .	3-1
3-2	6236 HDA and PCBs . . . . .	3-2
3-3	Drive Schematic Block Diagram . . . . .	3-4
3-4	Linear Motor Signal Chain . . . . .	3-5
3-5	R/W and Servo Heads . . . . .	3-6
3-6	Front Panel PCB . . . . .	3-7
3-7	Front Panel PCB Block Diagram . . . . .	3-8
3-8	Front Panel PCB Switch Selections . . . . .	3-10
3-9	DC Power Distribution . . . . .	3-11
3-10	Power Supply Assembly Block Diagram . . . . .	3-12
3-11	Power Control PCB Block Diagram . . . . .	3-14
3-12	6236 Interconnection Diagram . . . . .	3-17
3-13	6236 Controller PCB Block Diagram . . . . .	3-20
3-14	Controller to Disk Data Transfers . . . . .	3-22
3-15	6236 Disk Drive Major PCBs . . . . .	3-23
3-16	Drive Logic PCB Block Diagram . . . . .	3-25
3-17	R/W PCB Block Diagram . . . . .	3-27
3-18	Position Control PCB Block Diagram . . . . .	3-28
3-19	Power Amplifier PCB Block Diagram . . . . .	3-29
3-20	Spindle Control PCB Block Diagram . . . . .	3-30
3-21	Data Sector Format . . . . .	3-37
3-22	SERVO Surface Radial Format . . . . .	3-38
4-1	FRU and Connector Locations . . . . .	4-3
4-2	6236/6237 Interconnection Diagram . . . . .	4-5
4-3	6236/6237 Interconnection Signals . . . . .	4-7
4-4	LED, Fuse and Switch Locations . . . . .	4-11
4-5	Gaining Access to the Drive . . . . .	4-18
4-6	Master Flowchart . . . . .	4-20
4-7	AC Power Check . . . . .	4-21



## LIST OF ILLUSTRATIONS (Continued)

FIGURE	TITLE	PAGE
4-8	DC Power Check . . . . .	4-22
4-9	Power Control PCB Test Points . . . . .	4-25
4-10	Front Panel Digital Display Indicator - Error Code Listing . . . . .	4-27
5-1	Controller PCB . . . . .	5-4
5-2	Controller PCB Device Code Jumpering . . . . .	5-5
5-3	Front Panel Removal and Replacement . . . . .	5-7
5-4	Top Cover . . . . .	5-9
5-5	Coarse Air Filter . . . . .	5-10
5-6	Front Panel PCB . . . . .	5-12
5-7	Read/Write PCB . . . . .	5-14
5-8	Position Control PCB . . . . .	5-16
5-9	Control Logic PCB . . . . .	5-18
5-10	Power Amplifier PCB . . . . .	5-20
5-11	Spindle Control PCB . . . . .	5-21
5-12	Power Control PCB . . . . .	5-22
5-13	Power Supply (rear view) . . . . .	5-25
5-14	Power Supply (side view) . . . . .	5-26
5-15	Power Control PCB and Control Logic PCB . . . . .	5-26
5-16	AC Circuit Breaker . . . . .	5-29
5-17	Power Control PCB . . . . .	5-32
5-18	Drive Assembly (Front and Top Views) . . . . .	5-33
5-19	Spindle Control PCB and Power Control PCB . . . . .	5-34
5-20	HDA (with PCB Support Assembly removed) . . . . .	5-34
5-21	HDA (Front View) . . . . .	5-35
5-22	Terminator and AC Power Cord . . . . .	5-37
5-23	Latch Assembly . . . . .	5-39
5-24	Switch Assembly . . . . .	5-40
5-25	Fuse and AC Power Cord . . . . .	5-43
5-26	Power Package . . . . .	5-44
6-1	6236 Disk Drive Dimensions . . . . .	6-3
6-2	6237 Disk Drive Dimensions . . . . .	6-3
6-3	6236/6237 Disk Drive Service Dimensions . . . . .	6-4
6-4	6236 Disk Drive Unpacking . . . . .	6-7
6-5	Anti-tip Bar Installation . . . . .	6-8
6-6	6237 Disk Drive Unpacking . . . . .	6-9
6-7	6237 Disk Drive Removal . . . . .	6-10
6-8	Meter High Cabinet Anti-tip Bars . . . . .	6-11
6-9	Controller PCB Packaging . . . . .	6-12
6-10	Equipment Checklist . . . . .	6-13
6-11	Shipping Restraints . . . . .	6-15
6-12	Controller PCB Jumpering . . . . .	6-17
6-13	Rear Cover . . . . .	6-18
6-14	Power Supply Voltage Configuration . . . . .	6-19
6-15	Write Protect and Disable Switches . . . . .	6-20
6-16	Top Cover . . . . .	6-21
6-17	Front Panel Switches (SW1 to SW4) . . . . .	6-22
6-18	6236 Rack Mounting . . . . .	6-23
6-19	6236 I/O Cabling and AC Power Cord Connection . . . . .	6-24
6-20	6237 Rack Mounting . . . . .	6-28
6-21	6237 I/O Cabling and AC Power Cord Connection . . . . .	6-29
6-22	Circuit Breaker . . . . .	6-31

## LIST OF TABLES

TABLE	TITLE	PAGE
1-1	Model Numbers/Description . . . . .	1-2
1-2	Model 6236 Performance Specifications . . . . .	1-4
1-3	Field Replaceable Units . . . . .	1-5
2-1	External Switches . . . . .	2-2
2-2	Unit Switches SW1 and SW2 . . . . .	2-6
2-3	Diagnostic Switches SW3 and SW4 . . . . .	2-9
2-4	Pass/Seek Count . . . . .	2-11
2-5	Internal Switches . . . . .	2-14
2-6	External Indicator LEDs (Front Panel PCB) . . . . .	2-15
2-7	Power Control PCB LEDs . . . . .	2-18
2-8	Spindle Control PCB LEDs . . . . .	2-19
2-9	Power Amplifier PCB LED . . . . .	2-19
2-10	Power-Up Test Sequence . . . . .	2-21
2-11	Power-Up Sequence (ON-LINE Normal Operating Mode) . . . . .	2-22
4-1	Spindle Control PCB LEDs . . . . .	4-13
4-2	Power Amplifier PCB LED . . . . .	4-13
4-3	Power Control PCB LEDs . . . . .	4-14
4-4	Internal Switches . . . . .	4-15
4-5	Fuses . . . . .	4-15
4-6	6236/6237 Diagnostic Programs . . . . .	4-29
4-7	6236 DIAG Program Run Times . . . . .	4-31
4-8	Failing FRUs Indicated by the 6236 DIAG Program . . . . .	4-31
4-9	Switch Options . . . . .	4-32
4-10	Other Commands . . . . .	4-32
4-11	Internal Cell Opening Commands . . . . .	4-36
4-12	Other ODT Commands . . . . .	4-37
4-13	6236 FUNC Program Run Times . . . . .	4-38
4-14	Failing FRUs Indicated by the 6236 FUNC Program . . . . .	4-38
4-15	Switch Options . . . . .	4-39
4-16	Other Commands . . . . .	4-40
4-17	UDKP RELI Program Run Times . . . . .	4-44
4-18	UDKV RELI Program Run Times . . . . .	4-45
4-19	Data Patterns . . . . .	4-48
4-20	UDKP/UDKV RELI Command String . . . . .	4-48
4-21	Switch Options . . . . .	4-51
4-22	Other Commands . . . . .	4-52
4-23	UDKP/UDKV Starting Addresses . . . . .	4-53
4-24	Operator Controlled Printouts . . . . .	4-56
4-25	6236 FMTR Program Switch Options . . . . .	4-62
4-26	6236 FMTR Program - Other Commands . . . . .	4-63
4-27	FMTR Program Starting Address . . . . .	4-63
4-28	Operator Controlled Printouts . . . . .	4-65
5-1	Tools and Test Equipment . . . . .	5-3
6-1	Physical Specifications . . . . .	6-2
6-2	Electrical Specifications . . . . .	6-4
6-3	AC Power Cable Requirements . . . . .	6-5
6-4	Environmental Specifications . . . . .	6-5
6-5	Tools and Test Equipment . . . . .	6-6
6-6	Temperature Stabilization . . . . .	6-14

## SECTION 1

### INTRODUCTION

Data General's Model 6236 disk drive subsystem consists of a self-contained, random access, moving head, non-removable media disk drive, and a controller PCB. The Model 6237 disk drive consists of three 6236 disk drives installed in a stand-alone Meter High Cabinet. The controller contains all logic necessary to transfer data between four 6236 disk drives and main memory, via the Burst Multiplexor Channel Interface (BMCI). The controller PCB is CPU resident.

The 6236 disk drive has a formatted storage capacity of 354 Megabyte (MB) and the 6237 disk drive has a formatted storage capacity of 1.06 Gigabyte (GB). The 6236 drive records data on eight surfaces and the 6237 drive records data on 24 surfaces. Each data surface has two heads, 789 tracks and 56 sectors per track. There are 786 user tracks, one internal diagnostic track, one controller reserved track and one field service track.

The 6236 disk drive subsystem features:

- Single board controller interface
- Controller PCB supporting up to four 6236 disk drives per subsystem
- Fixed, sealed, non-removable media (Winchester technology design)
- No scheduled maintenance requirements
- Modular design to optimize serviceability to the FRUs in the drive
- Single phase power supply
- Enhanced (on board) diagnostic capability

#### 1.1 DESCRIPTION OF MODELS

Table 1-1 lists model numbers and voltage configurations. Figure 1-1 illustrates the 6236 disk drive subsystem and Figure 1-2 illustrates the 6237 disk drive subsystem.

**Table 1-1. Model Numbers/Description**

Model Number	Description
B/E-6236	354 MB Disk 120 V/60 Hz
B/E-6236-1	354 MB Disk 100 V/50 Hz
B/E-6236-2	354 MB Disk 220 V/50 Hz
B/E-6236-4	354 MB Disk 240 V/50 Hz
B/E-6236-5	354 MB Disk 100 V/60 Hz
B/E-6236-A	354 MB Disk 120 V/60 Hz (without Controller PCB)
B/E-6236-A1	354 MB Disk 100 V/50 Hz (without Controller PCB)
B/E-6236-A2	354 MB Disk 220 V/50 Hz (without Controller PCB)
B/E-6236-A4	354 MB Disk 240 V/50 Hz (without Controller PCB)
B/E-6236-A5	354 MB Disk 100 V/60 Hz (without Controller PCB)
E-6237-B	GB Box 120 V/60 Hz (w/120 V/60 Hz drives)
E-6237-B1	GB Box 120/240 V CT USA (w/100 V/50 Hz drives)
E-6237-B5	GB Box 120/240 V CT USA (w/100 V/60 Hz drives)
E-6237-C	GB Box 3 Phase, 120/208 V USA (w/120 V/60 Hz drives)
E-6237-D2	GB Box 3 Phase, 220/380 V, 240/415 V outside USA (w/220 V/50 Hz drives)
E-6237-D4	GB Box 3 Phase, 220/380 V, 240/415 V, outside USA (w/240 V/50 Hz drives)

B/E = Blue or Earthtone front panel

CT = Center Tap

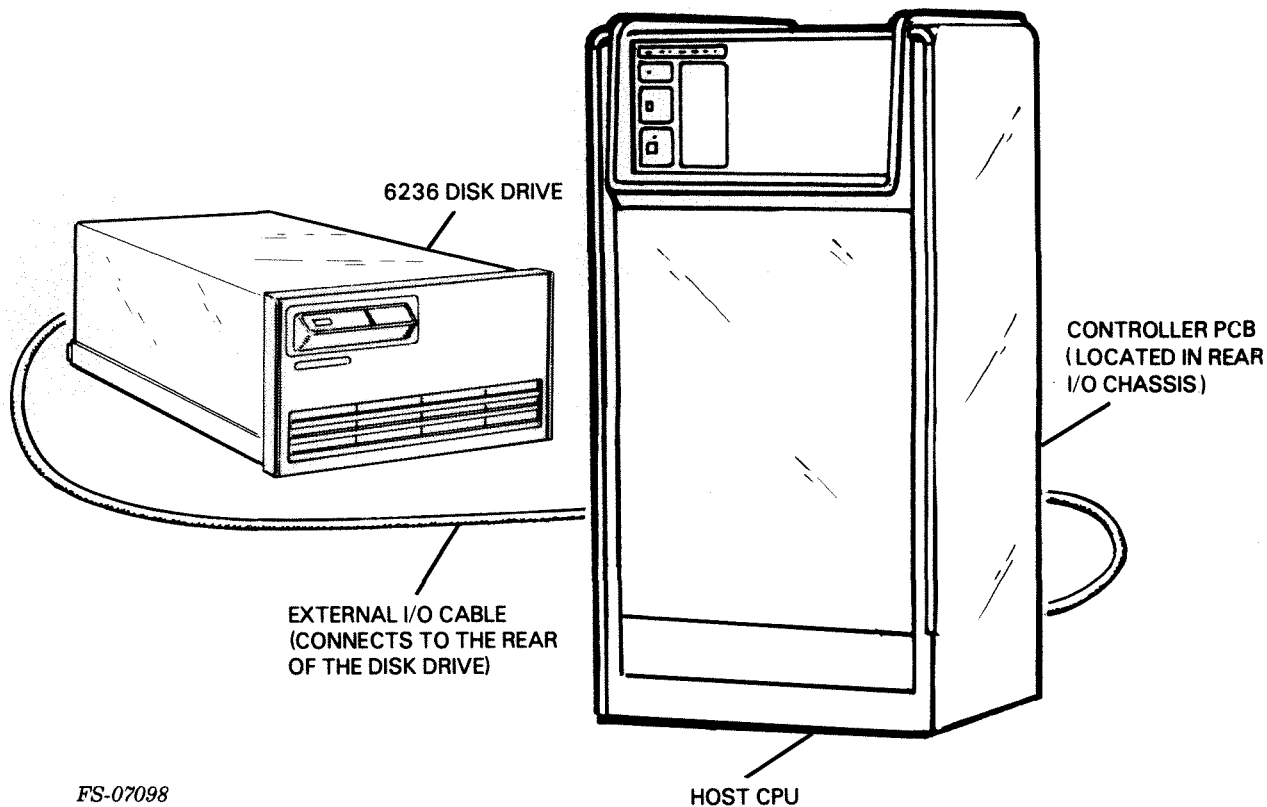

FS-07098

**Figure 1-1. 6236 Disk Drive Subsystem**

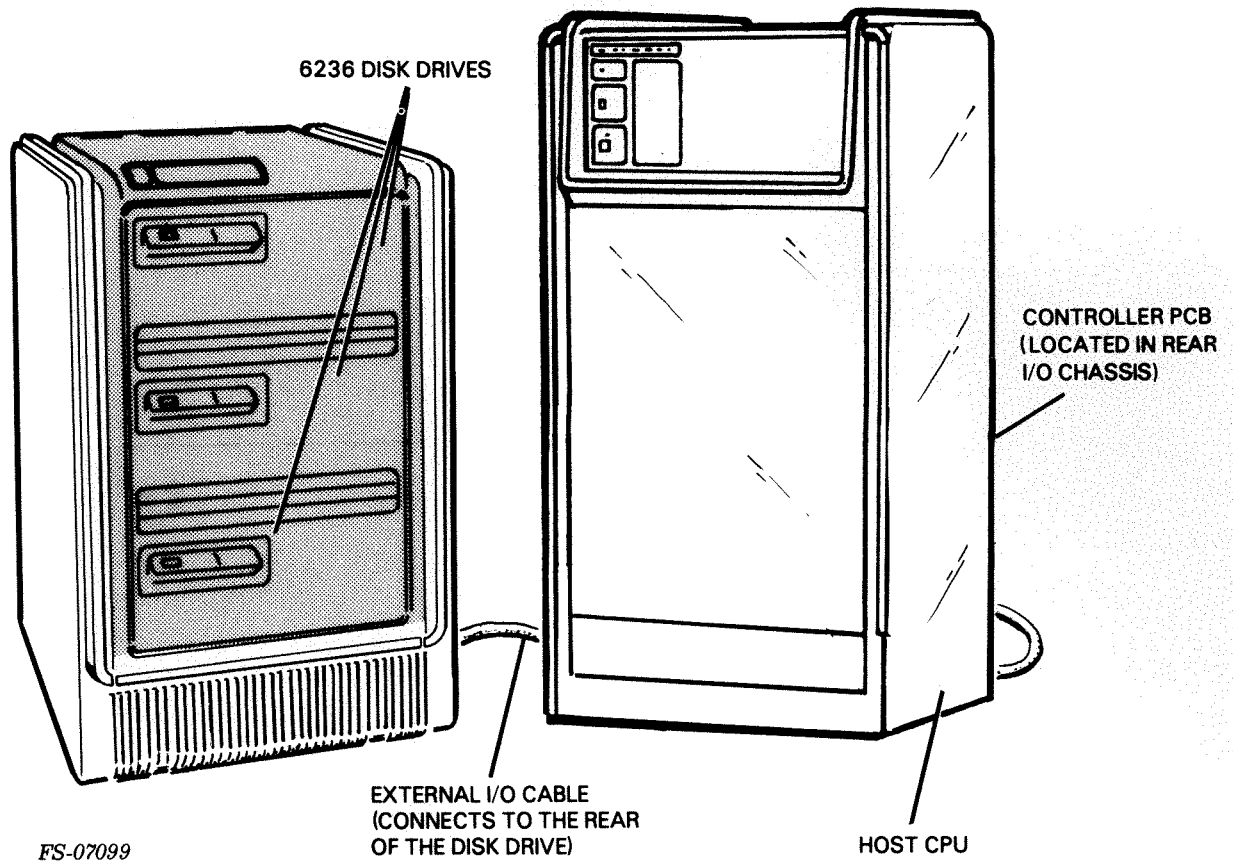

Figure 1-2. 6237 Disk Drive Subsystem

## 1.2 PERFORMANCE SPECIFICATIONS

Table 1-2 lists performance specifications for the 6236 disk drive subsystem. The 6237 disk drive subsystem consists of three independent 6236 disk drives.

Table 1-2. Model 6236 Performance Specifications (Sheet 1 of 2)

Description	Specification
Formatted Capacity	354 MB
Number of Disks (Platters)	5
Number of Data Surfaces	8
Platter Diameter	14 in
Data Heads	16
Servo Heads	1
Bits Per Inch (BPI)	10,438
Flux Changes per Inch (FCI)	7829
Tracks per Inch	714
Recording Code	2-8
Number of Sectors	56
Data Bytes/Sector	512
Capacity/Track	28.672 KByte
Capacity/Cylinder	458.752 Byte
Number of Cylinders	789
User	786
Internal Diagnostic	1
F.S. Diagnostic	1
Controller Reserved	1
Access Time	
Single Track	5 ms
Average (1/3 stroke)	20 ms
Maximum (full stroke)	35 ms
Seek Error Rate	<1 in 10 <sup>7</sup> seeks

**Table 1-2. Model 6236 Performance Specifications (Sheet 2 of 2)**

Description	Specification
Rotational Latency	10 ms
Rotational Speed	3000 rpm
Transfer Rate	1.68 MB/sec
Error Rate	
Recoverable	10 EXP (-10)
Nonrecoverable	10 EXP (-12)

### 1.3 FIELD REPLACEABLE UNITS

Table 1-3 lists the Field Replaceable Units (FRUs) contained in the 6236/6237 disk drive subsystem. Figure 1-3 illustrates the location of the major FRUs in the 6236/6237 subsystem. Figure 1-4 illustrates the location of the FRUs that are unique to the 6237 subsystem.

**Table 1-3. Field Replaceable Units (Sheet 1 of 3)**

Description	DGC Part Number
Controller PCB	005-14278
Head/Disk (Module) Assembly (HDA)	005-17820
Power Supply Assembly	005-17831
Read/Write PCB	005-18357
Control Logic PCB	005-18355
Position Control PCB	005-18359
Spindle Control PCB	005-18367
Power Amp (Servo Power) PCB	005-18369
Power Control PCB	005-18363
Front Panel PCB	005-18365
Front Panel Assembly (Earthtone)	005-17818
Front Panel Assembly (Blue)	005-19919

**Table 1-3. Field Replaceable Units (Sheet 2 of 3)**

Description	DGC Part Number
Coarse Air Filter	002-11044
I/O Cable Assembly	005-17825
External I/O Cable Assembly (S/280,MV/4000,MV/10000,MV/8000 II)	005-18480
External I/O Cable Assembly (S/250,C/350,M/600,MV/6000, MV/8000,S/140)	005-20298
External I/O Cable Assembly (S/280,MV/4000,MV/10000, MV/8000 II (30 feet)	005-20629
External I/O Cable Assembly (S/280,MV/4000,MV/10000, MV/8000 II (40 feet)	005-20630
External I/O Cable Assembly (S/250,C/350,M/600,MV/8000, S/140 (20 feet)	005-20631
External I/O Cable Assembly (S/250, C/350,M/600,MV/6000, MV/8000,S/140 (30 feet)	005-20632
External I/O Cable Assembly (S/250,C/350,M/600,MV/6000, MV/8000,S/140 (40 feet)	005-20633
External I/O Cable Assembly (S/280,MV/4000,MV/10000, MV/8000 II (20 feet)	005-21154
CPU Internal Cable Assembly (S/280,MV/4000,MV/10000,MV/8000 II)	005-20104
CPU Internal Cable Assembly (S/250,C/350,M/600,MV/6000, MV/8000,S/140)	005-20216
Daisy Chain Cable	005-20186
Terminator	005-20105
Ground Strap	005-08356
Circuit Breaker (220/240 V)	113-00299



**Table 1-3. Field Replaceable Units (Sheet 3 of 3)**

Description	DGC Part Number
Circuit Breaker (100/120 V)	113-00113
Frequency Stunt Plug	005-20121
Voltage Select Plug 240 V/50 Hz	005-20194
Voltage Select Plug 220 V/50 Hz	005-20195
Voltage Select Plug 120 V/60 Hz	005-20196
Voltage Select Plug 100 V/50 Hz	005-20197
Voltage Select Plug 100 V/60 Hz	005-20198
Power Cord 100-120 V	109-00719
Power Cord 220-240 V	109-00681
Fuse 10 A, 250 V	113-00002
Fuse 2 A, 250 V	113-00041
Fuse 6 A, 32 V	113-00117
Hardware Mounting Kit	005-17817
Front Panel Assembly (lower)*	005-20092
Power Cord Assembly* (3 phase Domestic)	005-14372
Power Cord Assembly* (2 phase Domestic)	005-14760
Packaging*	044-119
Latch Assembly*	005-17325
Switch Assembly*	005-18303
Power Package, 120/240 V, (center tapped) Domestic*	005-20093
Power Package (3 phase) 120/208 V, Domestic*	005-20094
Power Package (3 phase) 220/380 V, 240/415 V, Export*	005-20095

\* Model 6237 only

Data General Corporation (DGC) has prepared this manual for use by DGC personnel and customers as a guide to the proper installation, operation, and maintenance of DGC equipment and software. The drawings and specifications contained herein are the property of DGC and shall neither be reproduced in whole or in part without DGC's prior written approval nor be implied to grant any license to make, use, or sell equipment manufactured in accordance herewith.

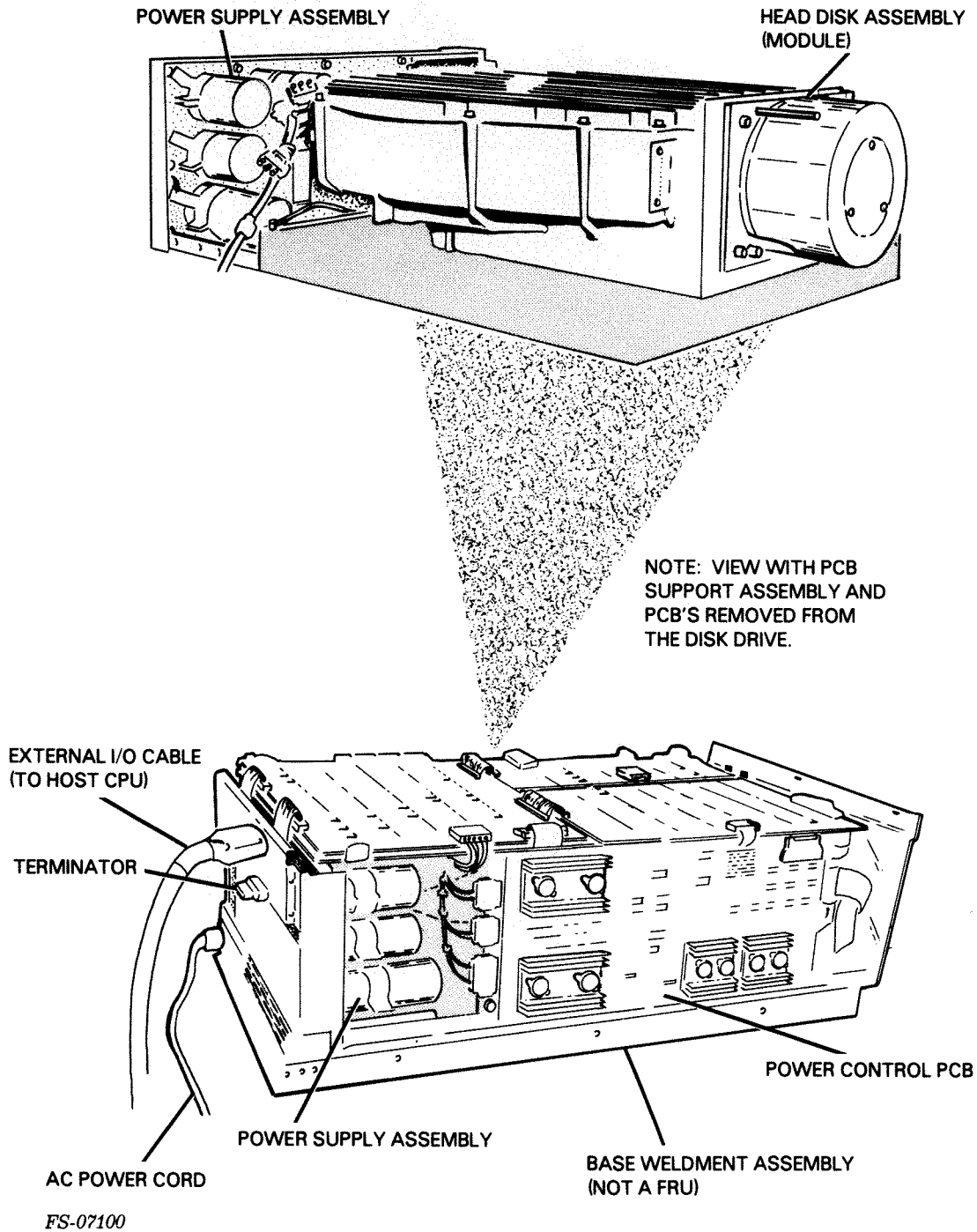
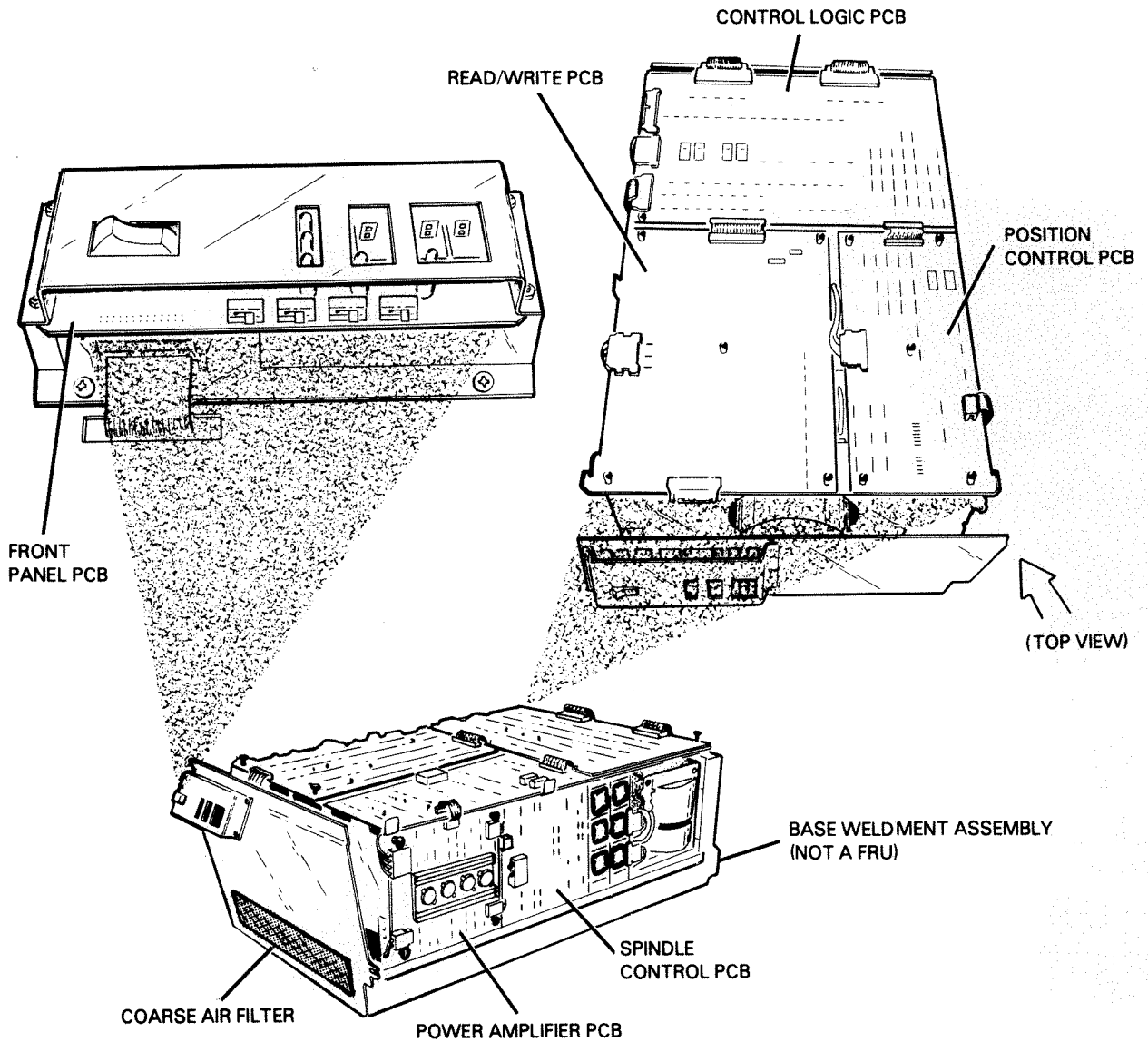

Figure 1-3. FRU Locations (6236/6237) (Sheet 1 of 2)

Data General Corporation (DGC) has prepared this manual for use by DGC personnel and customers as a guide to the proper installation, operation, and maintenance of DGC equipment and software. The drawings and specifications contained herein are the property of DGC and shall neither be reproduced in whole or in part without DGC's prior written approval nor be implied to grant any license to make, use, or sell equipment manufactured in accordance herewith.



FS-07101

Figure 1-3. FRU Locations (6236/6237) (Sheet 2 of 2)

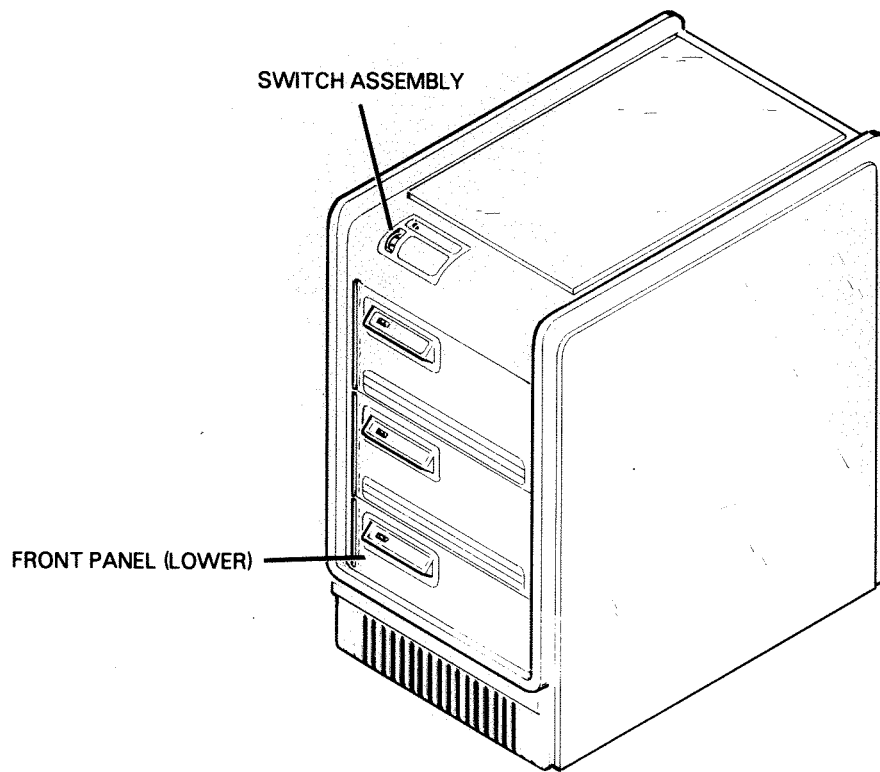

FS-07102

**Figure 1-4.** FRU Locations (6237 only) (Sheet 1 of 2)

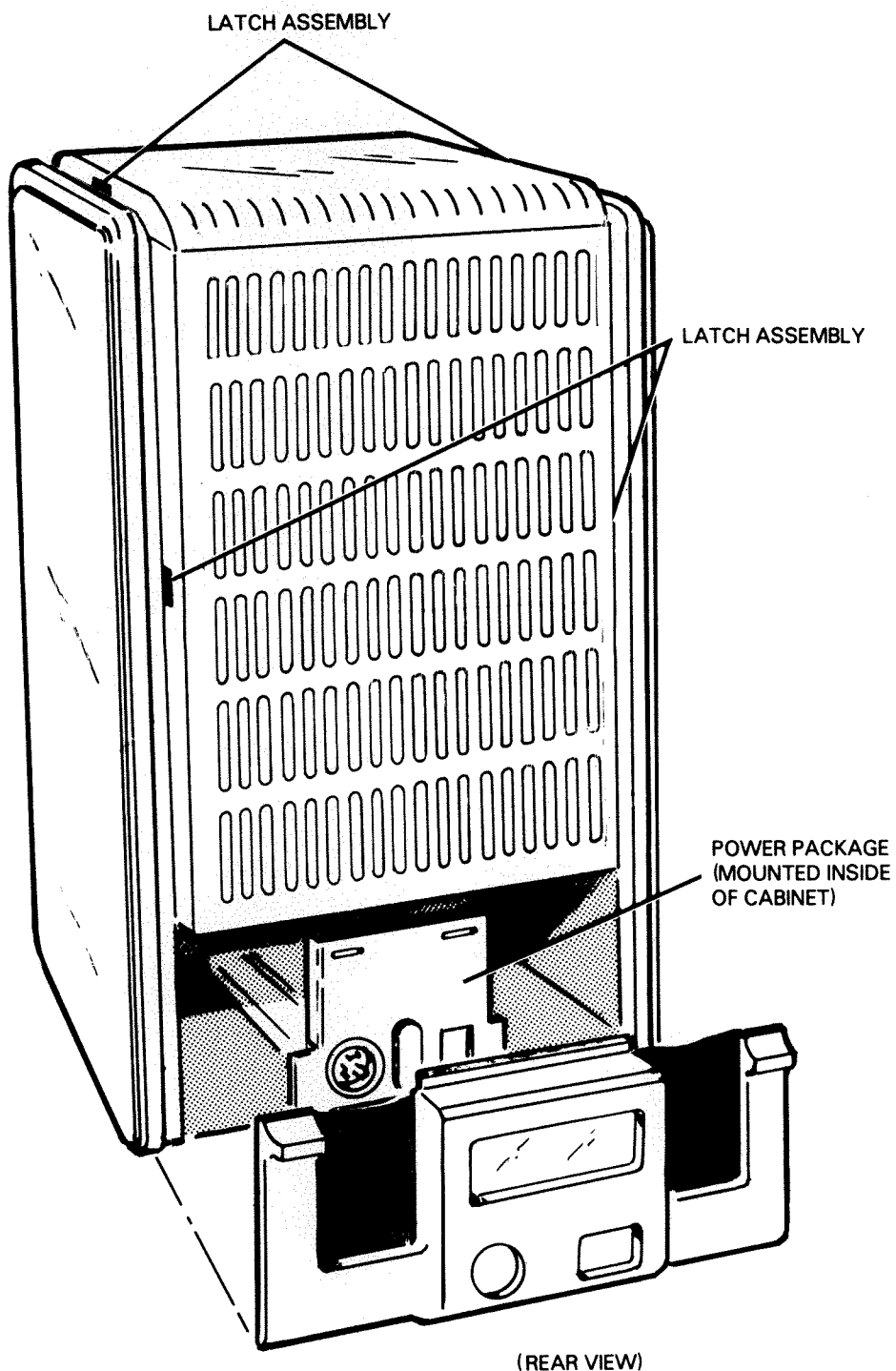

FS-07103

Figure 1-4. FRU Locations (6237 only) (Sheet 2 of 2)

## 1.4 DISK DRIVE SUBSYSTEM DESCRIPTION

The following subsections give a brief description of the major FRUs in the 6236/6237 disk drive subsystem.

1.4.1 Printed Circuit Boards - There are seven major PCBs in the 6236 disk drive. The control logic PCB, read/write PCB, position control PCB, power control PCB, power amplifier PCB and spindle control PCB are mounted on the PCB support assembly. The front panel PCB is mounted on the front cover. Refer to Figure 1-3 for the mounting location of the PCBs. Following is a brief description of each PCB.

1.4.1.1 Control Logic PCB - The control logic PCB contains a microECLIPSE™ computer and provides communication with the controller PCB, read/write channel processing, overall device control and status monitoring. It also performs supervisory control for the position control system via a buffered version of the microECLIPSE addr/data bus. The 6236/6237 power-up diagnostics are resident in the microECLIPSE program memory with access to the front panel PCB display for device status reporting.

1.4.1.2 Read/Write PCB - The read/write PCB processes all read/write data to/from the control logic PCB's R/W Processor to the Head Disk Assembly (HDA). The read/write and servo read channel functions are performed by the read/write PCB. The read/write channel operates in two modes; write and read. During a write, encoded digital serial write data from the control logic PCB is converted to a write current waveform for the selected head. During a read, readback from the head selected is amplified, digitized, and synchronized to a data clock and transmitted to the control logic PCB in a serial bit stream to be decoded in the read/write processor. In the servo read channel, readback from the servo head is processed to provide a linear position signal for the track following control system; a disk synchronous clock system for read and write operations, coarse radial band information embedded in the servo format and index and sector timing.

1.4.1.3 Position Control PCB - The position control PCB controls all positioning of the carriage head assembly (located in the HDA), in both access and track following modes. It communicates to the control logic PCB over the buffered microECLIPSE addr/data bus and develops a motor drive signal for the power amplifier. Two operational modes are utilized; seek and track follow. During a seek operation linear position information from the read/write PCB and cylinder difference information from the control logic PCB are used to move the carriage/head assembly from one radial position to another. During a track follow operation the position control PCB maintains the carriage on track center line for performing all read/write operations.

1.4.1.4 Power Control PCB - The power control PCB contains linear regulators to provide control voltages (+5/-5 and +15/-15) utilized by the disk drives, and other PCBs; and circuitry for monitoring and displaying dc voltages. All drive power status is reported to the control logic PCB via the power control status. All disk drive power on/off and reset functions are controlled by the power control PCB.

1.4.1.5 Power Amplifier PCB - The power amplifier PCB converts the output of the position control PCB to a high level current for controlling the acceleration and deceleration of the carriage/head assembly. It consists of current control circuitry, servo unsafe sensing circuitry, and a Light Emitting Diode (LED) error display.

1.4.1.6 Spindle Control PCB - The spindle control PCB is a closed-loop control system for the dc brushless motor driving the spindle. It controls the acceleration during spindle turn on and monitors the rotational speed of the disk pack via Hall effect devices located in the motor. Spindle status is reported to the control logic PCB via the power control status. Disk drive error conditions are indicated by the spindle control PCB fault LEDs.

1.4.1.7 Front Panel PCB - The front panel PCB contains the power ON/OFF switch, diagnostic/unit switches, system status LEDs, and three (seven-segment) digital display indicators for error, status, and unit number reporting. The front panel PCB contains the control logic for the unit number display, power-up diagnostic fault readout, and system status LEDs. It interfaces to the control logic PCB via the power status on the power control PCB.

1.4.2 Controller PCB - The controller PCB is CPU resident, as shown in Figure 1-3. It is a single 38.2 x 38.2 cm (15 x 15 inch) microprocessor driven, intelligent PCB. It contains all the logic necessary to transfer data between the host CPU and the disk drive via the BMCI. Programmed I/O (PIO) transfers are information and command transfers between the host and the controller of the controller and the host. The controller communicates with the 6236 disk drive via a COMMAND/DATA bus. The controller PCB contains jumpers for selecting the disk drive subsystem device code.

1.4.3 Head Disk Assembly - The Head Disk Assembly (HDA) is mounted to the base weldment assembly as shown in Figure 1-3. It contains the following assemblies: recording media, linear motor interface PCB, read/write interface PCB, read/write heads, servo head, linear motor, spindle motor, carriage assembly, and closed-loop air system. On the external shaft of the spindle motor there is a blower assembly which provides a continuous circulation of air within the disk drive. The assemblies are mounted in the aluminum HDA casting. The HDA is sealed at the factory to maintain internal cleanliness. The cover of the sealed HDA should not be opened because it will cause contamination of both the heads and the recording media.

1.4.4 Power Supply Assembly - The power supply assembly is mounted to the rear of the base weldment assembly as shown in Figure 1-3. The power supply is single phase; it develops dc power and distributes it to the power control PCB, spindle control PCB, and power amplifier PCB. The power supply consists of the power chassis PCB, ac line filter, ferroresonant transformer, fuse, and ac circuit breaker. The ac circuit breaker and fuse are located in the rear of the disk drive. The power supply can be configured for worldwide power compatibility. Power configuration is determined by the position of the voltage/frequency stunt plugs at the rear of the power supply and corresponding ac circuit breaker (the ac circuit breaker is not part of the power supply assembly, it is a FRU assembly).

1.4.5 Coarse Air Filter - The coarse air filter is mounted to the front of the internal front panel as shown in Figure 1-3. The function of the coarse air filter is to filter the air that is drawn into the disk drive by the spindle blower assembly. The filter must be cleaned and/or replaced according to the cleaning/replacement schedule listed in Section 2, to protect the disk drive from intaking contaminated air.

1.4.6 Switch Assembly (Model 6237 only) - The switch assembly is mounted in the front of the 6237 disk drive installation cabinet as shown in Figure 1-4. The switch is connected to the power package and to the power supply assembly. It controls the flow of ac power from the power package to the power supply assembly.

1.4.7 Latch Assembly (Model 6237 only) - The latch assembly is mounted in the rear and top of the installation cabinet as shown in Figure 1-4. The latch assembly secures the top and rear weldment panels of the installation in the closed position.

1.4.8 Power Package (Model 6237 only) - The power package is mounted in the bottom of the 6237 installation cabinet as shown in Figure 1-4. It contains the power distribution box, jumper kit, related cabling, line filter, ac circuit breaker, and ac power cord. The power distribution box jumper kit can be configured for worldwide power compatibility. The power package converts ac from the power source into either two or three phase ac power. It provides ac power and distributes it to the three model 6236 drives that are mounted in the 6237 installation cabinet. The circuit breaker is mounted on the rear of the power distribution box to provide circuit overload protection.



## SECTION 2

### OPERATING CONTROLS AND PROCEDURES

#### NOTE

THE OPERATING INSTRUCTIONS AND CONTROLS DESCRIBED IN THIS SECTION ARE INTENDED FOR THE MAINTENANCE ENGINEER ONLY. EQUIPMENT OPERATORS SHOULD REFER TO THE OPERATOR'S GUIDE, DG # 014-701000, FOR DISK DRIVE OPERATING INSTRUCTIONS.

This section describes the operating controls and procedures for the 6236/6237 disk drive subsystem. Also the following user-initiated sequences and instructions are described:

- Powering up/down the disk drive subsystem
- Disk drive monitoring
- Emergency conditions
- User maintenance

#### 2.1 CONTROL SWITCHES AND INDICATOR LEDS

The following subsections describe the function of the control switches and indicator LEDs on the 6236/6237 disk drive subsystem.

2.1.1 External Switches - There is one external control switch, the power ON/OFF switch, on the 6236 disk drive. The 6237 disk drive has one external control switch per drive in the configuration cabinet and an external power ON/OFF switch located on the Meter High Cabinet. Table 2-1 describes the function of the external switches. Figures 2-1 and 2-2 show their location.

**Table 2-1. External Switches**

SWITCH	LOCATION	FUNCTION
POWER ON/OFF	Front Panel PCB	A two position switch that controls the flow of power to the 6236/6237 disk drive. In the 1 (ON) position the power is on and in the 0 (OFF) position the power is off.
POWER ON/OFF	Meter High Cabinet	A two position switch that controls the flow of ac power from the power package (power distribution box) to the power supply assembly. In the 1 (ON) position the power is on and in the 0 (OFF) position the power is off.

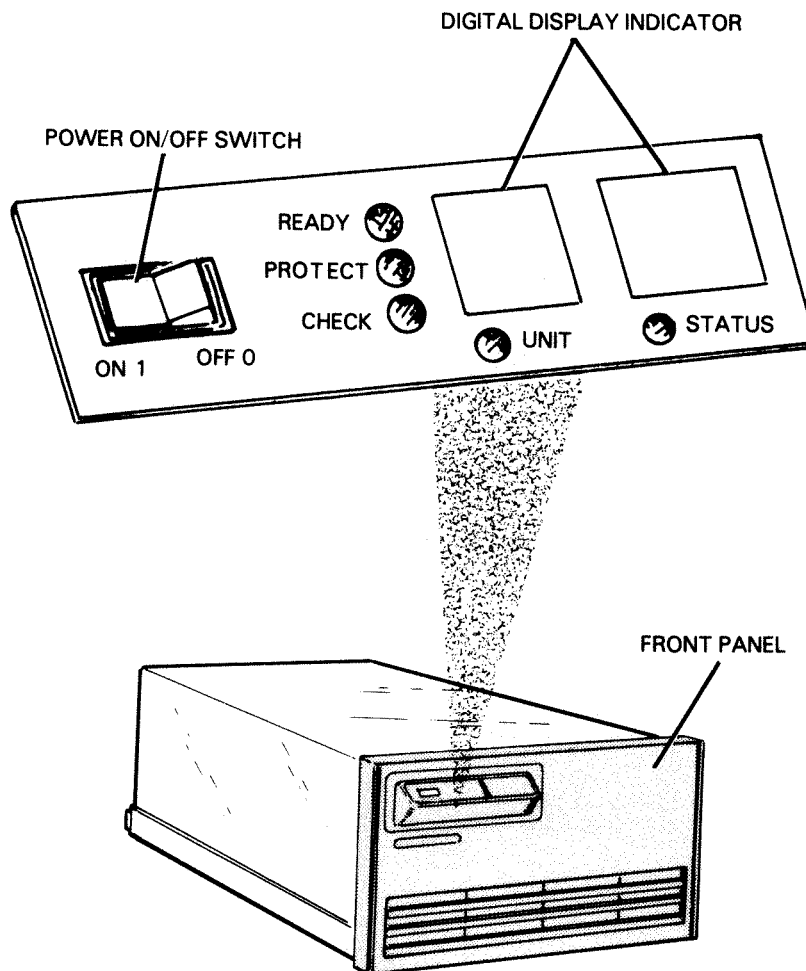

FS-07104

**Figure 2-1. External Controls and Indicator LEDs**

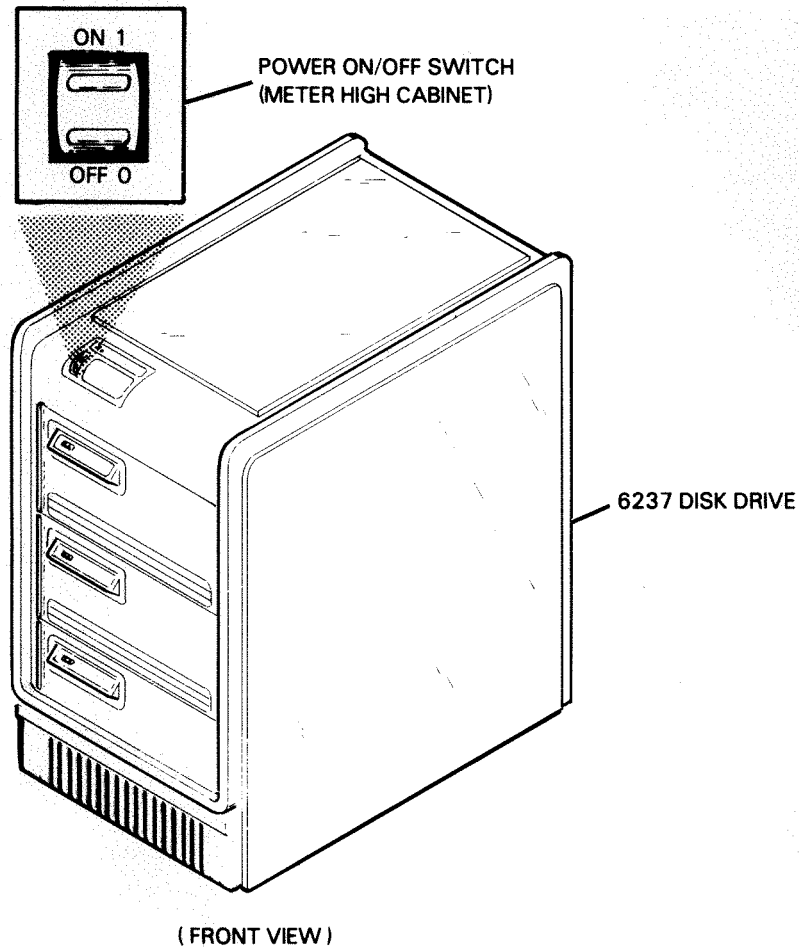

FS-07105

Figure 2-2. External Control Switches (6237)

## 2.1.2 Circuit Breakers -

### 6236 Disk Drive

The 6236 disk drive has one circuit breaker located in the rear of the drive as shown in Figure 2-3. The circuit breaker controls the flow of ac power from the ac power source to the power supply assembly. Refer to Figure 2-3 for the circuit breaker ON/OFF position.

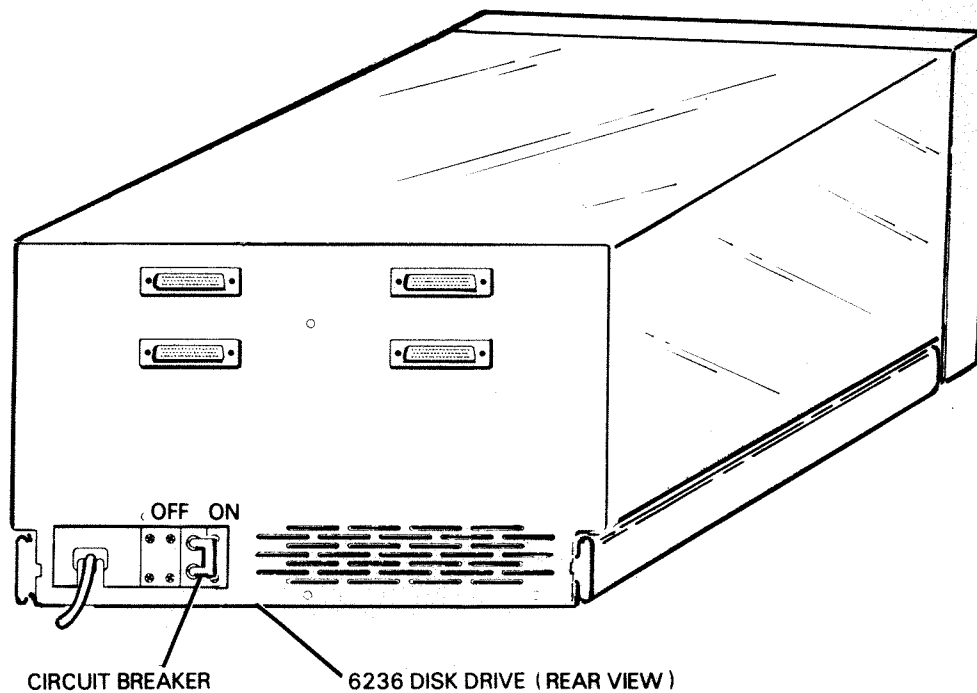

FS-07106

Figure 2-3. Circuit Breaker (6236)

### 6237 Disk Drive

The 6237 disk drive has four circuit breakers located in the rear of the drive as shown in Figure 2-4.

2.1.2.1 Main Circuit Breaker - The main circuit breaker is accessible with the rear panel installed. The main circuit breaker controls the flow of ac power from the ac power source to the power package (power distribution box). Refer to Figure 2-4 for the main circuit breaker ON/OFF position.

2.1.2.2 Disk Drive Circuit Breakers - The disk drive circuit breakers (3) are accessible with the Meter High Cabinet rear panel removed. The procedure for the removal or replacement of the rear panel follows (refer to Figure 2-4):

1. To remove the rear panel: Insert a screw driver into the latches and push the latches toward the center of the cabinet. The rear panel can then be removed.
2. To replace the rear panel: Set the panel in position and carefully push it into place (with the latches in the locked position).

Refer to Figure 2-4 for the 6237 disk drive circuit breaker ON/OFF position.

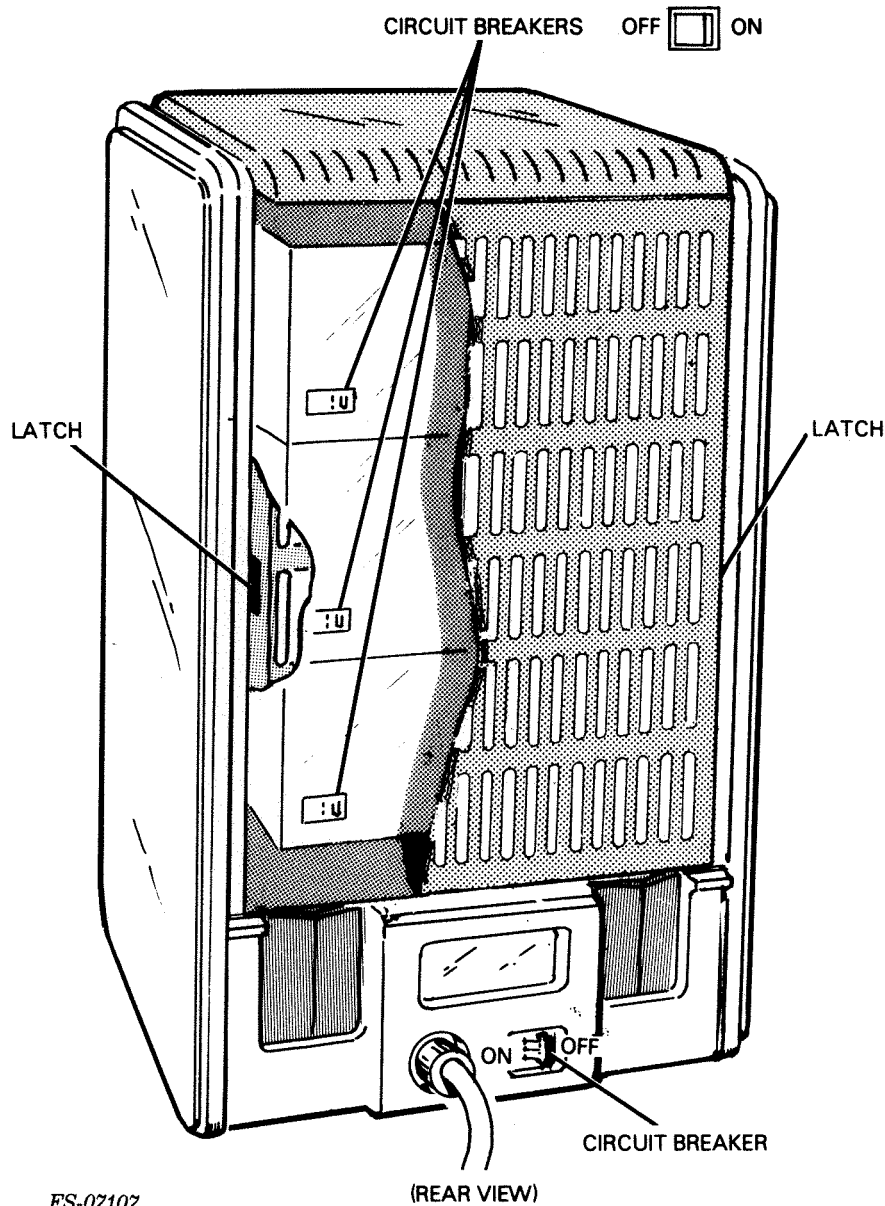

Figure 2-4. Meter High Cabinet Circuit Breakers (6237)

2.1.3 Internal Switches - There are six internal switches on the 6236 disk drive; two diagnostic, two unit, one write protect and one servo disable.

Unit and Diagnostic Switches

The unit and diagnostic switches are located on the front panel PCB and are accessible with the front panel removed as shown in Figure 2-5. The procedure for the removal or replacement of the front panel follows:

1. To remove the front panel: Depress the two tabs on the sides of the front panel assembly and remove the panel from the chassis.
2. To replace the front panel: Position the front panel correctly, depress the two tabs on the front panel, and install it to the front of the disk drive.

Switch Positions:

The ON/OFF position for SW1 to SW4 is as follows:

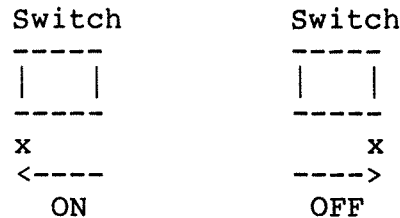

2.1.3.1 Unit Switches - The unit switches (SW1 and SW2) control the unit number of the drive. The drive can be assigned unit number 0, 1, 2, or 3 (the switch combinations are based on the binary number system; switch ON = 1, switch OFF = 0). The 6236/6237 controller PCB will support four drives (or units). The unit switches must be set when the drive is installed.

**CAUTION**

Do not change the unit switch setting while the drive is performing a read/write operation. The unit switches have a direct effect on the drive's interface hardware. Changing the unit switches while the drive is performing a read/write operation will cause an error condition.

Refer to Table 2-2 for a functional description of the unit switches SW1 and SW2.

Table 2-2. Unit Switches SW1 and SW2

UNIT NUMBER	SW2	SW1
0	OFF	OFF
1	OFF	ON
2	ON	OFF
3	ON	ON

Data General Corporation (DGC) has prepared this manual for use by DGC personnel and customers as a guide to the proper installation, operation, and maintenance of DGC equipment and software. The drawings and specifications contained herein are the property of DGC and shall neither be reproduced in whole or in part without DGC's prior written approval nor be implied to grant any license to make, use, or sell equipment manufactured in accordance herewith.

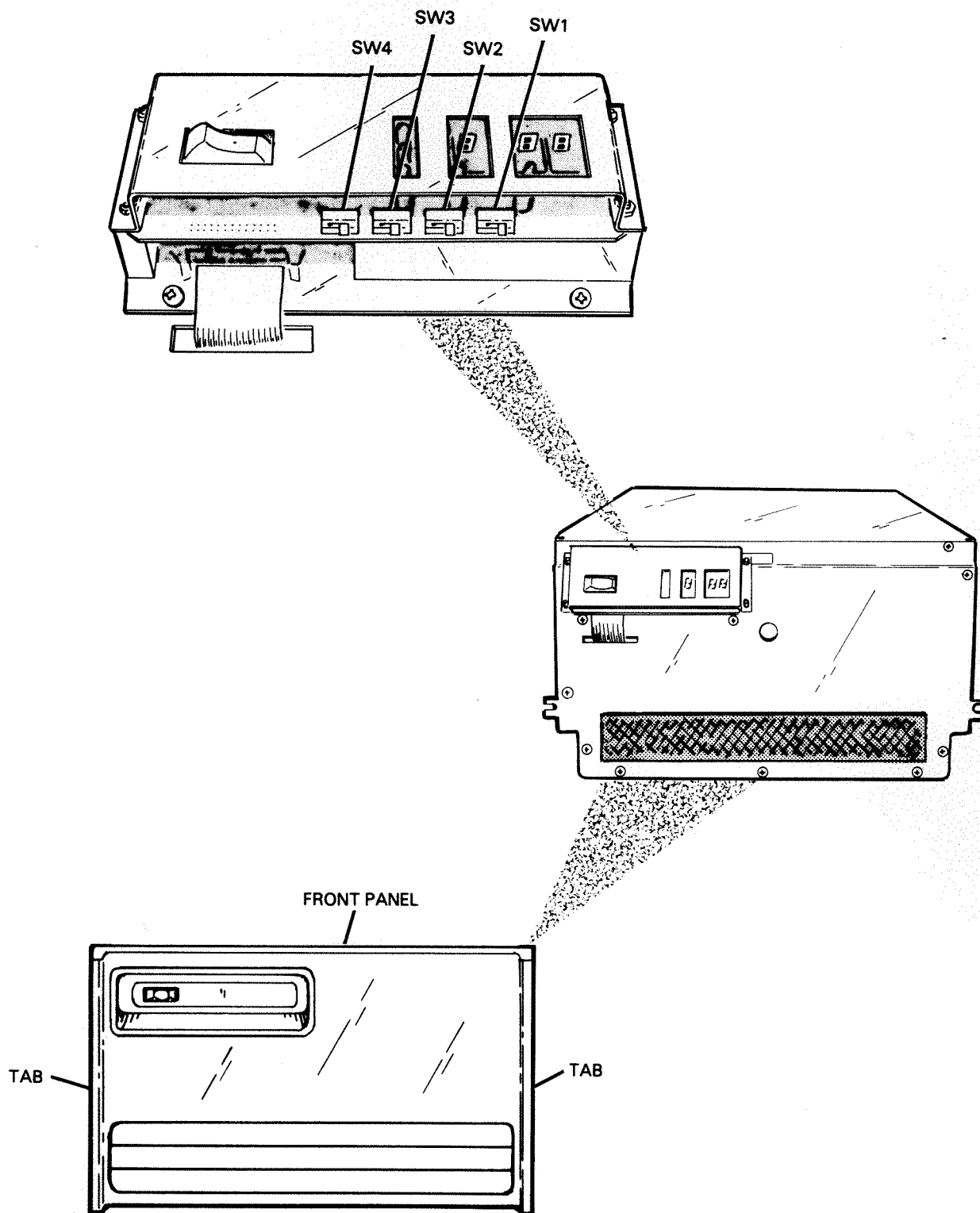

FS-07108

Figure 2-5. Unit and Diagnostic Switches

2.1.3.2 Diagnostic Switches - The position of the diagnostic and unit switch affect the front panel digital display indicator. When the disk drive is in a READY state there are four separate operations that can be displayed. An arbitration scheme is built into the drive logic so that the operations do not conflict with one another. The four operations are:

1. Unit switch monitoring
2. Error reporter
3. Fault monitor
4. Cylinder display

The ON-LINE drive states: Normal Operating Mode and Display Current Cylinder Mode use the display arbitration scheme as described below:

#### Drive State #1 - Normal Operating Mode

The normal operating mode for the drive is to set the SW3 and SW4 in the OFF position (refer to Table 2-3). In this state the drive will display the unit number in the unit number digital display. If the fault monitor is active and it has an error code to display, the fault monitor overrides the error reporter. If the fault monitor is inactive, the error reporter gains control of the status digital display indicator. In this case the error is soft and a soft reset from the controller will extinguish (blank) the status digital display indicator.

#### Drive State #2 - Display Current Cylinder Mode

The display current cylinder mode for the drive is SW3=OFF and SW4=ON (refer to Table 2-3). In this state the unit switch monitoring, the error reporter, and fault monitoring are overridden by the cylinder display operation. The current cylinder number appears on the three segment digital display indicator (number is in decimal).

#### NOTE

If the drive is in the Display Current Cylinder mode and the servo system is disabled, the digital display indicator will display "s db" (Servo System Disabled).

The diagnostic switches aid in the identification of the source of both hard drive faults and intermittent drive and/or system faults. The switch group definitions are divided into two groups: ON-LINE and OFF-LINE.

#### NOTE

SW3 determines the ON-LINE or OFF-LINE status of the drive: SW3 ON=OFF-LINE, SW3 OFF=ON-LINE.

Refer to Table 2-3 for a functional description of the diagnostic switches (SW3 and SW4).



Table 2-3. Diagnostic Switches SW3 and SW4

DRIVE STATUS	FUNCTION	SW4	SW3
ON-LINE	Normal Operating Mode	OFF	OFF
ON-LINE	Display Current Cylinder	ON	OFF
OFF-LINE	Loop on all Power-up Tests*	OFF	ON
OFF-LINE	Loop on Random Seeks*	ON	ON

\* NOTE: When switches are in this position the drive will continue to loop on Power-up Tests, drive will not come READY.

The following paragraphs describe diagnostic switch functions:

- ON-LINE - Normal Operating Mode - SW4=OFF, SW3=OFF

If SW3 and SW4 are both OFF, the drive is in normal operating mode. If the drive is READY and this mode is active the unit number is displayed on the left-most seven segment digital display indicator and the UNIT LED is illuminated.

If an error is detected by the microECLIPSE CPU (control logic PCB) while the switches are in this state, the error code is written on the two right-most seven segment digital display indicators and the STATUS LED is illuminated. If the controller PCB detects this error and if it transmits a Soft Reset command, the error code is blanked and the STATUS LED is extinguished. The error code LED ON/OFF sequence will occur so rapidly that the error code will be extremely difficult to see on the digital display indicator. To identify what error code appeared, the drive will have to be taken OFF-LINE and the error log examined. Refer to OFF-LINE - Power-up Tests for the procedure.

If a hard error is detected during the power-up tests or a hard error has been detected after the completion of the power-up tests, the error code will appear on the digital display indicator. A Soft-Reset from the controller PCB will not blank the digital display indicator. If the microECLIPSE has detected several hard drive faults, the software identifies the most serious drive fault currently pending and displays its error code.

- ON-LINE - Display Current Cylinder Mode - SW3=OFF, SW4=ON

If SW3 is OFF and SW4 is ON, the drive displays the current cylinder number on the digital display indicator (NOTE: Cylinder Display is in decimal). If the servo system is in a DISABLED state, "s db" is displayed. When the drive is in cylinder display mode, error codes do not appear on the digital display indicator. If a soft error is detected the microECLIPSE CPU causes the STATUS LED to illuminate. When the controller sends a Soft-Reset command, the STATUS LED is extinguished. If a hard error occurs while the drive is in the cylinder display mode, the STATUS LED remains illuminated.

- OFF-LINE - Loop on All Power-up Tests - SW3=ON, SW4=OFF

If SW3 is ON and SW4 is OFF, the drive is in loop on all power-up tests mode. The purpose of the OFF-LINE switch is to provide a means of running the power-up self tests. The switch also provides a means for examining the drive's error log. The effect of this switch is determined by the READY status of the drive when the switch is set.

If the SW3 is ON while the drive is performing power-up tests and SW4 is ON, the microECLIPSE CPU will loop on random seeks. If the SW3 is ON while the drive is running the power-up tests and SW4 is OFF, the microECLIPSE CPU will loop on the entire power-up tests series and the drive will never come READY.

If the SW3 is set in the ON position while the drive is READY (ON-LINE) and the microECLIPSE CPU is idling, the microECLIPSE dumps the error log. The error codes are displayed from the most recent to oldest.

At the end of dumping the error log the microECLIPSE CPU monitors SW3 to see if it is still ON. If SW3 is still ON, the microECLIPSE CPU starts the power-up tests. If SW3 is OFF, the microECLIPSE CPU sets READY, and returns the drive to ON-LINE status.

- OFF-LINE - Loop on Random Seeks- SW3=ON, SW4=ON

If SW3 is ON and SW4 is ON, the drive is in loop on random seeks mode. If SW3 is ON and the microECLIPSE CPU is executing power-up test series, the microECLIPSE performs the positioner test (test 05). It monitors SW4 to see if SW4 is ON. If SW4 is ON, the microECLIPSE runs the loop on random seeks test.

When the drive enters this test the unit message bit is turned off and a "5" appears on the digital display indicator. As in the normal hard reset sequence a "5" is the test code for the positioner test. A "00" is written to the error digits on the digital display indicator. The "5" on the unit digit is ON for five seeks, OFF for five seeks. The value on the error digits is a pass count in hexadecimal. Each pass is 50K seeks. Refer to Table 2-4 for a Pass/Seek count.

No seek recovery algorithm is invoked when running the seek loop test. If a seek fails or a faulty drive status occurs, the test is aborted and the error code is transmitted to the digital display indicator. The microECLIPSE CPU waits for the diagnostic switches to be changed by the user. This process insure that the error code digital display indicator remains set until the user has acknowledged the conclusion of the loop on random seeks test.

Table 2-4. Pass/Seek Count

HEXADECIMAL PASS COUNT	MILLION SEEKS
10	0.8
14	1.0
20	1.6
40	3.2
80	6.4
A0	8.0
C8	10.0
FF	12.8

2.1.3.3 Protect and Servo Disable Switches - The write protect switch is located on the read/write PCB and the servo disable switch is located on the power amplifier PCB as shown in Figure 2-6. They are accessible with the drive in the service (access) position through labeled access holes in the top cover. The procedure for gaining access to the drive is as follows (refer to Figure 2-7):

Gaining access to the drive (service position):

1. Depress the two tabs on the sides of the front panel assembly and remove the panel from the chassis.
2. Remove the two mounting screws securing the front cover to the installation cabinet.
3. Slide the drive forward and out of the installation cabinet.

Securing the drive in the installation cabinet (closing):

4. Carefully slide the drive back into the installation cabinet until the front cover mounting brackets are flush with the installation cabinet rack mount supports.
5. Secure the drive in the installation cabinet by tightening the two mounting screws.

#### CAUTION

Damage to the disk drive will occur if the disk drive is powered-up without the coarse air filter installed on the front cover.

6. Verify that the coarse air filter is present and positioned correctly on the front cover, depress the tabs on the front panel and install it on the front of the disk drive.

Refer to Table 2-5 for a functional description of the internal switches on the 6236/6237 disk drive.

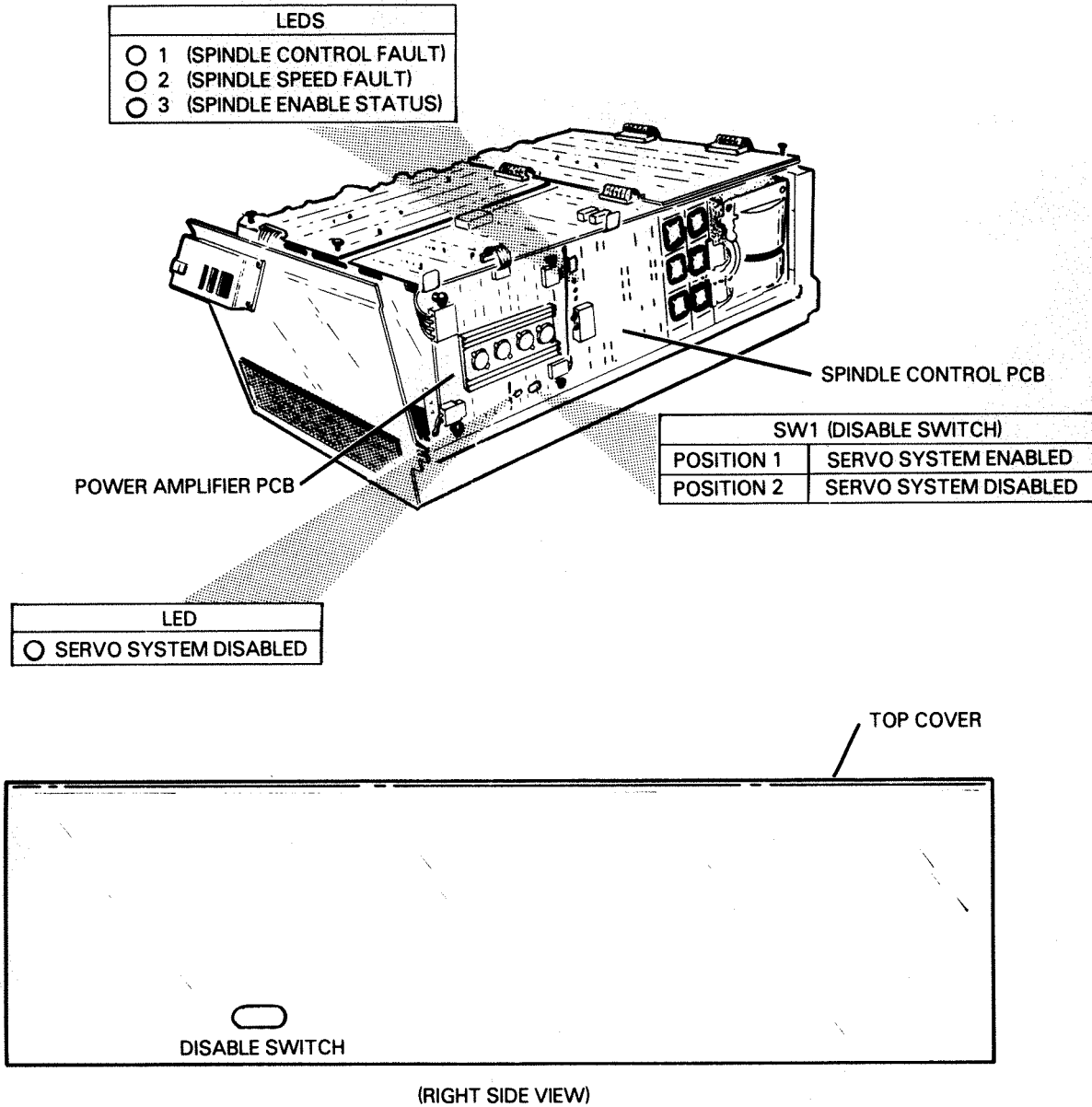

FS-07109

Figure 2-6. Internal Switches and Indicator LEDs (Sheet 1 of 2)

Data General Corporation (DGC) has prepared this manual for use by DGC personnel and customers as a guide to the proper installation, operation, and maintenance of DGC equipment and software. The drawings and specifications contained herein are the property of DGC and shall neither be reproduced in whole or in part without DGC's prior written approval nor be implied to grant any license to make, use, or sell equipment manufactured in accordance herewith.

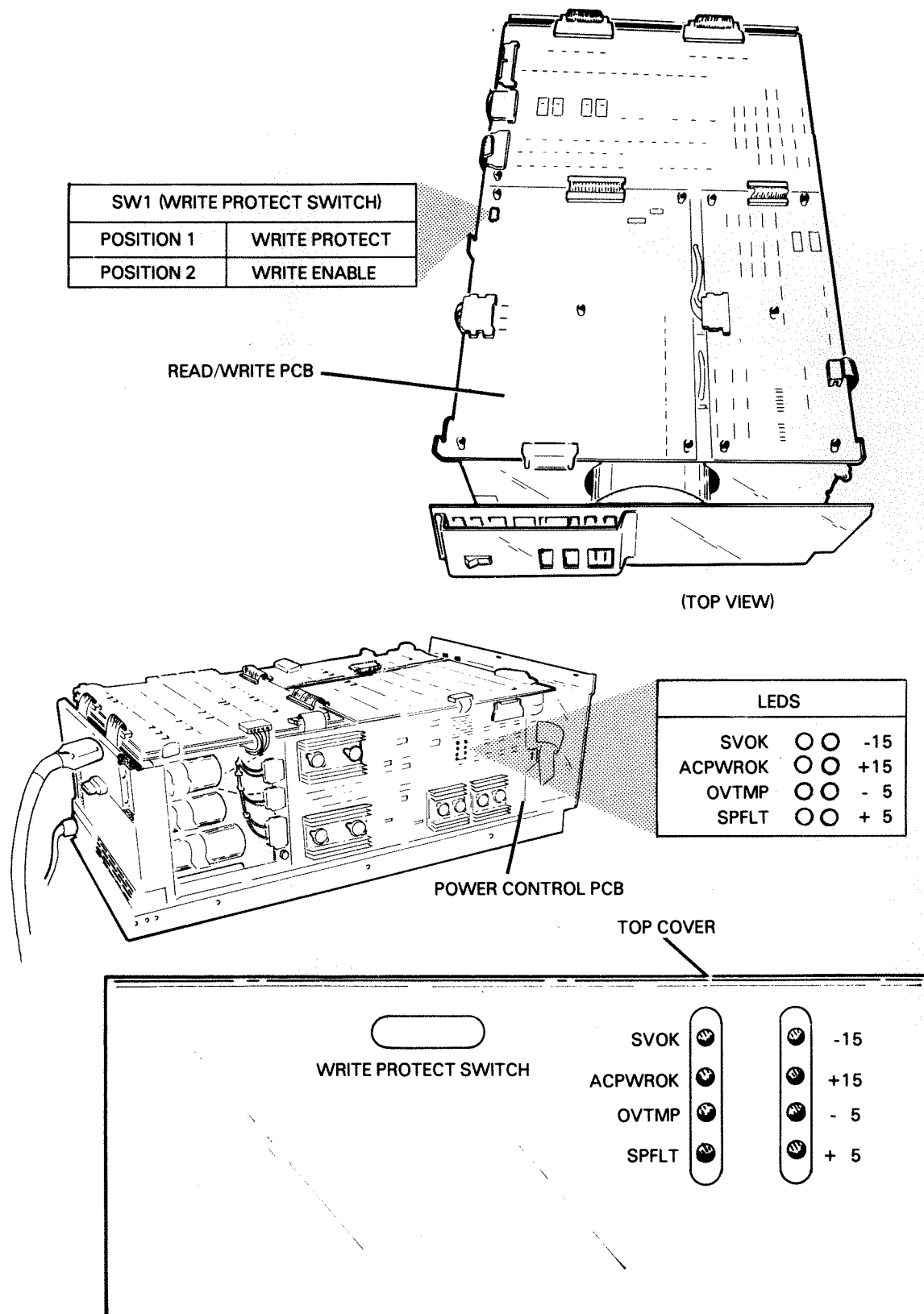

FS-07109

Figure 2-6. Internal Switches and Indicator LEDES (Sheet 2 of 2)

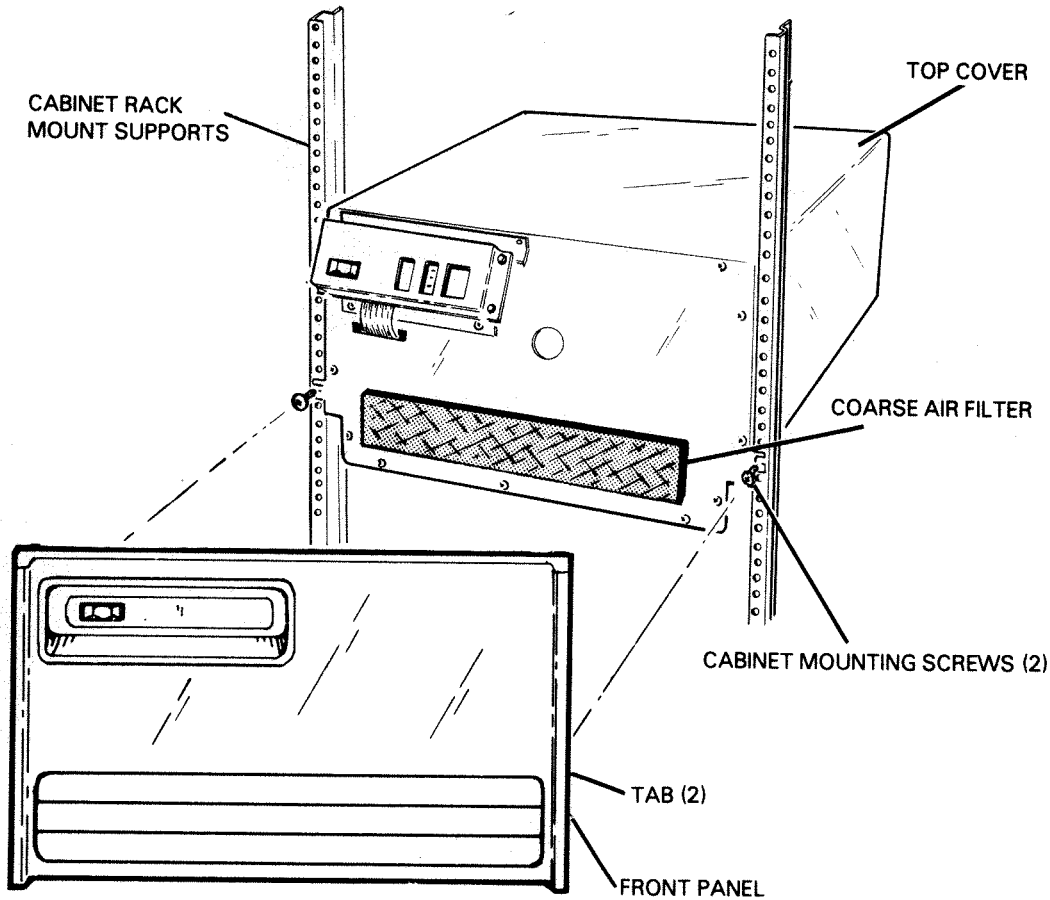

FS-07110

Figure 2-7. Gaining Access to the Drive

Table 2-5. Internal Switches

SWITCH	LOCATION	POSITION	FUNCTION
WRITE PROTECT	Read/Write PCB	#1	Drive is in the write protect mode, data can not be written to the disk. Causes PROTECT LED on front panel to illuminate.
		#2	Drive is in write enable mode, data can be written to the disk.
DISABLE	Power Amplifier PCB	#1	Servo system is enabled.
		#2	Servo system is disabled. Causes LED (servo system disabled) to illuminate on the power amplifier PCB.

2.1.4 Indicator LEDs - The 6236/6237 disk drive has external and internal indicator LEDs. Each indicator LED is either ON or OFF, indicating an existing condition or drive status.

2.1.4.1 External Indicator LEDs - The external LEDs are the READY, PROTECT, CHECK, UNIT, and STATUS LEDs. They can be viewed on the front panel as shown in Figure 2-1. The CHECK LED is driven directly by the power control PCB. The READY, PROTECT, and UNIT LEDs are controlled by the microECLIPSE CPU on the control logic PCB. Refer to Table 2-6 for an external LED functional description.

Table 2-6. External Indicator LEDs (Front Panel PCB) (Sheet 1 of 3)

LED	STATE	NORMAL STATE	FUNCTION
READY	ON		Indicates that the drive is ready to operate and that the following conditions exist: <ul style="list-style-type: none"> <li>• Drive is powered-up</li> <li>• Drive spindle is up to speed</li> <li>• Drive is at proper temperature</li> <li>• Power-up tests have been successfully completed or an error condition was encountered during the power-up tests (the drive will come ready with error code appearing on the status display and the drive will be in read only mode).</li> <li>• The drive can accept initiate sequence commands from the controller PCB.</li> </ul>
	OFF		Indicates that the drive is not ready to operate or able to receive commands from the controller PCB. The drive goes not ready whenever the microECLIPSE CPU receives a hard-reset. Once the hard-reset sequence has completed, the microECLIPSE CPU sets ready. (If the microECLIPSE CPU has not seen a shut-down fault and the front panel diagnostic switch is not holding the drive OFF-LINE, the drive will not come ready.)
		ON	The normal state for the READY LED is ON, if the circuit breaker and the power ON/OFF switches are in the ON position, and after the successful completion of the power-up tests.
PROTECT	ON		The drive can not write to the disk. A protect state can exist under the following conditions: <ul style="list-style-type: none"> <li>• The write protect switch on the read/write PCB is set to position #1 (ON/write protect)</li> <li>• The microECLIPSE CPU issued a command to set the write protect condition ON.</li> <li>• The microECLIPSE CPU has set the write protect condition because a read/write error has occurred.</li> </ul>

Table 2-6. External Indicator LEDES (Front Panel PCB) (Sheet 2 of 3)

LED	STATE	NORMAL STATE	FUNCTION
PROTECT	OFF		The drive can write to the disk. (NOTE: If there is a malfunction condition existing in the microECLIPSE CPU it is possible for the drive to be in the write protect mode while the PROTECT LED is OFF.)
		OFF	The normal state for the PROTECT LED is OFF, if the write protect switch is in position #2 (OFF/write enable) and the power ON/OFF switch is in the ON position.
CHECK	ON		If the ac power cord is plugged into an ac source and the ac circuit breaker is in the ON position the CHECK LED illuminates to indicate the presence of ac power. If the the power ON/OFF switch is set in the ON position, the CHECK LED extinguishes. If the CHECK LED illuminates with the power ON/OFF switch in the ON position, the drive has powered-down due to a dc power fault. It is an indication that dc power has been interrupted and only ac power is present. If this condition exists, the power ON/OFF switch must be recycled.
		OFF	If the power ON/OFF switch is set in the ON position, the normal state for CHECK LED is OFF. If the power ON/OFF switch is set in the OFF position, the normal state for the CHECK LED is ON.
UNIT	ON		It indicates that the drive is in unit display mode, the number on the unit digital display indicator is displaying the current unit number assigned to the drive. (NOTE: The UNIT LED is affected by the position of SW3 and SW4 on the front panel PCB).
	OFF		It indicates that the drive is in cylinder display mode. The number on the unit digital display indicator is displaying the current cylinder number
		ON	If the digital display indicator panel is set in the unit number and error display mode, the normal state for the UNIT LED is ON.
STATUS	ON		It indicates that an error condition has interrupted the normal operation of the drive. A soft reset from the controller PCB clears the STATUS LED when the error is soft. If the error is hard, the status LED remains illuminated. When the STATUS LED is illuminated an error code is displayed on the digital display indicator.



**Table 2-6. External Indicator LEDs (Front Panel PCB) (Sheet 3 of 3)**

LED	STATE	NORMAL STATE	FUNCTION
STATUS	OFF		The drive is operating without an error condition present.
		OFF	The normal state for the STATUS LED is OFF, indicating the absence of an error condition.

2.1.4.2 Front Panel Digital Display Indicator - The front panel digital display indicator consists of a group of three seven-segment lights that report drive UNIT and STATUS information. The digital display indicator is driven by the microECLIPSE CPU on the control logic PCB. Refer to Figure 2-1 for an illustration of the digital display indicator on the front panel. The following paragraphs provide a functional description of the UNIT and STATUS digital displays.

**NOTE**

The status transmitted to the digital display indicator is affected by the position of SW1 to SW4 on the front panel PCB.

- UNIT Digital Display Indicator

The UNIT digital display indicator displays the unit number of the drive. The unit number is set when the drive is installed (SW1 and SW2 on the front panel PCB). If the microECLIPSE CPU detects a shut-down error status during the power-up test, the halt code "F" appears on the UNIT digital display indicator.

- STATUS Digital Display Indicator

The STATUS digital display indicator displays error codes that are detected during the power-up sequence and/or during drive operation. The valid digits are "0" through "9" and "A", "B", "C", "D", and "E". The range of valid error codes is from "20" to "DD". When an error code is displayed refer to Figure 2-8 for a front panel display - error code listing.

2.1.4.3 Internal LEDs - Refer to Figure 2-6 for an illustration of the location of the internal LEDs and to Tables 2-7 through 2-9 for a functional description.

**Table 2-7. Power Control PCB LEDs**

LED	NORMAL STATE	DRIVE STATUS	ERROR STATE	DRIVE STATUS
SVOK	ON	When power ON/OFF switch is set in the ON position LED illuminates.	OFF	Indicates error condition in the power servo system, blown fuse on the power amplifier PCB causes LED to extinguish.
ACPWROK	ON	When power ON/OFF switch is set in the ON position LED illuminates.	OFF	Indicates loss of ac power, LED momentarily blinks, the drive powers-down.
OVTMP	OFF	Indicates normal temperature in heatsinks.	ON	Indicates over-temperature condition in the heatsinks, causes the drive to power-down.
SPFLT	OFF	Indicates normal operating condition in the spindle control system.	ON	Indicates fault condition in the spindle control system, causes the drive to power-down.
-15	ON	Indicates the presence of -20Vdc.	OFF	Indicates the loss of -20Vdc, causes the drive to power-down.
+15	ON	Indicates the presence of +20Vdc.	OFF	Indicates the loss of +20Vdc, causes the drive to power-down.
-5	ON	Indicates the presence of -8Vdc.	OFF	Indicates the loss of -8Vdc, causes the drive to power-down.
+5	ON	Indicates the presence of +8Vdc.	OFF	Indicates the loss of +8Vdc, causes the drive to power-down.

Table 2-8. Spindle Control PCB LEDs

LED	NORMAL STATE	DRIVE STATUS	ERROR STATE	DRIVE STATUS
01 (SPINDLE CONTROL FAULT)	OFF	Indicates normal condition in spindle control system.	ON	Indicates fault in the spindle control system LED momentarily blinks, the drive powers-down.
02 (SPINDLE SPEED FAULT)	OFF	Indicates normal condition in spindle speed, spindle is up to correct operating speed.	ON	Indicates spindle speed fault. (NOTE: LED will illuminate during 35 sec power-up test (07) and extinguishes when the spindle reaches correct operating speed.)
03 (SPINDLE ENABLE STATUS)	ON	Indicates spindle is in an enabled state.	OFF	Indicates spindle is not in an enabled state.

Table 2-9. Power Amplifier PCB LED

LED	NORMAL STATE	DRIVE STATUS	ERROR STATE	DRIVE STATUS
SERVO SYSTEM DISABLED	OFF	Indicates servo system is in an enabled state.	ON	Indicates servo system is in a disabled state, the LED illuminates when SW1 (Disable Switch) is in position #2 (DISABLED). (NOTE: LED illuminates during 35 sec power-up test (07) and extinguishes when spindle reaches correct operating speed.)

## 2.2 OPERATING PROCEDURES

The following subsections describe the operating procedures for the 6236/6237 disk drive subsystem and the procedures for handling emergency conditions.

2.2.1 Power-Up Procedure - The power-up procedure supplies power to the disk drive, making it ready for full operation. After the user begins the procedure, the 6236/6237 disk drive subsystem performs power-up tests to verify that the drive is operational. The test results are displayed on the front control panel display. Refer to Figure 2-8 for front panel display - error code listing.

The 6236 disk drive subsystem has a main ac circuit breaker located in the rear of the drive (refer to Figure 2-3). The 6237 disk drive subsystem has a power package ac circuit breaker located in the rear of the Meter High Cabinet (refer to Figure 2-4). The main ac circuit breaker and/or the power package ac circuit breaker is placed in the ON position when the disk drive is installed and remains in the ON position until the disk drive is repaired or removed.

The power-up procedure is as follows:

1. Verify that the drive is connected to the ac power source and that the circuit breakers are in the ON position.
2. Remove the front panel and set the diagnostic and unit switches (refer to paragraph 2.1.3). Replace the front panel.
3. Set the power ON/OFF switch in the ON position.

2.2.1.1 Power-up Tests - When the power ON/OFF switch is set in the ON position the drive begins the power-up test sequence by illuminating all front panel display elements (LEDs and seven-segment digital display indicators (3)). Turning on all front panel display elements facilitates a visual check for STUCK-OFF display elements. While the display element check is in progress the microECLIPSE monitors the drive for five possible shut-down statuses. The statuses are:

- POWER OFF
- SPINDLE CONTROL FAULT
- REGULATED POWER FAULT
- OVER-TEMPERATURE

If any one of these statuses are detected, the microECLIPSE CPU cancels the digital display element check function. The microECLIPSE CPU transmits a fatal error code "F" to the UNIT number digital display indicator and an error code to the STATUS digital display indicator. The error code identifies which status has forced the shut-down (refer to Figure 2-8).

If no shut-down statuses are detected, the front panel display elements are extinguished. This facilitates a visual check for STUCK-ON display elements. While this visual check is in progress the microECLIPSE repeats the monitoring progress described above.

If the drive has powered itself down, recycle the power ON/OFF switch and monitor the digital display indicator panel. If an error code can not be determined on the front panel, the LEDs on the power control PCB can be used as an aid to identify the problem. The power control PCB latches and displays on one of its LEDs any shutdown status that powers down the drive. Refer to Table 2-7 Power Control PCB LEDs.

**NOTE**

A STUCK-ON or STUCK-OFF front panel display element if not identified during the visual verification test may cause the user to select the incorrect FRU on the Front Panel Display-Error Code Listing. There are ten possible STUCK-ON/STUCK-OFF combinations that confuse the reading of the error codes. They are: (0,8) (1,7) (4,9) (5,6) (6,8) (6,b) (8,A) (6-E) and (E,F). If the display elements are defective, the front panel PCB must be replaced (refer to paragraph 5.6).

After the completion of the test for STUCK-ON and STUCK-OFF elements, and the monitoring for shut-down statuses, the 6236/6237 disk drive performs a sequence of nine tests on drive operation. As each test is in progress the microECLIPSE CPU transmits a two digit number to the STATUS digital display indicator. The numbers count down from "09" to "01" in the sequence listed in Table 2-10. Refer to Section 3 (Theory of Operation) for a detailed description of each test.

**Table 2-10. Power-up Test Sequence**

STATUS DIGITAL DISPLAY TEST NUMBER	TEST PERFORMED
09	Program ROMs and RAMs
08	FIFO and Busy Flop
07	Spindle Up-to-Speed
06	Servo Static and Dynamic Functions
05	Servo Seek Function
04	Head Select and Data Flow Ports
03	Rotational Positioning System
02	Data Hook
01	Read/Write/Read

**NOTE**

During the Spindle Up-to-Speed test (test 07), the number "07" flashes on the STATUS digital display indicator for approximately 35 seconds (until the spindle is up to the correct operational speed).

After the successful completion of each test the STATUS digital display indicator number is replaced by the next sequential test number. After the successful completion of the last test (test 01) the STATUS digital display indicator extinguishes and the READY LED illuminates.

If any test fails, the microECLIPSE CPU transmits the failing error code to the STATUS digital display indicator. The microECLIPSE either powers-down the drive or enables the drive in read-only mode (the READY LED illuminates and an error code appears in the STATUS digital display indicator).

Refer to Table 2-11 for the disk drive power-up sequence.

Table 2-11. Power-Up Sequence (ON-LINE Normal Operating Mode)

USER ACTION	DRIVE STATUS	LED SEQUENCE
Set circuit breaker in the ON position	AC power is supplied to the drive	CHECK LED illuminates on the front panel
Set SW4=OFF and SW3=OFF	Drive is set in: ON-LINE Normal Operating Mode	
Set Power ON/OFF switch in the ON position	Drive monitors for five shut-down statuses.	CHECK LED extinguishes. Front panel display elements illuminate then extinguish. Power control PCB LEDs (-15, +15, -5 and +5) illuminate.
	Drive completes shut-down status monitoring.	Power control PCB LEDs (-15, +15, -5 and +5) extinguish and (ACPWOK) illuminates.
	Drive begins power-up tests.	Power control PCB LED (SVOK) illuminates. Spindle control PCB LEDs (02) and (03) illuminate. Front panel digital display indicator begins displaying test numbers "09" to "01".
	Drive completes power-up test 07 (Spindle Up-to-Speed)	Power control PCB LED (SVOK) extinguishes. Spindle control PCB LEDs (02 and 03) extinguish.
	Drive completes final power-up test 01 Read/Write/Read	Front panel digital display indicator extinguishes (goes blank), the drive unit number is displayed on the UNIT digital display indicator. The front panel READY and UNIT LEDs illuminate.

### 2.2.2 Power-Down Procedure - The power-down procedure stops the drive's operation.

The power-down procedure is as follows:

1. Set the power ON/OFF in the OFF position.
2. Set the circuit breaker(s) in the OFF position.

### 2.2.3 Monitoring Procedure - The 6236 front panel has three (seven-segment) digital display indicators that report on the operational status of the disk drive. Refer to paragraph 2.1.4 for information on the front panel digital display indicator. The position of SW3 and SW4 on the front panel PCB affects the digital display mode. Refer to paragraph 2.1.3 for information on SW3 and SW4.

To monitor the operation of the disk drive the user must observe the digital display indicator to detect error codes and/or current cylinder. When the drive is in ON-LINE/Normal Operating Mode (SW3=OFF, SW4=OFF) the drive displays the drive unit number in the UNIT digital display indicator. If a fault is detected by the microECLIPSE it transmits an error code to the STATUS digital display indicator. Refer to Figure 2-8 for a front panel display - error code listing. The error code listing provides a description of the problem(s) detected and the most probable field replaceable unit (FRU) that has failed. Replace the first FRU listed, use the diagnostic program to verify correct drive operation. Refer to Section 4 (Fault Diagnosis) for troubleshooting information.

- Using Figure 2-8. Front Panel - Error Code Listing

For example: If the error code "A1" appears on the STATUS digital display indicator it is an indication of an OVER-TEMPERATURE condition. The possible failing FRUs are; (7) Power Control PCB, Control Logic PCB or Power Supply Assembly.

When the disk drive is in ON-LINE/Display Current Cylinder mode then the front panel digital display indicator displays the current cylinder number and the front panel error code transmission is overridden.

### 2.2.4 Emergency Conditions - The following is the procedure to perform when an emergency condition arises:

- 6236 disk drive subsystem:

If an emergency condition arises, set the Power ON/OFF switch to the 0 (OFF) position.

- 6237 disk drive subsystem:

If an emergency condition arises, set the Meter High Cabinet Power ON/OFF switch to the 0 (OFF) position.

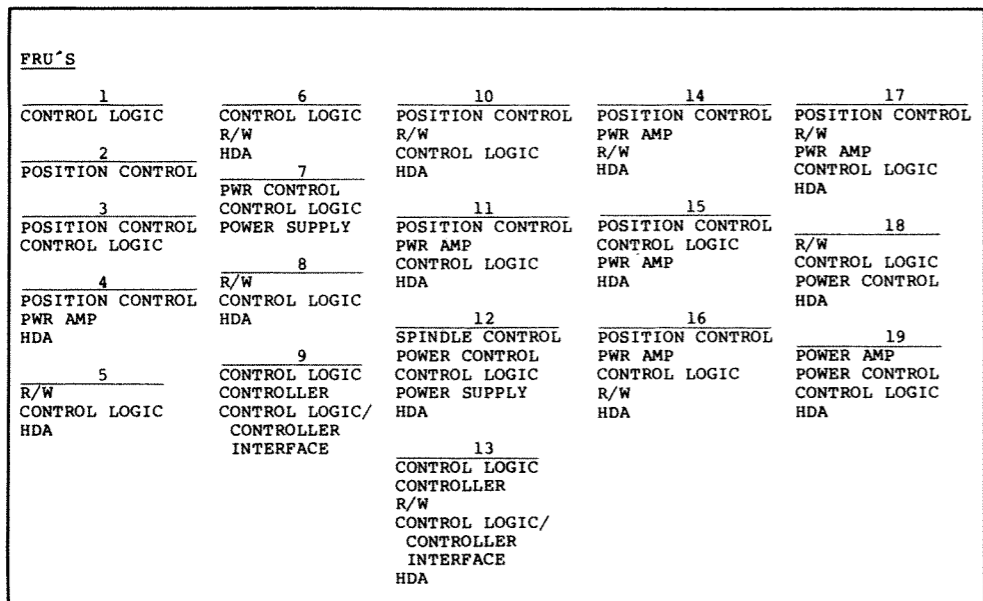

**WARNING**

DO NOT CONFUSE B'S (b) WITH 6'S (6)

**SWITCH SETTINGS**

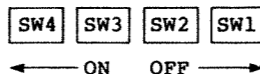

FUNCTION	SW4	SW3	SW2	SW1	UNIT
ON LINE - DISPLAY UNIT + AND ERROR CODE	OFF	OFF	OFF	OFF	0
ON LINE - DISPLAY CURRENT CYLINDER	ON	OFF	OFF	ON	1
OFF LINE - LOOP ON POWER-UP TESTS	OFF	ON	ON	OFF	2
OFF LINE - LOOP ON RANDOM SEEKS	ON	ON	ON	ON	3

IF THE OFF-LINE SWITCH IS SET TO ON WHILE THE DRIVE IS READY, THE DRIVE'S ERROR LOG IS DUMPED ONCE. ERROR CODES ARE DUMPED STARTING WITH THE MOST RECENT.

**6236/6237 ERROR CODES & FRU LISTS REV. 0**

ERR CODE	FRU LIST	DESCRIPTION
20	9	RD/WR OP:CHK PT 0:COMMAND/DATA PULSED COMMAND
21	6	RD/WR OP:CHK PT 0:SYNC ON HEADER ACTIVE TOO SOON
22	13	RD/WR OP:CHK PT 0:HDR/DATA=DATA DURING HEADER
23	6	RD/WR OP:CHK PT 0:SYNC ON DATA ACTIVE TOO SOON
24	6	RD/WR OP:CHK PT 0:HEADER OK ACTIVE TOO SOON
25	13	RD/WR OP:CHK PT 0:RD/WR ERROR REPORTED BY R/W PROCESSOR
26	9	RW/WR OP:CHK PT 1:COMMAND/DATA PULSED COMMAND
27	6	RW/WR OP:CHK PT 1:FORMATTING ERROR:HDR SYNC ACTIVE
29	6	RW/WR OP:CHK PT 1:SYNC ON DATA ACTIVE TOO SOON
2A	6	RW/WR OP:CHK PT 1:FORMATTING ERROR:HDR OK ACTIVE
2B	13	RW/WR OP:CHK PT 1:RD/WR ERROR REPORTED BY R/W PROCESSOR
2C	9	RD/WR OP:CHK PT 2:COMMAND/DATA PULSED COMMAND
2D	13	RD/WR OP:CHK PT 2:FORMATTING ERROR:HDR SYNC ACTIVE
2F	6	RD/WR OP:CHK PT 2:NO SYNC ON DATA
30	6	RD/WR OP:CHK PT 2:NO HEADER OK
31	13	RD/WR OP:CHK PT 2:RD/WR ERROR REPORTED BY R/W PROCESSOR

ERR CODE	FRU LIST	DESCRIPTION
33	6	DATA HOOK:CHK PT 0:SYNC ACTIVE TOO SOON
35	6	DATA HOOK:CHK PT 0:SYNC ON DATA ACTIVE
37	6	DATA HOOK:CHK PT 0:RD/WR ERROR REPORTED BY R/W PROCESSOR
38	6	DATA HOOK:CHK PT 0:FIFO IN NOT READY
39	6	DATA HOOK:CHK PT 0:FIFO OUT NOT READY
3B	6	DATA HOOK:CHK PT 1:SYNC ON HOOK DATA NOT ACTIVE
3D	6	DATA HOOK:CHK PT 1:SYNC ON DATA ACTIVE
3F	6	DATA HOOK:CHK PT 1:RD/WR ERROR REPORTED BY R/W PROCESSOR
40	6	DATA HOOK:CHK PT 1:FIFO IN NOT READY
41	6	DATA HOOK:CHK PT 1:FIFO OUT READY
50	9	ILLEGAL CONTROLLER COMMAND BYTE READ FROM FIFO
51	9	CHECKSUM ERROR ON CONTROLLER COMMAND PARAMETERS
52	9	TIMEOUT:RECEPTION OF CONTROLLER'S COMMAND PARAMETERS
53	9	TIMEOUT: TRANSMISSION OF DRIVE'S STATUS PARAMETERS
56	9	CYLINDER OUT OF RANGE
57	9	SECTOR OUT OF RANGE
58	9	REQUEST TO FORMAT WITHOUT BEING IN DIAGNOSTIC MODE
59	9	ILLEGAL TYPE OF READ/WRITE OPERATION SPECIFIED
5A	9	TIMEOUT CONTROLLER'S START OF R/W OPERATION
5B	9	CONTROLLER INTERRUPT ALREADY ACTIVE
5C	9	RD/WR OP ERROR:DATA MODE ACTIVE AFTER R/W TERMINATED
5D	9	PARITY ERROR
60	8	READ/WRITE POWER FAULT
61	8	RD/WR:SERVO AGC FAULT
62	8	RD/WR:HEAD SELECT FAULT
63	8	RD/WR:SERVO CLOCK FAULT
64	18	RD/WR:WRITE CURRENT FAULT
65	8	RD/WR:POSITION DECODER FAULT
67	8	RD/WR:DATA CLOCK FAULT
68	8	PROTECT STATUS WENT ACTIVE DURING A WRITE/FORMAT
69	8	NO PROTECT STATUS RETURNED BY RD/WR PCB
6A	8	TIMEOUT:SECTOR PULSE
6B	8	"SECTOR VALID":FAILED TO SHOW VALID
6C	8	NEW BLOCK WRITE/FORMAT WHILE DRIVE IN PROTECT
70	16	DYNAMIC TEST: NO DIG P SIGNAL
71	16	DYNAMIC TEST: NO DIG Q SIGNAL
72	16	DYNAMIC TEST: NO LIN P SIGNAL
73	16	DYNAMIC TEST: NO OFF TRK SIGNAL
74	16	SEEK: COARSE SEEK TO FINE SEEK TIMEOUT
75	16	SEEK/DYNAMIC TEST: TRACK PULSE HOLD TIMEOUT
76	16	SEEK/RECAL: FINE SEEK TO ON-TRACK TIMEOUT
77	16	RECAL: TIMEOUT
78	4	SEEK: COARSE SEEK DIRECTION ERROR
79	4	RECAL: DIRECTION ERROR
7A	14	DYNAMIC TEST: CARRIAGE UP TO SPEED TIMEOUT
7B	15	STATIC TEST: NOT IN LZ/IGB
7C	10	DYNAMIC TEST: BAD VELOCITY CALIBRATION
7D	10	SEEK/RECAL: WRONG SERVO SURFACE CODE
7E	11	RECAL/DYNAMIC/STATIC TEST: POSITION DISABLE STATUS ERROR
7F	4	SEEK/RECAL: TRACK FOLLOW SETTLE TIMEOUT
80	5	RECAL: BAD SERVO SURFACE CODE
81	5	SEEK/RECAL/STATIC TEST: SERVO SURFACE CODE NOT READY
82	5	STATIC TEST: SERVO SURFACE CODE IS GARBAGE
83	3	A/D CONVERSION ERROR
84	3	STATIC TEST: TRK PLS HOLD LATCH RESET ERROR
85	3	SEEK/STATIC/DYNAMIC TEST: LDTG=1 LATCH SET/RESET ERROR
86	3	STATIC TEST: VELOCITY REFERENCE DIAGNOSTIC READ ERROR
87	3	STATIC TEST: SERVO ERR DIAGNOSTIC READ ERROR
88	3	STATIC TEST: SEEK PATH DIRECTION ERROR
89	3	DYNAMIC TEST: PHASING ERROR
8A	3	DYNAMIC TEST: DST ERROR
8B	4	SEEK RECAL: FINE SEEK MAXIMUM VELOCITY ERROR
8C	4	SEEK/RECAL: DESTINATION OVERSHOOT

ERR CODE	FRU LIST	DESCRIPTION
8D	4	RECAL: MAXIMUM VELOCITY EXCEEDED
8E	2	SEEK: COARSE SEEK TO FINE SEEK ENTRY PHASE ERROR
8F	2	SEEK/RECAL: TRACK FOLLOW PHASE ERROR
90	2	RECAL: RECAL TRACK PHASE ERROR
91	2	DYNAMIC TEST: VELOCITY REFERENCE ERROR
92	4	SEEK EXERCISER: LAST TEST NOT ON RECAL TRACK
93	17	PWR-UP'S WAIT FOR INR GRD BAND TIMEOUT
94	17	TRACK FOLLOW: OFF TRACK
95	17	TRACK FOLLOW: WR OP NOT STARTED DUE TO OFF TRACK
96	17	RW-PU-TST: UNABLE TO CONFIRM POSITION ON DIAG TRAC
A0	7	POWER OFF
A1	7	OVER-TEMPERATURE
A2	7	REGULATED POWER FAULT
A3	19	SERVO POWER FAULT
A4	12	SPINDLE SPEED FAULT
A5	12	SPINDLE CONTROL FAULT
A6	12	AC POWER FAIL
A7	12	TIMEOUT: SPINDLE UP TO SPEED
B0	1	CHECKSUM ERROR AT "39-W", PART #4263
B1	1	CHECKSUM ERROR AT "46-W", PART #4262
B2	1	CHECKSUM ERROR AT "36-W", PART #4265
B3	1	CHECKSUM ERROR AT "44-W", PART #4264
B4	1	WRONG ROM(S) IN THE CSROMLO SOCKET(S)
B5	1	ALL EPROMS NOT OF THE SAME REV LEVEL
B6	1	MARCH TEST ERROR LO BYTE OF RAM "34-W"
B7	1	MARCH TEST ERROR HI BYTE OF RAM "41-W"
B8	1	ADDRESS TEST ERROR ON RAMS
B9	1	DISABLE OUTS FLOP STUCK ON
BA	1	FIFO SUB-SYSTEM:RESET: FIFO IN NOT READY
BB	1	FIFO SUB-SYSTEM:RESET: FIFO OUT READY
BC	1	FIFO SUB-SYSTEM:WRITE: IN NOT READY
BD	1	FIFO SUB-SYSTEM:WRITE: OUT NOT READY
BE	1	FIFO SUB-SYSTEM:WRITE LAST: IN READY
BF	1	FIFO SUB-SYSTEM:READ: IN NOT READY
C0	1	FIFO SUB-SYSTEM:READ: OUT NOT READY
C1	1	FIFO SUB-SYSTEM:READ LAST: FIFO OUT READY
C2	1	FIFO SUB-SYSTEM:READ/WRITE: BAD COMPARE
C3	1	BUSY SET WITHOUT FIFO OUT RDY BEING SET
C4	1	READ/WRITE CONTROL PORT TEST FAILED
C5	6	RD/WR CONTROL PORT TEST: R/W ERROR FAILED TO SET
C6	6	TIMEOUT CHANGE ON DATA FLOW/DIAGNOSTIC PORTS
C7	1	READ/WRITE ERROR FAILED TO CLEAR
C8	6	HEAD CONTROL PORT TEST FAILED
C9	6	BAD COUNT ON SECTOR COUNTER
CA	6	ROT. POS. TEST: BAD TIMING BETWEEN SECTOR COUNTS
CB	6	DATA HOOK: BYTE READ NOT EQUAL TO BYTE WRITTEN
CC	6	RW-PU-TST: RESET COUNT VALUE INCORRECT
CD	6	RW-PU-TST: WRITE OPERATION FAILED
CE	6	RW-PU-TST: INDETERMINATE, CAN'T RD&WT PROT INHBS WR
CF	6	ROT. POSITION TEST: TIMEOUT SECTOR 55
D0	6	RW-PU-TST: DEAD HEAD
D2	1	MICRO-ECLIPSE STACK FAULT
D3	1	ATTEMPT TO SEEK WITH DATA FLOW IN WRITE MODE
D4	1	NO INTERRUPT STATUS RETURNED FROM INTERFACE
D5	1	INITIATE SEQUENCE NOT YET IMPLEMENTED
D6	1	ILLEGAL VALUE IN CURRENT MODE REGISTER
D7	1	UNEXPLAINABLE SOFTWARE PHENOMON
D8	6	TIMEOUT: PRE-TARGET SECTOR
D9	6	SYNC NOT DETECTED ON HDR DURING A RD/WR OPERATION
DA	6	RD/WR OP: TIMEOUT CHANGE ON SECTOR COUNT BITS
DB	6	RD/WR OP: R/W PROCESSOR SAYS: READ/WRITE ERROR
DC	6	RD/WR OP ERROR: TIMED OUT INDEX
DD	6	TIMEOUT SECTOR VALID DURING A RD/WR OPERATION

Figure 2-8. Front Panel Display - Error Code Listing



## 2.3 OPERATOR MAINTENANCE

The 6236 disk drive subsystem is equipped with a coarse air filter that is installed on a VELCRO strip on the front cover. The coarse air filter cleans the air that enters the closed-loop air cooling system. It must be cleaned once per month. If the filter is damaged it must be replaced (DGC #002-11044).

### CAUTION

Damage to the disk drive will occur if the disk drive is operated without the coarse air filter installed on the front cover or if the drive is operated with a contaminated coarse air filter.

The procedure for removing and/or cleaning the coarse air filter is as follows:

1. Depress the two tabs on the sides of the front panel assembly and remove the panel from the chassis (refer to Figure 2-9).
2. Carefully peel the coarse air filter off the Velcro strip on the front cover.
3. Clean the filter in clean water, allow the filter to dry before installing it on the front cover.
4. Install the filter on the VELCRO strip on the front cover. Position it correctly.
5. Install the front panel.

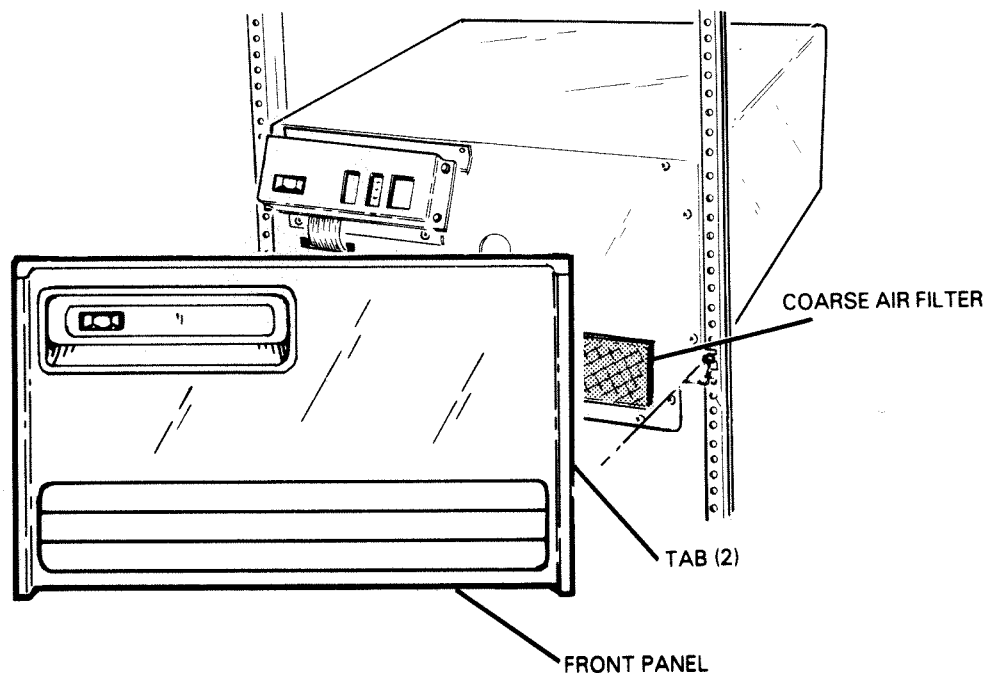

FS-07112

Figure 2-9. Coarse Air Filter

### SECTION 3

#### THEORY OF OPERATION

This section describes the theory of operation for the 6236/6237 disk drive subsystem. It contains sections on architectural, functional and operational theory.

##### 3.1 ARCHITECTURAL THEORY

The 6236 disk drive subsystem consists of a CPU-resident controller PCB and a rack mounted FCC compliant (FCC-c) chassis (refer to Figure 3-1). The 6237 disk drive subsystem consists of three 6236 disk drives installed in a stand-alone Meter High Cabinet.

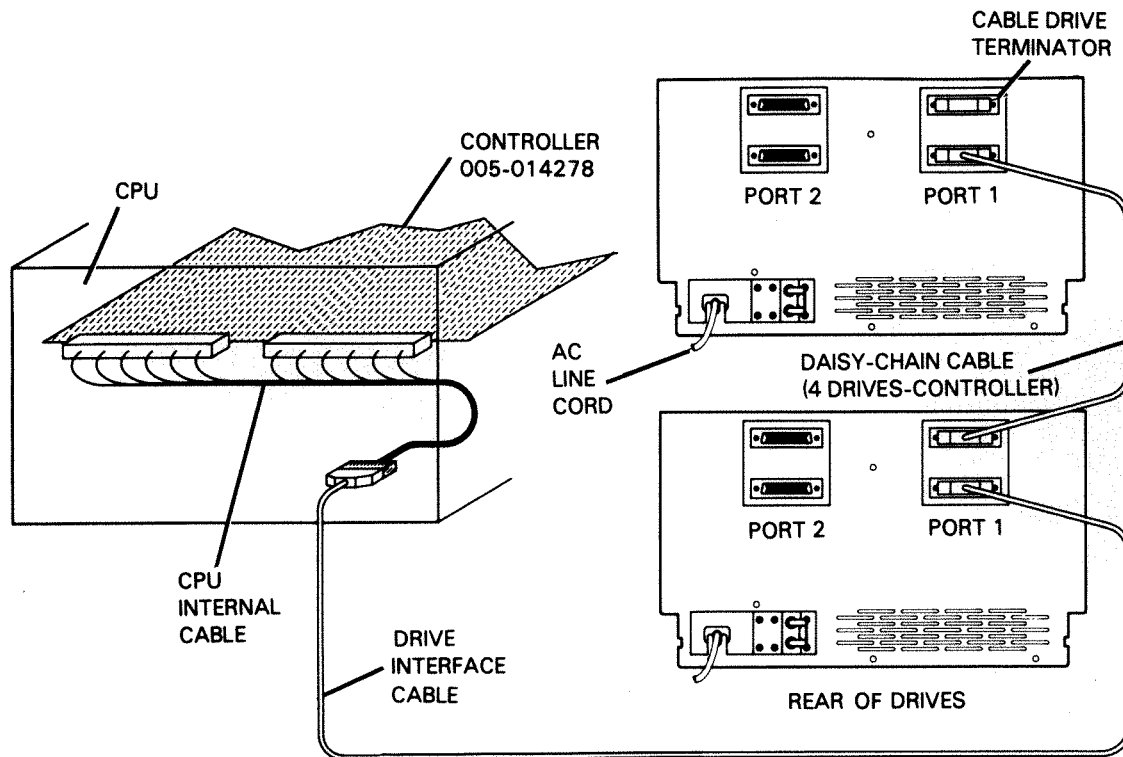

Figure 3-1. 6236 Disk Subsystem Connected to a CPU

The rack mounted FCC-c chassis contains the following major components (refer to Figure 3-2):

- Disk Functional PCBs
- Head Disk Assembly (HDA)
- Front Panel PCB
- Power Supply Assembly
- Cabling

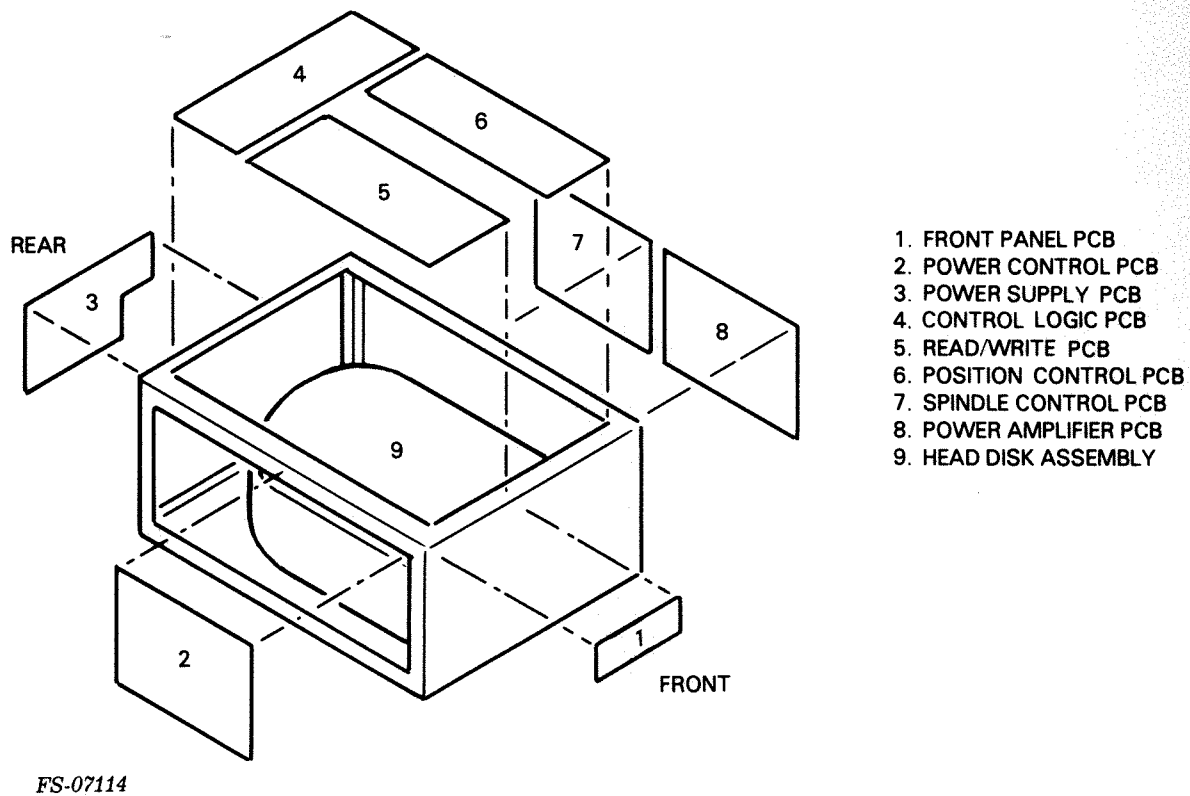

Figure 3-2. 6236 HDA and PCBs

3.1.1 Disk Function PCBs - A functional description of each PCB shown in Figure 3-2 is given in section 3.2.2 - Functional Theory, Major PCBs.

3.1.2 Head Disk Assembly (HDA) - The HDA is a sealed metal container which houses no field serviceable parts. The following description helps to understand the operation of the disk drive.

#### CAUTION

Do not remove the cover of the sealed HDA. This will cause contamination of both the heads and the recording media.

The HDA contains the following items shown schematically in Figure 3-3:

- Linear Motor
- Carriage Assembly
- Read/Write (R/W) Heads
- Servo Head
- Spindle Motor and External Spindle Blower
- Recording Media
- External Spindle Blower
- Clean Air System (via an absolute and breather filters)

The function of the linear motor is to drive the carriage assembly, which has the R/W and servo heads attached to it, across the recording media. The linear motor receives drive current from a control loop, which begins at the control logic PCB (refer to Figure 3-4). The control logic PCB supplies cylinder difference data to the position control PCB, which converts the information to an error signal for the power amplifier, producing a high level current to drive the linear motor. The motion is sensed by the servo read-only head. The R/W PCB processes the servo head information and routes the position signal through the control logic PCB to the position control PCB, which monitors the carriage displacement and adjusts the power amplifier output current to drive the carriage to the destination cylinder.

Data General Corporation (DGC) has prepared this manual for use by DGC personnel and customers as a guide to the proper installation, operation, and maintenance of DGC equipment and software. The drawings and specifications contained herein are the property of DGC and shall neither be reproduced in whole or in part without DGC's prior written approval nor be implied to grant any license to make, use, or sell equipment manufactured in accordance herewith.

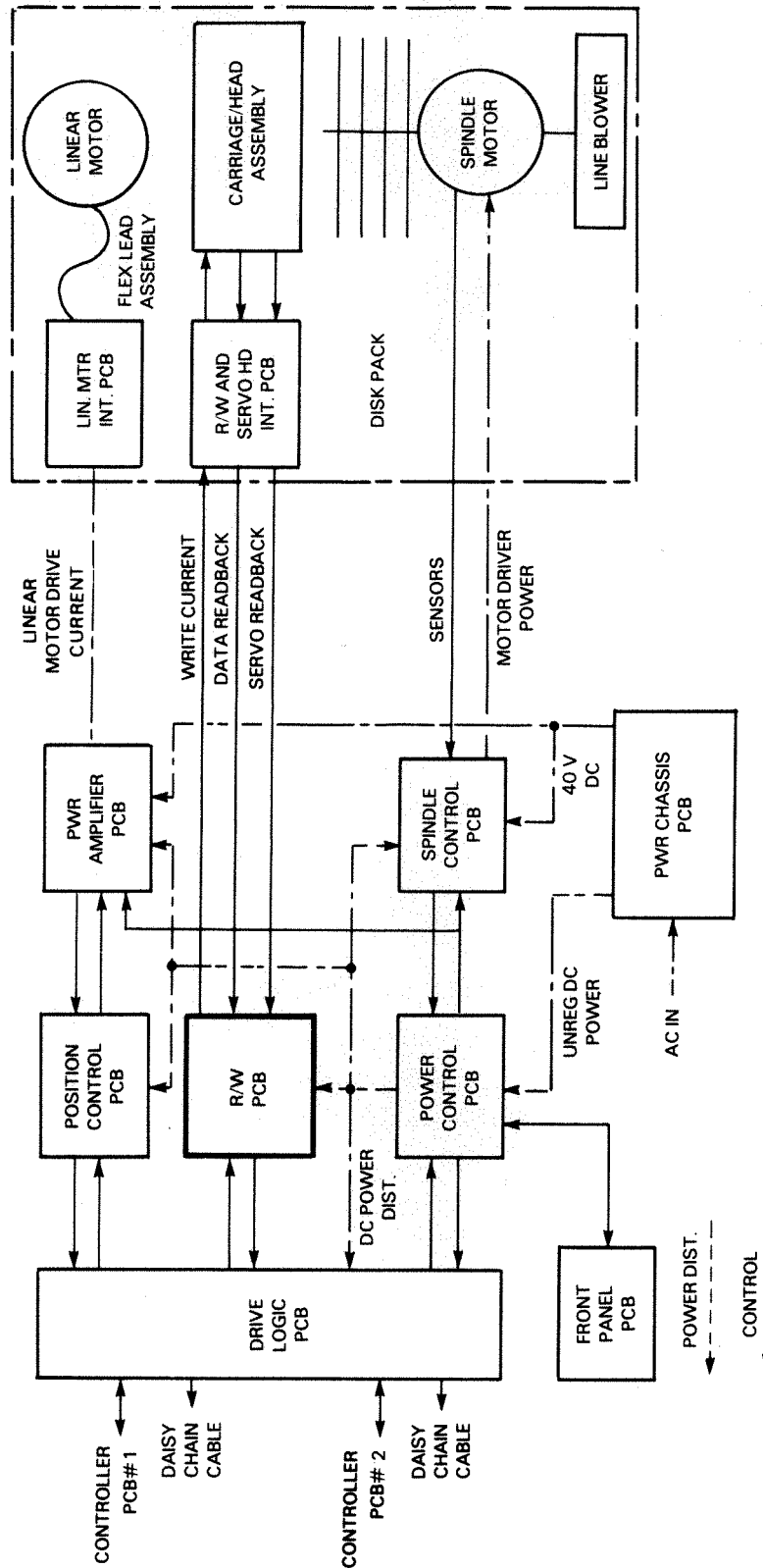

Figure 3-3. Drive Schematic Block Diagram

FS-07115

Data General Corporation (DGC) has prepared this manual for use by DGC personnel and customers as a guide to the proper installation, operation, and maintenance of DGC equipment and software. The drawings and specifications contained herein are the property of DGC and shall neither be reproduced in whole or in part without DGC's prior written approval nor be implied to grant any license to make, use, or sell equipment manufactured in accordance herewith.

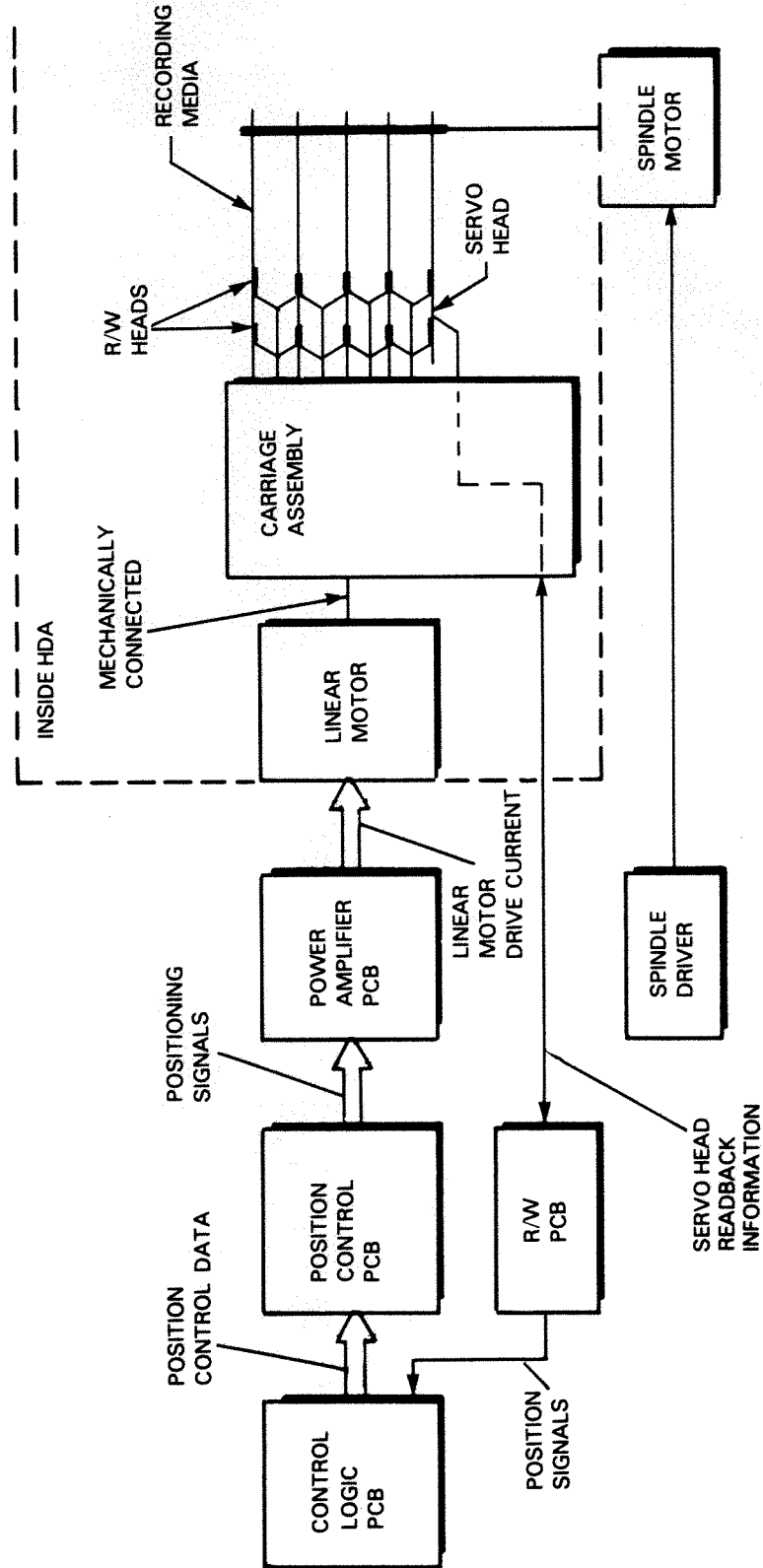
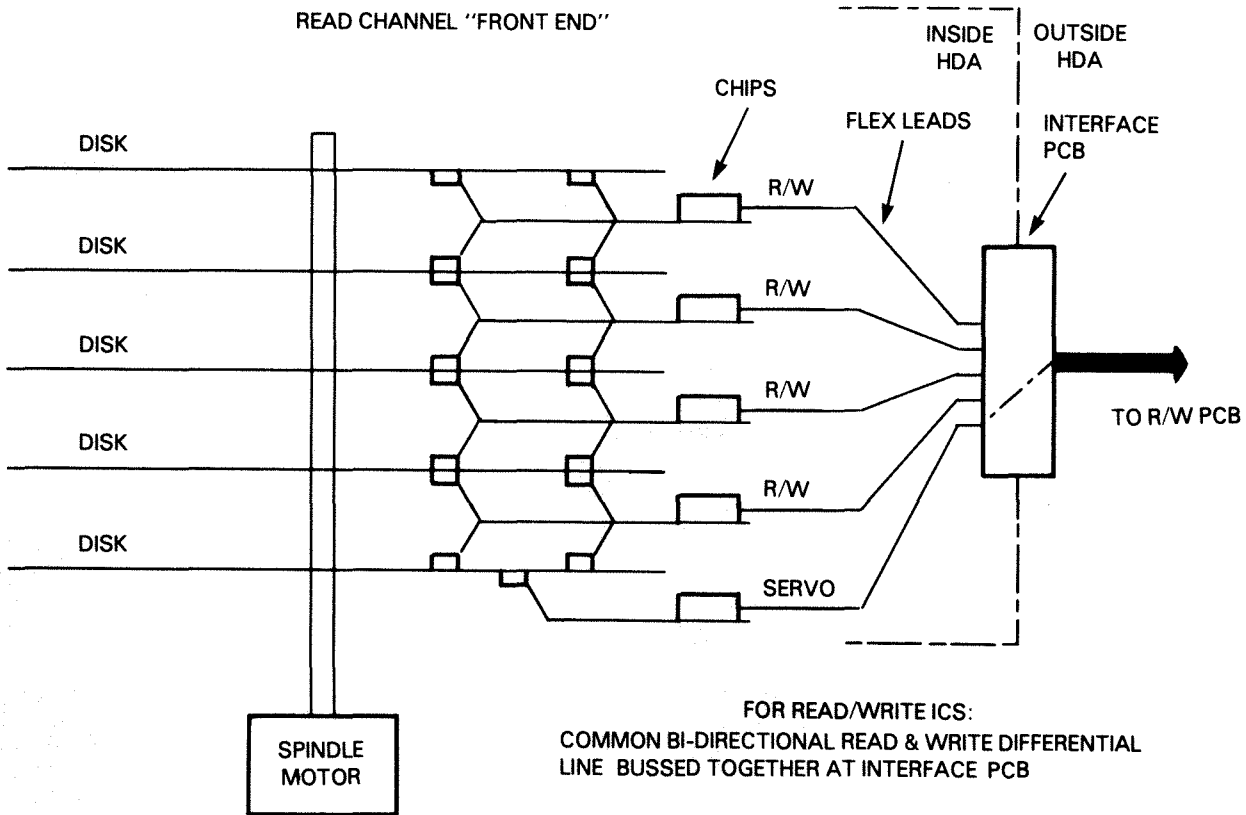

Figure 3-4. Linear Motor Signal Chain

The recording media for the 6236 disk drive consists of five disks that are attached to the shaft of the spindle motor. For writing and reading, all surfaces of the disks are used except the top of the top disk and the bottom of the bottom disk, making eight surfaces available. Positioner information is on the bottom surface of the bottom disk.

The R/W heads (refer to Figure 3-5) are used to record or retrieve data from the recording media. There are four quad R/W head assemblies (for a total of 16 R/W heads) within the disk drive and one servo (read only) head. Each head/arm assembly contains a preamplifier to maintain a high signal to noise ratio at the input to the R/W PCB.



FS-07117

Figure 3-5. R/W and Servo Heads

The function of the servo head is to read position information from a dedicated prerecorded servo surface. The servo head reads this information from the bottom of the fifth disk (refer to Figure 3-5). Like the R/W Heads, the servo head is physically attached to an arm of the carriage assembly and is connected, via a flex lead, to the module interface PCB. The interface PCB (internal to the sealed HDA) contains a feed thru plug which will connect the servo head to the servo channel of the R/W PCB via a flat ribbon cable.

The function of the spindle motor is to supply a constant 3000 RPM rotation of the recording media. The five disks are attached to the shaft of the spindle motor. On the external shaft of the spindle motor (on the bottom and outside of the HDA) there is a blower assembly which provides a continuous circulation of air within the 6236 disk drive. The spindle motor receives power and is constantly monitored by the spindle control PCB.

The HDA is sealed at the factory in an ultra-clean environment. The HDA maintains this clean environment by circulating the internal air, by the rotation of the disks, and passing it through an absolute filter. A breather filter allows the disk to "breathe" during start-up and thermal changes. This closed-loop air system insures that there will be no contamination of either the heads or the recording media.

3.1.3 Front Panel PCB - The functions of the front panel PCB are to provide the disk drive's ON/OFF switch with supply status and fault information, and to provide the unit number on request. The front panel PCB (refer to Figure 3-6) consists of a power ON/OFF switch, five LEDs (labeled RDY, PRO, CHK, UNIT, and STATUS), three seven-segment digital display indicators and five switches (representing an ON/OFF switch, two diagnostic switches, and two unit select switches).

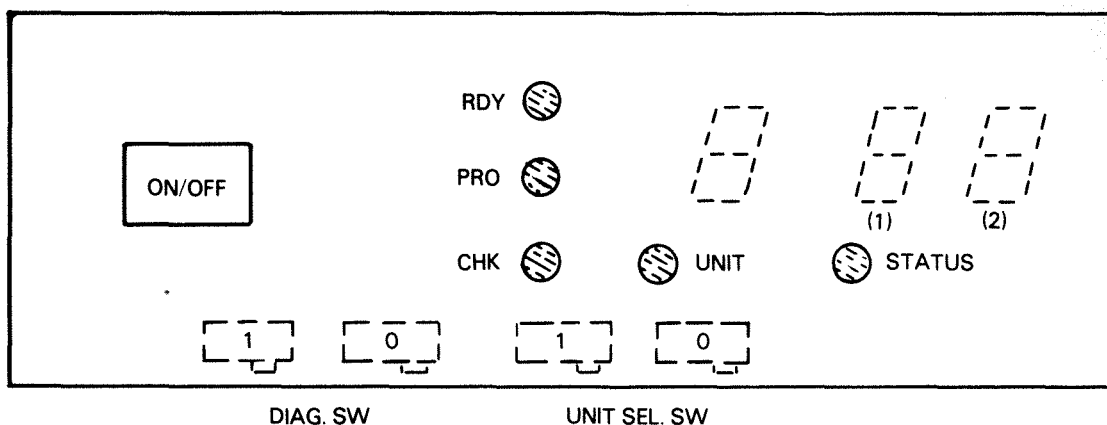

FS-07118

Figure 3-6. Front Panel PCB



The front panel PCB (refer to Figure 3-7) consists of the front panel switches (DEV SEL 0, DEV SEL 1, DIAG 0, DIAG 1, and ON/OFF), the front panel LEDs (CHK, RDY, PRO, UNIT, and STATUS), three seven-segment digital display indicators and an ON/OFF switch.

FRONT PANEL BLK DIAGRAM

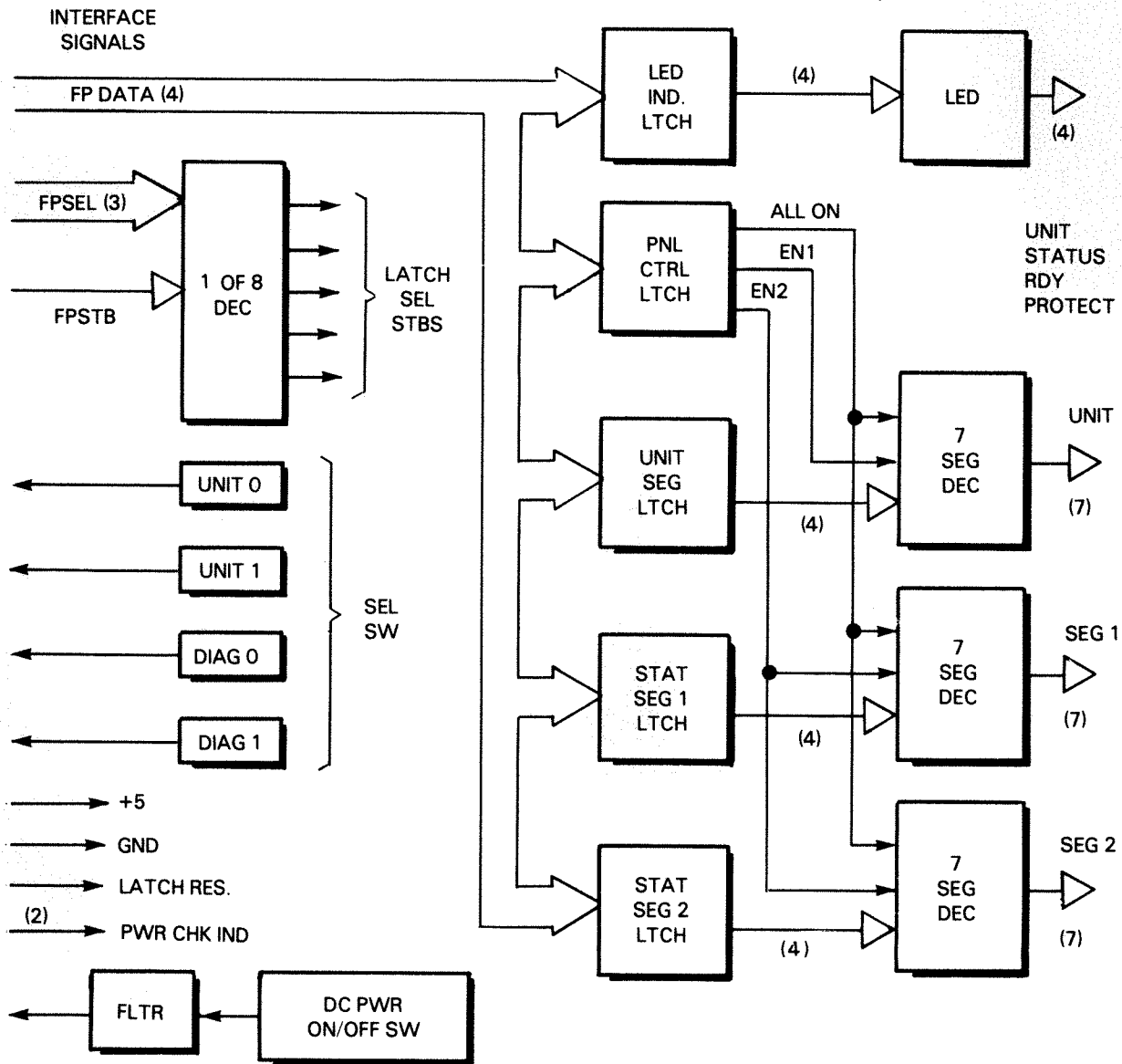

FS-07119

Figure 3-7. Front Panel PCB Block Diagram

The ON/OFF switch controls the dc power in the disk drive.

The RDY LED illuminates when the drive completes its power-up diagnostics to indicate that the drive is capable of communication to the host CPU via the drive's controller PCB (resident in the CPU).

The PRO LED illuminates to indicate that the control logic PCB is in a write protect mode. Write protect can be issued by a switch on the R/W PCB (refer to 3.2.2.1) or by detection of a hard error.

The CHK LED illuminates when the dc power within the drive is interrupted. When the power ON/OFF switch is in the ON position, the power control PCB supplies the dc voltages to the drive and extinguishes the CHK LED. While the drive is running, the CHK LED will illuminate when any dc error is detected, which will indicate a hard error and terminate operations of the disk drive.

The UNIT LED is associated with the left-most seven-segment digital display indicator. When this LED illuminates, the number in the left-most seven-segment digital display indicator is the unit number of the drive.

The STATUS LED only illuminates when the drive detects an error and normal operation is interrupted (certain soft errors can be handled by the control logic PCB and the CPU-resident controller PCB). When this LED illuminates, the right two seven-segment digital display indicators may display, conditioned by the diagnostic switches, a hex number, which is a fault code (for a definition of all fault codes, refer to Section 4).

Under normal operating conditions, the three seven-segment digital display indicators are used to display other information depending on how the diagnostic switches are set.

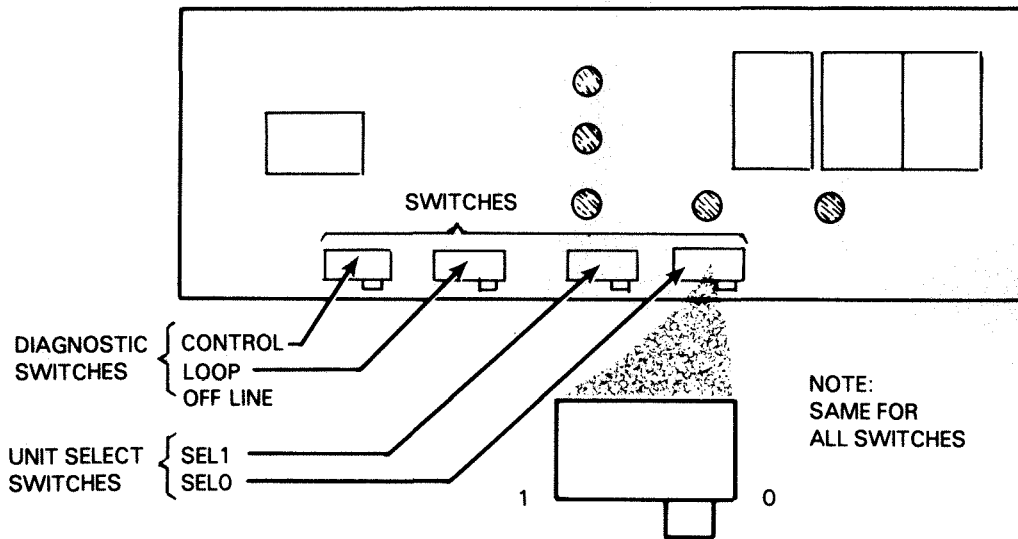

FS-07120

**Figure 3-8.** Front Panel PCB Switch Selections

For a further definition of the front panel switches and LEDs. (Refer to Section 2 or Model 6236/6237 Operator's Guide (Data General Part Number 014-701000)).

3.1.4 Power - The dc power for the 6236 disk subsystem is distributed from the power supply and the power control PCB (refer to Figure 3-9).

3.1.4.1 The Power Supply Assembly - The power supply assembly is located at the rear of the disk drive and contains a bulkhead ac entrance assembly which contains an ac line filter and an ac circuit breaker (CB). The power supply PCB supports all power supply components with the exception of the ferroresonant transformer (XFMR) and its capacitor (CAP).

The power supply is wired for worldwide operation and uses a jumper configuration for voltage and frequency selection. The jumpering is accomplished by two plugs on the back of the power supply PCB (for proper jumpering information refer to Section 6).

The ac line coming into the power supply PCB is split into two paths (refer to Figure 3-10). One path is a fused ac which produces 24 AUX used by the power control PCB. This 24 AUX is always energized no matter what the position of the front panel ON/OFF switch as long as ac power is applied.

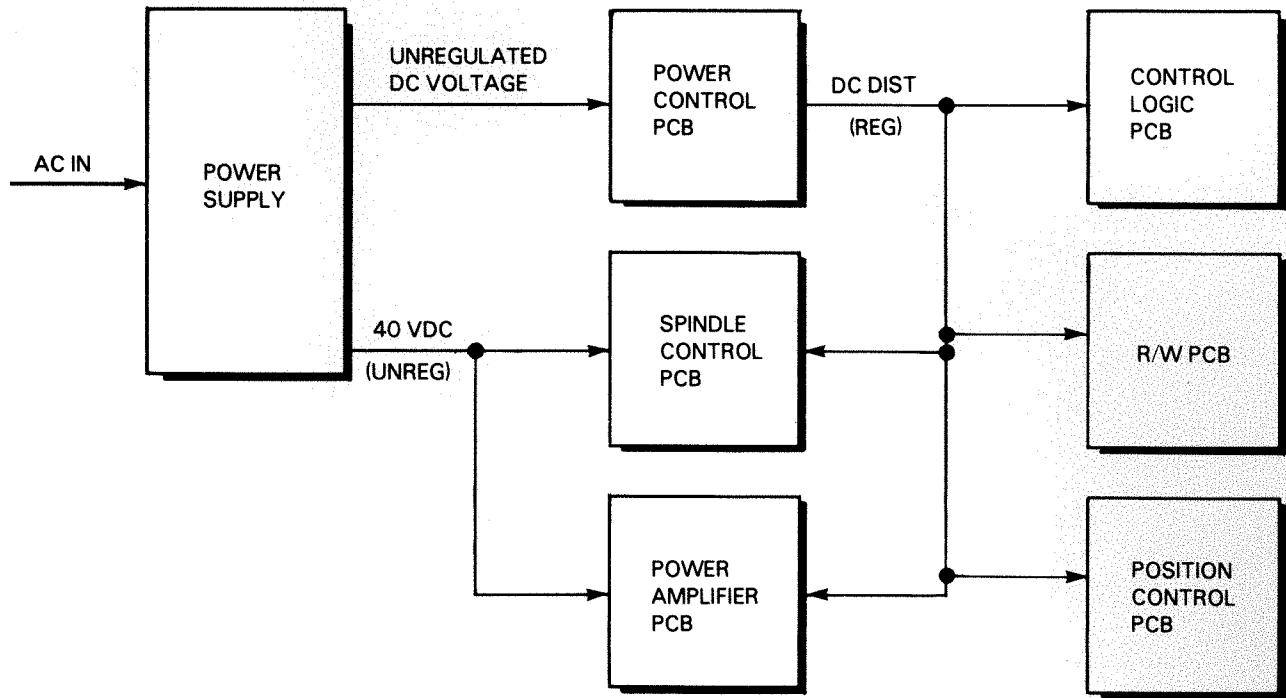

FS-07121

Figure 3-9. DC Power Distribution

Data General Corporation (DGC) has prepared this manual for use by DGC personnel and customers as a guide to the proper installation, operation, and maintenance of DGC equipment and software. The drawings and specifications contained herein are the property of DGC and shall neither be reproduced in whole or in part without DGC's prior written approval nor be implied to grant any license to make, use, or sell equipment manufactured in accordance herewith.

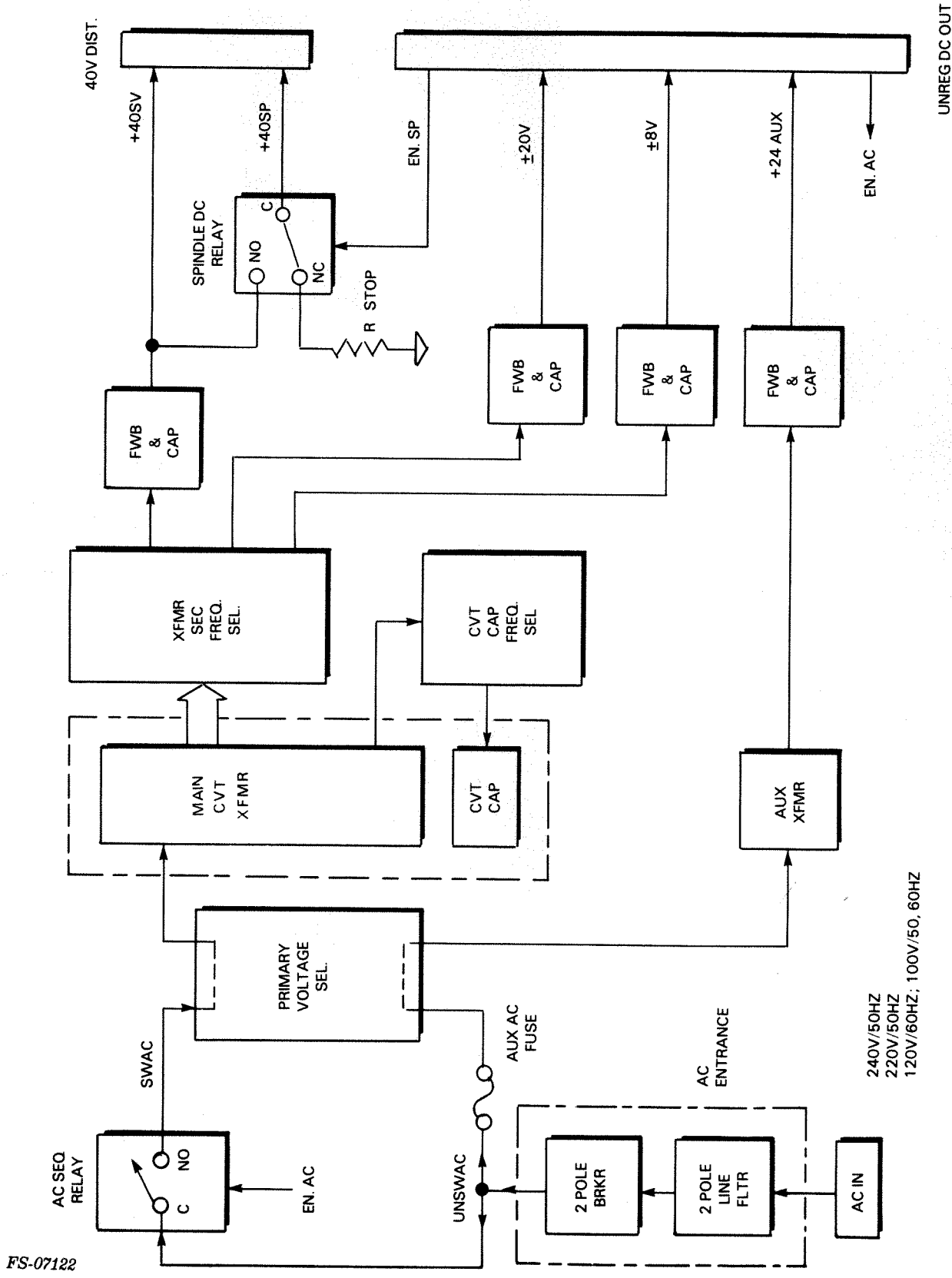

FS-07122

Figure 3-10. Power Supply Assembly Block Diagram

The other path goes to an ac relay, which is activated in response to a signal called AC EN generated from the power control PCB. From the relay, the voltage is stunted (via a voltage jumper configuration) to provide required worldwide configuration of the ferroresonant transformer. This transformer has three secondaries:

- +40Vdc unregulated
- +/-20Vdc unregulated
- +/-8Vdc unregulated

For a 50/60 Hz operation with a universal ferroresonant supply, secondaries must be tapped for frequency. This is accomplished via connectors for the 50 and 60 Hz output taps and the 50 and 60 Hz ferroresonant capacitor taps. Mating (jumper) plugs are used to select either 50 or 60 Hz operation.

The proper selected secondaries are fed to their respective full wave bridge and filter capacitors. The unregulated dc is routed to the output connectors. The unregulated +/-8 and +/-20Vdc go to the power control PCB. The +40 SV goes to the power amplifier PCB and to another relay on the power supply PCB called spindle relay. The spindle relay is activated by a signal called SPIN EN generated on the power control PCB, and produces +40 SP which is supplied to the spindle control PCB. When not energized, the relay provides a dynamic brake for the stopping of the spindle.

3.1.4.2 The Power Control PCB - The power control PCB (refer to Figure 3-11) consists of the +/-5V regulator, the +/-15V regulator, the +5V auxiliary regulator, the +15V auxiliary regulator, a monitor system, and a LED display. This PCB provides two functions:

- Generates all drive major regulated voltages; and,
- Monitors and displays the state of the regulated voltages and functions critical for system operations.

Data General Corporation (DGC) has prepared this manual for use by DGC personnel and customers as a guide to the proper installation, operation, and maintenance of DGC equipment and software. The drawings and specifications contained herein are the property of DGC and shall neither be reproduced in whole or in part without DGC's prior written approval nor be implied to grant any license to make, use, or sell equipment manufactured in accordance herewith.

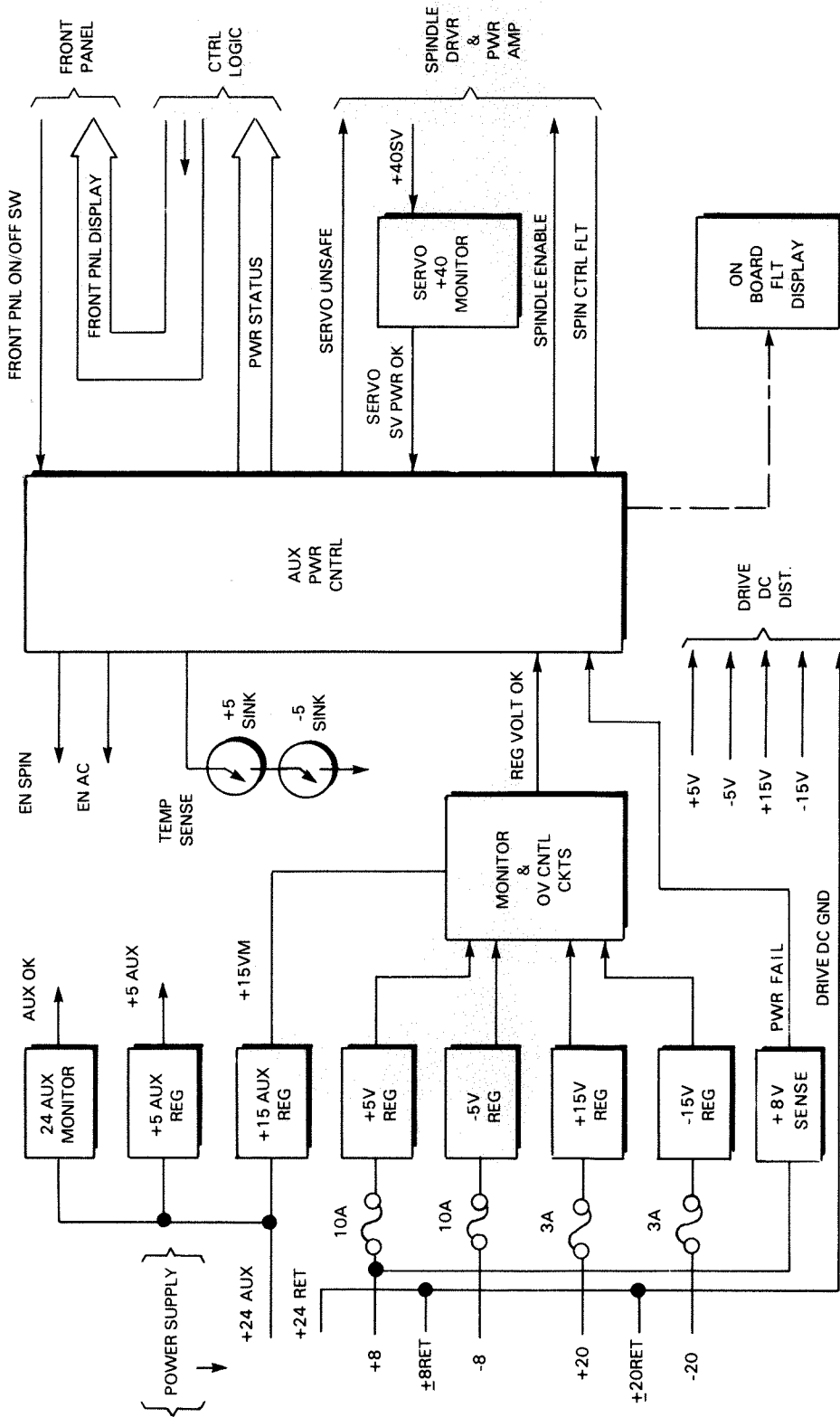

Figure 3-11. Power Control PCB Block Diagram

FS-07123

The regulated voltages are generated from the +/-8 and +/-20 raw voltages supplied from the power supply PCB. Each line of the +/-8V are protected by a 10 amp fuse and each line of the +/-20V are protected by a two amp fuse. The following regulated voltages are produced:

- +5V +/-2% at 8 amps from +8V nominal
- -5V +/-2% at 6 amps from -8V nominal
- +15V +/-3% at 1 amp from +20V nominal
- -15V +/-3% at 1 amp from -20V nominal

The outputs provide the +/-5V and +/-15V regulated dc power distribution for the drive. The outputs of the regulated voltages are monitored for under and over-voltage.

Each regulated voltage is critical, the loss of any will sequence power-off. This is necessary since the spindle control system that drives the spindle motor contains an integral blower used to cool all PCBs. The loss of any control voltage to the spindle motor would also mean loss of cooling to the drive. The loss of cooling would produce a fatal over-temperature in a rack mounted environment if the dc power remained on.

This PCB monitors each regulated voltage as well as the auxiliary 24V, the position control power amplifier 40V, and over-temperature of the drive. All systems that are monitored are visually displayed by the following LEDs:

- +5V
- -5V
- +15V
- -15V
- Spindle Control Fault
- OVERTEMP
- AC PWR OK
- SV PWR OK (indicates position control power amplifier 40V is present)

3.1.5 Cabling - The overall drive interconnection diagram is shown in Figure 3-12. For a description of individual cables refer to section 4.



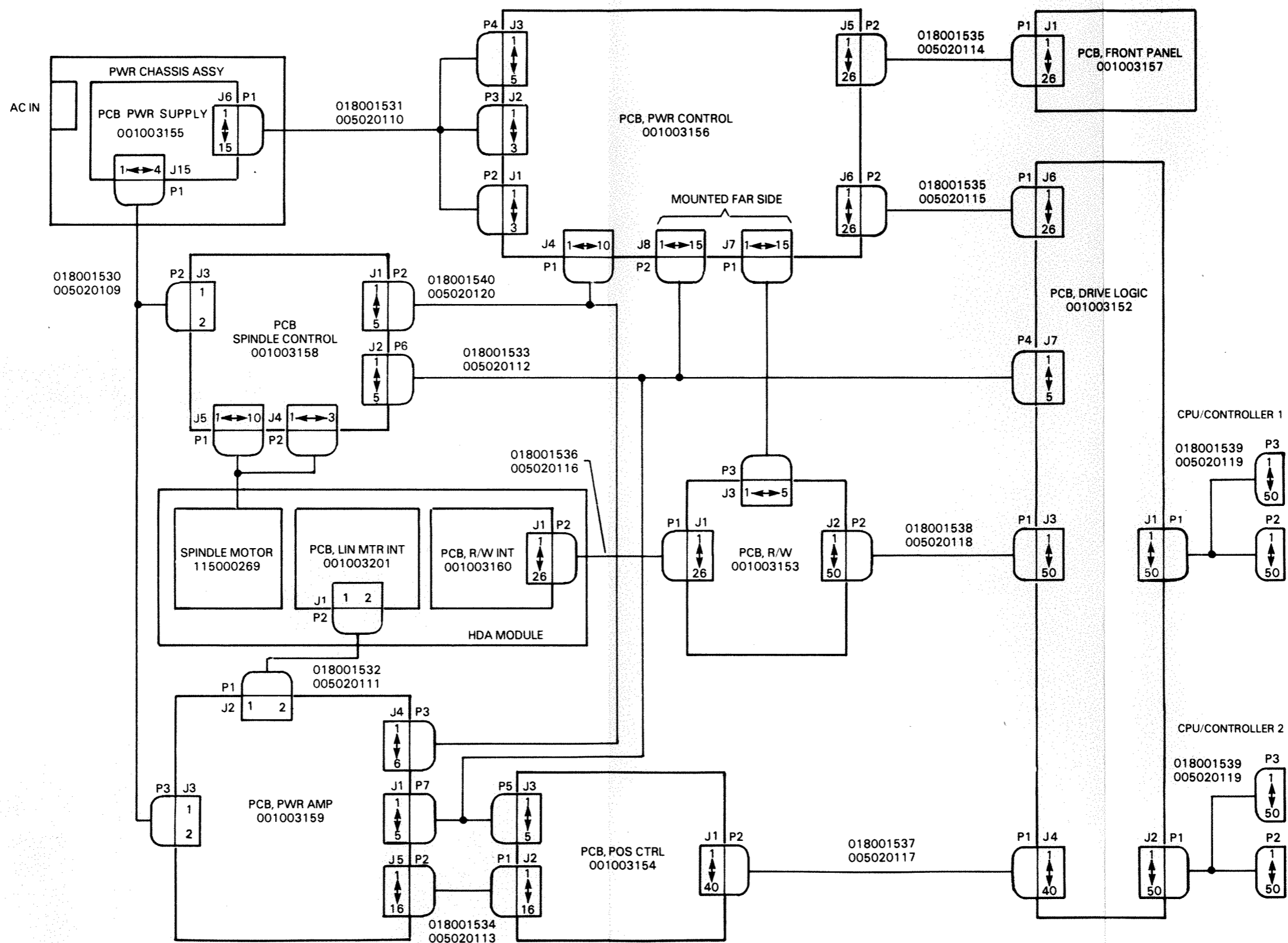

FS-07124

Figure 3-12. 6236  
Interconnection Diagram  
015-000137  
3-17/3-18

## 3.2 Functional Theory

This section describes the functional theory of the controller PCB and the disk function PCBs.

**3.2.1 Controller PCB** - The 6236 controller is a fifteen by fifteen inch multilayer (six layers - four signal, one power, and one ground) PCB that plugs into the standard backpanel of a host CPU. The controller PCB provides an interface between the 6236 disk drive and the host CPU. The controller PCB has the capability of supporting four 6236 disk drives or up to 1.5 Gigabytes of storage.

The controller PCB communicates with the host CPU over two busses:

- A burst multiplexor channel interface (BMCI) for the controller's high disk data transfer rates of 1-2 Mb/sec.
- A data channel (DCH) for programmed I/O (PIO) transfers.

The controller PCB (refer to Figure 3-13) is a high performance microprocessor (6809) driven controller. The microprocessor is controlled (programmed) by the microcode which is stored in a programmable read only memory (PROM) resident on the PCB. The controller PCB communicates with the host CPU via either a PIO bus or a BMCI bus. The controller communicates to the 6236 disk drive via a COMMAND/DATA bus.

The controller PCB interfaces with the disk drive through a 50-pin bulkhead connector. All lines of the cable to the disk drives are differentially driven, providing electrical isolation between the host CPU and the disk drive. The data interface between the controller PCB and the 6236 disk drive is an eight bit bi-directional bus whose control is shared by the controller PCB's 2901 based microprocessor and the control logic PCB's R/W Processor.

The intelligence interface, using the 6809 microprocessor, allows the controller to off-load other functions that were previously performed at the disk driver software level. These functions include automatic retry on error (the number of retries is programmable), 17 bit error correction, and self-diagnostics. In addition, the controller PCB has the capability to perform defective sector skipping.

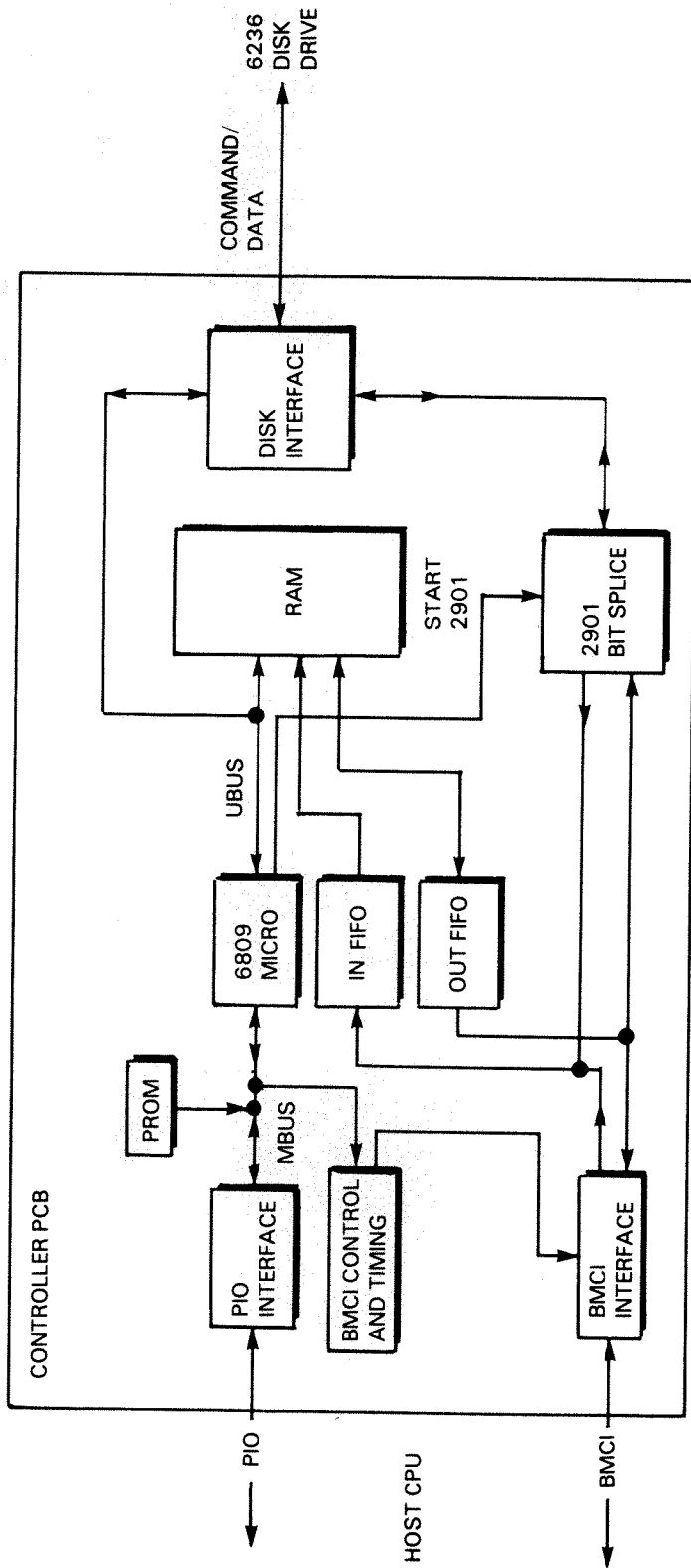
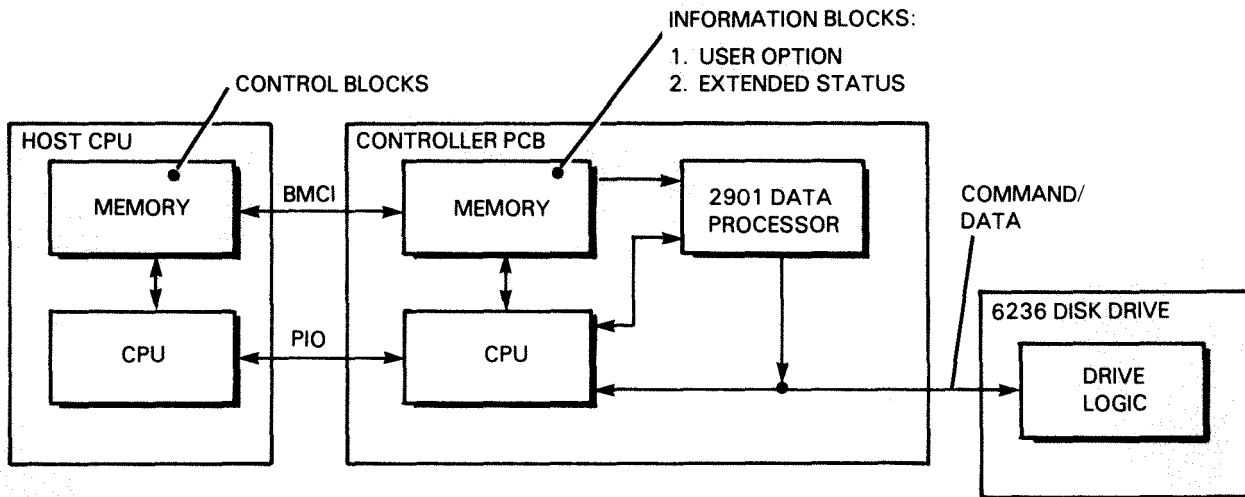

Figure 3-13. 6236 Controller PCB Block Diagram

The controller PCB self-diagnostics are resident on the controller PCB and are software driven. Operator PIO commands will instruct the controller PCB to run certain tests. The self-diagnostics test the following:

- Sequencer FIFOs
- Modified Bit RAMs
- ALU
- XEQ 2901 Sequence
- Sequencer
- Interrupts
- Microcode PROM Checksum
- Error Flip-flop
- Disk Interface FIFOs
- Address Counter
- Transfer Counter
- Burst Length Compare PROMs
- Command Registers
- Command/Data Bus
- Control Tag Bus
- ECC Registers
- Sector Buffer and FIFOs

To understand the operation of the controller PCB, the structure of how the controller sends and receives commands/data to the host CPU must be understood (refer to Figure 3-14). In an unintelligent disk drive, all drive and controller tasks are initiated by the device driver programs resident in the host CPU memory; but, the 6236 controller has its own intelligence and can perform many of these tasks itself. The operator sends PIO commands that perform controller operations. The PIO commands control the operation of the controller PCB and instruct the start of a drive operation included in the Control Block (CB). If the PIO commands instruct a start of a CB list (a number of linked CBs), the controller intelligence can fetch other commands and data by itself, without interrupting the host CPU. (The controller only interrupts the host CPU when a CB list is completed or the controller PCB encounters a hard error from the disk drive or itself).



FS-07126

Figure 3-14. Controller to Disk Data Transfers

The operator uses PIO commands to communicate between the host CPU and the controller and CBs to program operation of the disk drive (i.e., read, write, how much data to transfer). Control block commands consist of a set of commands that use two special data structures for transmitting commands, data, and status information.

- COMMAND BLOCKS which specify drive operations and data transfers
- INFORMATION BLOCKS which specify drive and controller options and status information when an error occurs

A control block is a user-defined block stored in the host CPU memory. It gives the controller all the information it needs to perform a disk drive operation (i.e., operation code, how much data to transfer, etc.). When the operations of the control block are complete, the controller writes return status and error information into the control block. The operator can access this information and take the necessary action.

Control blocks can be linked together to form a control block list. The controller is informed where the first control block is located, continually fetching all control blocks without interrupting the host CPU. The controller interrupts the host CPU when the list is complete or encounters an error.

There are two types of information blocks which are stored in the controller memory and retrieved by the host CPU via I/O instructions:

- User Option
- Extended Status

User option information blocks define the following three options:

- Controller options, which specify the number of controller retries for soft errors.
- Interface options, which specify universal information the host CPU needs to know about a device.
- Unit options, which specify universal and device-specific information about a device.

Extended status information blocks are used to inform of errors. If an error occurs during controller or disk drive operation, the controller writes the status information into its own registers and into the extended status information block. The extended status information block will also supply information on specific error correction.

3.2.2 Disk Function PCBs - There are five PCBs that support the functions of the 6236 disk drive: the Control Logic PCB, the R/W PCB, the Position Control PCB, the Power Amplifier PCB, and the Spindle Control PCB (refer to Figure 3-15).

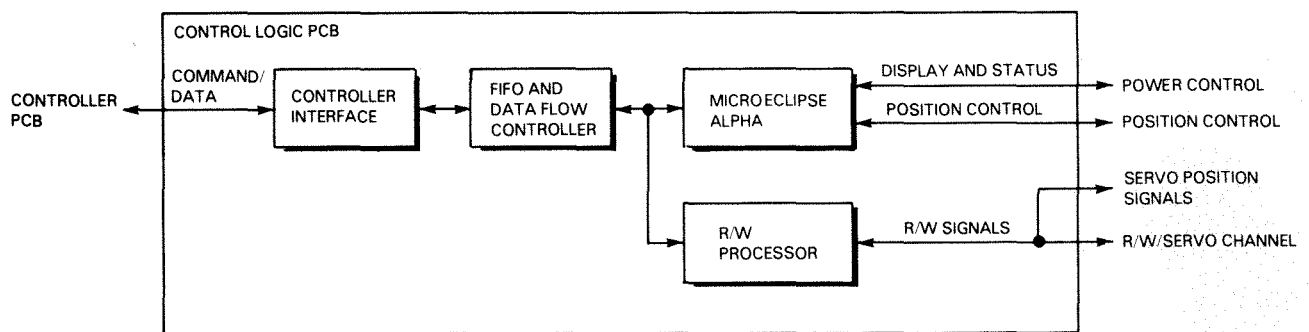

FS-07127

Figure 3-15. 6236 Disk Drive Major PCBs

3.2.2.1 The Control Logic PCB - The control logic PCB provides four functions:

- Communication to the host CPU via the 6236 controller PCB
- Read/Write (R/W) processing
- Continuous drive control and status monitoring
- Disk-drive diagnostics

The control logic PCB (refer to Figure 3-16) consists of four functional blocks:

- Controller interface
- FIFO and data flow controller
- microECLIPSE
- R/W processor

Data General Corporation (DGC) has prepared this manual for use by DGC personnel and customers as a guide to the proper installation, operation, and maintenance of DGC equipment and software. The drawings and specifications contained herein are the property of DGC and shall neither be reproduced in whole or in part without DGC's prior written approval nor be implied to grant any license to make, use, or sell equipment manufactured in accordance herewith.

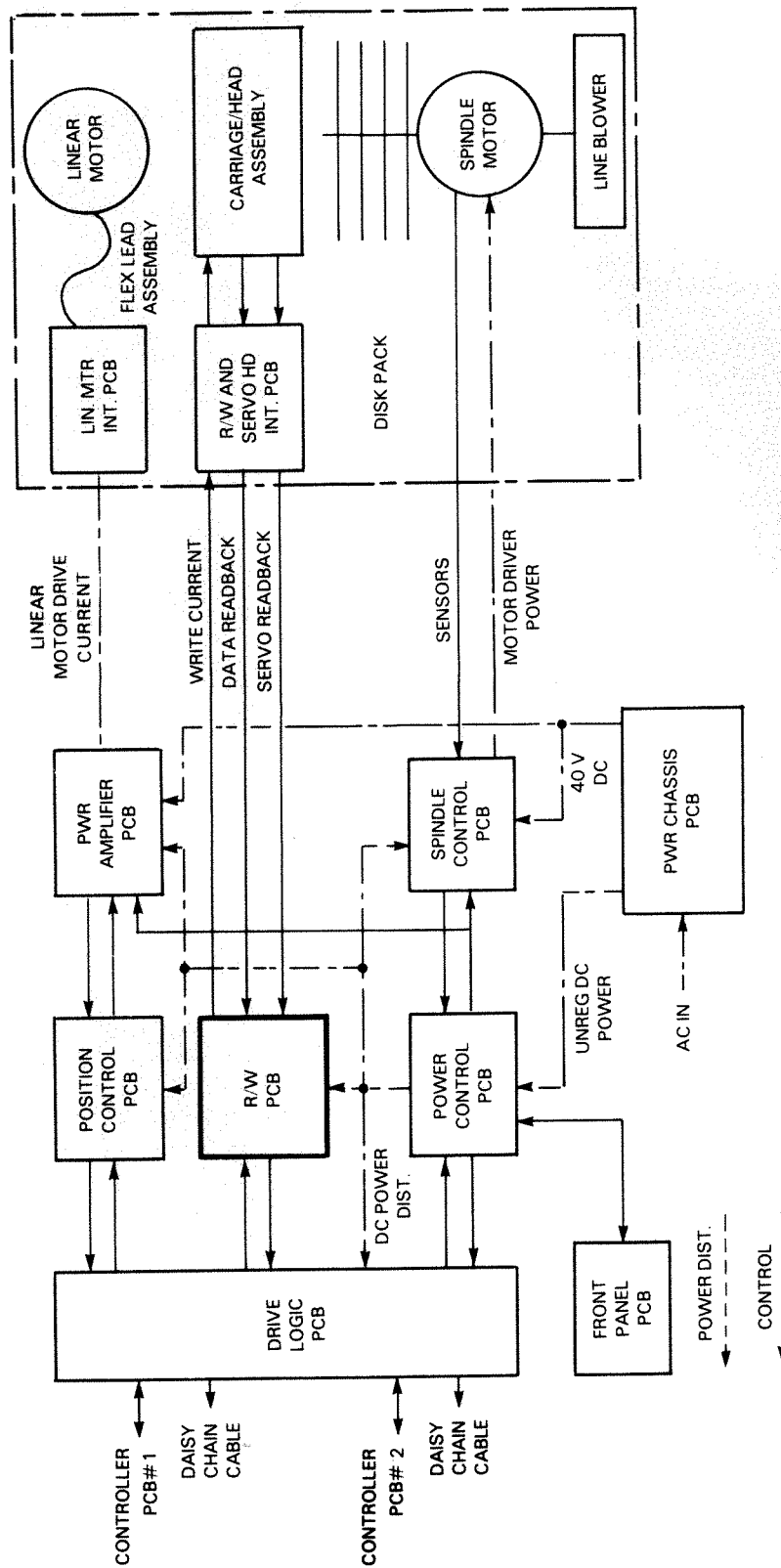

Figure 3-16. Drive Logic PCB Block Diagram

FS-07115



The controller interface receives control and transmits status to and from the controller PCB via the COMMAND/DATA bus. The interface provides communications with the controller PCB for both the microECLIPSE and R/W processor. The interface implements the command/data/tag functions for disk drive operations.

The FIFO is the central node of a network that includes the microECLIPSE, the controller interface and the R/W processor. The data flow controller arbitrates which of three units (microECLIPSE, controller interface or R/W processor) has control of the data in the control logic PCB. The data flow controller has two modes: command mode and data mode. The mode is controlled by the microECLIPSE. If the microECLIPSE has the data flow controller in command mode, it also determines whether the controller interface or microECLIPSE may load or unload the FIFO. If the microECLIPSE has the data flow controller in data mode, the R/W processor determines whether the controller interface or the R/W processor may load or unload the FIFO.

The microECLIPSE supports the functions that the control logic PCB performs. Input and output ports implement the control and status monitoring for both on-board and off-board systems. The on-board systems under the control and status monitoring of the microECLIPSE include the R/W processor, the FIFO, and the controller interface. The off-board systems under the control and status monitoring of the microECLIPSE include the position control, read/write status, power status and front panel control. The microECLIPSE also supervises the power-up diagnostics, which are resident in microECLIPSE program memory.

The R/W processor is used for R/W data processing. The R/W processor receives a control word from the microECLIPSE, bus data from the controller interface and a byte count from internal logic. With this data the R/W processor will control the internal timing and the data flow controller. When the R/W processor receives the proper timing and status signal from the R/W channel PCB, the R/W processor will encode/decode the data. The encoder/decoder function of the R/W processor does all the RLL encoding or decoding, the parallel to serial or serial to parallel conversion, and the unloading or loading of the FIFO, depending on whether the operation is a write or a read.

3.2.2.2 The R/W Channel PCB - The R/W channel PCB provides an interface for the R/W and servo heads on the carriage assembly in the HDA to the control logic and the position control PCBs. All the analog and clock systems to drive the R/W and servo channels are on this PCB.

The R/W PCB (refer to Figure 3-17) has two major functions:

- R/W Data Channel
- Servo Channel

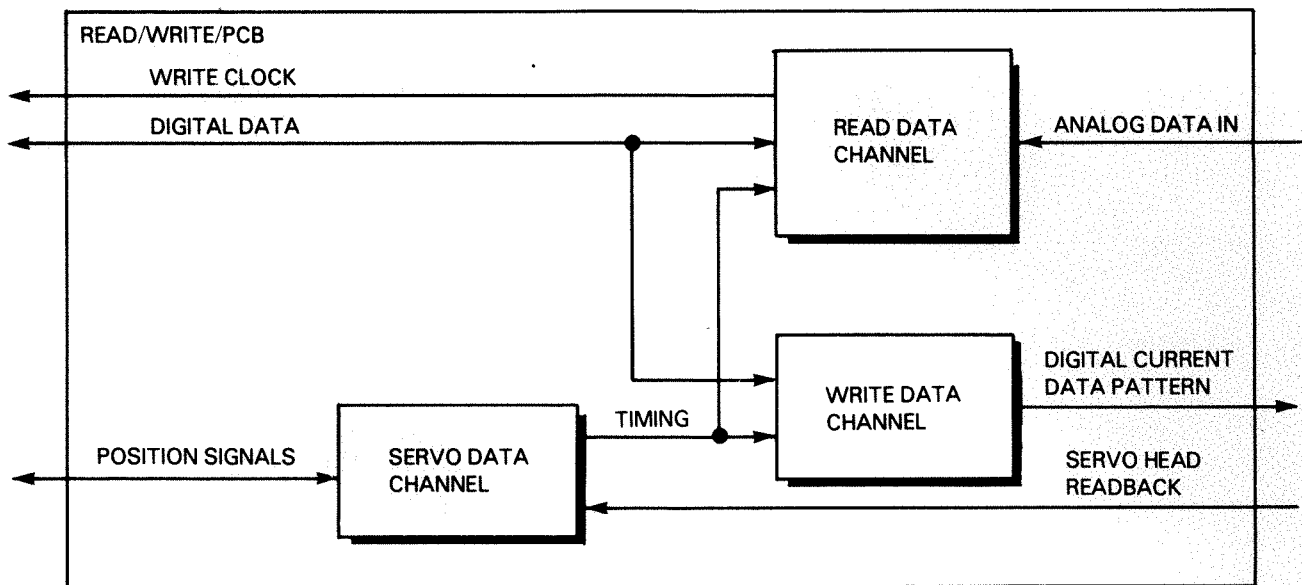

FS-07128

Figure 3-17. R/W PCB Block Diagram

The R/W data channel operates in either write or read mode according to instructions received from the R/W processor on the control logic PCB. In write mode, serial write data from the control logic PCB is translated into write current and transmitted to the R/W heads in the HDA to be recorded on the disk. In the read mode, the data that is on the disk is translated from analog readback to serial read data and sent to the R/W processor on the control logic PCB.

The servo channel is used by the control logic and the position control PCBs to locate where the heads are on the disk. The servo channel provides a read-only function from a dedicated pre-recorded surface on the bottom of the fifth recording disk in the HDA. Readback from the servo head is processed to provide a linear position signal to the position control PCB to move the heads to any position on the disks.

The R/W/Servo Channel provides the control logic PCB with comprehensive fault status of the R/W data and servo channels.

3.2.2.3 Position Control PCB - The position control PCB controls all positioning of the carriage head assembly in the HDA. The position control PCB provides the following three functions:

- Recalibrate - go to a designated cylinder on the servo surface to establish an absolute position
- Seek - go from the present cylinder to the destination specified by the 6236 controller PCB
- Track follow - maintain position on data cylinder center

The position control PCB (refer to Figure 3-18) consists of a logic interface and positioner circuitry. The logic interface is a simple buffered address-data interface from microECLIPSE on the control logic PCB. The positioner circuitry takes the input from the logic interface and the servo position signals and performs the directed positioning operation; either recalibrate, seek or track follow. The positioner circuitry generates an error signal to the power amplifier which provides the current needed to accelerate or decelerate the linear motor to perform the desired operation.

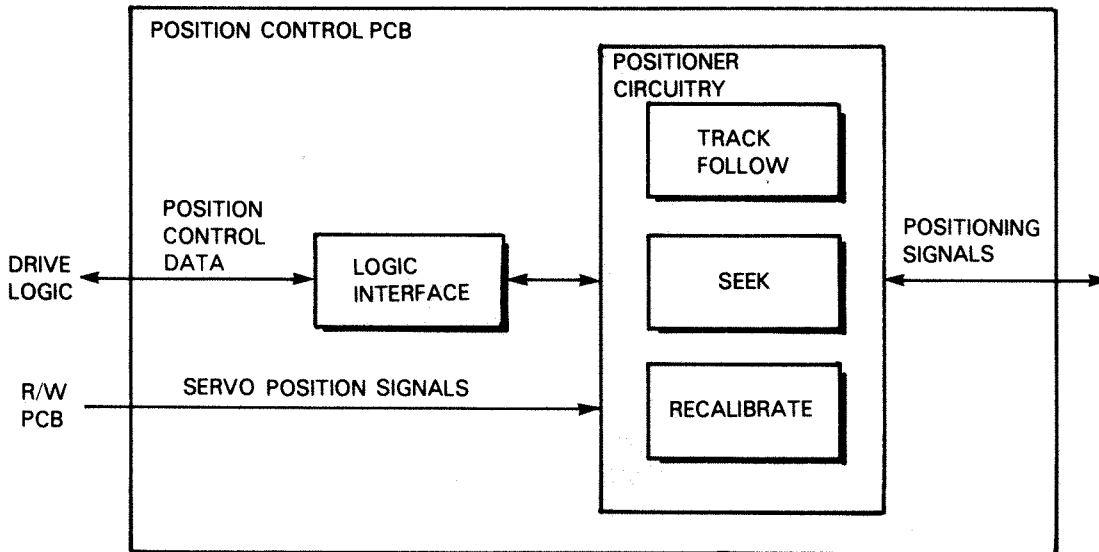

FS-07129

Figure 3-18. Position Control PCB Block Diagram

3.2.2.4 Power Amplifier PCB - The primary function of the power amplifier PCB is to convert the output of the position control PCB into a high level current for controlling the acceleration and deceleration of the linear motor in the HDA.

The power amplifier PCB (refer to Figure 3-19) consists of current control circuitry, servo unsafe circuitry, and a LED display. The current control circuitry receives its power directly from the power supply PCB via the +40 SV/+40 SP cable. This line is protected by a 6 amp fuse. The current control circuitry receives positioning signals via the positioning signal data cable from the position control PCB. The positioner signals are converted to the correct current to drive the linear motor. If a fault occurs in the positioning system or the power control, the servo unsafe circuitry will disable the current control and inform the power control PCB via the spindle control cable. If a fault does occur, a LED will illuminate to indicate that the servo system is disabled. During disable mode, the disable circuits will output a small current through M1 and M2 to force the carriage assembly into the landing zone region of the disks. This region is located at the innermost cylinders of the spindle and is not meant for data.

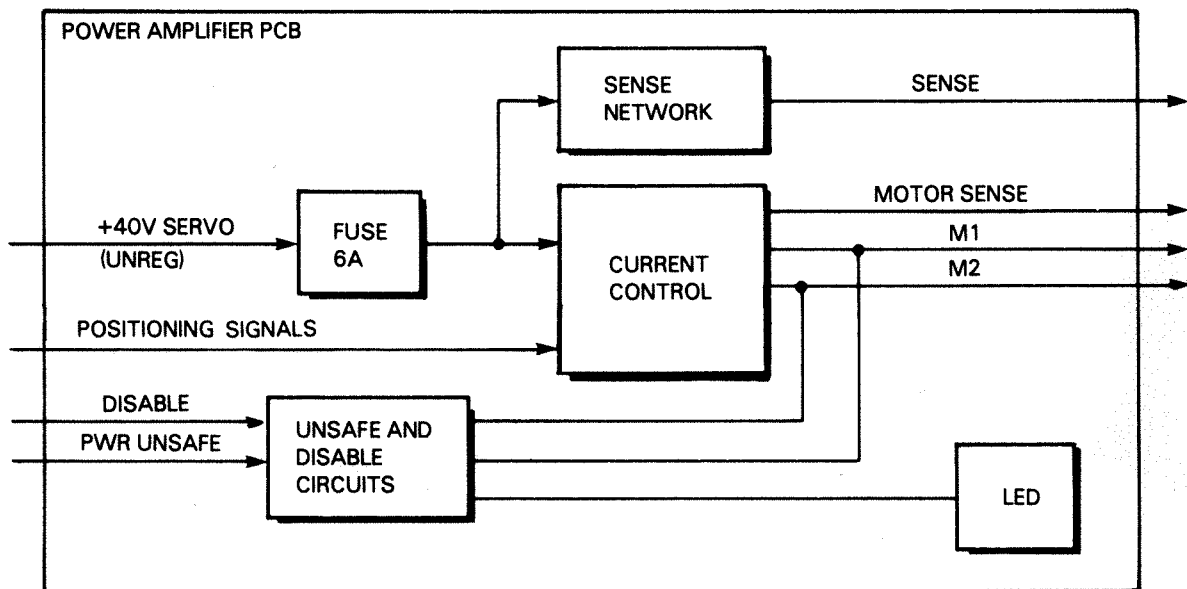

FS-07130

Figure 3-19. Power Amplifier PCB Block Diagram

3.2.2.5 Spindle Control PCB - The spindle control PCB is a closed-loop control system for the dc brushless motor driving the spindle. The spindle control PCB controls the acceleration during spindle turn on and monitors the rotational speed of the disk. Spindle status is reported to the logic unit on the control logic PCB via the power control PCB.

The spindle control PCB (refer to Figure 3-20) consists of the spindle motor control circuitry and a LED display. The primary power for the spindle motor control comes directly from the power supply PCB via the +40 SV/+40 SP cable, which is protected by a 10 amp slow blo fuse. The primary signals to control the spindle motor come from the power control PCB via the spindle/power amplifier control cable. The spindle motor control circuitry also monitors itself for faults and reports them to the power control PCB, which reports them to the logic unit on the control logic PCB. If a fault occurs, the power control PCB will sequence power off. Fault information is displayed in the form of three LEDs on the PCB:

- SP CONT FLT - which reports faults in control of the spindle motor.
- SP SPD FLT- which reports faults in the rotational speed of the spindle motor.
- SP ENABLE STATUS - which reports spindle enable status.

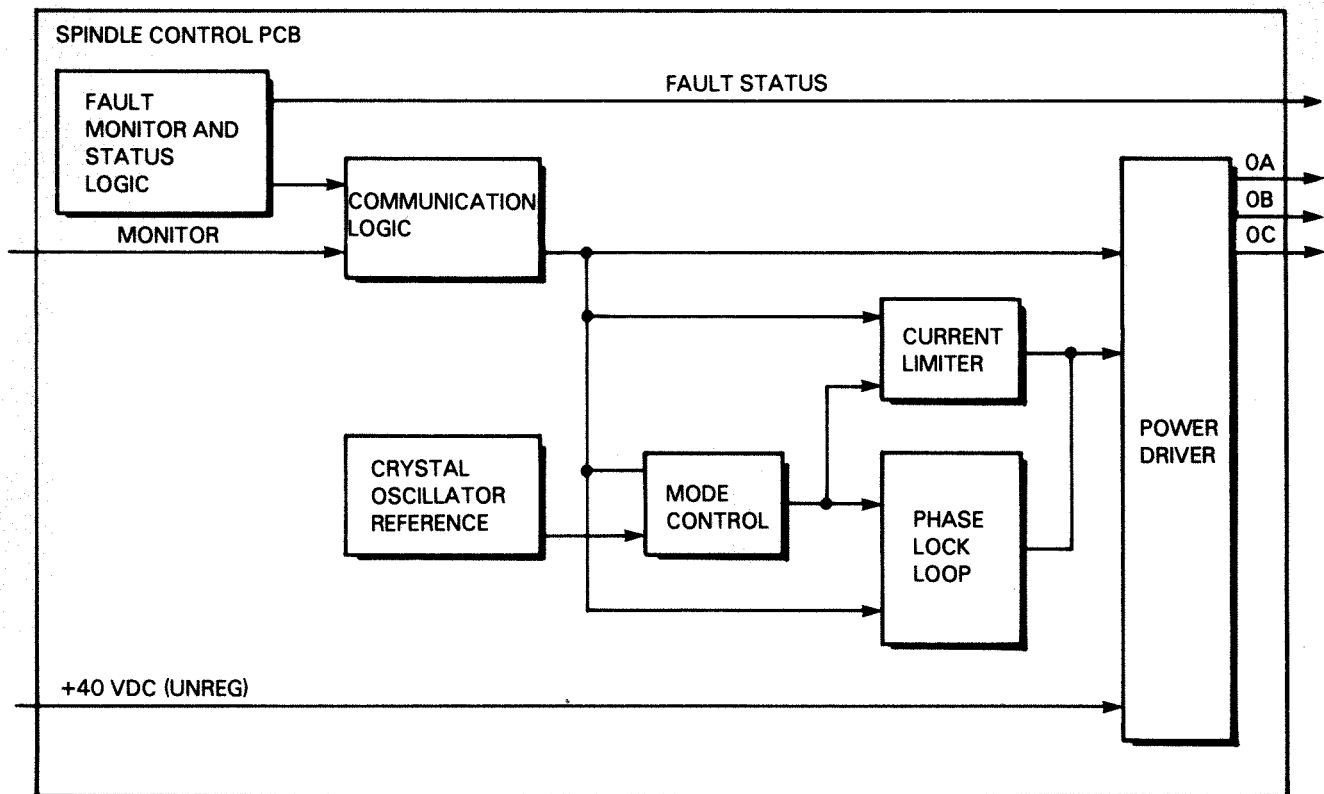

FS-07131

Figure 3-20. Spindle Control PCB Block Diagram

### 3.3 OPERATIONAL THEORY

The 6236 disk drive is used to store and retrieve data from the recording disk so the primary functions concerning drive operations are writing to the disk, reading from the disk, and positioning the heads in order to perform those two operations. This section describes the power sequence of the disk drive; the transfer of instructions and data from the host CPU to the controller PCB (PIO commands); the transfer of instructions and data from the host CPU/controller PCB to the disk drive (the control block); and the following four disk operations:

- Write
- Read
- Seek
- Recalibrate

3.3.1 Power-Up Sequence (Including Power-Up Diagnostics) - AC power is applied to the 6236 disk drive by connecting the power cord to an ac source within the rack and turning the circuit breaker (CB) on. Once ac power is applied, the CHK LED illuminates to indicate that ac power has been applied but that dc power has been interrupted.

By activating the front panel power ON/OFF switch (or by turning on the drive CB with the ON/OFF switch in the ON position) the power control PCB will generate a 0.5 second power-on pulse. This pulse will cause the following conditions:

- The ac and spindle relays on the power supply PCB will be energized, which will supply +40V to both the power amplifier and the spindle control PCBs.
- Any prior power faults that caused a power-down will be cleared.
- The microECLIPSE logic unit on the control logic PCB, the spindle control PCB and the power amplifier PCB will be issued a hard reset, which will disable them for the duration of the power-on interval.

As the dc voltages come up, the respective monitor circuits on the power control PCB will indicate the status of that particular voltage. If any hard power faults are present at the completion of the power-up interval the drive will unconditionally power-down. If no power faults are detected at the completion of the power-up interval, the hard resets to the logic unit, the power amplifier and the spindle control PCBs will be removed. At this point the logic unit will begin the power-up diagnostics.

The logic unit executes a series of tests on the disk drive each time the drive powers-up and each time the drive receives a 'run power-up tests' command from the controller PCB. Any hard reset forces the servo into disable and the R/W PCB into write protect.

## 5. TEST SERVO STATIC AND DYNAMIC FUNCTIONS

The seven-segment digital display indicator will be set to the number six. This test exercises a series of static and dynamic checks on the position control PCB and the entire servo system.

## 6. TEST THE SERVO SEEKING FUNCTION

The seven-segment digital display indicator will be set to the number five. This test executes a seek to every track to check the ability to track-follow on every cylinder. If an error occurs, the seek recovery algorithm is run and the test is run a second time. If the test fails the second time, the drive is halted and the fault is displayed.

## 7. TEST HEAD SELECT AND DATA FLOW PORTS

The seven-segment digital display indicator is set to the number four. The data flow control and head select logic is checked. This test involves writing a head select value and data flow value to the read/write control port and checking to see if this was accomplished.

## 8. TEST THE ROTATIONAL POSITIONING SYSTEM

The seven-segment digital display indicator is set to the number three. This test makes a check of the rotational positioning system. This includes the sector counting hardware, the ability of the microECLIPSE to read the sector counter, and the ability of the R/W PCB in conjunction with the servo surface to produce sector and index pulses. This is accomplished by seeking to different cylinders and testing the time between sector pulses.

## 9. DATA HOOK TEST

The seven-segment digital display indicator is set to the number two. This test checks the RLL encoder/decoder circuitry and the R/W processor on the control logic PCB. This is accomplished by seeking to track 786 and writing data into the FIFO, testing that data.

## 10. READ/WRITE/READ TEST

The seven-segment digital display indicator is set to the number one. This test checks the ability of the disk to read and write properly. This is accomplished by seeking to cylinder 786 and performing a read/write/read on each of the sixteen heads.

At the completion of the power-up sequence and the power-up diagnostics the RDY LED will illuminate and the seven segment digital display indicators will go blank, indicating that the drive is ready for normal operations.

3.3.2 PIO Commands to/from 6236 Controller PCB - The controller PCB receives commands from the host CPU via the PIO bus, which are used to manipulate the controller. The standard Data General I/O instructions set (DIA, DIB, DIC, DOA, DOB and DOC) are used to transfer information between the host CPU and the controller PCB.

PIO commands are used for the following operations:

- Transfer of user options between host CPU and controller PCB.  
User options are:
  - a. Mapping options
  - b. Interface options
  - c. Controller PCB options
  - d. Disk drive options
- Retrieve status information on the disk drive (can be used to retrieve status of up to four disk drives per controller).
- Start, stop and control a Control Block (CB) list.
- Enter/exit controller PCB diagnostic mode.
- Send a hard reset to the controller PCB.

3.3.3 The Control Block - Control Block commands consist of a set of commands that use two special data structures for transmitting commands, data, and status information:

- COMMAND BLOCKS (CB), which specify drive operations and data transfers; and,
- INFORMATION BLOCKS, (IB) which specify drive and controller options and status information when an error occurs.

A control block is a user-defined block stored in the host memory. This block gives the controller all the information it needs to perform a drive operation (i.e., read, write, how much data to transfer). A number of control blocks can be linked together to establish a control block list, which will supply the controller PCB continuous flow of disk drive instructions. Once the controller knows the address of the first control block in a control block list (via a PIO command), it will continually fetch and perform the instructions in the control blocks without interrupting the host CPU.

If the PIO instruction from the host CPU to the controller PCB specifies a control block address, the controller fetches the control block from the host memory over the BMC bus. The controller PCB then performs the drive operation specified in the control block.

There are two types of information blocks (IB):

- User option
- Extended Status



There are three types of user option information blocks (IB) that can be specified:

- Controller options - specify the number of controller retries for soft errors.
- Interface options - specify universal information the host CPU needs to know about the disk drive.
- Unit options - specify universal and device-specific information about the disk drive.

The extended status IB supplies the host CPU with error status information. This IB will give the ending memory address (where the error occurred) and also supply a report on both the controller PCB and the disk drive. The information supplied can be used to resolve the error that has occurred.

3.3.4 Seek Operation - When the 6236 controller PCB determines (by an instruction in a control block) that the servo heads are to be moved, a command and new address is sent to the control logic PCB in the disk drive via the command/data bus. The command informs the microECLIPSE that a seek is to be performed and the address determines where the servo heads will be positioned after the seek has been performed.

The microECLIPSE stores in its memory, on the control logic PCB, the absolute track address of the heads. It uses this absolute address and the new address to calculate the Distance-To-Go (DTG) to the new position and the direction that R/W heads have to move. The DTG is loaded into a register, which will be used to control the stepping of the servo. The direction is loaded into a register to control the movement of the linear motor.

The microECLIPSE sends the direction information to the position control PCB via the position control bus. The position control PCB switches from a track following mode to a course seek mode. This data is passed to the power amplifier PCB, which uses this data to produce the current to move the linear motor (in the HDA) either towards the spindle or away from the spindle (according to the determined direction).

As the linear motor moves the heads in the HDA, the position control decreases the DTG register by 1. The microECLIPSE monitors this signal.

When the DTG register = 1, the microECLIPSE sends a signal to the position control PCB to change from course seek mode to fine seek mode. In fine seek mode, reference information to servo head position is continually checked (in course seek mode, reference information is checked only at every 1/4 servo track).

At the next track crossing, the microECLIPSE verifies that the servo head position is the same as the address specified in the control block. The R/W heads are now on track and send a signal to the position control PCB to switch from fine seek mode to track following mode. The position control PCB sends the signals to the power amplifier PCB, which controls the linear motor (in the HDA), to maintain position on data cylinder center. The seek is complete.

3.3.5 Write Operation - The controller PCB initiates a write operation from instructions in a control block. This CB will supply the instruction to write; an address to tell where to write the data on the recording disk; a host CPU memory starting address of where the data is stored; and a count of how much data to transfer.

The controller PCB transmits a packet to the FIFOs on the control logic PCB. The packet is called a NEW Block Command and contains the type of operation to be performed; the cylinder address; and the starting head and sector addresses. The microECLIPSE fetches this information from the FIFOs; checks that all packet parameters are in range; and initiates a seek operation.

Once the seek is successfully completed, the microECLIPSE selects the starting head and waits for the target sector less an offset to appear on the sector counter. The offset is pre-programmed by the controller PCB. When this sector count is seen the microECLIPSE interrupts the controller. If the controller responds to the interrupt by putting the command/data bus between the controller and the drive into the data mode; the microECLIPSE writes a control word to the R/W processor. The control word causes the R/W processor to start writing on the next sector.

During the transfer, the controller PCB reads each sector's header. If the header read is the header expected then the controller PCB transmits the parallel write data to the control logic PCB. If the header read is not the header expected, the controller PCB skips that sector and waits for the header of the next sector.

The R/W processor controls the actual encoding of the input from the controller PCB to digital serial write data, the 6236 disk drive uses a run length limited recording code called 2-8. This encoding is how the sector will be recording on the recording disk. This includes preamble, header, data, CRC and ECC (refer to Figure 3-21).

The R/W Processor requests data from the controller PCB. The controller PCB sends 523 bytes of data on the control/data bus to the control logic PCB. The FIFO/data flow logic directs the data to the R/W processor. The R/W processor 2-8 encodes the input to serial write data. This serial write data is sent from the drive logic PCB to the R/W PCB via the R/W/servo signals bus.

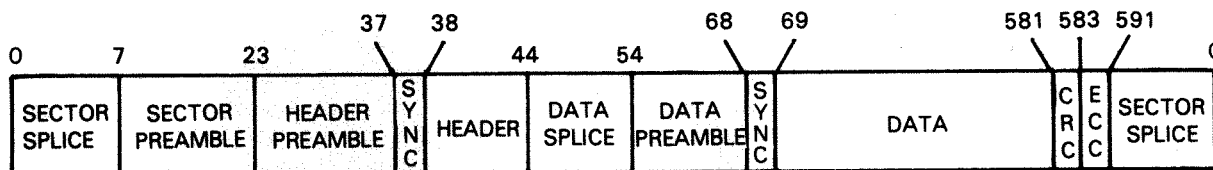

FS-07132

Figure 3-21. Data Sector Format

The function of the R/W PCB during a write operation is to take the serial write data from the control logic PCB and convert it to write current that will drive the heads in the HDA. The R/W PCB converts the serial write data to write current and sends these signals to the heads in the HDA via the R/W/servo data bus.

This write current produces a flux transition in the selected head and the data, which has been recorded on the media.

The write operation continues until the controller PCB's 2901 determines that the requested number of sectors have been transferred. At this point the 2901 puts the command/data bus into the command mode. The drive's microECLIPSE sees the bus switch to command mode and turns off the R/W processor. Once the R/W processor is turned off, the microECLIPSE returns the data flow control logic to the idle state. In the idle state the FIFOs on the control logic PCB are available to the controller PCB for the initiation of the next NEW Block Command.

**3.3.6 Read Operation** - The controller PCB initiates a read operation from instructions in a control block. This control block will supply the instruction to read; an address to tell where to read the data on the recording disk; a host CPU memory starting address of where the data is to be stored; and a count of how much data to transfer.

The controller PCB transmits a packet to the FIFOs on the control logic PCB. This packet is called a NEW Block Command and contains the type of operation to be performed; the cylinder address; and the starting head and sector addresses. The microECLIPSE fetches this information from the FIFO, checks that all packet parameters are in range and initiates a seek operation.

Once the seek is successfully completed, the microECLIPSE selects the starting head and waits for the target sector less an offset to appear on the sector counter. The offset is pre-programmed by the controller PCB. When the sector count is seen, the microECLIPSE interrupts the controller PCB. If the controller responds to the interrupt by putting the command/data bus between the controller PCB and the drive into data mode, the microECLIPSE writes a control word to the R/W processor. The control word causes the R/W processor to start reading on the next sector.

During the transfer the controller PCB reads each sector's header. If the header read is the header expected then the controller PCB receives the parallel read data from the control logic PCB. If the header read is not the header expected, the controller PCB skips that sector and waits for the header of the next sector.

The read operation continues until the controller PCB's 2901 determines that the requested number of sectors have been transferred. At this point the 2901 puts the command/data bus into the command mode. The drive's microECLIPSE sees the bus switch to command mode and turns off the R/W processor. Once the R/W processor is turned off the microECLIPSE returns the data flow control logic to the idle state. In the idle state the FIFOs on the control logic PCB are available to the controller PCB for the initiation of the next NEW Block Command.

**3.3.7 Recalibrate Operation** - The servo surface radial format for the 6236 disk drive (refer to Figure 3-22) consists of outer guard bands, a data zone, recalibration tracks, inner guard bands and a landing zone. The inner guard bands and the recalibration tracks are important in a recalibration procedure.

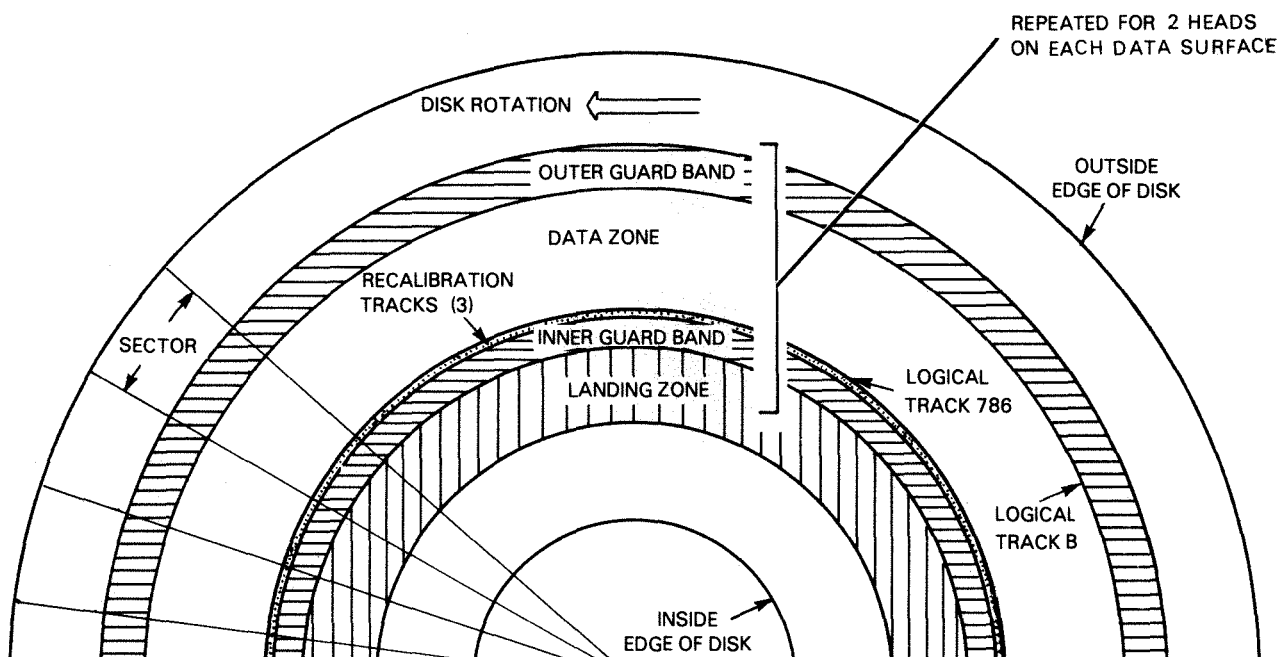

FS-07133

Figure 3-22. SERVO Surface Radial Format

A recalibration operation is performed to position the heads at a known absolute address. A recalibration procedure can be started by either a control block or the controller PCB, if the controller PCB has lost the absolute address for some reason.

The controller PCB informs the control logic PCB that a recalibration operation is to be performed via the command/data bus. The logic unit immediately informs the position control PCB to move the heads towards the spindle, while sensing the servo input from the R/W PCB. The power amplifier PCB produces the current needed to drive the linear motor in the HDA, moving the heads across the recording media.

The heads are moved until the logic unit senses the inner guard band region. At this point, the logic unit issues a command to the position control PCB to reverse direction and move outward at low velocity. At this time the microECLIPSE is sensing the servo input for the recalibration track code. Once the recalibration track code is sensed by the logic unit, it sends a track following command to the position control PCB locking the heads on the recalibration track. The recalibration operation is then complete.

With the heads positioned upon the recalibration track, the controller PCB has re-established an absolute address. It now knows where the heads are and can continue with other operations.

## SECTION 4

### FAULT DIAGNOSIS

This section describes how to isolate faults in the 6236/6237 disk drive subsystem. The following subsections are included:

- 1) Troubleshooting Reference Information - This subsection provides disk drive functional troubleshooting information.
- 2) Initial Checkout - This procedure can help to pinpoint problems and save time by verifying connections and basic problems first.
- 3) Troubleshooting Flowcharts - The troubleshooting flowcharts are used to isolate most problems and error conditions in the disk drive subsystem. The flowcharts should locate error conditions, isolate them to a replaceable FRU, and reference the appropriate removal/replacement procedure in Section 5.
- 4) Diagnostic Troubleshooting Programs - This subsection describes the diagnostic and reliability programs and how to use them in isolating error conditions in the disk drive. Observe all NOTES and CAUTIONS when using the diagnostic and reliability programs.

#### 4.1 TROUBLESHOOTING REFERENCE INFORMATION

The following information is provided to aid in disk drive troubleshooting.

- Reference information in Sections 2 and 5 of this document:

Refer to Section 2 of this document for information on the operating controls and procedures for the disk drive. It provides information on the internal and external control switches and indicator lights. It also describes disk drive operating and monitoring procedures, operator maintenance, and the procedure to follow in an emergency condition.

The troubleshooting flowcharts, front panel digital display indicator (error code listing), and diagnostic programs indicate possible failing Field Replaceable Units (FRUS). Refer to Section 5 of this document for procedural information on the removal and replacement of the FRUs in the disk drive subsystem.

- Reference Illustrations:

Refer to the following figures and tables when troubleshooting 6236/6237 subsystem problems:

- Figure 4-1. FRU and Connector Locations

Use this figure as a guide in locating FRUs that are referenced in the front panel digital display indicator (error code listing), diagnostic programs and in the troubleshooting flowcharts. This figure provides an illustration of FRU connector locations, use it as a guide when connectors are referenced in the troubleshooting flowcharts.

- Figure 4-2. 6236/6237 Interconnection Diagram

Use this figure as a guide to the cables that interconnect the disk drive FRU PCBs, power supply assembly, and head disk assembly (HDA).

- Figure 4-3. 6236/6237 Interconnection Signals

Use this figure as a guide to the signals that are transmitted through the connectors (pins) that are illustrated in the interconnection diagram (Figure 4-3).

- Figure 4-4. LED, Fuse and Switch Locations

Use this figure as a guide to the location of LEDs, fuses and switches in the 6236/6237 disk drive.

- Table 4-1. Spindle Control PCB LEDs
- Table 4-2. Power Amplifier PCB LEDs
- Table 4-3. Power Control PCB LEDs
- Table 4-4. Internal Switches
- Table 4-5. Fuses

Use these tables for information on: the normal/error state and corresponding drive status for the LEDs; fuse ratings and voltage information; and the functional description of position #1 and #2 on the Write Protect switch on the read/write PCB and the Disable switch on the power amplifier PCB.

Data General Corporation (DGC) has prepared this manual for use by DGC personnel and customers as a guide to the proper installation, operation, and maintenance of DGC equipment and software. The drawings and specifications contained herein are the property of DGC and shall neither be reproduced in whole or in part without DGC's prior written approval nor be implied to grant any license to make, use, or sell equipment manufactured in accordance herewith.

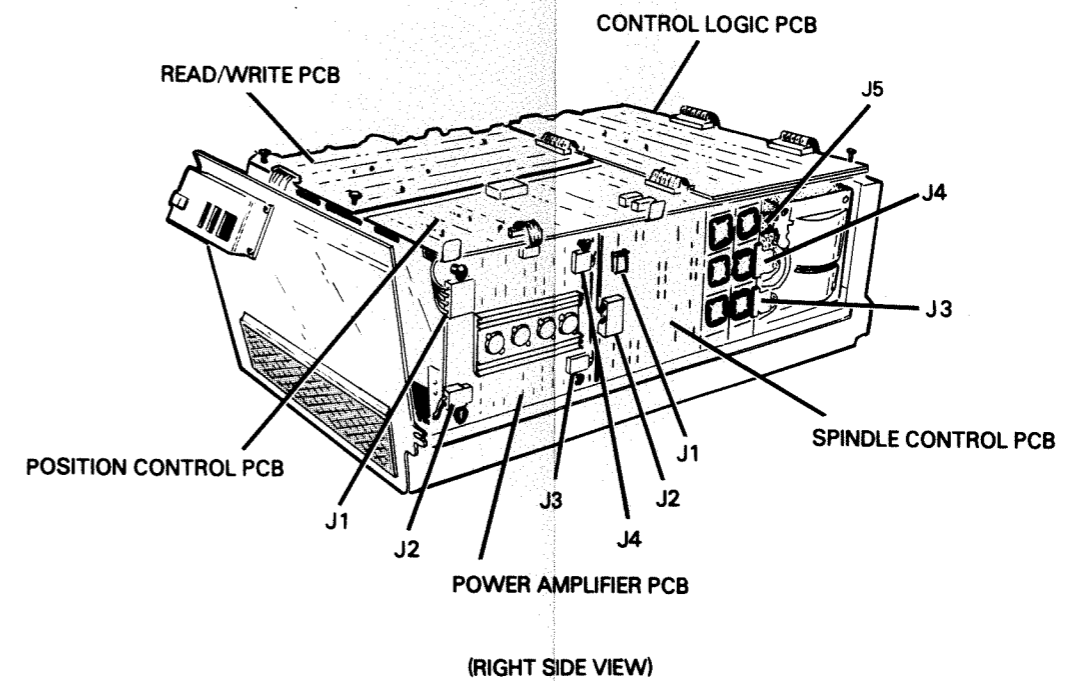
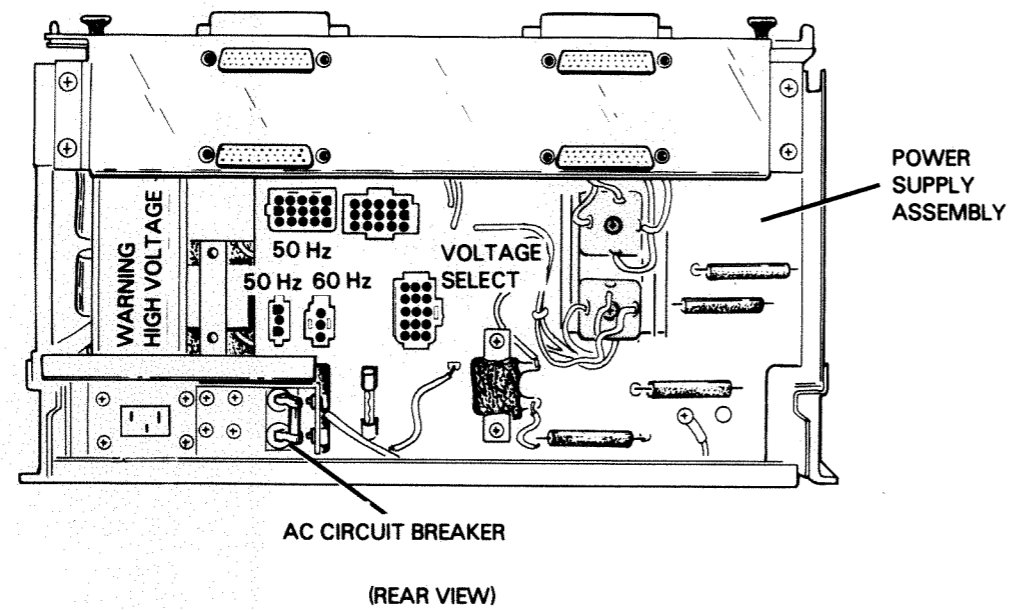
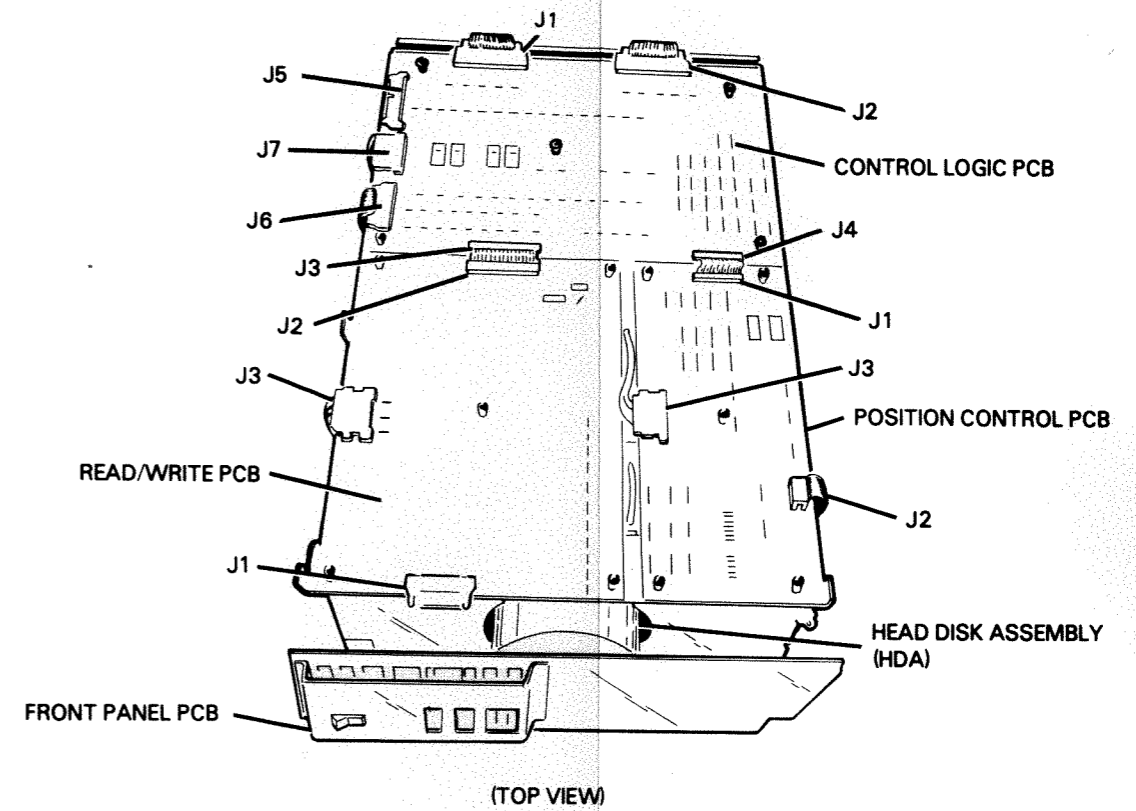
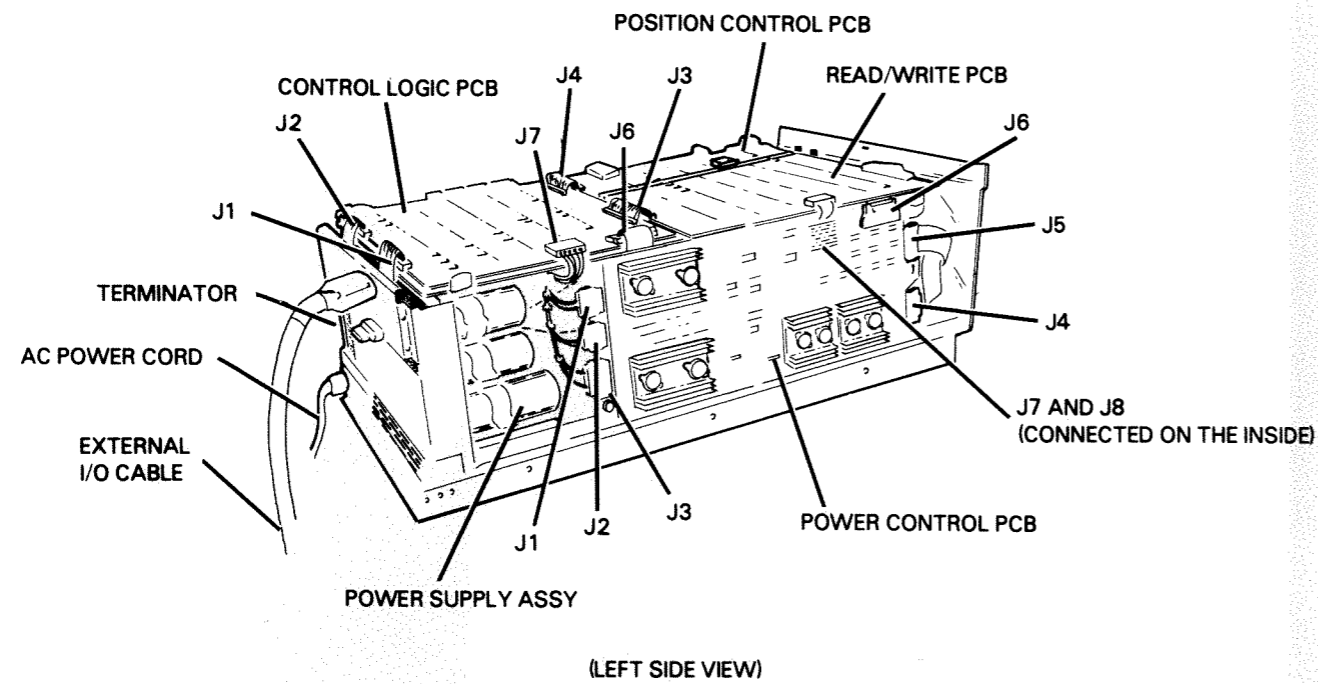

FS-07135

Figure 4-1. FRU and Connector Locations

015-000137  
4-3/4-4



Data General Corporation (DGC) has prepared this manual for use by DGC personnel and customers as a guide to the proper installation, operation, and maintenance of DGC equipment and software. The drawings and specifications contained herein are the property of DGC and shall neither be reproduced in whole or in part without DGC's prior written approval nor be implied to grant any license to make, use, or sell equipment manufactured in accordance herewith.

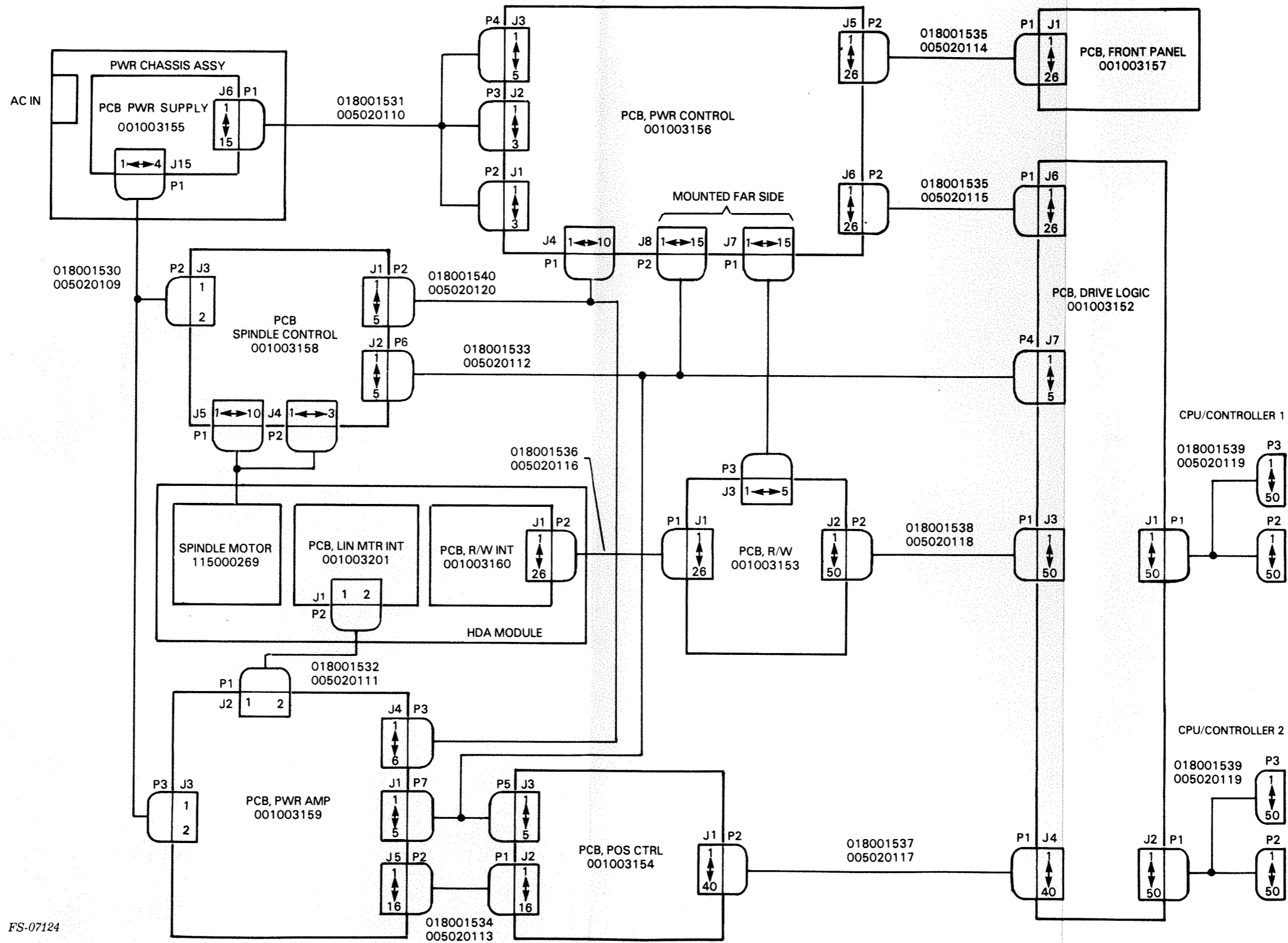

FS-07124

Figure 4-2. 6236/6237 Interconnection Diagram  
015-000137  
4-5/4-6

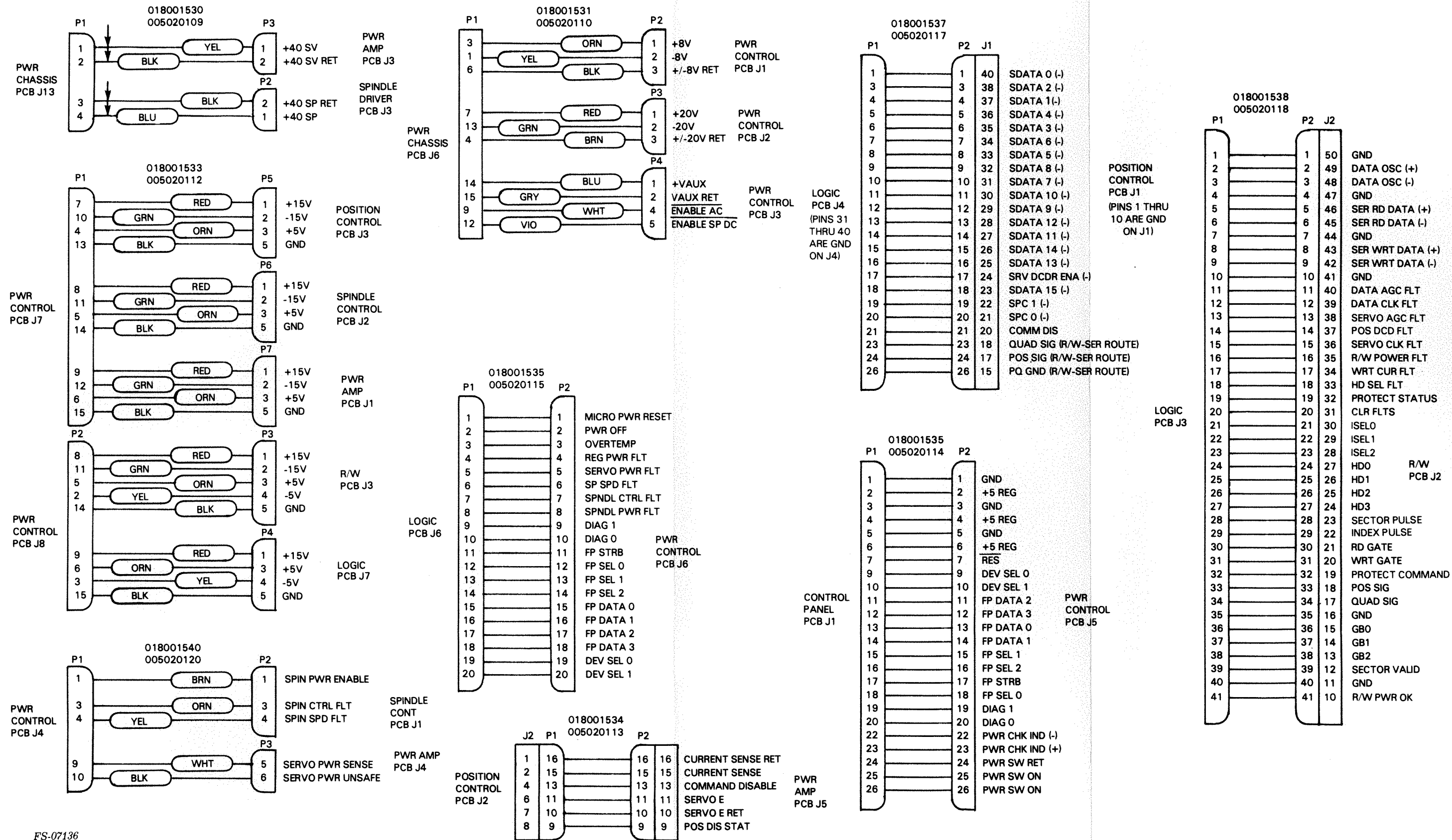
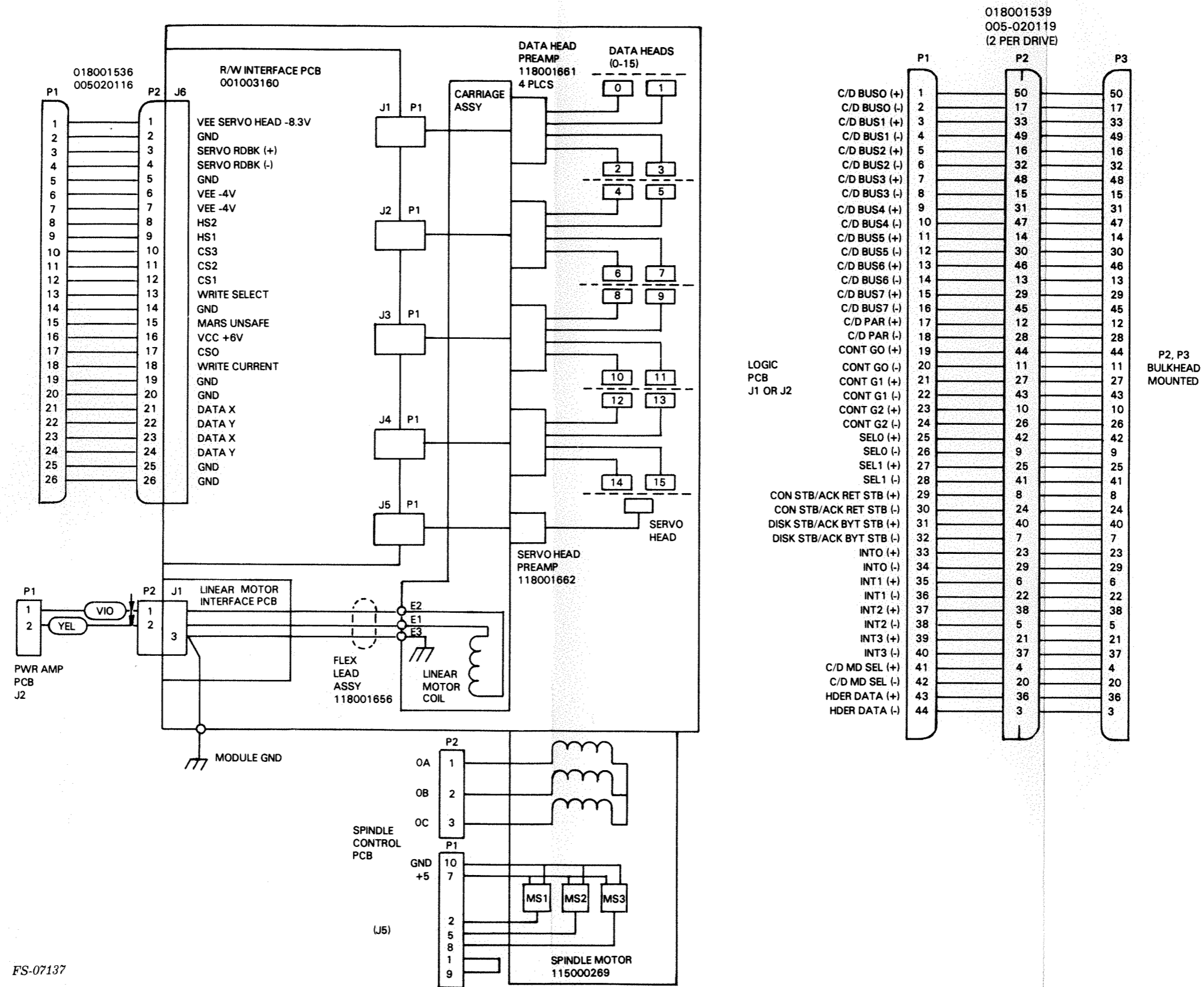

Figure 4-3. 6236/6237 Interconnection Signals (Sheet 1 of 2)

Data General Corporation (DGC) has prepared this manual for use by DGC personnel and customers as a guide to the proper installation, operation, and maintenance of DGC equipment and software. The drawings and specifications contained herein are the property of DGC and shall neither be reproduced in whole or in part without DGC's prior written approval nor be implied to grant any license to make, use, or sell equipment manufactured in accordance herewith.



FS-07137

Figure 4-3. 6236/6237 Interconnection Signals (Sheet 2 of 2)

Data General Corporation (DGC) has prepared this manual for use by DGC personnel and customers as a guide to the proper installation, operation, and maintenance of DGC equipment and software. The drawings and specifications contained herein are the property of DGC and shall neither be reproduced in whole or in part without DGC's prior written approval nor be implied to grant any license to make, use, or sell equipment manufactured in accordance herewith.

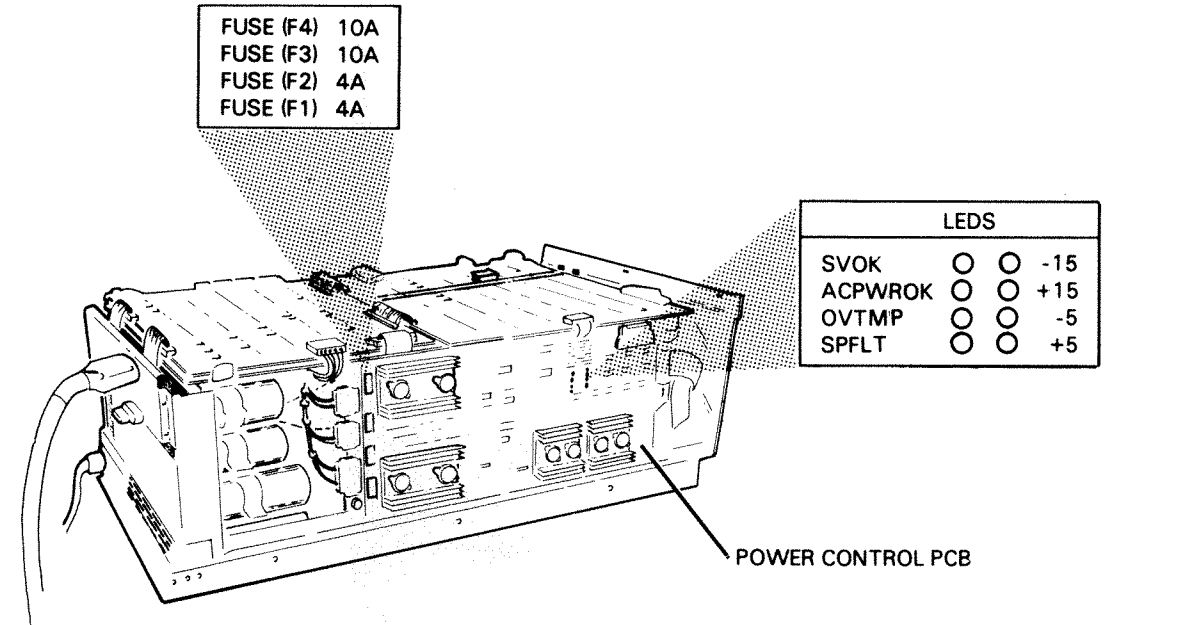

SW1 (WRITE PROTECT SWITCH)	
POSITION#1	WRITE PROTECT
POSITION#2	WRITE ENABLE

READ/WRITE PCB

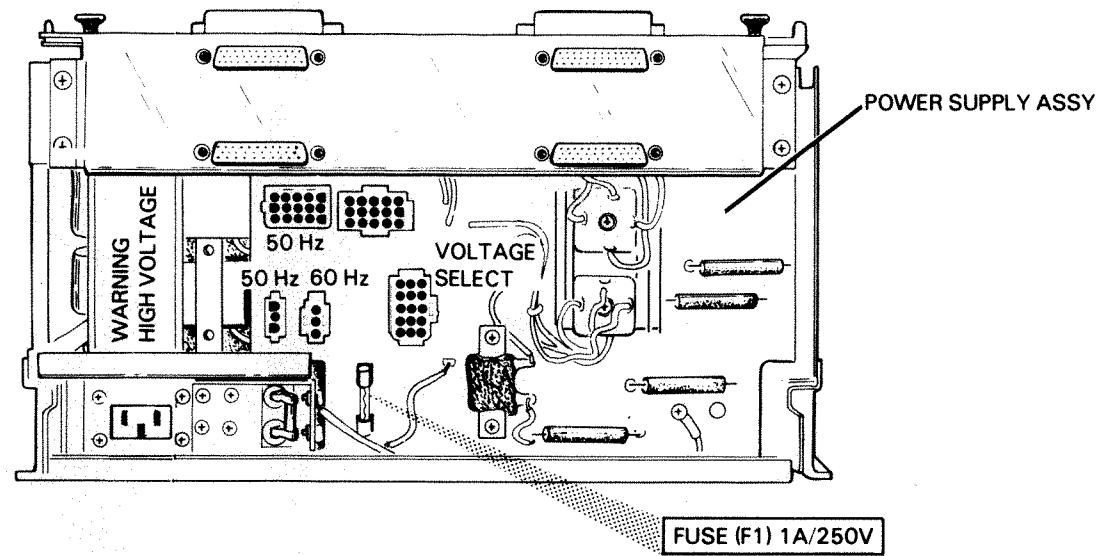
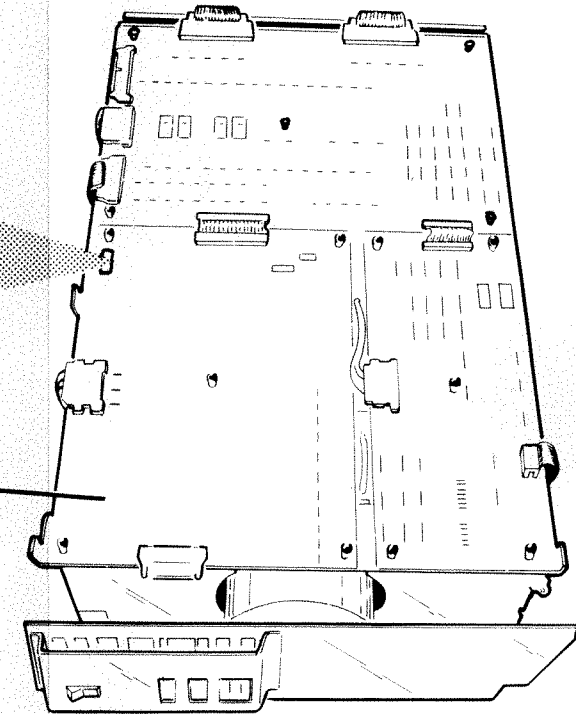

LEDS	
○ 1	(SPINDLE CONTROL FAULT)
○ 2	(SPINDLE SPEED FAULT)
○ 3	(SPINDLE ENABLE STATUS)

LED	
○	SERVO SYSTEM DISABLED

POWER AMPLIFIER PCB

FUSE (F1) 10A SLOW BLO

SW1 (DISABLE SWITCH)	
POSITION #1	SERVO SYSTEM ENABLED
POSITION #2	SERVO SYSTEM DISABLED

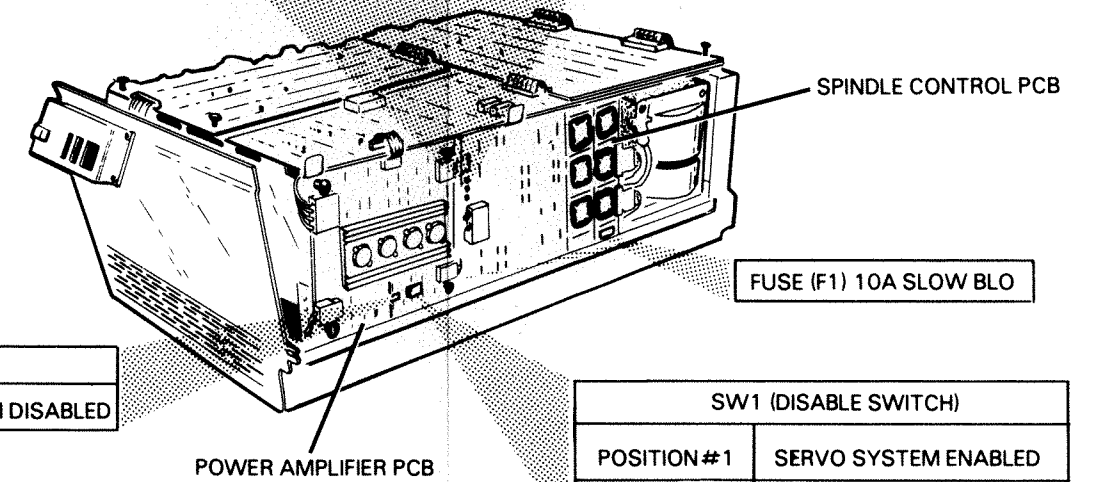

FS-07138

Figure 4-4. LED, Fuse and Switch Locations

015-000137  
 4-11/4-12

Table 4-1. Spindle Control PCB LEDs

LED	NORMAL STATE	DRIVE STATUS	ERROR STATE	DRIVE STATUS
01 (SPINDLE CONTROL FAULT)	OFF	Indicates normal condition in spindle control system.	ON	Indicates fault in the spindle control system. LED momentarily blinks, the drive powers-down.
02 (SPINDLE SPEED FAULT)	OFF	Indicates normal condition in spindle speed/that spindle is up to correct operating speed.	ON	Indicates spindle speed fault. (NOTE: LED will illuminate during 35 sec power-up test (07) and extinguishes when the spindle reaches correct operating speed.)
03 (SPINDLE ENABLE STATUS)	ON	Indicates spindle is in an enabled state.	OFF	Indicates spindle is not in an enabled state.

Table 4-2. Power Amplifier PCB LED

LED	NORMAL STATE	DRIVE STATUS	ERROR STATE	DRIVE STATUS
SERVO SYSTEM DISABLED	OFF	Indicates servo system is in an enabled state.	ON	Indicates servo system is in a disabled state, the LED illuminates when SW1 (Disable switch) is in position #2 (DISABLED). (NOTE: LED illuminates during 35 sec power-up test (07) and extinguishes when spindle reaches correct operating speed.)

**Table 4-3. Power Control PCB LEDs**

LED	NORMAL STATE	DRIVE STATUS	ERROR STATE	DRIVE STATUS
SVOK	ON	When power ON/OFF switch is set in the ON position LED illuminates.	ON	Indicates error condition in the power servo system/blown fuse on the power amplifier PCB causes LED to extinguish.
ACPWROK	ON	When power ON/OFF switch is set in the ON position LED illuminates.	OFF	Indicates loss of ac power, LED momentarily blinks, the drive powers-down.
OVTMP	OFF	Indicates normal temperature in heatsinks.	ON	Indicates over-temperature condition in the heatsinks, causes the drive to power down.
SPFLT	OFF	Indicates normal operating condition in the spindle control system.	ON	Indicates fault condition in the spindle control system causes the drive to power-down.
-15	ON	Indicates the presence of -20VDC.	OFF	Indicates the loss of -20VDC, causes the drive to power-down.
+15	ON	Indicates the presence of +20VDC.	OFF	Indicates the loss of +20VDC, causes the drive to power-down.
-5	ON	Indicates the presence of -8VDC.	OFF	Indicates the loss of -8VDC, causes the drive to power-down.
+5	ON	Indicates the presence of +8VDC.	OFF	Indicates the loss of +8VDC, causes the drive to power-down.

Table 4-4. Internal Switches

SWITCH	LOCATION	POSITION	FUNCTION
WRITE PROTECT	Read/Write PCB	#1	Drive is in the write protect mode, data can not be written to the disk. Causes PROTECT LED on front panel to illuminate.
		#2	Drive is in write enable mode, data can be written to the disk.
DISABLE	Power Amplifier PCB	#1	Servo system is enabled.
		#2	Servo system is disabled. Causes LED (servo system disabled) to illuminate on the power amplifier PCB.

Table 4-5. Fuses

FUSE	RATING	LOCATION	VOLTAGE FUSED
F1	4A	Power Control PCB	+20VDC
F2	4A	Power Control PCB	-20VDC
F3	10A	Power Control PCB	+8VDC
F4	10A	Power Control PCB	-8VDC
F1	10A slo-blow	Power Amplifier PCB	+40VDC
F1	1A/250V	Power Supply PCB	AC

## 4.2 INITIAL TROUBLESHOOTING CHECKOUT

The following paragraphs describe the initial troubleshooting checkout procedure and the procedure for gaining access to the drive.

4.2.1 Initial Checkout - The following is the initial troubleshooting checkout procedure:

1. Verify that the power cord is plugged into the ac power source and the ac circuit breaker(s) is in the ON position.

2. Prior to the replacement of any FRU verify that all inter-cable connections are properly seated. Refer to Figure 4-1 for an illustration of FRU locations and cable connectors, and to Figure 4-2 for an interconnection diagram. Access to the drive must be gained to verify inter-cable connections and to perform disk drive troubleshooting (refer to paragraph 4.2.2).
3. Observe the front panel digital display indicator for an error code prior to beginning flowchart troubleshooting.
  - If an error code is present make note of it, and dump the error log (refer to Section 2). Recycle the drive and power-up the drive. If the drive successfully powers-up without an error code on the front panel digital display indicator, previous error was a soft error.
  - If an error code is not present, examine the error log, recycle and power-up the drive. If the drive powers-up with an error code on the front panel digital display indicator, refer to Figure 4-10 (Front Panel Digital Display Indicator - Error Code Listing). If the drive does not power-up, refer to paragraph 4.3 (Troubleshooting Flowcharts).

#### 4.2.2 Gaining Access to the Drive -

##### CAUTION

Do not operate the disk drive over an extended period of time without the top cover installed. Error rate performance may be degraded without the top cover installed.

The following is the procedure for gaining access to the drive (opening and closing the drive):

##### Opening

1. Depress the two tabs on the sides of the front panel assembly and remove the panel from the chassis.
2. Remove the two mounting screws securing the front cover to the installation cabinet.
3. Slide the drive forward and out of the installation cabinet.

##### CAUTION

When removing the top cover from the base weldment assembly be careful not to damage any wires or ribbon cables.



4. Remove the 18 screws securing the top cover to the base weldment assembly. Carefully bend both sides of the top cover outward (in order to clear all PCBs, wires and cables on the PCB support assembly), lift the cover up and off of the base weldment assembly.

### Closing

#### CAUTION

When installing the top cover on the base weldment assembly be careful not to damage any wires or ribbon cables. Before installing the top cover make sure all wires and ribbon cables are secured and not interfering with the installation of the top cover. The edge of the top cover may damage wires and/or cables when it is installed.

1. Carefully bend both sides of the top cover outward (in order to clear all PCBs, wires and cables on the PCB support assembly), install the top cover onto the base weldment assembly.
2. Secure the top cover by tightening the 18 mounting screws.
3. Carefully slide the drive back into the installation cabinet until the front cover mounting brackets are flush with the installation cabinet rack mounting supports.
4. Secure the drive in the installation cabinet by tightening the two mounting screws.

#### CAUTION

Damage to the disk drive will occur if the disk drive is operated without the coarse air filter installed on the front cover.

5. Make sure the coarse air filter is present and positioned correctly on the front cover. Depress the tabs of the front panel assembly and install it on the front of the disk drive.

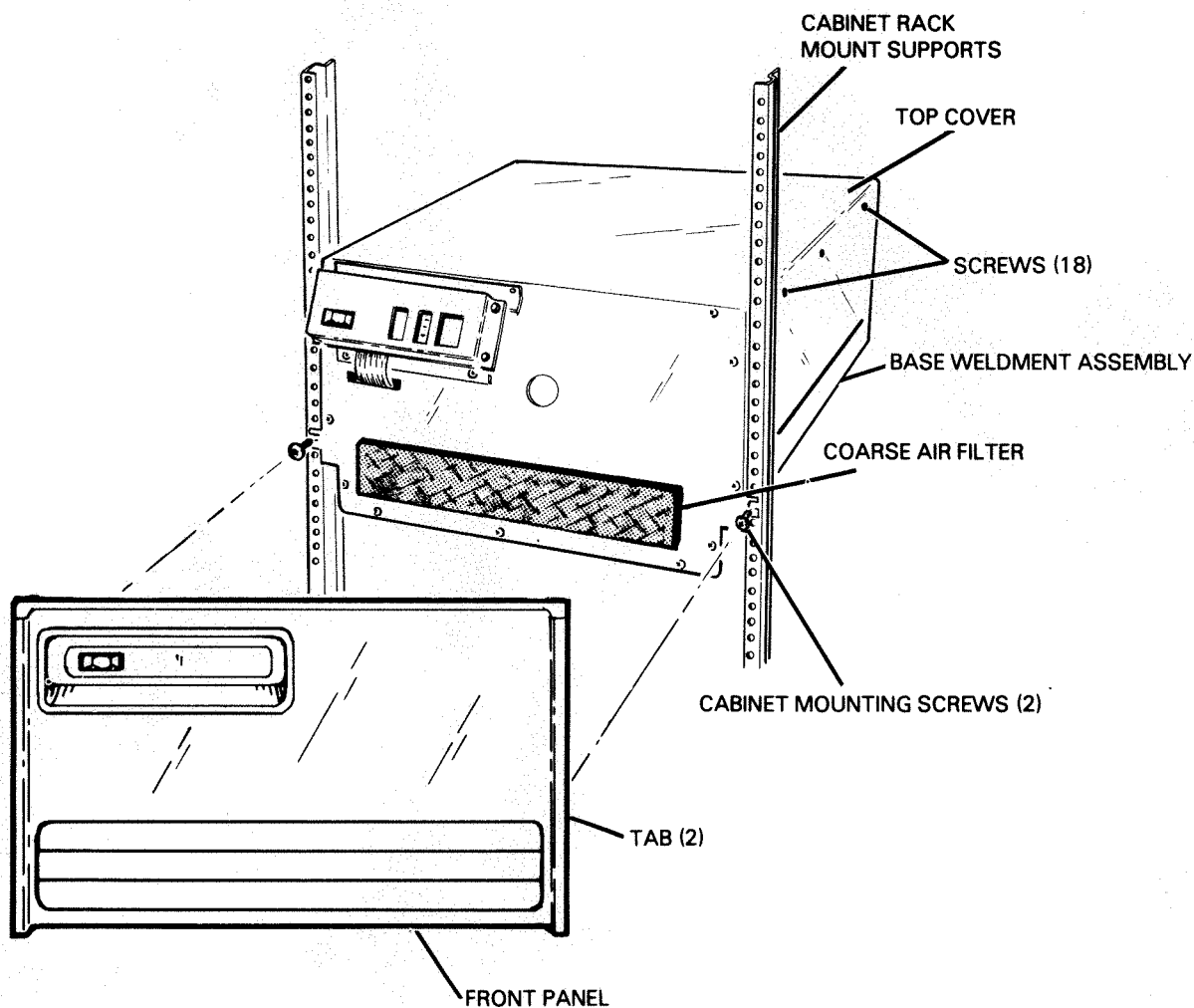

FS-07140

Figure 4-5. Gaining Access to the Drive

### 4.3 TROUBLESHOOTING FLOWCHARTS

The following flowcharts should isolate most error conditions in the FRUs of the disk drive. Refer to Figure 4-2 where plugs and connectors are mentioned in the troubleshooting flowcharts. Always start with the Master Flowchart, Figure 4-6. The following flowcharts and figures are included:

- Figure 4-6. Master Flowchart
- Figure 4-7. AC Power Check
- Figure 4-8. DC Power Check
- Figure 4-9. Power Control PCB Test Points
- Figure 4-10. Front Panel Digital Display Indicator - Error Code Listing

If an error condition points to a FRU, perform the following procedure:

1. Check that all interconnections to the FRU are properly seated (Figure 4-1).
2. If the FRU needs to be replaced, refer to the appropriate procedure in Section 5.
3. After the FRU is replaced, return to the Master Flowchart (Figure 4-6). If the same error exists, reinstall the original FRU and check the cables and wires connecting the FRU.

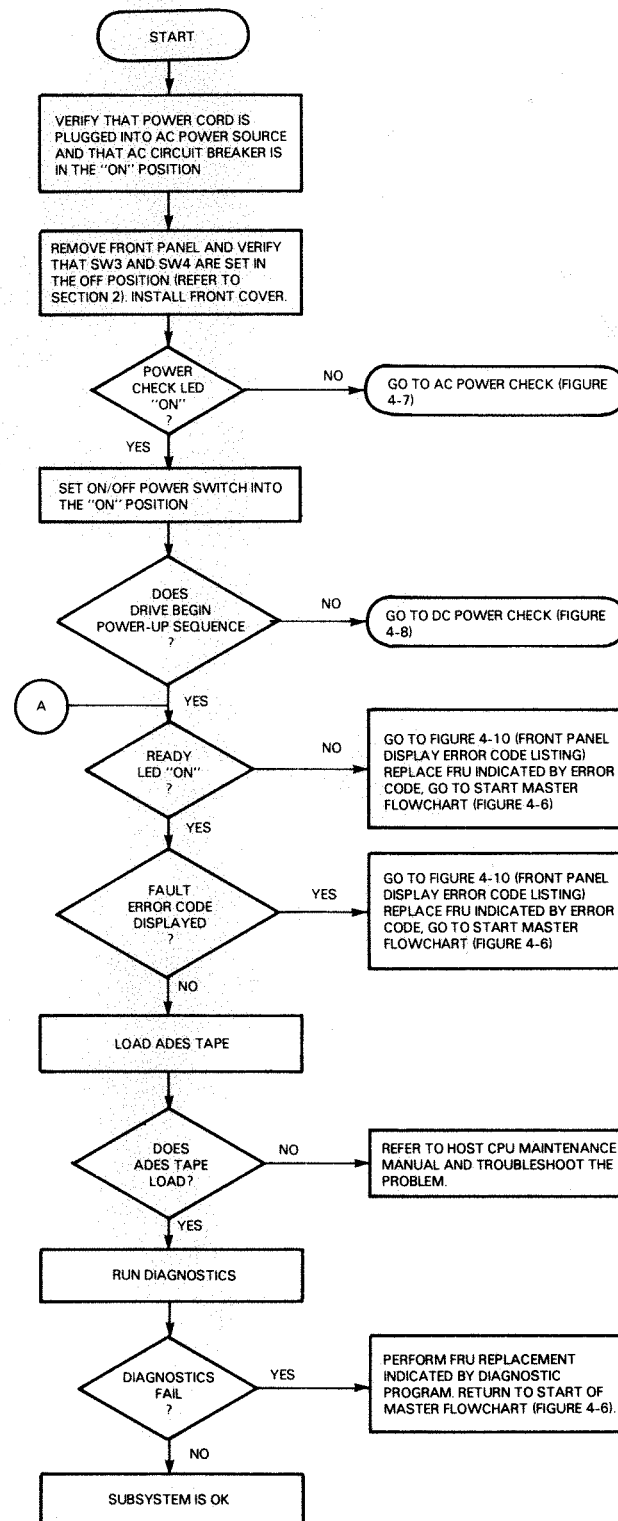

FS-07141

Figure 4-6. Master Flowchart

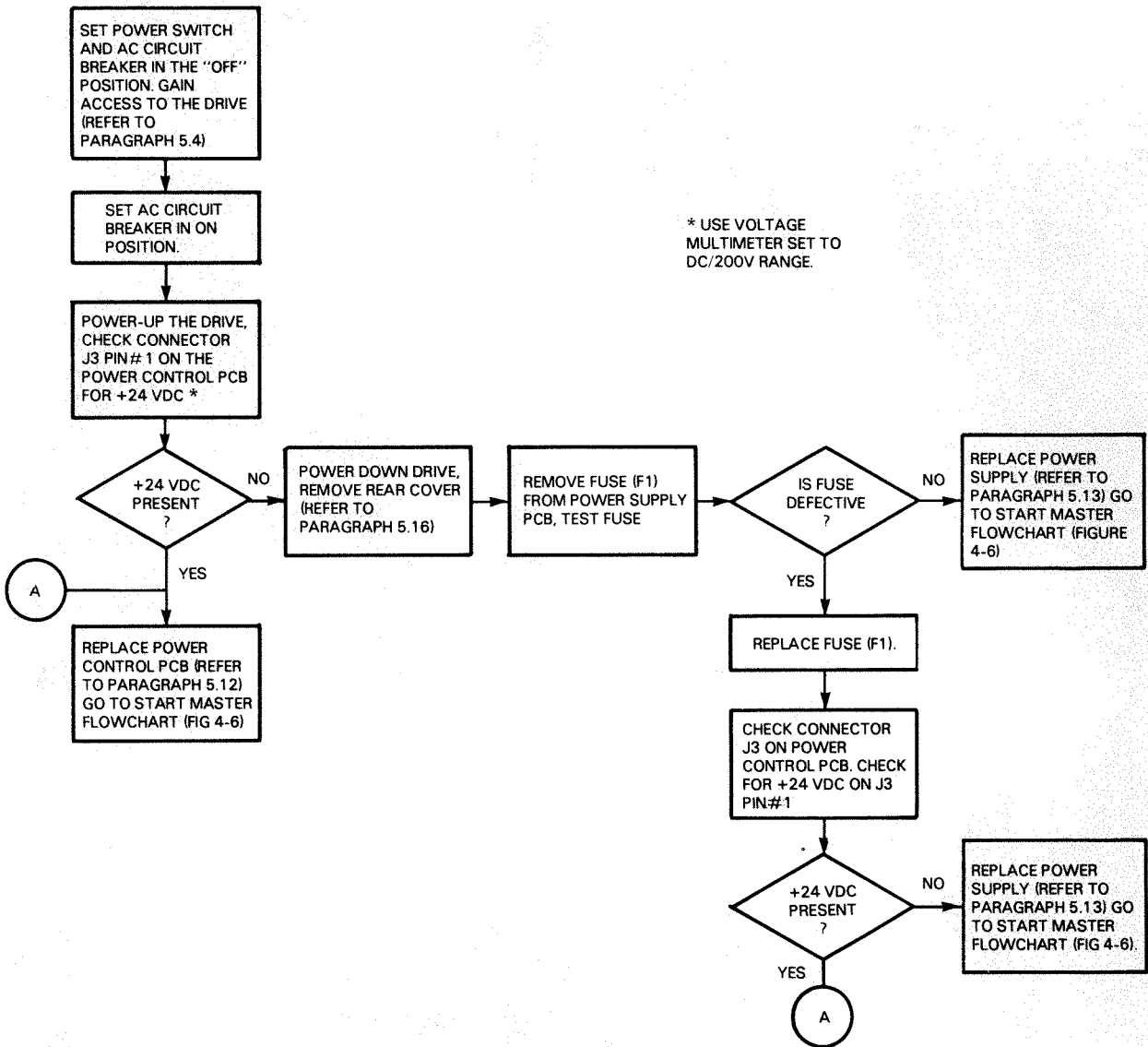

FS-07142

Figure 4-7. AC Power Check

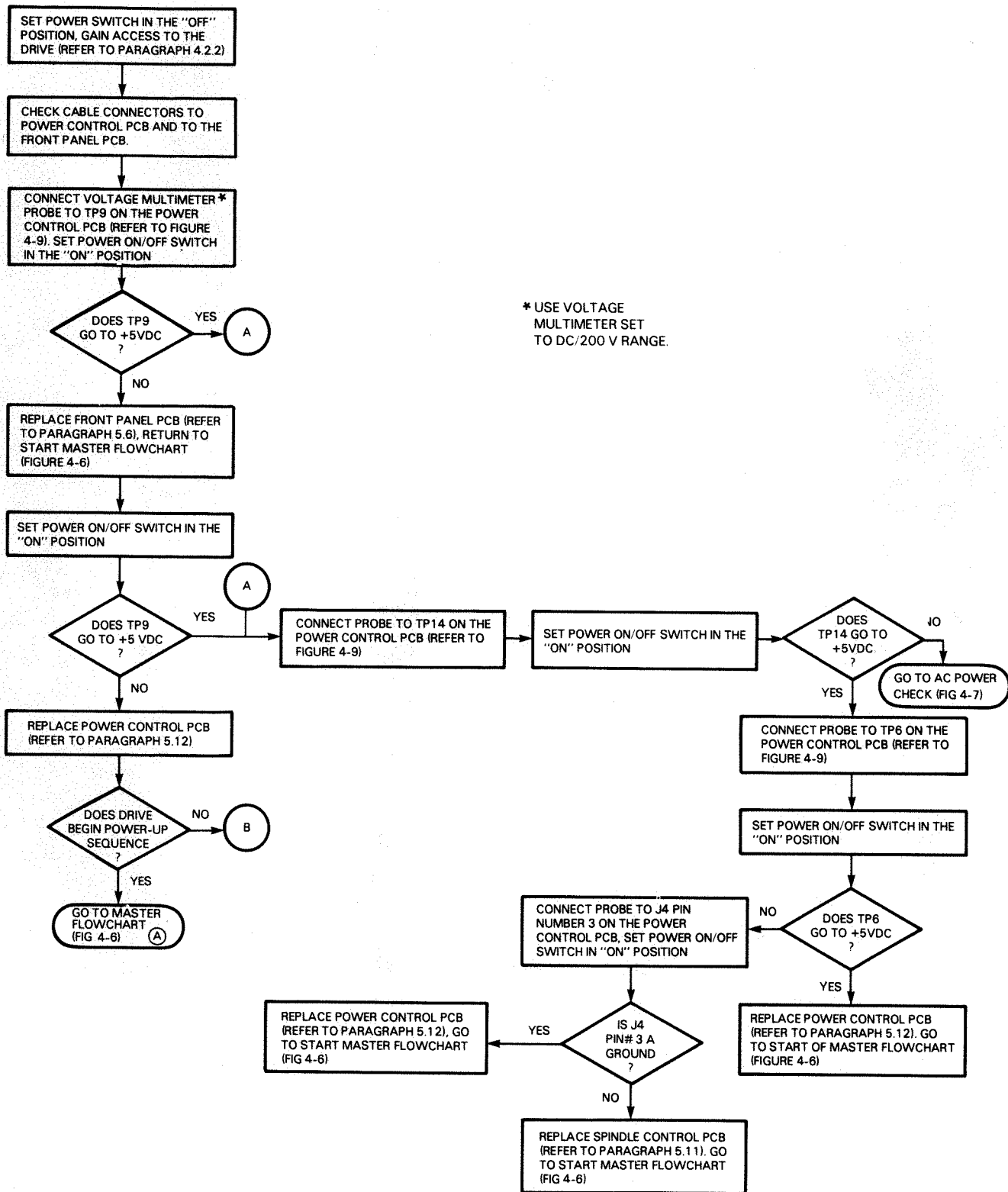

FS-07143

Figure 4-8. DC Power Check (Sheet 1 of 3)

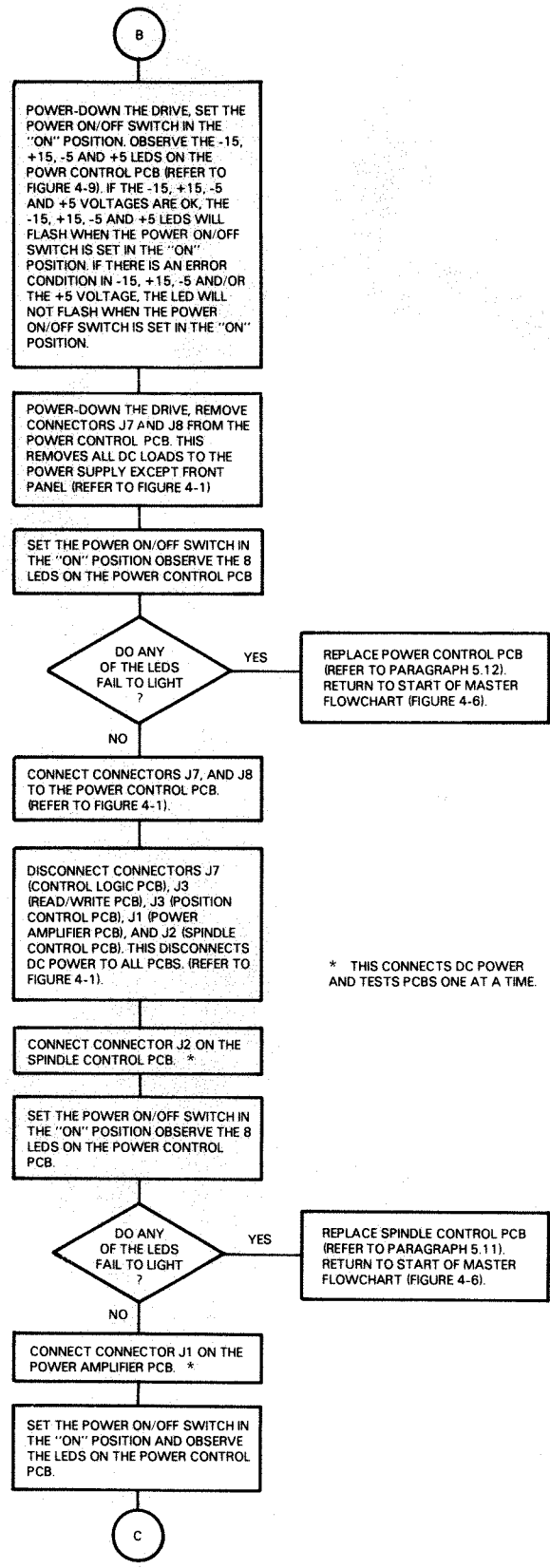

FS-07143

Figure 4-8. DC Power Check (Sheet 2 of 3)

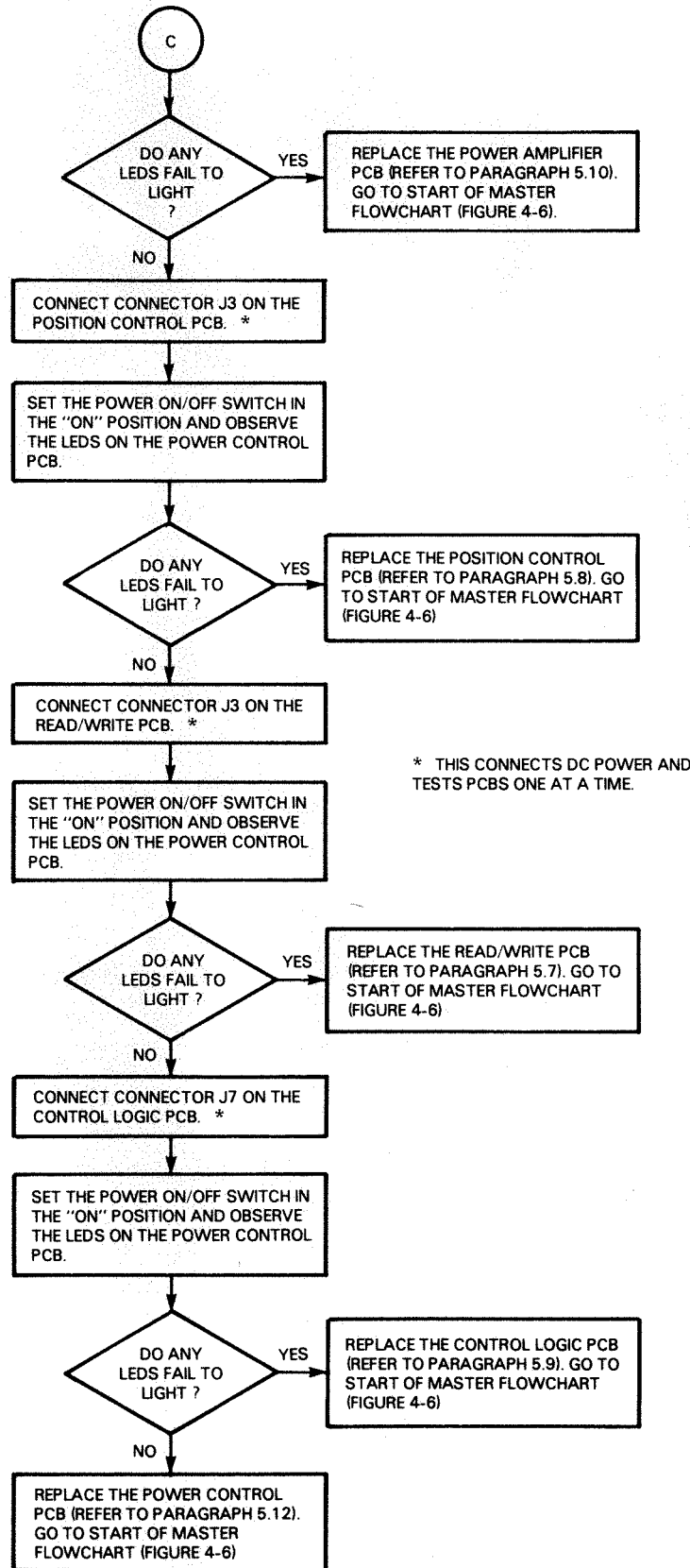

FS-07143

Figure 4-8. DC Power Check (Sheet 3 of 3)



Data General Corporation (DGC) has prepared this manual for use by DGC personnel and customers as a guide to the proper installation, operation, and maintenance of DGC equipment and software. The drawings and specifications contained herein are the property of DGC and shall neither be reproduced in whole or in part without DGC's prior written approval nor be implied to grant any license to make, use, or sell equipment manufactured in accordance herewith.

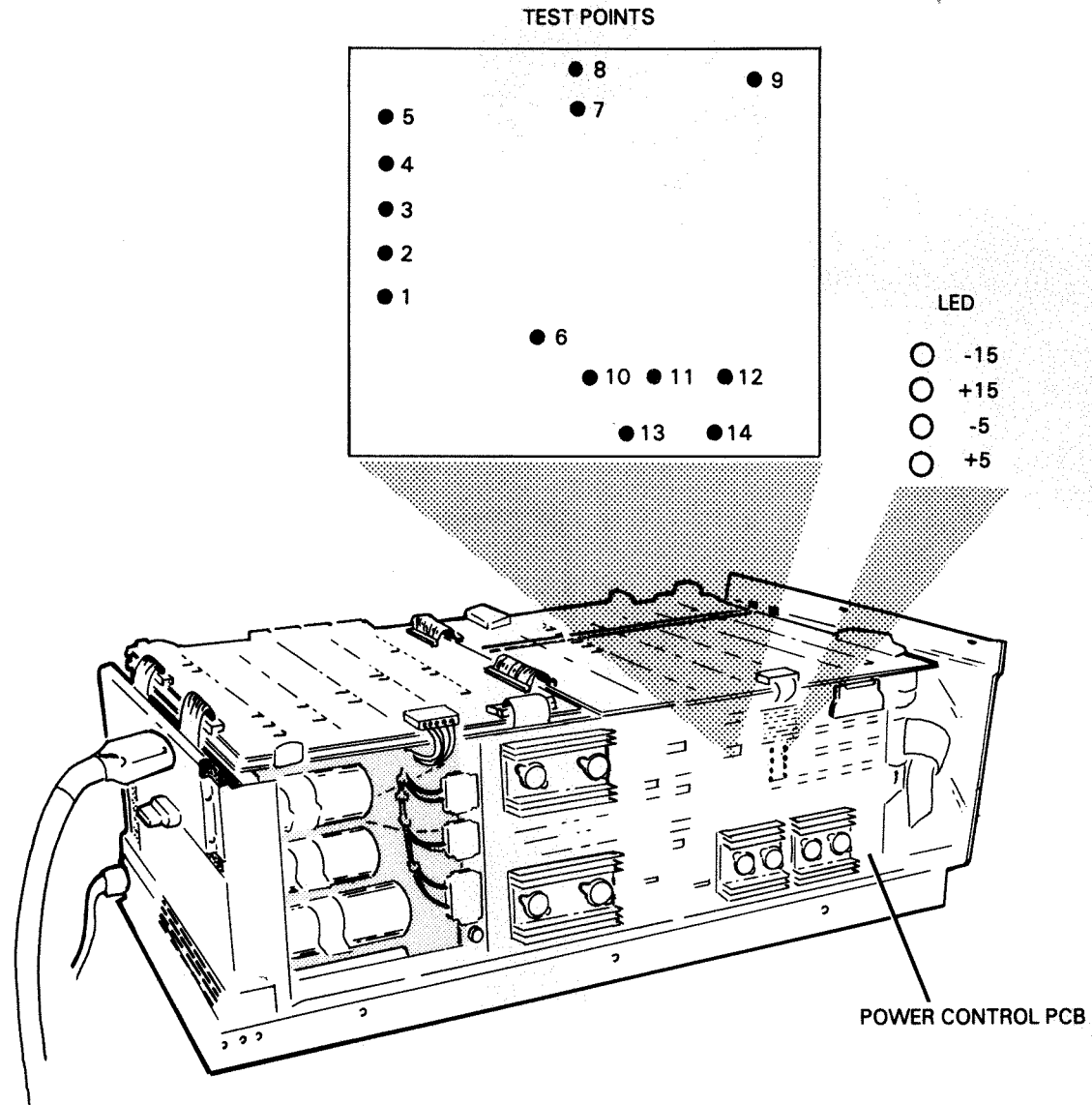

FS-07144

**Figure 4-9.** Power Control PCB Test Points

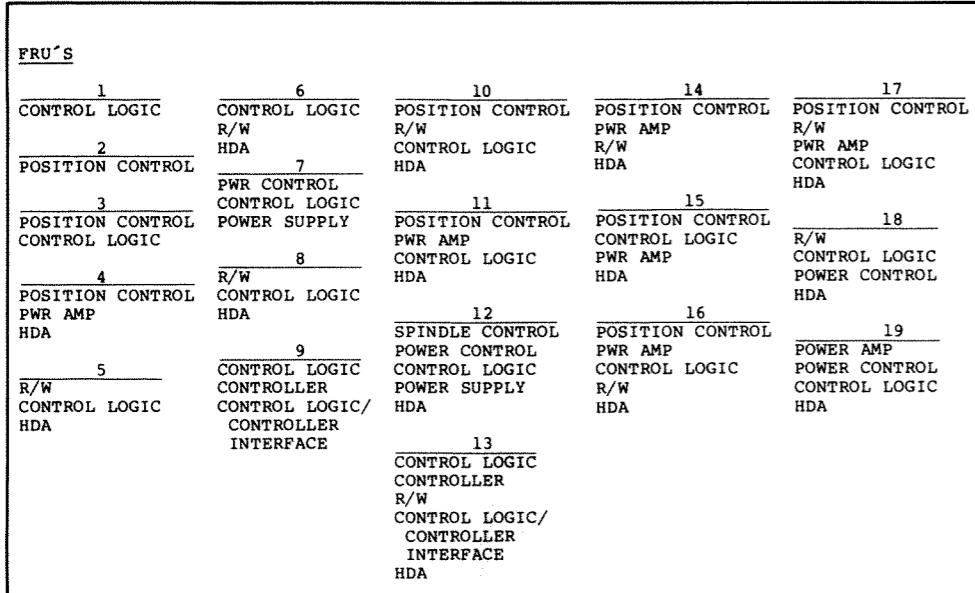

**WARNING**

DO NOT CONFUSE B'S (b) WITH 6'S (6)

**SWITCH SETTINGS**

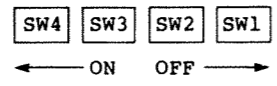

FUNCTION	SW4	SW3	SW2	SW1	UNIT
ON LINE - DISPLAY UNIT + AND ERROR CODE	OFF	OFF	OFF	OFF	0
ON LINE - DISPLAY CURRENT CYLINDER	ON	OFF	OFF	ON	1
OFF LINE - LOOP ON POWER-UP TESTS	OFF	ON	ON	OFF	2
OFF LINE - LOOP ON RANDOM SEEKS	ON	ON	ON	ON	3

IF THE OFF-LINE SWITCH IS SET TO ON WHILE THE DRIVE IS READY, THE DRIVE'S ERROR LOG IS DUMPED ONCE. ERROR CODES ARE DUMPED STARTING WITH THE MOST RECENT.

**6236/6237 ERROR CODES & FRU LISTS REV. 0**

ERR CODE	FRU LIST	DESCRIPTION
20	9	RD/WR OP:CHK PT 0:COMMAND/DATA PULSED COMMAND
21	6	RD/WR OP:CHK PT 0:SYNC ON HEADER ACTIVE TOO SOON
22	13	RD/WR OP:CHK PT 0:HDR/DATA=DATA DURING HEADER
23	6	RD/WR OP:CHK PT 0:SYNC ON DATA ACTIVE TOO SOON
24	6	RD/WR OP:CHK PT 0:HEADER OK ACTIVE TOO SOON
25	13	RD/WR OP:CHK PT 0:RD/WR ERROR REPORTED BY R/W PROCESSOR
26	9	RW/WR OP:CHK PT 1:COMMAND/DATA PULSED COMMAND
27	6	RW/WR OP:CHK PT 1:FORMATTING ERROR:HDR SYNC ACTIVE
29	6	RW/WR OP:CHK PT 1:SYNC ON DATA ACTIVE TOO SOON
2A	6	RW/WR OP:CHK PT 1:FORMATTING ERROR:HDR OK ACTIVE
2B	13	RW/WR OP:CHK PT 1:RD/WR ERROR REPORTED BY R/W PROCESSOR
2C	9	RD/WR OP:CHK PT 2:COMMAND/DATA PULSED COMMAND
2D	13	RD/WR OP:CHK PT 2:FORMATTING ERROR:HDR SYNC ACTIVE
2F	6	RD/WR OP:CHK PT 2:NO SYNC ON DATA
30	6	RD/WR OP:CHK PT 2:NO HEADER OK
31	13	RD/WR OP:CHK PT 2:RD/WR ERROR REPORTED BY R/W PROCESSOR

ERR CODE	FRU LIST	DESCRIPTION
33	6	DATA HOOK:CHK PT 0:SYNC ACTIVE TOO SOON
35	6	DATA HOOK:CHK PT 0:SYNC ON DATA ACTIVE
37	6	DATA HOOK:CHK PT 0:RD/WR ERROR REPORTED BY R/W PROCESSOR
38	6	DATA HOOK:CHK PT 0:FIFO IN NOT READY
39	6	DATA HOOK:CHK PT 0:FIFO OUT NOT READY
3B	6	DATA HOOK:CHK PT 1:SYNC ON HOOK DATA NOT ACTIVE
3D	6	DATA HOOK:CHK PT 1:SYNC ON DATA ACTIVE
3F	6	DATA HOOK:CHK PT 1:RD/WR ERROR REPORTED BY R/W PROCESSOR
40	6	DATA HOOK:CHK PT 1:FIFO IN NOT READY
41	6	DATA HOOK:CHK PT 1:FIFO OUT READY
50	9	ILLEGAL CONTROLLER COMMAND BYTE READ FROM FIFO
51	9	CHECKSUM ERROR ON CONTROLLER COMMAND PARAMETERS
52	9	TIMEOUT:RECEPTION OF CONTROLLER'S COMMAND PARAMETERS
53	9	TIMEOUT: TRANSMISSION OF DRIVE'S STATUS PARAMETERS
56	9	CYLINDER OUT OF RANGE
57	9	SECTOR OUT OF RANGE
58	9	REQUEST TO FORMAT WITHOUT BEING IN DIAGNOSTIC MODE
59	9	ILLEGAL TYPE OF READ/WRITE OPERATION SPECIFIED
5A	9	TIMEOUT CONTROLLER'S START OF R/W OPERATION
5B	9	CONTROLLER INTERRUPT ALREADY ACTIVE
5C	9	RD/WR OP ERROR:DATA MODE ACTIVE AFTER R/W TERMINATED
5D	9	PARITY ERROR
60	8	READ/WRITE POWER FAULT
61	8	RD/WR:SERVO AGC FAULT
62	8	RD/WR:HEAD SELECT FAULT
63	8	RD/WR:SERVO CLOCK FAULT
64	18	RD/WR:WRITE CURRENT FAULT
65	8	RD/WR:POSITION DECODER FAULT
67	8	RD/WR:DATA CLOCK FAULT
68	8	PROTECT STATUS WENT ACTIVE DURING A WRITE/FORMAT
69	8	NO PROTECT STATUS RETURNED BY RD/WR PCB
6A	8	TIMEOUT:SECTOR PULSE
6B	8	"SECTOR VALID":FAILED TO SHOW VALID
6C	8	NEW BLOCK WRITE/FORMAT WHILE DRIVE IN PROTECT
70	16	DYNAMIC TEST: NO DIG P SIGNAL
71	16	DYNAMIC TEST: NO DIG Q SIGNAL
72	16	DYNAMIC TEST: NO LIN P SIGNAL
73	16	DYNAMIC TEST: NO OFF TRK SIGNAL
74	16	SEEK: COARSE SEEK TO FINE SEEK TIMEOUT
75	16	SEEK/DYNAMIC TEST: TRACK PULSE HOLD TIMEOUT
76	16	SEEK/RECAL: FINE SEEK TO ON-TRACK TIMEOUT
77	16	RECAL: TIMEOUT
78	4	SEEK: COARSE SEEK DIRECTION ERROR
79	4	RECAL: DIRECTION ERROR
7A	14	DYNAMIC TEST: CARRIAGE UP TO SPEED TIMEOUT
7B	15	STATIC TEST: NOT IN LZ/IGB
7C	10	DYNAMIC TEST: BAD VELOCITY CALIBRATION
7D	10	SEEK/RECAL: WRONG SERVO SURFACE CODE
7E	11	RECAL/DYNAMIC/STATIC TEST: POSITION DISABLE STATUS ERROR
7F	4	SEEK/RECAL: TRACK FOLLOW SETTLE TIMEOUT
80	5	RECAL: BAD SERVO SURFACE CODE
81	5	SEEK/RECAL/STATIC TEST: SERVO SURFACE CODE NOT READY
82	5	STATIC TEST: SERVO SURFACE CODE IS GARBAGE
83	3	A/D CONVERSION ERROR
84	3	STATIC TEST: TRK PLS HOLD LATCH RESET ERROR
85	3	SEEK/STATIC/DYNAMIC TEST: LDTG=1 LATCH SET/RESET ERROR
86	3	STATIC TEST: VELOCITY REFERENCE DIAGNOSTIC READ ERROR
87	3	STATIC TEST: SERVO ERR DIAGNOSTIC READ ERROR
88	3	STATIC TEST: SEEK PATH DIRECTION ERROR
89	3	DYNAMIC TEST: PHASING ERROR
8A	3	DYNAMIC TEST: DST ERROR
8B	4	SEEK RECAL: FINE SEEK MAXIMUM VELOCITY ERROR
8C	4	SEEK/RECAL: DESTINATION OVERSHOOT

ERR CODE	FRU LIST	DESCRIPTION
8D	4	RECAL: MAXIMUM VELOCITY EXCEEDED
8E	2	SEEK: COARSE SEEK TO FINE SEEK ENTRY PHASE ERROR
8F	2	SEEK/RECAL: TRACK FOLLOW PHASE ERROR
90	2	RECAL: RECAL TRACK PHASE ERROR
91	2	DYNAMIC TEST: VELOCITY REFERENCE ERROR
92	4	SEEK EXERCISER: LAST TEST NOT ON RECAL TRACK
93	17	PWR-UP'S WAIT FOR INR GRD BAND TIMEOUT
94	17	TRACK FOLLOW: OFF TRACK
95	17	TRACK FOLLOW: WR OP NOT STARTED DUE TO OFF TRACK
96	17	RW-PU-TST: UNABLE TO CONFIRM POSITION ON DIAG TRAC
A0	7	POWER OFF
A1	7	OVER-TEMPERATURE
A2	7	REGULATED POWER FAULT
A3	19	SERVO POWER FAULT
A4	12	SPINDLE SPEED FAULT
A5	12	SPINDLE CONTROL FAULT
A6	12	AC POWER FAIL
A7	12	TIMEOUT: SPINDLE UP TO SPEED
B0	1	CHECKSUM ERROR AT "39-W", PART #4263
B1	1	CHECKSUM ERROR AT "46-W", PART #4262
B2	1	CHECKSUM ERROR AT "36-W", PART #4265
B3	1	CHECKSUM ERROR AT "44-W", PART #4264
B4	1	WRONG ROM(S) IN THE CSROMLO SOCKET(S)
B5	1	ALL EPROMS NOT OF THE SAME REV LEVEL
B6	1	MARCH TEST ERROR LO BYTE OF RAM "34-W"
B7	1	MARCH TEST ERROR HI BYTE OF RAM "41-W"
B8	1	ADDRESS TEST ERROR ON RAMS
B9	1	DISABLE OUTS FLOP STUCK ON
BA	1	FIFO SUB-SYSTEM:RESET: FIFO IN NOT READY
BB	1	FIFO SUB-SYSTEM:RESET: FIFO OUT READY
BC	1	FIFO SUB-SYSTEM:WRITE: IN NOT READY
BD	1	FIFO SUB-SYSTEM:WRITE: OUT NOT READY
BE	1	FIFO SUB-SYSTEM:WRITE LAST: IN READY
BF	1	FIFO SUB-SYSTEM:READ: IN NOT READY
C0	1	FIFO SUB-SYSTEM:READ: OUT NOT READY
C1	1	FIFO SUB-SYSTEM:READ LAST: FIFO OUT READY
C2	1	FIFO SUB-SYSTEM:READ/WRITE: BAD COMPARE
C3	1	BUSY SET WITHOUT FIFO OUT RDY BEING SET
C4	1	READ/WRITE CONTROL PORT TEST FAILED
C5	6	RD/WR CONTROL PORT TEST: R/W ERROR FAILED TO SET
C6	6	TIMEOUT CHANGE ON DATA FLOW/DIAGNOSTIC PORTS
C7	1	READ/WRITE ERROR FAILED TO CLEAR
C8	6	HEAD CONTROL PORT TEST FAILED
C9	6	BAD COUNT ON SECTOR COUNTER
CA	6	ROT. POS. TEST: BAD TIMING BETWEEN SECTOR COUNTS
CB	6	DATA HOOK: BYTE READ NOT EQUAL TO BYTE WRITTEN
CC	6	RW-PU-TST: RESET COUNT VALUE INCORRECT
CD	6	RW-PU-TST: WRITE OPERATION FAILED
CE	6	RW-PU-TST: INDETERMINATE, CAN'T RD&WT PROT INHBS WR
CF	6	ROT. POSITION TEST: TIMEOUT SECTOR 55
D0	6	RW-PU-TST: DEAD HEAD
D2	1	MICRO-ECLIPSE STACK FAULT
D3	1	ATTEMPT TO SEEK WITH DATA FLOW IN WRITE MODE
D4	1	NO INTERRUPT STATUS RETURNED FROM INTERFACE
D5	1	INITIATE SEQUENCE NOT YET IMPLEMENTED
D6	1	ILLEGAL VALUE IN CURRENT MODE REGISTER
D7	1	UNEXPLAINABLE SOFTWARE PHENOMON
D8	6	TIMEOUT: PRE-TARGET SECTOR
D9	6	SYNC NOT DETECTED ON HDR DURING A RD/WR OPERATION
DA	6	RD/WR OP: TIMEOUT CHANGE ON SECTOR COUNT BITS
DB	6	RD/WR OP: R/W PROCESSOR SAYS: READ/WRITE ERROR
DC	6	RD/WR OP ERROR: TIMED OUT INDEX
DD	6	TIMEOUT SECTOR VALID DURING A RD/WR OPERATION

Figure 4-10. Front Panel Digital Display Indicator-Error Code Listing

#### 4.4 DIAGNOSTIC TROUBLESHOOTING PROGRAMS

The following subsections describe the diagnostic, functional, reliability, and formatter programs for the 6236/6237 disk drive subsystem. The programs are to be used as a tool in troubleshooting disk drive subsystem problems. Refer to Table 4-6 for a listing of the programs.

##### NOTE

Program run times for the 6236 DIAG, 6236 FUNC, UDKP, and UDKV programs are listed in Table 4-7 (6236 DIAG), Table 4-13 (6236 FUNC), Table 4-17 (UDKP), and Table 4-18 (UDKV).

Table 4-6. 6236/6237 Diagnostic Programs

PROGRAM	DG PROGRAM NUMBER	DG PROGRAM LISTING NUMBER
6236 DIAG	095-002846	096-002846
6236 FUNC	095-002847	096-002847
UDKP RELI	095-002843	096-002843
UDKV RELI	095-002844	096-002844
6236 FMTR	095-002845	096-002845

- 6236 DIAG Program (6236 Moving Head Diagnostic)

The 6236 DIAG is a hardware diagnostic program that exercises the 6236/6237 disk drive subsystem. The 6236 DIAG program tests primarily the controller using on board u code. The drive may be used but only a power up/down test is done to the drive. It provides maximum visibility in indicating failing field replaceable units (FRUs).

- 6236 FUNC Program (6236 Moving Head Disk Hardware/Firmware Function Verification Diagnostic)

The 6236 FUNC verifies the proper operation of the 6236/6237 disk drive subsystem. The 6236 FUNC tests both the disk drive and the controller PCB. The 6236 FUNC has a seek exerciser and it also forces ECC correction errors. The 6236 FUNC will write to either user space or to the diagnostic track only. The 6236 DIAG program should be run before running the 6236 FUNC program. Both FRU and functional information is provided through program error reports.

- UDKP and UDKV RELI Programs (6236/6237 Moving Head Disk Reliability)

The UDKP RELI is a reliability program that is designed to be used with 16 BIT host CPUs. The UDKV is designed to be used with

32 BIT host CPUs. The program verifies the disk drive subsystem for proper operation. The UDKP RELI and UDKV RELI exercise both the disk drive and the controller PCB. The programs will write to either user space or to the diagnostic track only. Only functional error information is provided. Failing FRUs are not listed. Drive error codes are reported. These may be translated to FRU information using 6236 FUNC Program, "HELP" information.

- 6236 FMTR Program (6236/6237 Moving Head Disk Formatter)

#### NOTE

Full format should only be run when there is no alternative. Factory labelled bad blocks will never be fully recovered when formatting in the field.

The 6236 FMTR is a utility program to format and verify, with automatic bad block remapping, the 6236/6237 disk drive media. This program is also used to install any controller microcode updates. Proper operation of the disk drive subsystem is required to run the program. The program will abort operation on any disk drive or controller that encounters a failure. Only functional error information is provided. Failing FRU callouts are not listed. Observe all NOTES and CAUTIONS when running the 6236 FMTR program.

4.4.1 The 6236 Diagnostic Program - 6236 DIAG - In order to run the 6236 DIAG program the system must contain the following equipment:

- MV or ECLIPSE host CPU
- Minimum of 32K of read/write memory
- 6236 or 6237 disk controller
- Teletype or CRT

This program is a hardware diagnostic for the 6236/6237 disk drive subsystem. It will execute only a diagnostic command set. It is designed to exercise the controller with maximum visibility as to the cause of any failure.

The user mode firmware and associated functions are not checked in by this program. The function verification test (6236 FUNC) and the disk reliability test (6236 UDKP RELI or UDKV RELI) should be run after this test to complete the testing of the disk subsystem.

The device code may be 20-76 octal.

- Program Run Time

Refer to Table 4-7 for a listing of the approximate pass time for 6236 DIAG.

- Failing FRUs

Refer to Table 4-8 for a listing of the FRUs that the 6236 DIAG program indicates as failing FRUs.

Table 4-7. 6236 DIAG Program Run Times

TEST PERFORMED	APPROX. RUN TIME MIN:SEC
Controller Only	0:30
Each Unit	1:30

Table 4-8. Failing FRUs Indicated by the 6236 DIAG Program

FRU	LOCATION
Controller PCB	CPU Chassis
Read/Write PCB	Drive Chassis
Control Logic PCB	Drive Chassis
Servo (Position Control) PCB	Drive Chassis
Drive Interface PCB	Drive Chassis
Spindle Control PCB	Drive Chassis
Power Control PCB	Drive Chassis
Power Amplifier PCB	Drive Chassis
Power Bulk (Power Supply) Assy	Drive Chassis
Head Disk Assembly	Drive Chassis

- Operating Modes and Switch Settings

The Switch Register is used to select the program options. The options may be changed or verified by using one of the commands listed in Table 4-9.

Table 4-9. Switch Options

BIT	OCTAL VALUE	BINARY VALUE	INTERPRETATION
1	40000	0 1	Loop on error Skip looping on error
2	20000	0 1	Print to console Inhibit printout to console
3	10000	0 1	Do not print % failure Print % failure
5	02000	0 1	Do not print to line printer Print on the line printer
6	01000	0 1	Do not exit to ODT on error Exit to ODT on error

● Switch Commands

Once the program starts executing the state of any of the bits can be changed by typing keys 1-9, A-F. The program will continue running after updating the options. Each key will complement the state of the bit affiliated with it, thus bit four can be altered by typing key 4. Setting of any bit of location "SWREG" will set bit 0. (Default mode is defined as all bits of "SWREG" set to 0.) Refer to Table 4-10 for a listing of other commands.

Table 4-10. Other Commands

COMMAND	INTERPRETATION
"CR"	A "return" can be typed to continue the program after it is locked into a switch modification mode
CTRL D	This command given at any time will reset "SWREG" to the default mode and restart the program.
CTRL R	This command given at any time will restart the program. Switches are left with the values they had before the command was issued.
CTRL O	This command given at any time will cause the program control to go to ODT.
M	This command given at any time will print the current operating modes.
O	This command given at any time will lock the program into switch modification mode where more than one bit can be changed.

#### 4.4.1.1 Operating Procedure -

1. Load the 6236 DIAG program using the appropriate diagnostic media.
2. The Starting Addresses for the program are:
  - 004 - Controller Microcode 8KW Dump
  - 177 - ODT/Direct Entry Only
  - 200 - Start Diagnostic
3. The program prints "PASS" following each completed pass through the test.

#### 4.4.1.2 Operator Interface - The operator is asked to respond to the following queries:

6236 MOVING HEAD DISK DIAGNOSTIC (6236 DIAG), REV XX

HELP ? (YES/NO)

If help (YES) is requested, the following four categories of help are provided:

- Starting Addresses
- SWREG/Console Control
- Program Commands
- Failing Replaceable Units (FRU) Notes

#### NOTE

Help information is available only on program load.

INITIALIZE ? (YES/NO)

Only asked on program restarts. If "NO" program will bypass the following questions:

SET SWREG AS PER 8.0, HIT CR TO CONTINUE

(Refer to Table 4-9 for information on SWREG)

OCTAL OR HEX DISK/MEMORY DATA MODE (OCT/HEX) -

All addresses, status, and general data will be printed in this mode unless otherwise specified.

DEVICE CODE (OCTAL) =

Enter octal device code of controller.

UNITS TO TEST OR (CR) ONLY FOR CONTROLLER ONLY - 1,2

1,2 represents a possible operator response. A "CR" response will bypass any test requiring a drive ON LINE.

TESTING

Indicates controller test in progress.

TESTING UNIT 1

TESTING UNIT 2

Indicates drives that are being tested.

PASS N

Indicates all tests that have been executed.

4.4.1.3 Program Output/Error Description - When an error is detected the program prints the error Program Counter (PC), Accumulators (AC's) 0, 1, and 2 at the point of the error, plus an option printout. The program goes into a scope loop between the entries to .SETUP and .LOOP allowing the operator to set SWREG. In general, the error PC will point to a call error.

The option printout will be one of the following formats:

A. STANDALONE CONTROLLER TEST FAILURES:

ERROR TYPE

DIC= XXX DIA= XXX DIB= XXX  
COMMAND CODE= XXX DESCRIPTOR MESSAGE  
FAILING MODULE - DISK CONTROLLER

B. STATUS ERRORS:

ERROR TYPE

DIC= XXX DIA= XXX DIB= XXX  
COMMAND CODE= XXX DESCRIPTOR MESSAGE  
AC1(STATUS) SHOULD = AC0  
DESCRIPTIONS OF FAILING STATUS BITS  
PROBABLE FAILING MODULES - (AS PER EACH FAILING BIT)

C. INTERRUPT TIMEOUT

ERROR TYPE

DIC= XXX DIA= XXX DIB= XXX  
COMMAND CODE= XXX DESCRIPTOR MESSAGE  
INTERRUPT TIMEOUT  
PROBABLE FAILING MODULE - CONTROLLER

Additional test significance can be found in the program listing, although it is hoped that a need for the listing will be minimal. SWREG will provide all control over test loop options and printouts.

Data errors will result in the first three good/bad pairs and their addresses being printed along with the total count. In general, each successive assumes all previous test work. Bypassing errors can result in confusing situations in the setup of more complex tests.



4.4.1.4 Octal Debug Tool - This program is equipped with a built in octal debug tool (ODT) which can be accessed by hitting Control O (CTRL O) at any time during the execution of the program (after setting the parameters). Upon entering ODT the address of the location having the next instruction will be typed out.

- ODT Conventions and Symbols

The following conventions are used by ODT:

?            Pressing any illegal key causes the ODT to respond with a "?".

@            ODT is ready and at your service.

- ODT Command Structure

An ODT command is a single teletype character. An ODT command has the following format:

[ARGUMENT] [COMMAND]

An argument may be one of the following:

"EXP"        An octal expression consisting of octal numbers separated by plus (+) or minus (-) signs. Leading zeroes need not be typed.

"ADR"        An address is the same as an expression except that bit 0 is neglected.

- ODT Commands

The locations that can be examined and modified by the user are called cells. These cells are of two types:

1. Internal CPU cells
2. Memory locations

- Opening Cells

The command to open one of the internal registers is of the form "NA" where N is any octal expression between 0 and 7. Refer to Table 4-11 for a listing of Cell Opening Commands.

Table 4-11. Cell Opening Commands

INTERNAL CELL OPENING COMMANDS	
Cell Number	Interpretation
0 - 3	For Accumulators 0 to 3
4	For PC of the next instruction to be executed in the event of a "P" command
5	CPU and TTO Status Bit            Interpretation 15            Status of TTO done flag 14            Status of interrupts (ION flag) 13            Status of carry bit
6	Address of the location having the break point (if any)
7	Instruction at the break point location
OTHER CELL OPENING COMMANDS	
Command	Interpretation
"ADR"/	Open the cell and print its contents
./	Open the cell currently pointed to by the pointer and print its contents
."+ADR"/	Add "ADR" to the pointer, open the cell and print its contents
.-"ADR"/	Subtract "ADR" from the pointer, open the cell and print its contents
"CR"	The return key is used to close the open cell with or without modification
"LF"	Line feed is used to close the open cell with or without modification and to open the succeeding cell
"CTRL"	Close the open cell with or without modification and open the preceding cell
"/"	Close the open cell without modification, and open the cell pointed to by its contents
+"ADR"/	Close the open cell without modification, and open the cell pointed to by its contents + "ADR"
-"ADR"/	Close the open cell without modification, and open the cell pointed to by its contents - "ADR"

- Modification of a Cell

Once a cell has been opened its contents can be modified by typing the new value the cell is to contain in the form of an octal expression followed by a "CR" or "LF". If a + or - is typed as the first character of the expression, the value of the expression is added to or subtracted from the old contents of the cell. The address itself or an expression relative to the address can be deposited by typing a "." or ".+/-octal expression". A rubout command given right after opening a cell allows the modification of its contents as if they were typed just before the command was issued. Refer to Table 4-12 for a listing of other ODT commands.

Table 4-12. Other ODT Commands

COMMAND	INTERPRETATION
"RUBOUT"	This key is used to delete erroneously typed digits. Each time the key is pressed the right-most digit is deleted and echoed on the terminal. If the rubout key is pressed right after opening a cell, it deletes the right-most digit of the cell contents. This allows the modification of the cell as if its contents were typed in just before the key was pressed.
"ADR"B	Insert a breakpoint at location "ADR". Only one breakpoint can be inserted and any entry to ODT after executing a breakpoint will cause it to be deleted.
"D"	Delete the breakpoint if any.
"P"	Restart the execution of the program location pointed by 4A.
"ADR"R	Start executing the program at "ADR" after an I/O -reset.
"K"	Kill the string typed in up to this point in the program. The ODT responds with a "?" and the open cell is closed without modification.
"="	Print the octal value of the input only. This will close any open cells without modification and will not open a cell.
"C"	Core dump, user is asked for starting/ending addresses. Dump will also go to printer if SWREG bit #5 is on.

NOTE

In programs which relocate themselves the user should place breakpoints only in the original program area. If a breakpoint is placed outside this area the results will be unpredictable.

**4.4.2 Function Verification Diagnostic - 6236 FUNC** - In order to run the 6236 FUNC program the system must contain the following equipment:

- MV or ECLIPSE host CPU
- Minimum of 32K read/write memory
- Teletype or CRT and control
- 6236/6237 disk drive controller with one to four 6236/6237 disk drives on each controller

The function verification (FUNC) diagnostic program is a hardware/firmware function verification diagnostic for the 6236/6237 disk drive system. The hardware verification diagnostic (6236 DIAG) program should be run before running this program. Refer to paragraph 4.4.1 for information on the 6236 DIAG program. The device code may be 20-76 octal.

- Program Run Times

Refer to Table 4-13 for a listing of the approximate pass times/unit on an ECLIPSE® S140 CPU.

**Table 4-13. 6236 FUNC Program Run Times**

TEST PERFORMED	APPROX. RUN TIME MIN:SEC
Write Mode/ALL	09:00
Write Mode/DIAG	06:00

- Failing FRUs

Refer to Table 4-14 for a listing of the FRUs that the 6236 FUNC program indicates as failing FRUs.

**Table 4-14. Failing FRUs Indicated by the 6236 FUNC Program**  
(Sheet 1 of 2)

FRU	LOCATION
Controller PCB	CPU Chassis
Read/Write PCB	Drive Chassis
Control Logic PCB	Drive Chassis
Servo (Position Control) PCB	Drive Chassis
Drive Interface PCB	Drive Chassis

Table 4-14. Failing FRUs Indicated by the 6236 FUNC Program  
(Sheet 2 of 2)

FRU	LOCATION
Spindle Control PCB	Drive Chassis
Power Control PCB	Drive Chassis
Power Amplifier PCB	Drive Chassis
Power Bulk (Power Supply) Assy	Drive Chassis
Head Disk Assembly	Drive Chassis

- Operating Modes and Switch Settings

The Switch Register is used to select the program options (not system configurations). The options may be changed or verified by using one of the commands listed in Table 4-15.

Table 4-15. Switch Options

BIT	OCTAL VALUE	BINARY VALUE	INTERPRETATION
1	40000	0 1	Loop on error Skip looping on error
2	20000	0 1	Print to console Inhibit printout to console
3	10000	0 1	Do not print % failure Print % failure
5	02000	0 1	Do not print to line printer Print on the line printer
6	01000	0 1	Do not exit to ODT on error Exit to ODT on error
8	00200	0 1	NA Recalibrate during scope loop Not valid for DIAG track only mode
11(B)	00020	0 1	NA Dump extended return block on hard status errors

● Switch Commands

Once the program starts executing the state of any of the bits can be changed by typing keys 1-9, A-F. The program will continue running after updating the options. Each key will complement the state of the bit affiliated with it, thus bit four can be altered by typing key 4. Setting of any bit of location "SWREG" will set bit 0. (Default mode is defined as all bits of "SWREG" set to 0.) Refer to Table 4-16 for a listing of other commands.

Table 4-16. Other Commands

COMMAND	INTERPRETATION
"CR"	A "return" can be typed to continue the program after it is locked into a switch modification mode.
CTRL D	This command given at any time will reset "SWREG" to the default mode and restart the program.
CTRL R	This command given at any time will restart the program. Switches are left with the values they had before the command was issued.
CTRL O	This command given at any time will cause the program control to go to ODT.
M	This command given at any time will print the current operating modes.
O	This command given at any time will lock the program into switch modification mode where more than one bit can be changed.

4.4.2.1 Operating Procedure/Operator Input -

1. Load the 6236 FUNC program using the appropriate diagnostic media.
2. The starting addresses for the program are:
  - 4 - ECC Correction Exerciser Test
  - 6 - Random Seek Exerciser
  - 177 - ODT/Direct Entry Only
  - 200 - Start Diagnostic
3. The program prints "PASS" following each complete pass through the tests. Random seek exerciser performs 1024. seeks per "PASS" message.

#### 4.4.2.2 Operator Interface -

The operator is asked to respond to the following queries:

6236 MOVING HEAD DISK FUNCTION VERIFICATION TEST  
(6236 FUNC), REV XX

HELP ? (YES/NO)

If help (YES) is requested, the following five categories of help are provided:

- Starting Addresses
- SWREG/Console Control
- Program Commands
- Failing Replaceable Units (FRU) Notes
- Drive Error Code Interpretation

#### NOTE

Help information is available only on program load.

INITIALIZE ? (YES/NO)

Only asked on program restarts. If "NO" program will bypass the following questions.

SET SWREG AS PER 8.0 (Table 4-15), HIT CR TO CONTINUE

DECIMAL,HEX, OCTAL DISK/MEMORY DATA MODE (DEC/HEX/OCT) ? -

Controls all further disk/memory data input/output unless specified otherwise -

DEVICE CODE (OCTAL) =

Enter octal device code of controller.

UNITS TO TEST - 1,2

1,2 represents a possible operator response.

354,TBD MBbytes (354) -

UNIT: 1 - 354

UNIT: 2 - 354

DRIVE TEST MODE - DIAGNOSTIC TRACK ONLY, OR  
ALL TRACKS (DIAG,ALL) -

UNIT: 1 - ALL  
UNIT: 2 - ALL

TESTING UNITS 1,2

Indicates test in progress.

4.4.2.3 Program Output/Error Description - When an error is detected the program prints the error PC, ACs 0,1, and 2 at the point of the error, plus an option printout. The program goes into a scope loop between the entries to .SETUP and .LOOP allowing the operator to set SWPAK. In general the error PC will point to a call error.

#### NOTE

Some scope loops will require a recalibrate to initialize the disk drive following a failure. Set SWPAK 8 = 1 to introduce the recalibrate to the unit under test.

The option printout will be one of the following formats:

#### A. STANDALONE CONTROLLER TEST FAILURES-

TYPE OF ERROR            COMMAND CODE = XXX        DESCRIPTIVE MESSAGE  
FAILING MODULE - DISK CONTROLLER

#### B. STATUS ERRORS

MODE        UNIT        #        DEVICE CODE =        #        DATA  
LOGICAL DISK ADDRESS = #            SECTORS TRANSFERRED = #  
PHYSICAL DISK ADDRESS  
CYL        #        HEAD        #        SECTOR        #  
AC1(STATUS) SHOULD =AC0  
DESCRIPTIONS OF FAILING STATUS BITS  
PROBABLE FAILING MODULES = (AS PER EACH FAILING BIT)

#### C. INTERRUPT TIMEOUT

MODE        UNIT        #        DEVICE CODE =        #        DATA  
LOGICAL DISK ADDRESS = XXX        SECTORS DONE = XXX  
INTERRUPT TIMEOUT  
PROBABLE FAILING MODULES - DISK CONTROLLER

Additional test significance can be found in the program listing, although it is hoped that a need for the listing will be minimal. SWREG will provide all control over test loop options and printouts.

Data errors will result in the first three good/bad pairs and their addresses being printed along with the total count. If an ECC error is detected, the call EHECC will acknowledge the fact and return to the main test for the data compare. Printouts result on the first error pass only. As the check routine checks the entire read buffer, any error accompanied by an ECC error, terminating the read, may cause all data in succeeding sectors to appear bad.



Tests that perform a recalibrate may have a two second delay built into the scope loop. Set SWPAK 8 = 1 to introduce an additional one second delay during the scope loop.

In general each successive test assumes all previous tests' work. Bypassing errors can result in confusing situations in the setup of more complex tests.

4.4.3 UDKP RELI and UDKV RELI Reliability Programs - The UDKP RELI (reliability program) is designed to run on 16 BIT ECLIPSE CPUs and the UDKV RELI (reliability program) is designed to run on 32 BIT CPUs. The following subsections describe the programs.

- UDKP RELI System Requirements

In order to run the UDKP RELI program the system must contain the following equipment:

1. ECLIPSE Family Host CPU
2. 32K read/write memory
3. Teletype or CRT
4. One to eight 6236/6237 disk drive controllers with one to four 6236 disk drives on each controller

- UDKV RELI System Requirements

In order to run the UDKV RELI program the system must contain the following equipment:

1. MV Family Host CPU
2. 128K read/write memory
3. Teletype or CRT
4. One to eight 6236/6237 disk drive controllers with one to four 6236 disk drives on each controller.

- UDKP RELI Program Run Times

Refer to Table 4-17 for a listing of approximate program run times for an ECLIPSE S140 with 256K of memory. The controller modes are optimization (ON), modified bits (ON), and alternate ports (OFF).

Table 4-17. UDKP RELI Program Run Times

STARTING/DATA ADDRESS/PATTERN	APPROX. RUN TIME HR:MIN:SEC
SA 501/RANDOM*	18:00
SA 501/ALT**	11:00
SA 502/RANDOM	23:30
SA 502/ALT	16:00
SA 506	03:00
SA 507	04:00
SA 511	20:00
SA 505	02:55:00
* 1-3 Write/Read CBs per list	
** 1 Write/Read per CB per list	
<p><b>NOTE:</b> Data patterns ALO,ALZ,PAT,VRL,VRC,VRD, and ROT should exhibit the same approximate run times as ALT. Data patterns FLO,FLZ, and VAR should exhibit the same as data pattern RAN. Above times with default controller parameters.</p>	

● UDKV RELI Program Run Times

Refer to Table 4-18 for a listing of approximate program run times for an MV CPU with 512K of memory. The controller modes are optimization (ON), modified bits (ON), and alternate ports (OFF).

Table 4-18. UDKV RELI Program Run Times

STARTING/DATA ADDRESS/PATTERN	APPROX. RUN TIME HR:MIN:SEC
SA 501/RANDOM*	21:00
SA 501/ALT**	12:00
SA 502/RANDOM	12:00
SA 502/ALT	12:00
SA 506	03:00
SA 507	04:00
SA 511	15:00
SA 505	02:20:00
* 1-3 Write/Read CBs per list	
** 1 Write/Read per CB per list	
NOTE: Data patterns ALO,ALZ,PAT,VRL,VRC,VRD,and ROT should exhibit the same approximate run times as ALT. Data patterns FLO,FLZ, and VAR should exhibit the same as data pattern RAN. Above times with default controller parameters.	

4.4.3.1 UDKP/UDKV RELI Program Description - The 6236 moving disk (UDKP/UDKV RELI) program is a maintenance program designed to test and exercise one to eight 6236/6237 disk drive subsystems, with one to four disk drives each. The program device code(s) may be any device code 20-76 octal.

The program is a collection of tests designed to create maximum mechanical and electronic disk activity for long term testing and failure analysis. The disk drives may be shared by two computers, in which case this program may be running in both computers.

The reliability program consists of a series of separate tests. Each test is designed to achieve specific goals within the scope of the program. All the tests share a common structure and interface. Each sub-test contains local interface, where necessary, to communicate its function. The major sub-tests may be executed consecutively or individually at the operators' discretion. The default starting address allows the operator to select the desired test to be performed. The program requires initial operator intervention to determine parameters and runtime options for all starting addresses.

At initial program load, a help file is available for the operator. The file will reside in the buffer area which will be overlaid by the data patterns. Under operator control, a description of the different test programs and operating parameters will be printed on the system console and/or line printer.

4.4.3.2 Program Description/Starting Addresses - The reliability program contains several different test programs. Each program has its own starting address. A description of each starting address is listed below:

(SA 500) RELIABILITY TEST

A random number generator is used to select a disk drive, cylinder, head, beginning sector, (or logical address) and number of consecutive sectors. Random data is generated, written, and read. The sequence is repeated indefinitely. A partitioning scheme will break a large disk transfer into smaller segments, which will be executed with a longer command block list.

(SA 501) RELIABILITY TEST WITH OPTIONS

Same as SA 500, except the operator is given options on data patterns (refer to Table 4-19) and may choose a constant sector count by entering a number. Any letter response will get the random function. If a constant sector is selected, no partitioning will be done (i.e. the list will consist of one write and read block).

The operator may also specify that each list consist of only one write and read block. A "NO" response will get 1 to 3 partitions per write and read.

The operator is also asked to respond to jitter option (YES/NO). IF "YES", a random delay (0-40,50 ms) is inserted into the background loop to create a more asynchronous disk I/O loop, a "YES" response will also result in a longer test runtime.

The operator may also set the read only switch (SWREG 8). If the data is unknown or a non-constant data pattern, SW9 should also be set to inhibit data checking (refer to Table 4-21).

(SA 502) INCREMENTAL DISK ADDRESS TEST

Operator is given the option on data (refer to Table 4-19). Requested data is first written over the entire pack. The data is read from all sectors. This insures that all disk pack blocks are useable and are formatted properly. The test is repeated for all ready discs, and pass is printed. The sequence is repeated indefinitely.

#### NOTE

SWPAK 8=1, puts the program into read only mode for SAs 501 and 502 only. If SA 501, data must be constant (refer to Table 4-19). All numbers entered must be in octal. Any non-octal number is treated as a letter. Any letter input for number of sectors gets random function in the reliability test with options.

#### (SA 503) COMMAND STRING INTERPRETER

As a troubleshooting aid the maintenance engineer may type in a test loop. The following two questions must be answered upon starting at SA 503:

#### PHYSICAL OR LOGICAL MODE (PHY/LOG) ?

If physical mode is selected, "ADDRESS" in command string option refers to "CYLINDER", "HEAD", "SECTOR".

If logical mode is selected "ADDRESS" in command string refers to a 32. bit logical address.

#### NOTE

Physical "ADDRESS" entered via the physical address mode are converted to an approximate logical address which assumes no defective sectors for that cylinder. Therefore the actual head/sector address may vary from the address entered by 0 -/+ 16. sectors. Physical cylinder 0 is NOT accessible.

#### HEX,OCTAL OR DECIMAL MODE (DEC/HEX/OCT) ?

Refers to the mode in which the above addresses are entered, and how they will be printed out.

The following three questions will be asked on any SA 503 start, upon completion of a command string, or upon termination of a command string by an "R" typed.

#### UNIT

Type unit number or carriage return (CR) to use the previous entry.

#### DATA

Select one of the data patterns listed in Table 4-19:

Table 4-19. Data Patterns

COMMAND	DATA PATTERN
RAN	RANDOM
ALO	ALL ONES
ALZ	ALL ZEROES
PAT	155555 PATTERN
VRL	HEX 2727 PATTERN
VRB	HEX 2525 PATTERN
VRC	HEX 1F1F PATTERN
VRD	HEX F6F6 PATTERN
ROT	HEX 2727 PATTERN ROTATED ON SUCCESSIVE PASSES
ALT	52525 PATTERN*
FLO	FLOATING ZERO PATTERN
FLZ	FLOATING ZERO PATTERN
ADR	TWO WORD LOGICAL ADDRESS
VAR	EXISTING WORDS ENTERED AS PREVIOUSLY DESCRIBED
<p>*NOTE: Alternately enters a string of up to seven octal 16 bit words to be used as data. The words entered are used repeatedly to make up a sector block. Type CR to use the previous entry.</p>	

COMMAND STRING

The command string may consist of any one or combinations of the commands listed in Table 4-20.

Table 4-20. UDKP/UDKV RELI Command String (Sheet 1 of 2)

COMMAND	DEFINITION
READ "ADDRESS", # OF SECTORS	Read
WRITE "ADDRESS", # OF SECTORS	Write
VERIFY "ADDRESS", # OF SECTORS	Read/Verify
WVER "ADDRESS", # OF SECTORS	Write/Verify
RVSD "ADDRESS", # OF SECTORS	Read/Verify single word

Table 4-20. UDKP/UDKV RELI Command String (Sheet 2 of 2)

COMMAND	DEFINITION
WVSWD "ADDRESS", # OF SECTORS	Write/Verify single word
RMBM "ADDRESS", # OF SECTORS	Read modified bit map
WMBM "ADDRESS", # OF SECTORS	Write modified bit map (after RMBM)
RDHD "ADDRESS", # OF SECTORS	Read header
WSWD "ADDRESS", # OF SECTORS	Write single word
LOOP	Loop to CSI start or to LR
LR	Loop return (begin loop here)
NOTE: In physical mode, "ADDRESS" = Cylinder, Head, Sector In logical mode, "ADDRESS" = 32 bit logical address	

NOTE

Either a space or a comma may be used as an argument delimiter. Each response is terminated by typing a carriage return (CR). If more space is needed on a line, type Line Feed to space to the next line. The word "SAME" used with read or write, will cause the previous disk address parameters to be used.

An "R" typed while a string is being executed will cause the program to return to the command string start. The escape key will bypass the unit and data prompts to the command string prompt.

The following example would cause UNIT 1 to seek to cylinder 50, repeatedly write sectors 2 and 3 of head 5, read it back and check. Data is specified as alternate words or zeros then ones. (This example is in physical mode.)

```
UNIT: 1
DATA: 0,177777
COMMAND STRING: WRITE 50,5,2,2 READ SAME LOOP
```

(SA 505) RUNALL

The program alternates between the programs described in SA 501 (four DATA PATTERNS - RAN,VRL,FLZ,FLO); SA 511 (two ODD/EVEN COMBINATIONS - VRL/VRB,VRC/VRD); SA 502 (four DATA PATTERNS - RAN,RAN1,ALT1,ZEROES) and SA 507, and in that order.

#### NOTE

RANDOM TESTS (SA 501) are run with different list options. The first pattern (RAN) is run with multiple write/read blocks per list and with two outstanding lists per unit. The remaining three patterns are run with one write and read CB per list and one list per unit.

#### (SA 506) SEEK EXERCISER

The program provides a seek scan sequence converging from the extreme outermost tracks into the adjacent track in the center, diverging again to the extremes.

#### (SA 507) RANDOM SEEK EXERCISER

The program provides a random seek sequence of 5000. seeks.

All seeks are followed by one sector read but with no data check. All seeks are timed with MAX,MIN and AVE. Times being logged in ms. Seek paths for MAX,MIN value are also logged.

#### (SA 510) ERROR COUNT/LOG RECOVERY

In the event a program was stopped during a run, the error logs may be recovered at this starting address.

#### NOTE

Error log recovery must be done before any program restart because program initialization zeros all logs.

#### (SA 511) ODD/EVEN CYLINDER ADDRESS TEST

This SA is similar to SA 502, except that the write/reads are done in the following sequence:

#### NOTE

The operator is given the option of specifying the two data words (A) and (B).

- (1) WRITE ODD CYLINDERS WITH DATA WORD (A)
- (2) WRITE EVEN CYLINDERS WITH DATA WORD (B)
- (3) READ ODD CYLINDERS
- (4) WRITE ODD CYLINDERS WITH DATA WORD (A)
- (5) READ EVEN CYLINDERS
- (6) WRITE EVEN CYLINDERS WITH DATA WORD (B)
- (7) GO TO STEP (3)



4.4.3.3 Switch Settings - The Switch Register is used to select the program options. The options may be changed or verified by using one of the commands listed in Table 4-21.

Table 4-21. Switch Options (Sheet 1 of 2)

BIT	OCTAL VALUE	BINARY VALUE	INTERPRETATION
1	40000	0 1	Loop on error Skip looping on error
2	20000	0 1	Print to console Inhibit print out to console
4	04000	0 1	Print pass Do not print pass
5	02000	0 1	Do not print to line printer Print on the line printer
6	01000	0 1	Do not exit to ODT on error Exit to ODT on error Hit P to continue
7	00400	0 1	NA Do verify after write (SA 502 only)
8	00200	0 1	NA For Read only mode (SA 501,502) with data checking Write protect options disable data checking
9	00100	0 1	NA Bypass data check
10 (A)	00040	0 1	Print all soft errors Do not print soft errors
11 (B)	00020	0 1	NA Dump extended return block on hard status errors
12 (C)	00010	0 1	NA Exit to ODT on drive error prior to recovery recalibrate operation hit P to continue

Table 4-21. Switch Options (Sheet 2 of 2)

BIT	OCTAL VALUE	BINARY VALUE	INTERPRETATION
13 (D)	00004	0 1	NA Print I/O trace on error last 5 I/O call PC's + commands
14 (E)	00002	0 1	NA Print error summary on pass
15 (F)	00001	0 1	Print each error once only Print all errors on retries

● Switch Commands

Once the program starts executing the state of any of the bits can be changed by typing keys 1-9, A-F. The program will continue running after updating the options. Each key will complement the state of the bit affiliated with it, thus bit four can be altered by typing key 4. Setting of any bit of location "SWREG" will set bit 0. (Default mode is defined as all bits of "SWREG" set to 0.) Refer to Table 4-22 for a listing of other commands.

Table 4-22. Other Commands

COMMAND	INTERPRETATION
"CR"	A "return" can be typed to continue the program after it is locked into a switch modification mode.
CTRL D	This command given at any time will reset "SWREG" to the default mode and restart the program.
CTRL R	This command given at any time will restart the program. Switches are left with the values they had before the command was issued.
CTRL O	This command given at any time will cause the program control to go to ODT.
M	This command given at any time will print the current operating modes.
O	This command given at any time will lock the program into switch modification mode where more than one bit can be changed.

#### 4.4.3.4 Operating Procedure

1. Verify drive(s) are ready ON LINE.
2. Load the program using the appropriate diagnostic media.
3. Start the program at one of the following sub-test addresses (Refer to Table 4-23):

Table 4-23. UDKP/UDKV Starting Addresses

ADDRESS	FUNCTION
177	Octal Debugger - Direct Entry
200	Select Type of Test / ADES Start
500	Random Reliability Test
501	Random Reliability Test, Operator Options
502	Incremental Disk Address Test
503	Command String Interpreter
504	Not Used
505	Runall
506	Converging/Diverging Seek Exerciser
510	Statistics/Error Log Recovery
511	Odd/Even Cylinder Address Test

- Program Special Notes/Features

1. A CR only response to UNIT numbers, etc. will leave information in the previous state.
2. The program will account for up to a maximum of  $2^{*}31$  sectors written or read. Special test runs exceeding this facility will require an operator's test log to augment software accounting.  $2^{*}31$  sectors = approximately  $5.5 * 10^{*}11$  words.
3. READ, WRITE operations are timed by special routines. When the program is first started, the timing routines will test for the presence of a real time clock (RTC) to derive timing from it. If no RTC is present the program will type "TTO BAUD RATE". This message refers to the baud rate of the console terminal (device 10 and 11). Type in the baud rate. If a typing error occurs in the number string (before the CR), type a non-numeric character and the request for the baud rate will be repeated. If the CR has been given after a typing error, restart the program.

#### 4.4.3.5 Operator Interface - The operator is asked to respond to the following queries:

XXX MOVING HEAD DISK RELIABILITY, REV XX, TEST # XXX

HELP ? (YES/NO) -

If help is requested, the following six categories of help are provided:

- Starting Address
- SWREG/Console Control
- Data Patterns
- Command String
- Command String Notes
- Miscellaneous Notes

#### NOTE

HELP information is only available on program load.

6236 MOVING HEAD DISK RELIABILITY (16 BIT SYSTEMS)  
UDKP RELI, SV, REV XX STARTING ADDRESS = XXX

WRITE PROTECT DISK (YES/NO) ?

Asked for SAs 500,501,502. If answer YES, no writing or data checking will be done by the program. If READ ONLY with data checking is desired, use SW(8) on SA 502.

If SA 200,505, or 511 is selected, a warning will be issued that the pack will be written to.

SET SWPAK AS PER 8.0 (Table 4-21), HIT (CR) TO CONTINUE

TTY BAUD RATE (DEC. #) =

Only asked if RTC is not present for program timing.

INITIALIZE (YES/NO) ?

If "NO" the following questions are bypassed.

DECIMAL, HEX, OCTAL DISK/MEMORY DATA MODE (DEC/HEX/OCT) ?

Controls all further operator numerical inputs and program outputs unless otherwise specified.

START TIME ? MON, DAY, YEAR HR, MIN

ENTER DEVICE CODES (1-8 OCTAL #'s) - 24

DEVICE CODE - 24

UNITS TO TEST - 1,2

1,2 represents a possible operator response.

354, (TBD) MBYTES (354) ?

UNIT 1 - 354

UNIT 2 - 354

ENTER MIN/MAX LOGICAL DISK ADDRESSES (2 #'S) -  
UNIT: 0

ERRORS PER UNIT TO TEST

Number of errors per unit before testing on a unit stops (decimal).

CHANGE DEFAULT CONTROLLER PARAMETERS (YES/NO) ?

If "Yes", the following questions are asked.  
If "No", the last or original default values are used.

SELECT MAPPING OPTION (0,1,2 (CR))

- (0) NO MAPPING
- (1) SOFTWARE PREMAPPING
- (2) CONTROLLER PHYSICAL REMAPPING (DEFAULT)
- (3) BMC UPSTREAM LOADING (LEVEL 1) (UDKV RELI)
- (3) BMC UPSTREAM LOADING (LEVEL 2) (UDKV RELI)

UNIT RETRIES (0-127./DEFAULT=4) -

The maximum number of times the controller will try to execute a CB for a drive that is reporting an error.

CONTROLLER RETRIES (0-127./DEFAULT=4) -

The maximum number of times the controller will try to execute a CB with controller errors occurring (timeout, ECC, etc.)

READ WITH ECC RETRIES (0-127./DEFAULT=4) -

The maximum number of correction retries the controller will attempt.

DO YOU WANT TO DEFAULT FOR:  
OPTIMIZATION (ON),

Optimization (ON) improves overall performance.

MODIFIED BITS (ON),

If (ON), a write operation will set the modified bit.

If (OFF), a write operation will clear the modified bit.

ALT. PORTS (OFF) (YES/NO) ?

Set (ON) for dual operation

INITIALIZING

DEVICE CODE (OCT) - 24

CONTROL PROGRAM REV NUMBER = 0

UNIT: 0 DRIVE CONTROL PROGRAM REV = 7

TESTING

DEVICE CODE (OCT) -24 UNITS 0,

4.4.3.6 Operator Controlled Program Printouts - Refer to Table 4-24 for a listing of operator controlled printouts:

Table 4-24. Operator Controlled Printouts

COMMAND	INTERPRETATION
L	First 100. Data, or 50. Address Error Addresses.
S	Seek Timing Statistics (SA 506,507 only)
W	Sectors Written/Read plus error counts
CTRL S	Inhibits the above printouts. Any subsequent key resumes the printout.
NOTE: Any other character typed during above printouts will terminate printout.	

4.4.3.7 Program Output/Error Description - All errors are identified, counted, and the program is routed via base to a call to CKSW. on the basis of switch settings (refer to Table 4-21). The program will go into a scope loop, or proceed, depending on the SWPAK settings.

Upon loss of ready in a single drive configuration, the program will printout the appropriate error message and will not proceed until ready is returned. If multiple drives exist, the program will continue with the remaining drives. If the down drive is placed back ON LINE, the program will resume testing that drive.

● I/O Faults - General Description

Following "DONE" on any command block list operation, the DIC is checked to determine the nature of the interrupt, and to determine whether or not the controller has detected any error condition. If a normal CB completion is indicated, all CB status's in the completed list are checked for normal status. If any CB status indicated an error condition, an error printout in the format listed below is triggered, with a bit by bit interpretation of the failing CB status. A trailing message will indicate that the DIC failed to indicate the fault.

If the DIC indicated a controller error condition, an error printout of the format listed below will be triggered, followed by an interpretation of the DIC word.

If the DIC indicated a CB execution error, an extended CB return block is requested from the controller. After the return block is read into memory each failing bit in the hard/soft status and unit detected will cause a corresponding count to be incremented in the error log. All drive related faults will cause a recalibrate to be performed in the error handler.

If SW(B) = 1, the extended return block will be dumped as per the current disk/memory data mode. If an address error - repeat the I/O, if test passes the second time, increment the soft address error count and do a normal return otherwise increment the hard address error count and do an error return.

If a hard cylinder address error occurs, a read on an adjacent head will be attempted to determine whether the fault should be classed as a seek error or an address error. The first 50. address errors will have their addresses logged.

- Read Errors

All read errors with the exception of data related errors are handled the same as described for the write operations.

#### DATA ERRORS:

Data is reread 3x (4x if ECC undetected). If program is in write/read mode and data is bad all four tries, a hard error count is incremented and an error return is taken. If data is good on any of the four tries, a soft error count is incremented and a normal return is taken. The disk address of all data problems will be printed and the first 100. will be logged. The first three good/bad word pairs and respective addresses will be printed.

If SWREG(9)=1 (Bypass Data Check) or in program write protect mode, hard or soft data errors will be determined by ECC status.

#### ECC (Error Correction Code) ANALYSIS:

All read passes will have ECC. The results are logged as per the following four categories:

1. ECC CORRECTED - The ECC detected and successfully corrected the data error.
2. NON-CORRECTABLE ECC - The ECC detected and correctly diagnosed the error pattern as uncorrectable.
3. ECC UNDETECTED - The ECC failed to detect a DATA ERROR. This may be a malfunction of the ECC logic, but it is more likely one of the following problems:
  - A failure of the drive or controller to write a sector
  - A failure in the DCH interface, controller, or memory subsystem.

4. ECC FAILED - Two conditions may fall into this category:

- An ECC error was detected but with no accompanying data error. This may be due to the data error being confined to the ECC or data checksum words themselves. This type of error should represent only a very small percentage of the data errors (<2%-large sample). If a significantly higher percentage of this error results, an ECC problem would be indicated.
- An ECC error was detected, but the ECC either failed to correct a correctable error, or tried to correct an uncorrectable error. This condition may result when the data checksum fails after an ECC correction is attempted.

● Program Error Outputs

One of the following error reports is printed whenever an error is detected. All N values are in octal.

DEVICE STATUS ERRORS

```

`MODE` UNIT:  `N`      TEST #  `N`
LOGICAL DISK ADDRESS
START  `N`      COUNT  `N`      END      `N`
ENDING PHYSICAL ADDRESS
CYL-  `N`      HEAD  `N`      SECT  `N`      #SECT  `N`
(XXX) STATUS =  `N`
`DESCRIPTIVE MESSAGES FOR ALL FAILING BITS`
    
```

\*\* # SECT = NO OF SECTORS COMPLETED PRIOR TO ERROR.

DATA/ECC ERRORS

```

`MODE` UNIT:  `N`      TEST #  `N`
LOGICAL DISK ADDRESS
START  `N`      COUNT  `N`      END      `N`
ENDING PHYSICAL ADDRESS
CYL-  `N`      HEAD  `N`      SECT  `N`      #SECT  `N`
HARD STATUS =  `N`
ECC DETECTED ERROR
ADDR  WORD #  GOOD      BAD
22002  4      133333  133233
22004  6      133333  133311
COUNT  2
    
```

\*\*\*GOOD/BAD DATA PRINTED FOR FIRST THREE ERRORS ONLY

IF DATA ERROR WAS NOT ECC DETECTED, LINE DEFINING STATUS WILL NOT APPEAR, AND FOLLOWING PRINTOUT WILL BE APPENDED IF RUNNING MAPPED.



MAP TYPE	USER (A OR B)	BMC MAP # (IF BMC USED)	READ LOG
1K	PHYS 1K	DCH LOGICAL WRITE LOG 1K	PHYS
1K	DCH LOGICAL		

\*\*\*NO WRITE DATA IF IN READ ONLY MODE

- Statistics

Type "W" during random test to get a report of the number of sectors written (and/or) read, plus error counts in decimal.

Type "L" for the first 100. disk addresses of bad sectors and data errors, and first 50. of address errors and seek errors (seek path). If address errors are encountered more than once (1st pass), a count of up to 256. will be recorded in the log. Also a count of up to 15. hard errors will be recorded. This count will be a subset of the first count.

**NOTE**

The address information will be operator specified and the counts will be in decimal.

Type "S" for seek timing statistics if running either seek exerciser.

**NOTE**

The program will account for up to a maximum of  $2^{*}31$  sectors written or read. Special test runs exceeding this facility will require an operator's test log to augment software accounting.  $2^{*}31$  sectors = approximately  $5.5 * 10^{**}11$  words.

#### 4.4.4 6236 FMTR (Formatter) Program -

**CAUTION**

Before performing any 6236 FMTR operations the entire disk must be backed-up or the data that is written on the disk will be destroyed.

**CAUTION**

The 6236 FMTR program allows the user access to physical cylinder #0. The subsystem microcode resides on physical cylinder #0. If the data on physical cylinder #0 is destroyed, it must be replaced. The microcode can be loaded by using the 6236 FMTR "Install Firmware" command (option G). An error condition will result if the microcode is not loaded to physical cylinder #0. The procedure for using "Install Firmware" is as follows:

1. Reload the 6236 FMTR program.
2. Select option (G) INSTALL FIRMWARE.

#### CAUTION

Existing bad sector information will be destroyed if a format operation is performed. Be sure to obtain a copy of the existing bad sector information prior to executing the format. Any bad sectors in the original list which were not found by the formatter should be manually flagged bad, using the "Specify Defects" option.

#### CAUTION

Prior to running any formatter program the top cover must be installed. The disk drive must have temperature stabilized for a one hour time period with the top cover installed.

#### NOTE

"Install Firmware", if used, must be done before any other operations because all firmware resides in a scratch area and is only available on program load.

#### NOTE

The 6236/6237 disk drive is shipped with a "Bad Sector Map". (A listing of existing "Bad Sectors".) The map can be used as reference when running the 6236 FMTR program. A "Bad Sector Map" can be created by using the 6236 FMTR option: (F) GET CURRENT DEFECT SECTORS.

#### ● 6236 FMTR Program Formatting Options

The following formats can be performed on the 6236/6237 disk drive:

1. Single Track Format - worst case patterns, (one pattern for short term verify) add-on only. (Will not change the status of the existing "Bad Sectors", but will add to existing Bad Sector Map.) 6236 FMTR options: (D) LONG VERIFY or (E) SHORT VERIFY. Min/Max cylinders to the cylinder desired.
2. Full Pack Format - worst case patterns (one pattern for short term verify), add-on only. (Will not change the status of the existing "Bad Sectors", but will add to existing Bad Sector Map.) 6236 FMTR options: (D) LONG VERIFY or (E) SHORT VERIFY.
3. Forced Add-On Only - user lists the sector(s) that will be added to the existing "Bad Sectors". This will update the disk drive "Bad Sector Map". 6236 FMTR option: (A) SPECIFY DEFECTS CLI

4. Full Pack Format - tests and formats the entire pack, using the worst case patterns. Only those locations that the formatter program designates as being defective will be listed in the disk drive "Bad Sector Map". 6236 FMTR option: (B) SHORT FORMAT or (C) LONG FORMAT

4.4.4.1 6236 FMTR Program Description - In order to run the 6236 FMTR program the system must contain the following equipment:

- MV or ECLIPSE host CPU
- 32K read/write memory
- Teletype or CRT
- One to eight 6236/6237 disk drive controllers with one to four 6236/6237 disk drives on each controller

The 6236 moving head disk formatter program is a maintenance program designed to format and to provide detailed media defect information for one to eight 6236/6237 disk drive subsystems, with one to four disk drives. The program device codes may be any device codes 20 to 76 octal.

The formatter program consists of separate selectable routines. Each routine is designed to achieve specific goals within the scope of the program. All the routines share a common structure and interface. Each subroutine contains local interface, where necessary, to communicate its function. The major subroutines may be executed consecutively or individually at the operator's discretion. The default starting address allows the operator to select the desired routine to be performed. The program requires initial operator intervention to determine parameters and runtime options for all starting addresses.

At initial program load, a HELP file will be available for the operator. The file will reside in the data buffer, which will be overlaid by the data patterns. Under operator control, a description of the different routine programs and operating parameters will be printed on the system console and/or line printer.

The program is designed to achieve maximum data throughput by utilizing I/O time to set up the next transfer and process the results of completed transfers while executing the current transfer. This process is achieved by a foreground/background scheme. Each process is initiated by the preceding process. Data generation and check functions are optimized when possible by utilizing a multiple buffering technique.

The primary purpose of the formatter program is to initialize the header and data fields of the 6236 disk drive media, and to identify and map out any defective sectors.

The secondary purpose is to provide the install function, which loads the normal user control program to the required cylinder on the disk drive. It is this code, that will be booted into the controller upon receipt of the "BEGIN" command.

4.4.4.2 Switch Settings - The Switch Register is used to select the program options (not system configuration). The options can be changed or verified by using one of the commands listed in Table 4-25.

Table 4-25. 6236 FMTR Program Switch Options

BIT	OCTAL VALUE	BINARY VALUE	INTERPRETATION
1	40000	0 1	Loop on error Abort failing unit/controller and continue with remaining units
2	20000	0 1	Print to console Inhibit printout to console
4	04000	0 1	Print pass Do not print pass
5	02000	0 1	Do not print to line printer Print on the line printer
6	01000	0 1	Do not exit to ODT on error Exit to ODT on error Type P to cont
11(B)	00020	0 1	Disable new defective sector printouts Enable new defective sector printouts

● Switch Commands

Once the program starts executing the state of any of the bits can be changed by typing keys 1-9, A-F. The program will continue running after updating the options. Each key will complement the state of the bit affiliated with it, thus bit four can be altered by typing key 4. Setting of any bit of location "SWREG" will set bit 0. (Default mode is defined as all bits of "SWREG" set to 0.) Refer to Table 4-26 for a listing of other commands.

Table 4-26. 6236 FMTR Program - Other Commands

COMMAND	INTERPRETATION
"CR"	A "return" can be typed to continue the program after it is locked into a switch modification mode.
CTRL D	This command given at any time will reset "SWREG" to the default mode and restart the program.
CTRL R	This command given at any time will restart the program. Switches are left with the values they had before the command was issued.
CTRL O	This command given at any time will cause the program control to go to ODT.
M	This command given at any time will print the current operating modes.
O	This command given at any time will lock the program into switch modification mode where more than one bit can be changed.

#### 4.4.4.3 Operating Procedure

1. Verify drive(s) are ready ON LINE.
2. Load 6236 FMTR using the appropriate diagnostic media.
3. Start the program at one of the following sub-test addresses (refer to Table 2-27):

Table 4-27. FMTR Program Starting Address

STARTING ADDRESS	FUNCTION
177	Octal Debugger - Direct Entry
200	Formatter Start with Menu
500	Formatter Start with Menu
501	Defective Sector Log Recovery

#### 4.4.4.4 Operator Interface - The operator is asked to respond to the following queries:

6236 MOVING HEAD DISK FORMATTER PROGRAM  
(6236\_FMTR), REV XX,

HELP ? (YES/NO) -

If help is requested, the following two categories of help are provided:

1. Starting Address (refer to Table 4-27)
2. SWREG/Console Control (refer to Table 4-25)

**NOTE**

HELP information is only available on program load.

SET SWPAK AS PER 8.0 (Table 4-25), HIT (CR) TO CONTINUE

TTY BAUD RATE (DEC. #) =

Only asked if RTC is not present for program timing.

INITIALIZE (YES/NO) ?

If "NO" the following questions are bypassed.

DECIMAL, HEX, OCTAL DISK/MEMORY DATA MODE (DEC/HEX/OCT) ?

Controls all further operator numerical inputs and program outputs unless otherwise specified.

START TIME ? MON, DAY, YEAR HR, MIN

ENTER DEVICE CODES (1-8 OCTAL #'S) - 24

DEVICE CODE - 24

UNITS TO TEST - 1,2

1,2 represents a possible operator response.

DRIVE TYPE (TBD)

UNIT 1 -

UNIT 2 -

ENTER MIN/MAX CYLINDERS (2 #'S) -

UNIT 1 - 0,1000 (NOTE: Carriage Return ("CR"), selects all cylinders)

UNIT 2 - 10,20

**NOTE**

Above repeated if second device code is selected.

SELECT (A-G) AND CR

### CAUTION

Before performing any 6236 FMTR operations the entire disk must be backed-up or the data that is written on the disk will be destroyed.

- (A) SPECIFY DEFECT CLI
- (B) SHORT FORMAT/INCLUDES 1 PATTERN VERIFY
- (C) LONG FORMAT/INCLUDES N 16. PATTERN VERIFIES
- (D) LONG VERIFY/16. PATTERN VERIFIES
- (E) SHORT VERIFY/ 1 PATTERN VERIFIES
- (F) GET CURRENT DEFECTIVE SECTORS
- (G) INSTALL CONTROL FIRMWARE

### CAUTION

Install, if used must be done before any other operations, as all firmware resides in a scratch area and is only available on program load.

ENTER ANY COMMENTS/USE (NL) FOR NEW LINES, (CR) TO EXIT

Allows user to enter formatter notes. Notes will appear in command (F) GET CURRENT DEFECTIVE SECTORS listing.

#### FORMATTING

DEVICE CODE - 24

UNITS 1,2

4.4.4.5 Operator Controlled Program Printouts - Refer to Table 4-28 for a listing of operator controlled printouts:

Table 4-28. Operator Controlled Printouts

COMMAND	INTERPRETATION
L	Current Defective Sector Log
CTRL S	Inhibits the above printouts. Any subsequent key resumes the printout.
<b>NOTE:</b> Any other character typed during above printouts will terminate printout.	

4.4.4.6 Program Output/Error Description - All errors, with the exception of defective sector information reported by the format commands, are considered fatal to the unit under test. The type of error as reported by the DIC will be reported, as well as any additional controller or unit status. The unit will be removed from the active list, and formatting will continue on any remaining units for that controller.

If SW1=0, the program will loop on the program error condition. Otherwise, the program will continue with the remaining error free units.

- Program Error reports

Program error reports appear in the following format:

(TYPE OF DIC ERROR)  
COMMAND CODE =XXX COMMAND DESCRIPTOR MESSAGE  
UNIT: N CYL- N DEVICE CODE (OCT)-N  
XXX STATUS = XXX (IF AVAILABLE)  
INTERPRETATION OF EACH FAILING BIT

DEVICE CODE	=	XXX	UNIT:	XXX	
DOC	DOA	DOB	DIC	DIA	DIB
XXX	XXX	XXX	XXX	XXX	XXX



## SECTION 5

### REMOVAL AND REPLACEMENT PROCEDURES

This section describes removal and replacement procedures for field replaceable units (FRUs) in the 6236/6237 disk drive subsystem. All procedures can be performed with the disk drive extended from its normal operating position in the equipment rack or installation cabinet. There are no field adjustments for the 6236/6237 disk drive subsystem.

#### WARNING

Prior to moving the disk drive from its normal operating position, be sure the Installation Cabinet Anti-tip bars are extended. Failure to do so may cause personal injury and/or equipment damage.

Repair of the 6236/6237 disk drive is limited to the removal and replacement of only the FRUs that are listed below:

- Controller PCB
- Coarse Air Filter
- Front Panel PCB
- Read/Write PCB
- Position Control PCB
- Control Logic PCB
- Power Amplifier PCB
- Spindle Control PCB
- Power Control PCB
- Power Supply Assembly
- Power Supply Stunt Plugs
- AC Circuit Breaker
- Power Supply Fuse (F1)
- Head Disk Assembly (HDA)
- Terminator
- AC Power Cord
- Latch Assembly\*
- Switch Assembly\*
- Power Package Fuse\*
- Power Package AC Power Cord\*
- Power Package \*

\* Model 6237 only

## WARNING

Observe the following safety precautions at all times. Failure to do so may cause personal injury and/or equipment damage.

- Use care while working with the power supply and power package because ac line voltages are present.
- Do not attempt to disassemble the Head Disk Assembly (HDA), it is not field repairable. Replace the entire HDA if it is found to be defective.
- Do not operate the disk drive over an extended period of time without the top cover installed. Error rate performance may be degraded without the top cover installed.

## FINAL ACCEPTANCE PROCEDURE

The following is the final acceptance procedure for verification of proper disk drive subsystem operation after FRU(s) replacement.

## NOTE

After a field replaceable unit (FRU) has been replaced, refer to the diagnostic troubleshooting procedure and/or diagnostic program that indicated the FRU failure, and verify the proper operation of the new FRU.

To verify proper subsystem operation load either the UDKV or UDKP RELI program (refer to Section 4). Run one error free pass of SA 501 and one error free pass of SA 502. (If a disk drive subsystem error condition exists, refer to Section 4 and troubleshoot the problem.)

To verify proper operation of the controller/PCB load the 6236 DIAG program (refer to Section 4). Specify controller only test, run one error free pass. Load the 6236 FUNC program, run one error free pass. (If a disk drive subsystem error condition exists, refer to Section 4 and troubleshoot the problem.) Load either the UDKV or UDKP RELI program (refer to Section 4). Run one error free pass of SA 501. (If a disk drive subsystem error condition exists, refer to Section 4 and troubleshoot the problem.)

## HANDLING ELECTROSTATIC DEVICES

The 6236/6237 disk drive subsystem printed circuit boards (PCBs) contain metal-oxide semiconductor (MOS) integrated circuits (ICs). These circuits require special handling procedures to prevent damage from static electricity. Service personnel must observe the following precautions when handling all PCBs in the 6236/6237 subsystem (including the controller PCB):

### CAUTION

The 6236/6237 disk drive PCB contains MOS IC chips. MOS chips can be damaged easily by a discharge of static electricity. Therefore, when handling MOS PCBs service personnel should do the following:

1. Before removing the PCB from its protective shipping bag and/or before handling it, touch a solid ground to eliminate static charge.
2. Handle the PCB as little as possible when it is out of its protective shipping bag.
3. Avoid carpeted floors especially in low humidity areas.

### 5.1 TOOLS AND EQUIPMENT

The following tools and test equipment are needed to perform maintenance, removal and replacement procedures on the 6236/6237 disk drive subsystem.

Table 5-1. Tools and Test Equipment

DESCRIPTION	DGC PART NO.
DGC Engineer Tool Kit	005-012583
Voltage Multimeter	128-000786
Oscilloscope	PHILIPS PM3212 or equivalent
Current ADES Media	

### 5.2 CONTROLLER PCB REMOVAL/REPLACEMENT

#### NOTE

For information on the Burst Multiplexor Channel Interface (BMCI) priority refer to the host CPU Product Summary and/or Installation and Packaging for Data General Corporation Peripherals (014-730).

#### Removal

1. Power-down the host CPU (refer to the host CPU Maintenance Service Guide or operator's manual for the proper procedure).
2. Power-down the disk drive (place the ON/OFF switch in the OFF position) (refer to section 2 for the power-down procedure). Set the ac circuit breaker in the OFF position (located in the rear of the disk drive).
3. Unplug the disk drive ac power cord.

4. Remove any panels from the CPU to expose the PCBs in the CPU.
5. Remove the two BMC ribbon cables and shorting plug from controller PCB.
6. Note the slot number and remove the 6236/6237 controller PCB (refer to Figure 5-1).

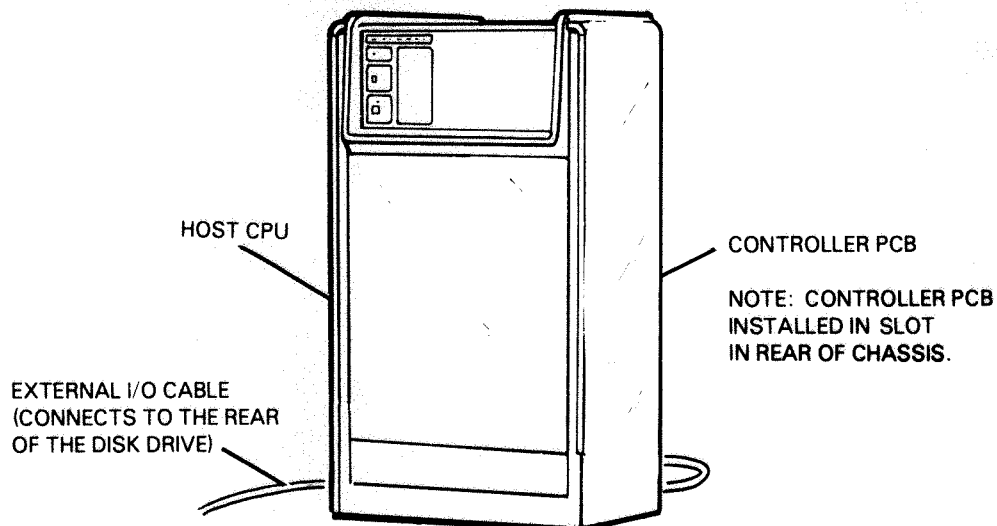

FS-07145

**Figure 5-1. Controller PCB**

7. Remove the new 6236/6237 controller PCB from its shipping container.
8. Set the device code jumpering to the same number as that of the controller PCB just removed. The primary device code is 24 and the secondary is 64. Insure remaining jumpers are also identical. Figure 5-2 shows the jumper locations on the controller PCB.

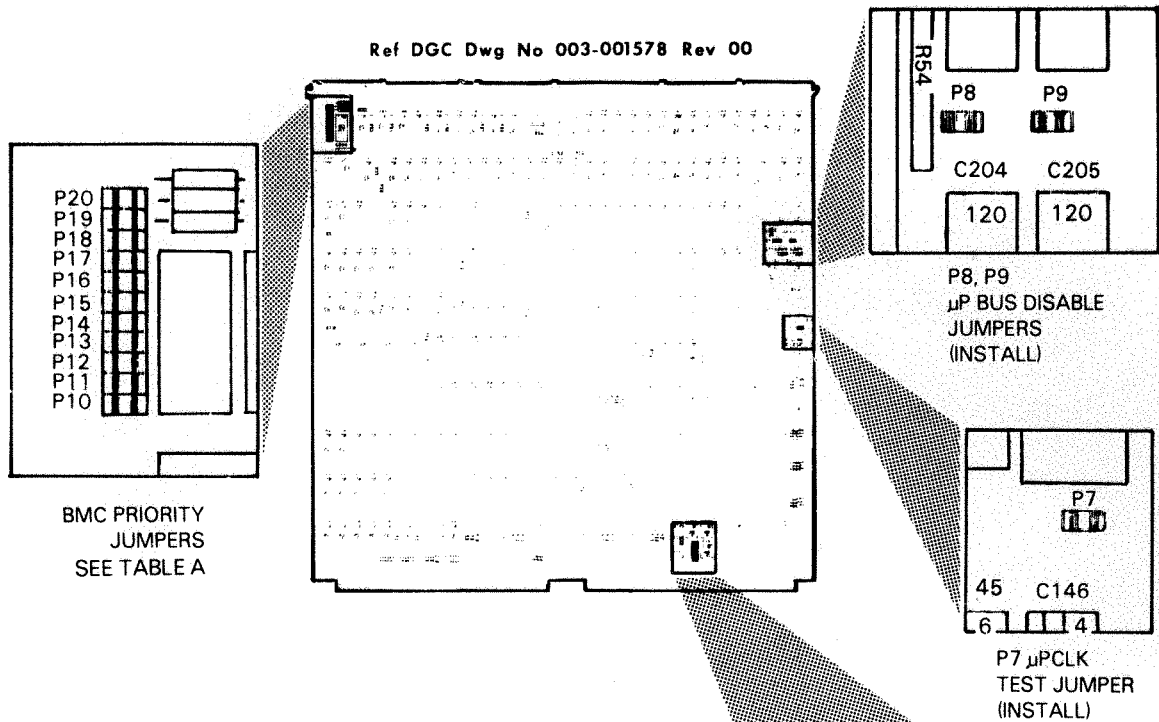
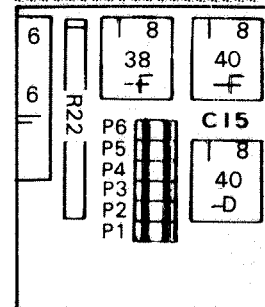

TABLE A BMCI BUS PRIORITY JUMPERS

PRIORITY	INSTALLED JUMPERS			
(HIGHEST)				
HSCR 7	P17	P18	P19	P20
HSCR 6	P16	P18	P19	
HSCR 5	P15	P18	P20	
HSCR 4	P14	P18		
HSCR 3	P13	P19	P20	
HSCR 2	P12	P19		
HSCR 1	P11	P20		
(LOWEST)				
HSCR 0	P10			



DEVICE CODE  
SELECT  
SEE TABLE B

TABLE B DEVICE CODE SELECT JUMPERS  
(JUMPER IN = 1, OUT = 0)

DEVICE CODE	MSB			LSB		
	P1	P2	P3	P4	P5	P6
PRIMARY = 24	0	1	0	1	0	0
SECONDARY = 64	1	1	0	1	0	0

OTHER DEVICE CODES ASSIGNED PER OCTAL ARRANGEMENT  
OF P1 → P6.

FS-07146

Figure 5-2. Controller PCB Device Code Jumpering

## Replacement

### **NOTE**

Carefully slide the controller PCB into the guides on each side of its slot in the computer chassis. The PCB should slide smoothly and not bind. The lock tabs provide the leverage needed to properly seat the circuit board connectors.

9. Install the new 6236/6237 controller PCB into its slot in the host CPU.
10. Install BMC cables and BMC terminator.
11. Replace any panels removed from the CPU.
12. Plug in the disk drive ac power cord.
13. Set the ac circuit breaker in the ON position.

### **5.3 FRONT PANEL REMOVAL/REPLACEMENT**

#### Removal

1. Depress the two tabs on the sides of the front panel assembly and remove the panel from the chassis (refer to Figure 5-3).

#### Replacement

2. Depress the tabs of the front panel assembly and install it on the front of the disk drive (Figure 5-3).

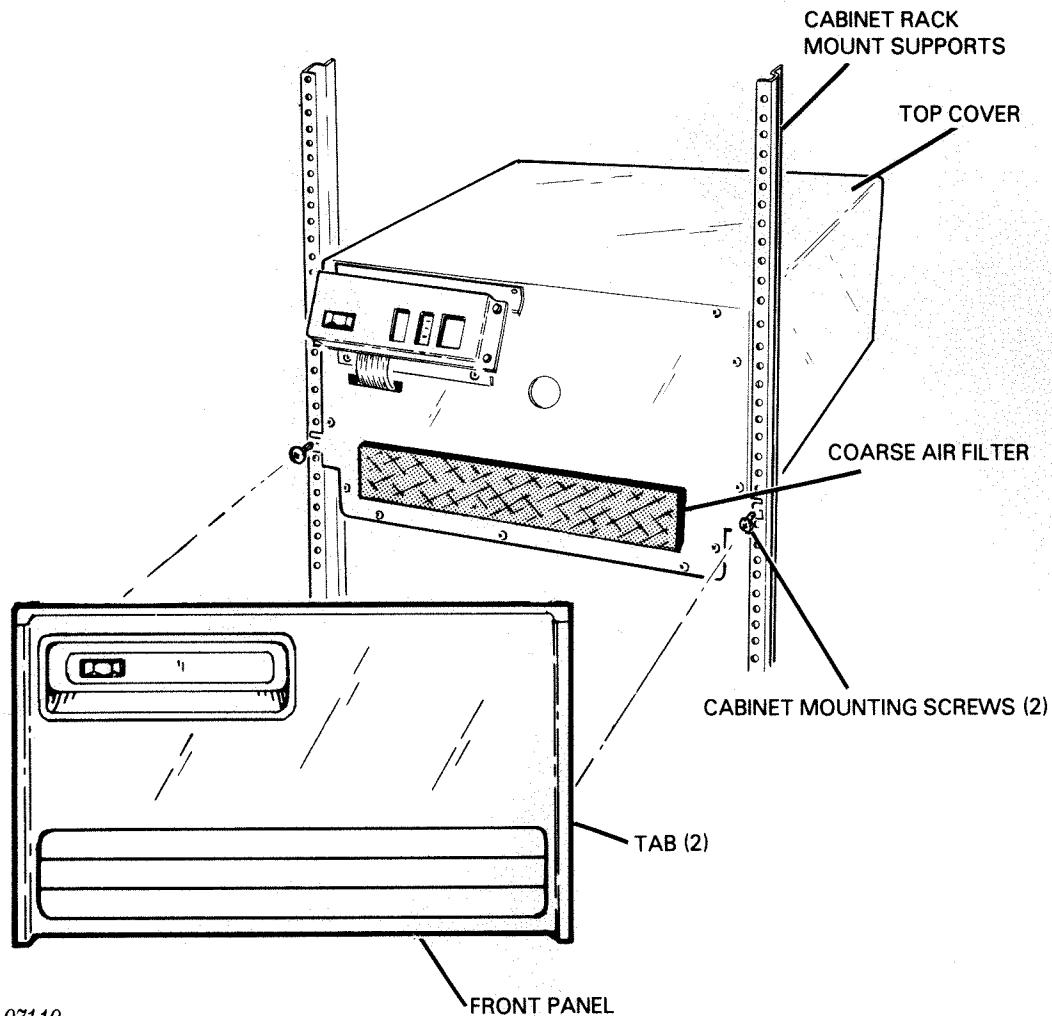

FS-07110

**Figure 5-3. Front Panel Removal and Replacement**

#### **5.4 OPENING AND CLOSING THE DRIVE**

##### **WARNING**

Prior to moving the disk drive from its normal operating position, be sure the Installation Cabinet Anti-tip bars are extended. Failure to do so may cause personal injury and/or equipment damage.

## Opening

1. Power-down the disk drive (place the ON/OFF switch in the OFF position). Refer to Section 2 for the power-down procedure. Set the ac circuit breaker in the OFF position (located in the rear of the disk drive).
2. Remove the front panel (refer to paragraph 5.3).
3. Remove the two mounting screws securing the front cover to the installation cabinet.
4. Slide the drive forward and out of the installation cabinet.

### **CAUTION**

When removing the top cover from the base weldment assembly be careful not to damage any wires or ribbon cables.

5. Remove the 18 screws securing the top cover to the base weldment assembly (refer to Figure 5-4). Carefully bend both sides of the top cover outward (in order to clear all PCBs, wires and cables on the PCB support assembly), lift the cover up and off of the base weldment assembly.

## Closing

6. Power-down the disk drive (place the ON/OFF switch in the OFF position). Refer to Section 2 for the power-down procedure.

### **CAUTION**

When installing the top cover on the base weldment assembly be careful not to damage any wires or ribbon cables. Before installing the top cover make sure all wires and ribbon cables are secured and not interfering with installation of the top cover. The edge of the top cover may damage wires and/or ribbon cables when it is installed.

7. Carefully bend both sides of the top cover outward (in order to clear all PCBs, wires and cables on the PCB support assembly), install the top cover on to the base weldment assembly.
8. Secure the top cover by tightening the 18 mounting screws.
9. Carefully slide the drive back into the installation cabinet until the front cover mounting brackets are flush with the installation cabinet rack mount supports.
10. Secure the drive in the installation cabinet by tightening the two mounting screws.



### CAUTION

Damage to the disk drive will occur if the disk drive is powered-up without the coarse air filter installed on the front cover.

11. Make sure the coarse air filter is present and positioned correctly on the front cover. Then install the front panel (refer to paragraph 5.3).

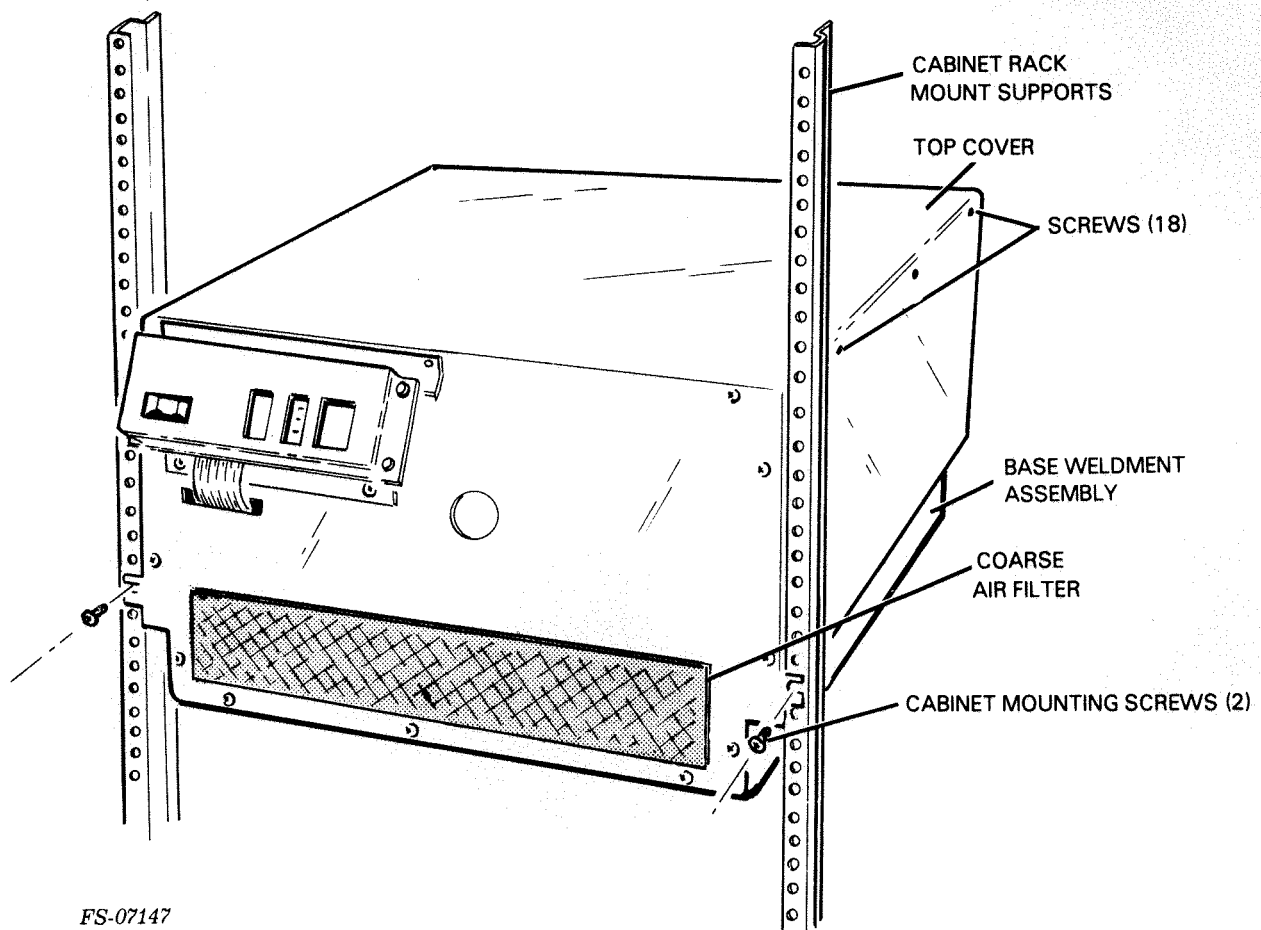

Figure 5-4. Top Cover

## 5.5 COARSE AIR FILTER REMOVAL/REPLACEMENT

### CAUTION

Damage to the disk drive will occur if the disk drive is powered-up without the coarse air filter installed on the front cover.

#### Removal

1. Remove the front panel (refer to paragraph 5.3).
2. Carefully peel the coarse air filter off of the VELCRO strip on the front cover, discard the filter (refer to Figure 5-5).

#### Replacement

3. Install the new filter on the VELCRO strip on the front cover. Position it correctly (refer to Figure 5-5).
4. Install the front panel (refer to paragraph 5.3).

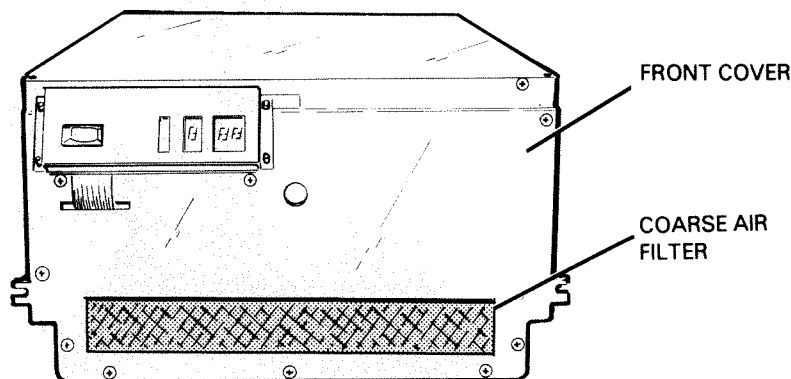

FS-07148

Figure 5-5. Coarse Air Filter

## 5.6 FRONT PANEL PCB REMOVAL/REPLACEMENT

### Removal

1. Power-down the disk drive (place the ON/OFF switch into the OFF position). Refer to Section 2 for the power-down procedure. Set the ac circuit breaker in the OFF position (located in the rear of the disk drive).
2. Remove the front panel (refer to paragraph 5.3).
3. Remove the four mounting nuts securing the display panel support to the display bracket bottom and display bracket top, remove the support (refer to Figure 5-6).
4. Press and release cable connector J1 (located on the back side of the front panel PCB). Remove the front panel PCB from the drive.

### Replacement

5. Set SW1 to SW4 on the new front panel PCB to the setting of the front panel PCB just removed (refer to Section 2 for information on SW1 to SW4).
6. Press the cable connector, install the front panel PCB on its four mounting studs and plug the connector into J1 (located on the rear of the front panel PCB).
7. Install the display panel support on its four mounting studs and secure it with the four mounting nuts removed in step number 3.
8. Close the drive (refer to paragraph 5.4).
9. Install the front panel (refer to paragraph 5.3).
10. Plug in the ac line cord, set the ac circuit breaker in the ON position.

Data General Corporation (DGC) has prepared this manual for use by DGC personnel and customers as a guide to the proper installation, operation, and maintenance of DGC equipment and software. The drawings and specifications contained herein are the property of DGC and shall neither be reproduced in whole or in part without DGC's prior written approval nor be implied to grant any license to make, use, or sell equipment manufactured in accordance herewith.

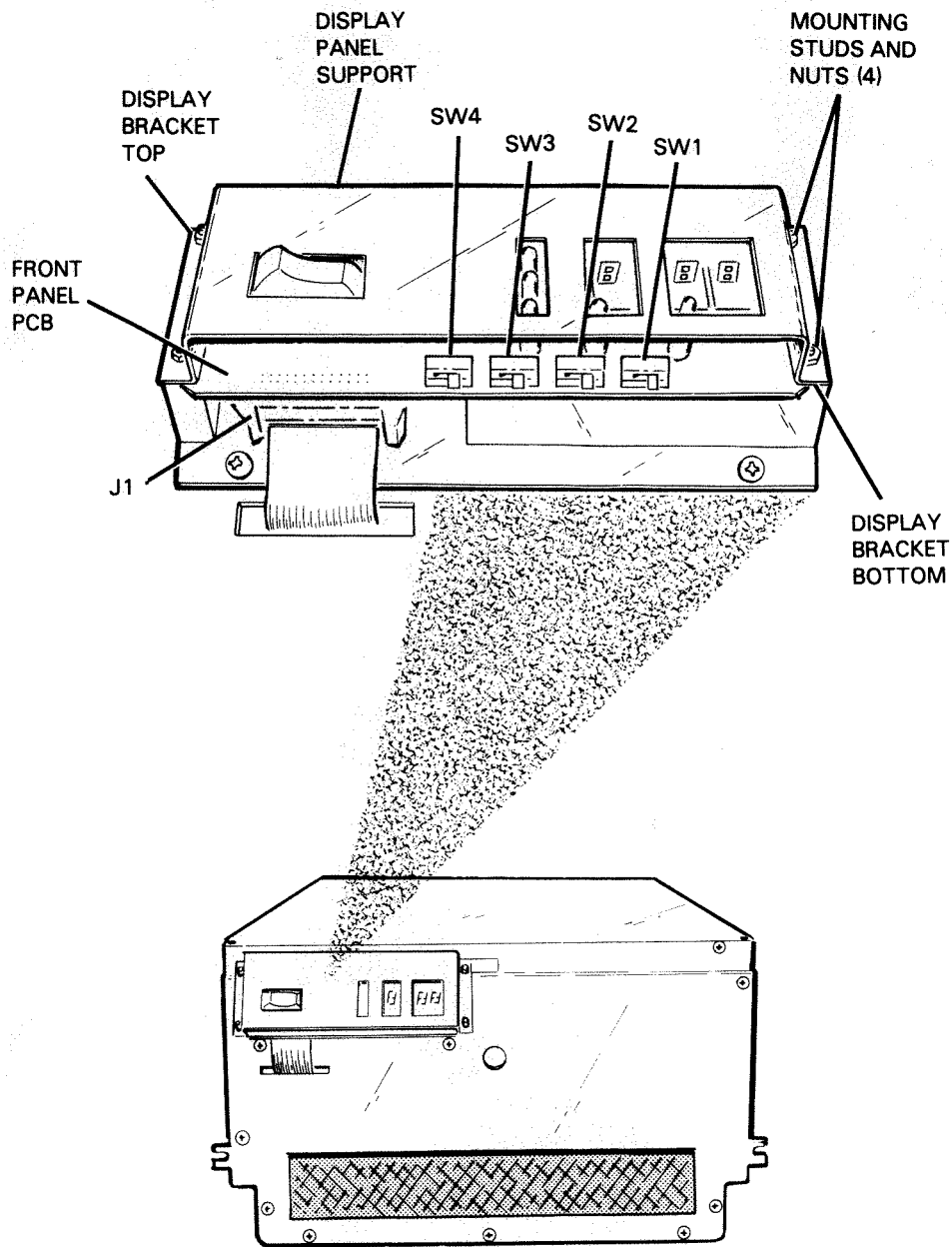

FS-07149

**Figure 5-6.** Front Panel PCB

## 5.7 READ/WRITE PCB REMOVAL/REPLACEMENT

### Removal

1. Power-down the disk drive (place the ON/OFF switch into the OFF position). Refer to Section 2 for the power-down procedure. Set the ac circuit breaker in the OFF position (located in the rear of the disk drive).
2. Remove the front panel (refer to paragraph 5.3).
3. Open up the drive (refer to paragraph 5.4).
4. Unplug connectors J1, J2 and J3 from the read/write PCB and make note of their position (refer to Figure 5-7).
5. Carefully unplug the five NYLATCH connectors that secure the read/write PCB to the PCB support assembly. Remove the read/write PCB from the drive.

### Replacement

6. Set SW1 (write protect) on the new read/write PCB to the same setting that the read/write PCB just removed was set to (refer to Section 2 for information on the write protect switch/SW1).
7. Install the new read/write PCB onto the PCB support assembly, making sure that it is positioned and seated correctly.
8. Plug in connectors J1, J2 and J3 to the read/write PCB.
9. Close the drive (refer to paragraph 5.4).
10. Install the front panel (refer to paragraph 5.3).
11. Plug in the ac line cord, set the ac circuit breaker in the ON position.

Data General Corporation (DGC) has prepared this manual for use by DGC personnel and customers as a guide to the proper installation, operation, and maintenance of DGC equipment and software. The drawings and specifications contained herein are the property of DGC and shall neither be reproduced in whole or in part without DGC's prior written approval nor be implied to grant any license to make, use, or sell equipment manufactured in accordance herewith.

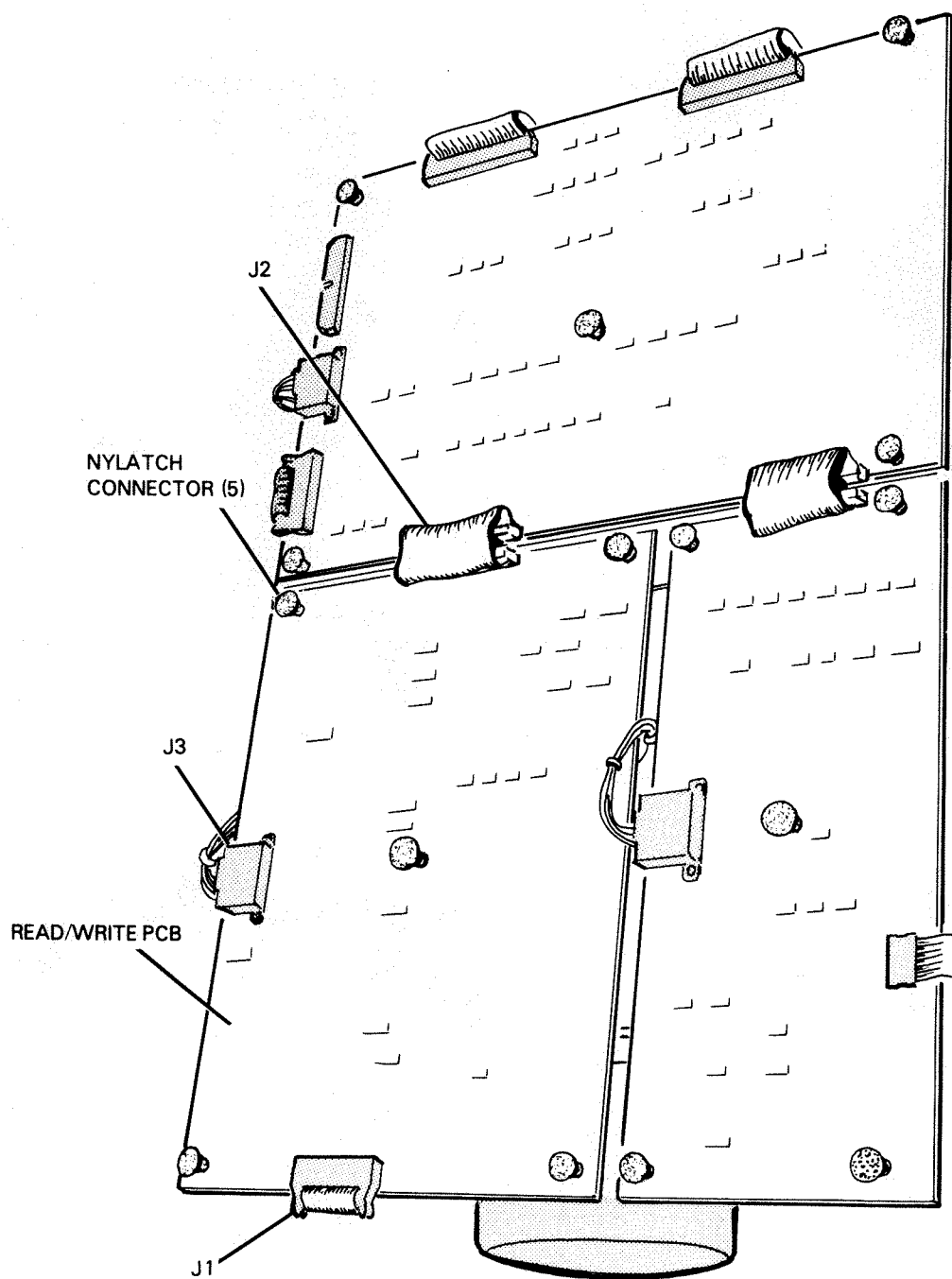

FS-07150

Figure 5-7. Read/Write PCB

## 5.8 POSITION CONTROL PCB REMOVAL/REPLACEMENT

### Removal

1. Power-down the disk drive (place the ON/OFF switch into the OFF position). Refer to Section 2 for the power-down procedure. Set the ac circuit breaker in the OFF position.
2. Remove the front panel (refer to paragraph 5.3).
3. Open up the drive (refer to paragraph 5.4).
4. Unplug connectors J1, J2 and J3 and make note of their position (refer to Figure 5-8).
5. Carefully unplug the five NYLATCH connectors that secure the position control PCB to the PCB support assembly, carefully remove the PCB from the drive.

### Replacement

6. Install the new position control PCB onto the PCB support assembly making sure it is positioned and seated correctly.
7. Plug in connectors J1, J2 and J3 to the new position control PCB.
8. Close the drive (refer to paragraph 5.4).
9. Install the front panel (refer to paragraph 5.3).
10. Plug in the ac line cord, set the ac circuit breaker in the ON position.

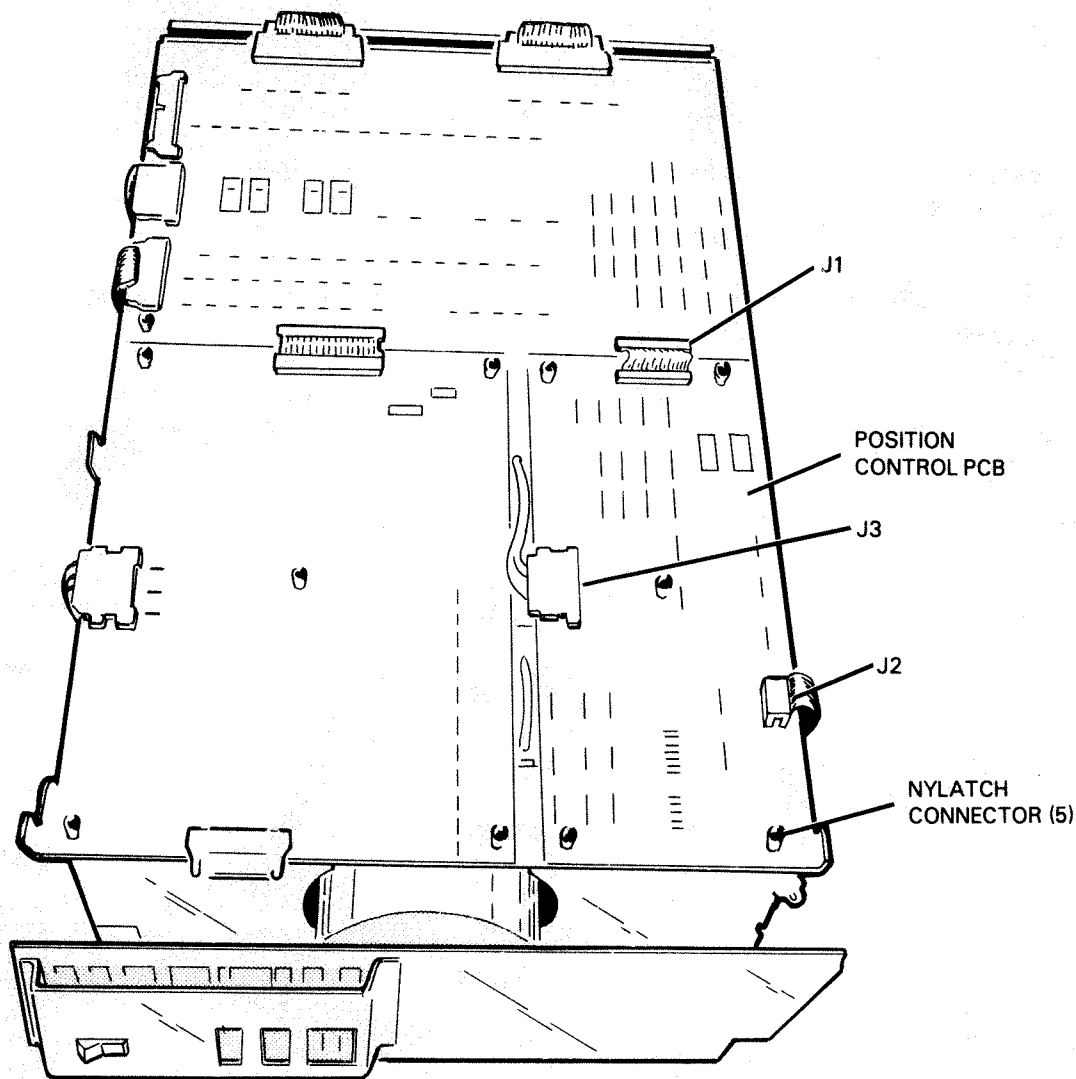

FS-07151

Figure 5-8. Position Control PCB



## 5.9 CONTROL LOGIC PCB REMOVAL/REPLACEMENT

### Removal

1. Power-down the disk drive (place the ON/OFF switch into the OFF position). Refer to Section 2 for the power-down procedure. Set the ac circuit breaker in the OFF position.
2. Remove the front panel (refer to paragraph 5.3).
3. Open up the drive (refer to paragraph 5.4).
4. Unplug connectors J1 to J7 from the control logic PCB and make note of their position (refer to Figure 5-9).
5. Carefully unplug the five NYLATCH connectors that secure the control logic PCB to the PCB support assembly. Remove the PCB from the drive.

### Replacement

6. Install the new control logic PCB onto the PCB support assembly making sure it is positioned and seated correctly.
7. Plug in connectors J1 to J7 to the control logic PCB.
8. Close the drive (refer to paragraph 5.4).
9. Install the front panel (refer to paragraph 5.3).
10. Plug in the ac line cord, set the ac circuit breaker in the ON position.

Data General Corporation (DGC) has prepared this manual for use by DGC personnel and customers as a guide to the proper installation, operation, and maintenance of DGC equipment and software. The drawings and specifications contained herein are the property of DGC and shall neither be reproduced in whole or in part without DGC's prior written approval nor be implied to grant any license to make, use, or sell equipment manufactured in accordance herewith.

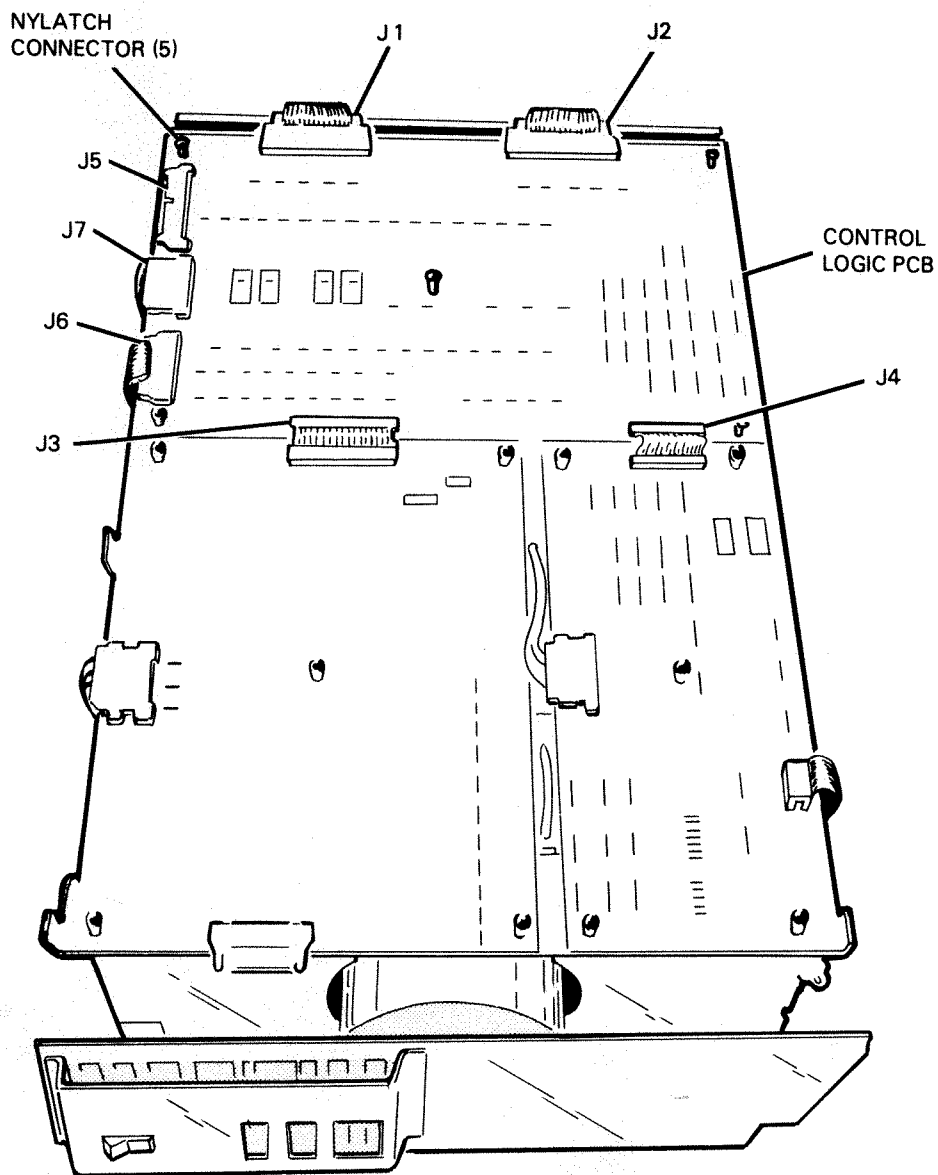

FS-07152

Figure 5-9. Control Logic PCB

## 5.10 POWER AMPLIFIER PCB REMOVAL/REPLACEMENT

### Removal

1. Power-down the disk drive (place the ON/OFF switch into the OFF position). Set the ac circuit breaker in the OFF position.
2. Remove the front panel (refer to paragraph 5.3).
3. Open up the drive (refer to paragraph 5.4).
4. Unplug connectors J1 to J5 from the power amplifier PCB and make note of their position (refer to Figure 5-10).
5. Carefully unplug the four NYLATCH connectors that secure the power amplifier PCB to the PCB support assembly, remove the PCB from the drive.

### Replacement

6. Set the disable switch on the new power amplifier PCB to the setting that the PCB just removed was set to (refer to Section 2 for information on the disable switch).
7. Install the power amplifier PCB onto the PCB support assembly making sure that it is positioned and seated correctly.
8. Plug in connectors J1 to J5 to the power amplifier PCB.
9. Close the drive (refer to paragraph 5.4).
10. Install the front panel (refer to paragraph 5.3).
11. Plug in the ac line cord, set the ac circuit breaker in the ON position.

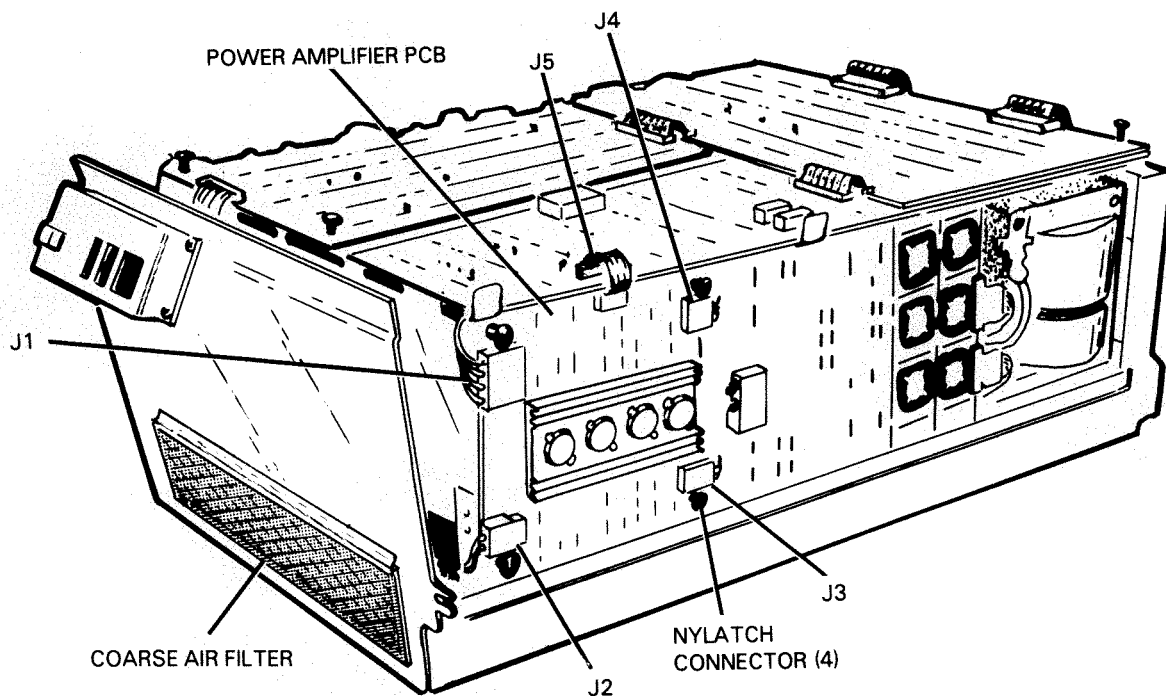

FS-07153

Figure 5-10. Power Amplifier PCB

## 5.11 SPINDLE CONTROL PCB REMOVAL/REPLACEMENT

### Removal

1. Power-down the disk drive (place the ON/OFF switch into the OFF position). Refer to Section 2 for the power-down procedure. Set the ac circuit breaker in the OFF position.
2. Remove the front panel (refer to paragraph 5.6).
3. Open up the drive (refer to paragraph 5.4).
4. Unplug connectors J1 to J5 from the spindle control PCB and make note of their position (refer to Figure 5-11).
5. Carefully unplug the four NYLATCH connectors that secure the spindle control PCB to the PCB support assembly, remove the PCB from the drive.

### Replacement

6. Install the new spindle control PCB onto the PCB support assembly making sure that it is positioned and seated correctly.
7. Plug in connectors J1 to J5 on the PCB.
8. Close the drive (refer to paragraph 5.4).
9. Install the front panel (refer to paragraph 5.3).

10. Plug in the ac line cord then set the ac circuit breaker in the ON position.

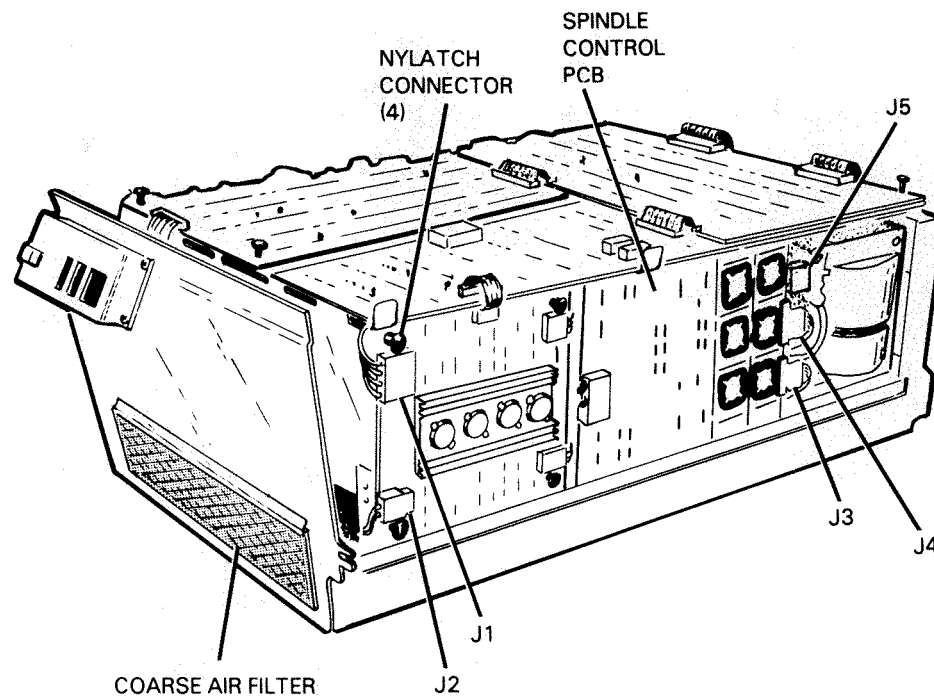

FS-07154

Figure 5-11. Spindle Control PCB

## 5.12 POWER CONTROL PCB REMOVAL/REPLACEMENT

### Removal

1. Power-down the disk drive (place the ON/OFF switch into the OFF position). Refer to Section 2 for the power-down procedure. Set the ac circuit breaker in the OFF position.
2. Remove the front panel (refer to paragraph 5.3).
3. Open up the drive (refer to paragraph 5.4).
4. Unplug connectors J1 to J6 from the power control PCB and make note of their position (refer to Figure 5-12).
5. Carefully unplug the six NYLATCH connectors that secure the power control PCB to the PCB support assembly.
6. Carefully move the PCB away from the PCB support frame (approximately 3 inches) to gain access to the two connectors (J7 and J8) attached to the rear side of the PCB. Unplug the two connectors and make note of their position.
7. Carefully remove the PCB from the drive.

## Replacement:

8. Plug connectors J7 and J8 into the new power control PCB.
9. Install the new power control PCB onto the PCB support assembly making sure it is positioned and seated correctly.
10. Plug in connectors J1 to J6 on the new power control PCB.
11. Close the drive (refer to paragraph 5.4).
12. Install the front panel (refer to paragraph 5.3).
13. Plug in the ac line cord, set the ac circuit breaker in the ON position.

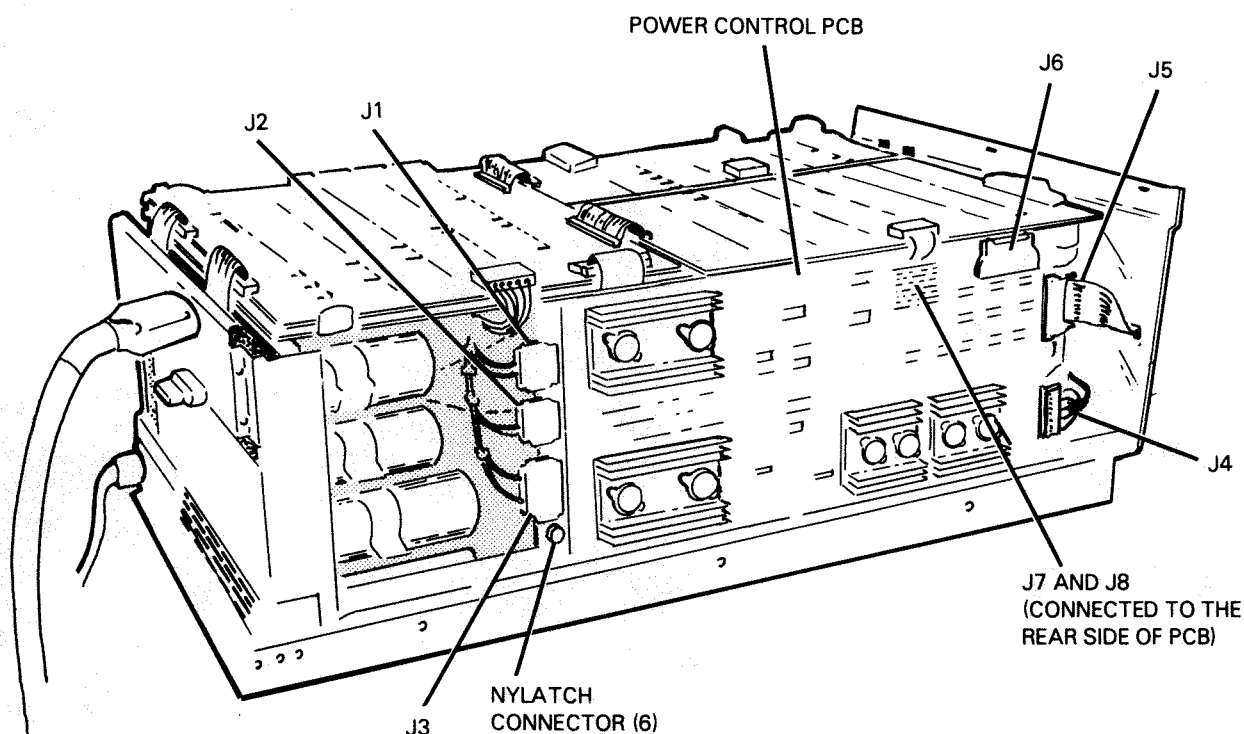

FS-07155

Figure 5-12. Power Control PCB

## 5.13 POWER SUPPLY ASSEMBLY REMOVAL/REPLACEMENT

### Removal

#### WARNING

After powering down the drive, high voltages are still present. Wait at least five minutes for the capacitor to discharge to a safe level (50V). After five minutes residual voltages may still exist on the power supply PCB.

#### NOTE

Rear access to the disk drive is required for the removal and replacement of the power supply assembly.

1. Power-down the disk drive (place the ON/OFF switch into the OFF position). Refer to Section 2 for the power-down procedure. Set the ac circuit breaker in the OFF position.
2. Unplug external I/O cables, terminator, and ac power cord from the rear of the drive.
3. Remove the front panel (refer to paragraph 5.3).
4. Open up the drive (refer to paragraph 5.4).
5. Remove the four screws securing the rear cover to the base weldment assembly, remove the cover (refer to Figure 5-13).
6. Disconnect connector J3 on the power amplifier PCB (refer to Figure 5-14).
7. Disconnect connectors J1 to J5 on the spindle control PCB (refer to Figure 5-14).
8. Carefully unplug the four NYLATCH connectors that secure the spindle control PCB to the PCB support assembly, remove the PCB from the drive.
9. Disconnect connectors J1, J2 and J3 on the power control PCB (refer to Figure 5-15).
10. Disconnect connectors J1 and J2 on the position control PCB (refer to Figure 5-15).
11. Remove the six nuts securing the PCB support assembly to the base weldment assembly.
12. Remove the four screws securing the power supply to the base weldment assembly.
13. Remove power supply ground strap (refer to Figure 5-15).

14. Lift up the PCB support assembly (from the rear support) approximately 1.5 inches off of the base weldment assembly.

#### CAUTION

When removing the power supply from the base weldment assembly be careful not to damage any wires, ribbon cables or PCBs on the PCB support assembly.

15. Carefully remove the power supply assembly from the drive.
16. Remove the four screws that secure the ac circuit breaker to the power supply, then remove the ac circuit breaker from the power supply. Refer to paragraph 5.15 for the ac circuit breaker removal and replacement procedure.
17. Install the original ac circuit breaker in the new power supply. Secure it with the four mounting screws, set the ac circuit breaker in the OFF position.
18. Remove the clear plastic protective cover from the power supply that was just removed (refer to Figure 5-13). Remove the three power supply stunt plugs from the power supply that was just removed (make note of their position). Refer to paragraph 5.14 for the power supply stunt plugs removal and replacement procedure.
19. Remove the clear plastic protective cover from the new power supply.
20. Install the three power supply stunt plugs on the new power supply. The new power supply must be jumpered to the same voltage configuration that the power supply just removed was jumpered to. Refer to Section 6 for power supply jumper configuration information. Install the clear plastic protective cover on the new power supply.

#### Replacement

#### CAUTION

When installing the new power supply on the base weldment assembly be careful not to damage any wires, ribbon cables or PCBs on the PCB support assembly.

21. Lift up the PCB support assembly (from the rear) approximately 1.5 inches off the base weldment assembly. Install the new power supply on the base weldment assembly.
22. Replace and tighten the four screws that secure the power supply to the base weldment assembly.
23. Install power supply ground strap.
24. Replace and tighten the six nuts that secure the PCB support assembly to the base weldment assembly.



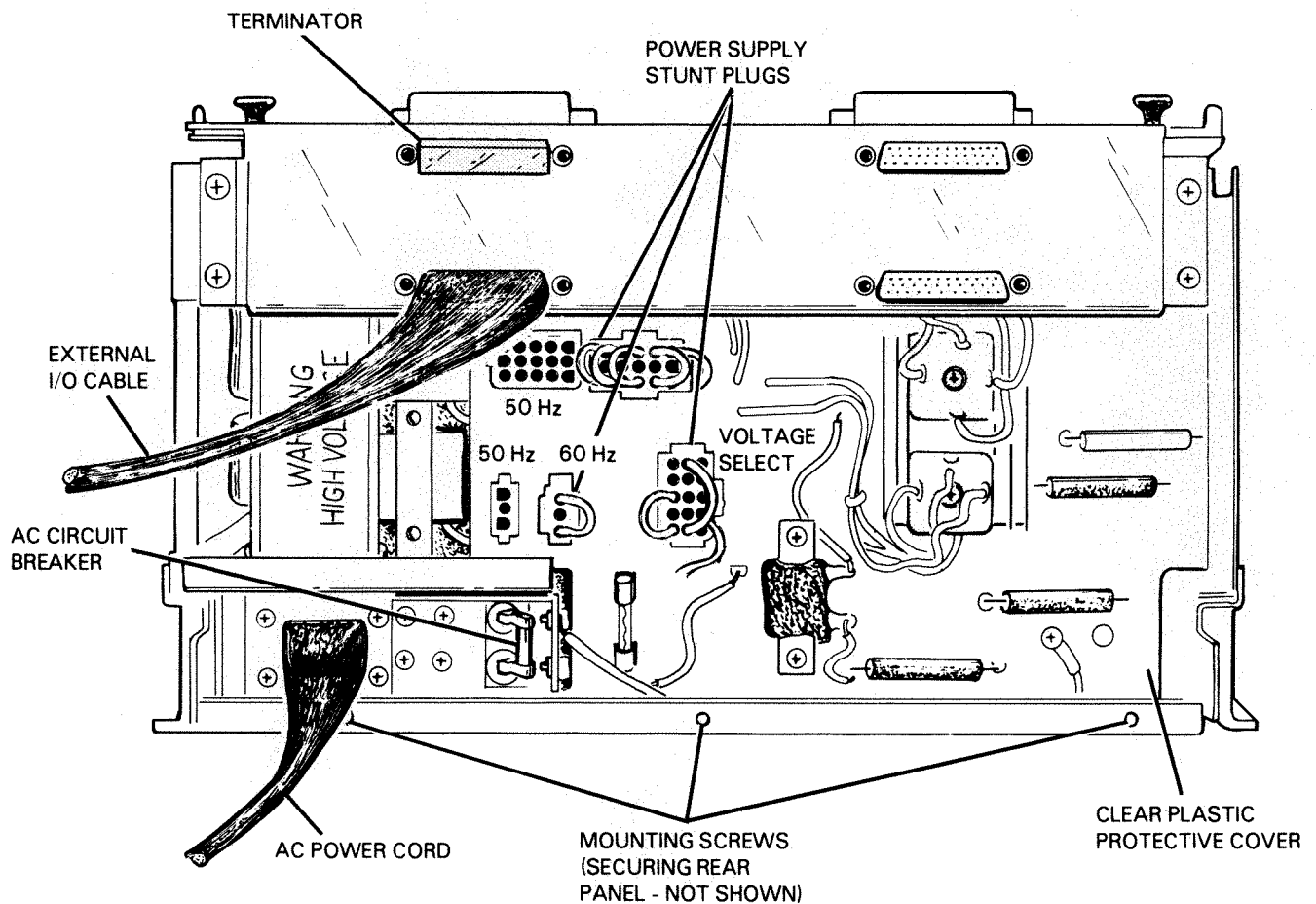

FS-07156

Figure 5-13. Power Supply (rear view)

25. Plug in connectors J1 and J2 on the position control PCB.
26. Plug in connectors J1, J2 and J3 on the power control PCB.
27. Plug in connector J3 on the power amplifier PCB.

Data General Corporation (DGC) has prepared this manual for use by DGC personnel and customers as a guide to the proper installation, operation, and maintenance of DGC equipment and software. The drawings and specifications contained herein are the property of DGC and shall neither be reproduced in whole or in part without DGC's prior written approval nor be implied to grant any license to make, use, or sell equipment manufactured in accordance herewith.

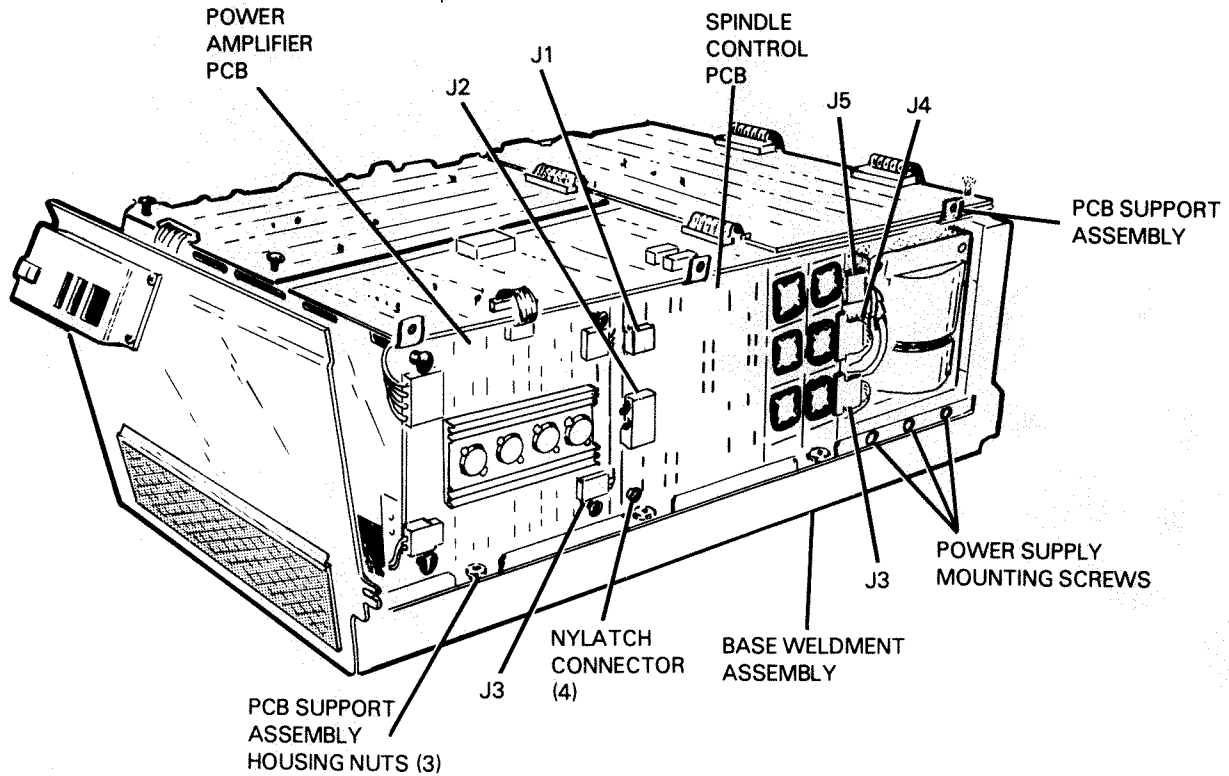

FS-07157

Figure 5-14. Power Supply (side view)

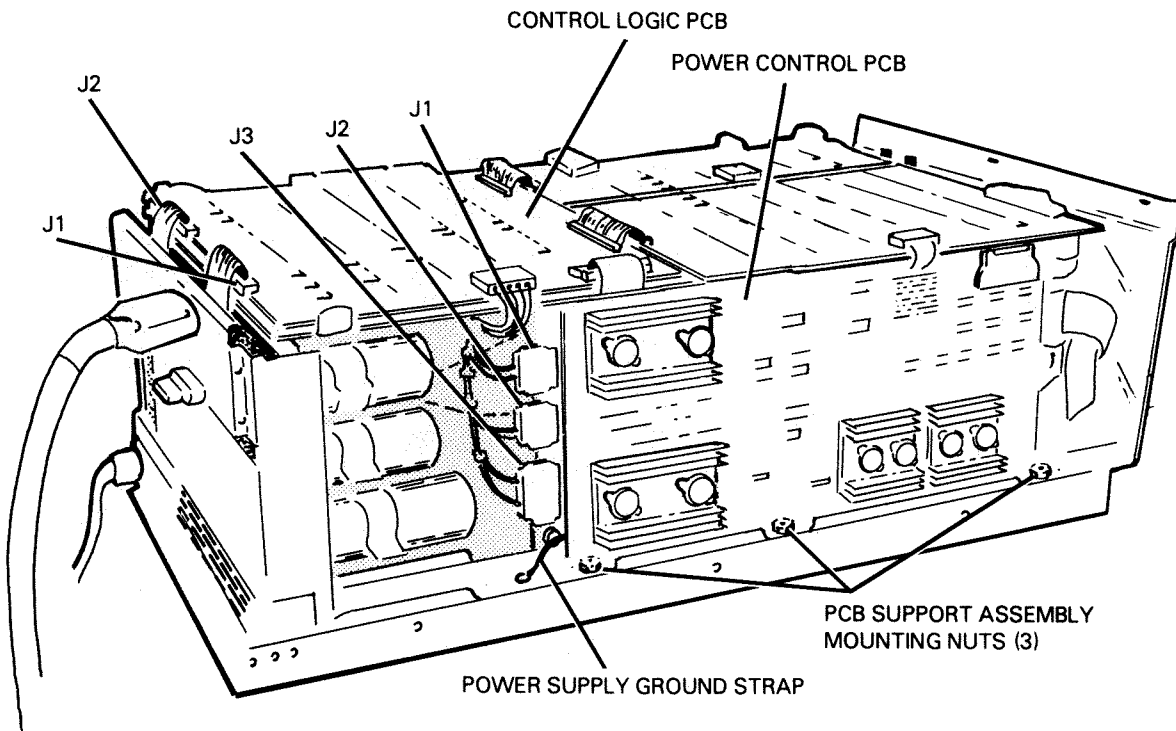

FS-07158

Figure 5-15. Power Control PCB and Control Logic PCB

28. Install the spindle control PCB onto the PCB support assembly making sure that it is positioned and seated correctly.
29. Plug in connectors J1 to J5 on the spindle control PCB.
30. Install the rear panel and secure it with its four mounting screws.
31. Attach the ac power cord, external I/O cables and terminator to the rear of the drive.
32. Close the drive (refer to paragraph 5.4).
33. Install the front panel (refer to paragraph 5.3).
34. Plug in the ac power cord, set the ac circuit breaker in the ON position.

#### 5.14 POWER SUPPLY STUNT PLUGS REMOVAL/REPLACEMENT

##### WARNING

After powering down the drive, high voltages are still present. Wait at least five minutes for the capacitor to discharge to a safe level (50V). After five minutes residual voltages may still exist on the power supply PCB.

##### Removal

1. Power-down the disk drive (place the ON/OFF switch in the OFF position). Refer to Section 2 for the power-down procedure. Set the ac circuit breaker in the OFF position (located in the rear of the drive).
2. Unplug external I/O cables, terminator, and ac power cord from the rear of the drive.
3. Remove the four screws securing the rear cover to the base weldment assembly (refer to Figure 5-16). Remove the rear cover.
4. Remove the clear plastic protective cover on the rear of the power supply (refer to Figure 5-16).
5. Disconnect the power supply voltage stunt plugs from the rear of the power supply (refer to Figure 5-16).

##### Replacement

6. Install the power supply stunt plugs on the rear of the power supply (refer to Figure 5-16). Refer to Section 6 for information on power supply voltage jumper configuration.
7. Install the clear plastic protect cover on the rear of the power supply.

8. Install the rear cover to the base weldment assembly.
9. Attach the ac power cord, external I/O cable and terminator to the rear of the drive.
10. Plug in the ac power cord, set the ac circuit breaker in the ON position.

## 5.15 AC CIRCUIT BREAKER REMOVAL/REPLACEMENT

### WARNING

After powering down the drive, high voltages are still present. Wait at least five minutes for the capacitor to discharge to a safe level (50V). After five minutes residual voltages may still exist on the power supply PCB.

#### Removal

1. Power down the disk drive (place the ON/OFF switch in the OFF position). Refer to Section 2 for the power-down procedure. Set the ac circuit breaker in the OFF position (located in the rear of the drive).
2. Unplug external I/O cables, terminator, and ac power cord from the rear of the drive.
3. Remove the four screws securing the rear cover to the base weldment assembly (refer to Figure 5-16). Remove the rear cover.
4. Remove the clear plastic protective cover on the rear of the power supply (refer to Figure 5-16).
5. Remove the four screws securing the ac circuit breaker to the power supply (refer to Figure 5-16). Remove the ac circuit breaker from the power supply and unplug the two wires connected to the circuit breaker.

#### Replacement

6. Install the new ac circuit breaker in the power supply, plug in the wires, and secure it with the four mounting screws.
7. Install the clear plastic protect cover on the rear of the power supply.
8. Install the rear cover to the base weldment assembly.
9. Attach the ac power cord, external I/O cable and terminator to the rear of the drive.
10. Plug in the ac power cord, set the ac circuit breaker in the ON position.

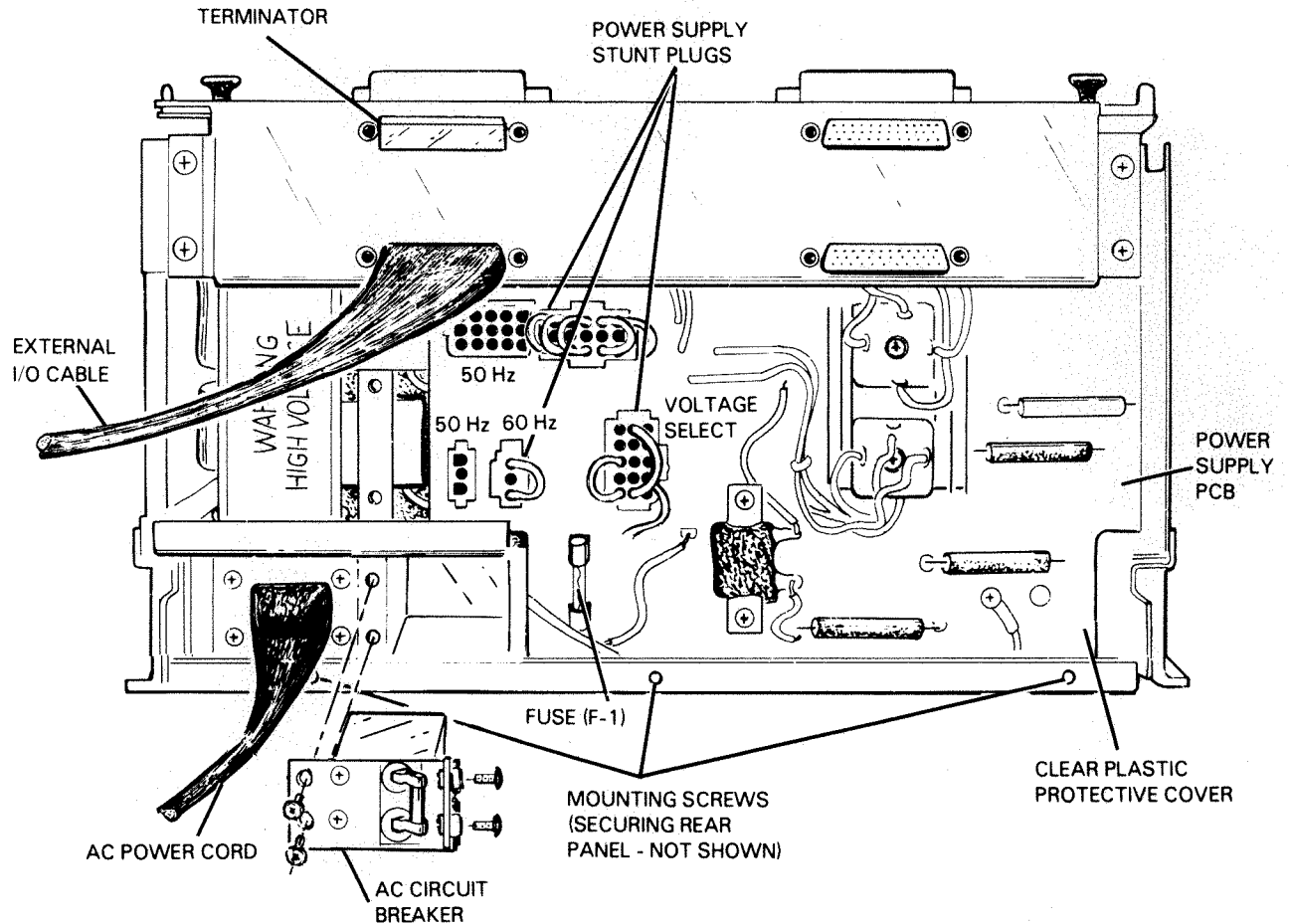

FS-07159

**Figure 5-16. AC Circuit Breaker**

### **5.16 POWER SUPPLY FUSE (F1) REMOVAL/REPLACEMENT**

#### Removal

1. Power-down the disk drive (place the ON/OFF switch in the OFF position). Set the ac circuit breaker in the OFF position (located in the rear of the drive).
2. Unplug the external I/O cables, terminator, and ac power cord from the rear of the drive.

3. Remove the four screws securing the rear panel to the base weldment assembly (refer to Figure 5-16). Remove the rear cover.
4. Remove the clear plastic protective cover on the rear of the power supply (refer to Figure 5-16).
5. Remove the fuse from the power supply PCB on the rear of the power supply (refer to Figure 5-16).

#### Replacement

6. Install the new fuse on the power supply PCB.
7. Install the clear plastic protect cover on the rear of the power supply.
8. Install the rear cover to the base weldment assembly.
9. Attach the ac power cord, external I/O cable and terminator to the rear of the drive.
10. Plug in the ac power cord, set the ac circuit breaker in the ON position.

### 5.17 HEAD DISK ASSEMBLY (HDA) REMOVAL/REPLACEMENT

#### Removal

##### **WARNING**

After powering down the drive, high voltages are still present. Wait at least five minutes for the capacitor to discharge to a safe level (50V). After five minutes residual voltages may still exist on the power supply PCB.

##### **CAUTION**

Do not attempt to disassemble the Head Disk Assembly (HDA), it is not field repairable. Replace the entire HDA if it is found to be defective.

##### **CAUTION**

The Carriage Locking Rod must be installed in the HDA before the HDA is removed from the drive. If the Carriage Locking Rod is not installed, damage will occur to the HDA when the HDA is moved from its mounted position. Refer to Section 6 for information on the installation of the Carriage Locking Rod.

1. Power-down the disk drive (place the ON/OFF switch into the OFF position). Refer to Section 2 for the power-down procedure. Set the circuit breaker in the off position, unplug the ac line cord.
2. Remove the front panel (refer to paragraph 5.3).
3. Open up the drive (refer to paragraph 5.4).
4. Disconnect connector J5 on the power control PCB (refer to Figure 5-17).
5. Remove the three screws securing the front cover to the base weldment assembly, remove the front cover.
6. Remove the L.H. and R.H. plenums from the PCB support assembly (refer to Figure 5-18).
7. Disconnect connectors J2 and J3 on the power amplifier PCB (refer to Figure 5-19).
8. Disconnect connectors J2, J3, J4 and J5 on the spindle control PCB (refer to Figure 5-19).
9. Disconnect connector J1 on the read/write PCB (refer to Figure 5-18).
10. Disconnect connectors J1 and J2 on the control logic PCB (refer to Figure 5-18).
11. Disconnect connectors J1, J2 and J3 on the power control PCB (refer to Figure 5-17).
12. Remove the six nuts securing the PCB support assembly to the base weldment assembly.

#### CAUTION

When removing the PCB support assembly be careful not to damage any wires or ribbon cables.

13. Remove the PCB support assembly from the base weldment assembly (with the PCBs secured to the PCB support assembly).
14. Remove the four mounting nuts securing the HDA to the air duct and base weldment assembly (refer to Figure 5-20).
15. Remove the bolt securing the HDA to the base weldment assembly (gain access from the front side of the disk drive, refer to Figure 5-20).

#### WARNING

The HDA weighs 70 lbs., use caution when removing the HDA off of the base weldment assembly to prevent physical injury.

**CAUTION**

Do not lift the HDA by pulling up on the linear motor. The pulling force on the linear motor will damage it.

**CAUTION**

When removing the HDA be careful not to damage the HDA air support bracket, any wires or cables. Do not dent, bend or damage the blower. It must be balanced.

16. Carefully lift the HDA off of the base weldment assembly (refer to Figure 5-20). Place the HDA in a safe, clean area.
17. Disconnect the linear motor and read/write cables from the HDA that was just removed (refer to Figure 5-21).
18. Connect the linear motor and read/write cables to the new HDA.

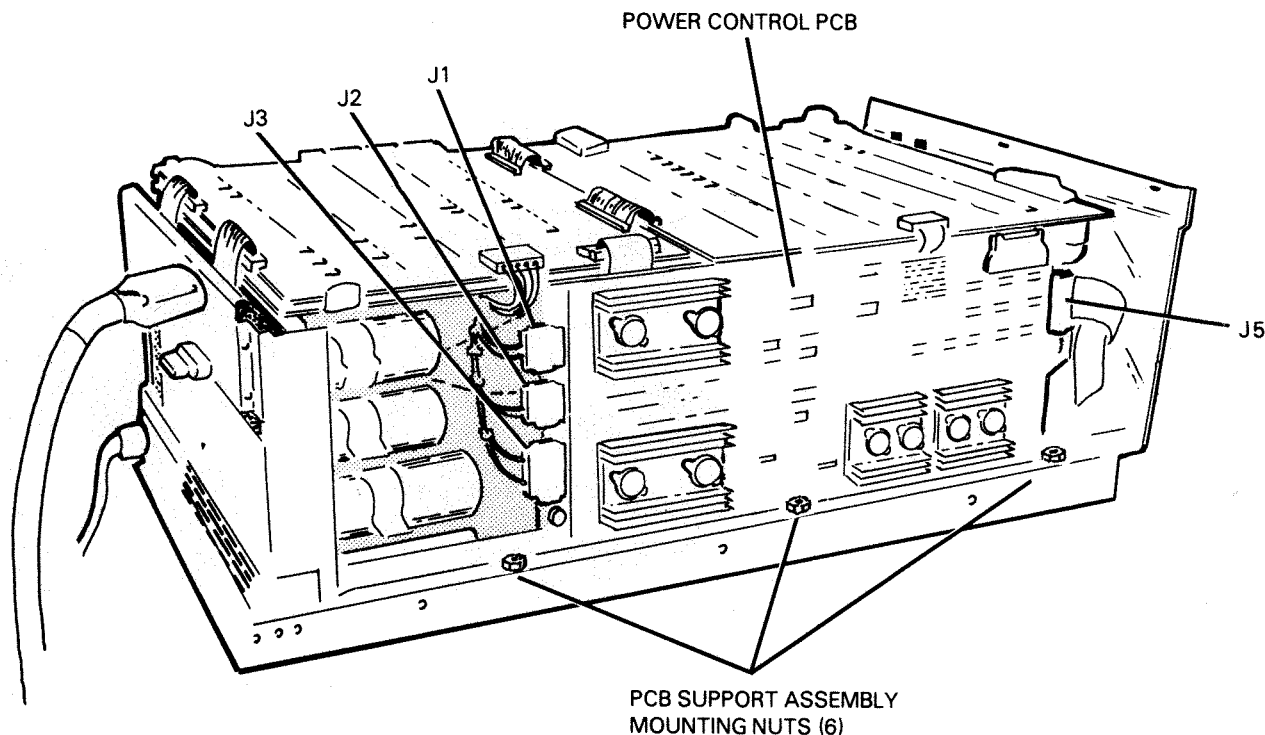

FS-07160

Figure 5-17. Power Control PCB



Data General Corporation (DGC) has prepared this manual for use by DGC personnel and customers as a guide to the proper installation, operation, and maintenance of DGC equipment and software. The drawings and specifications contained herein are the property of DGC and shall neither be reproduced in whole or in part without DGC's prior written approval nor be implied to grant any license to make, use, or sell equipment manufactured in accordance herewith.

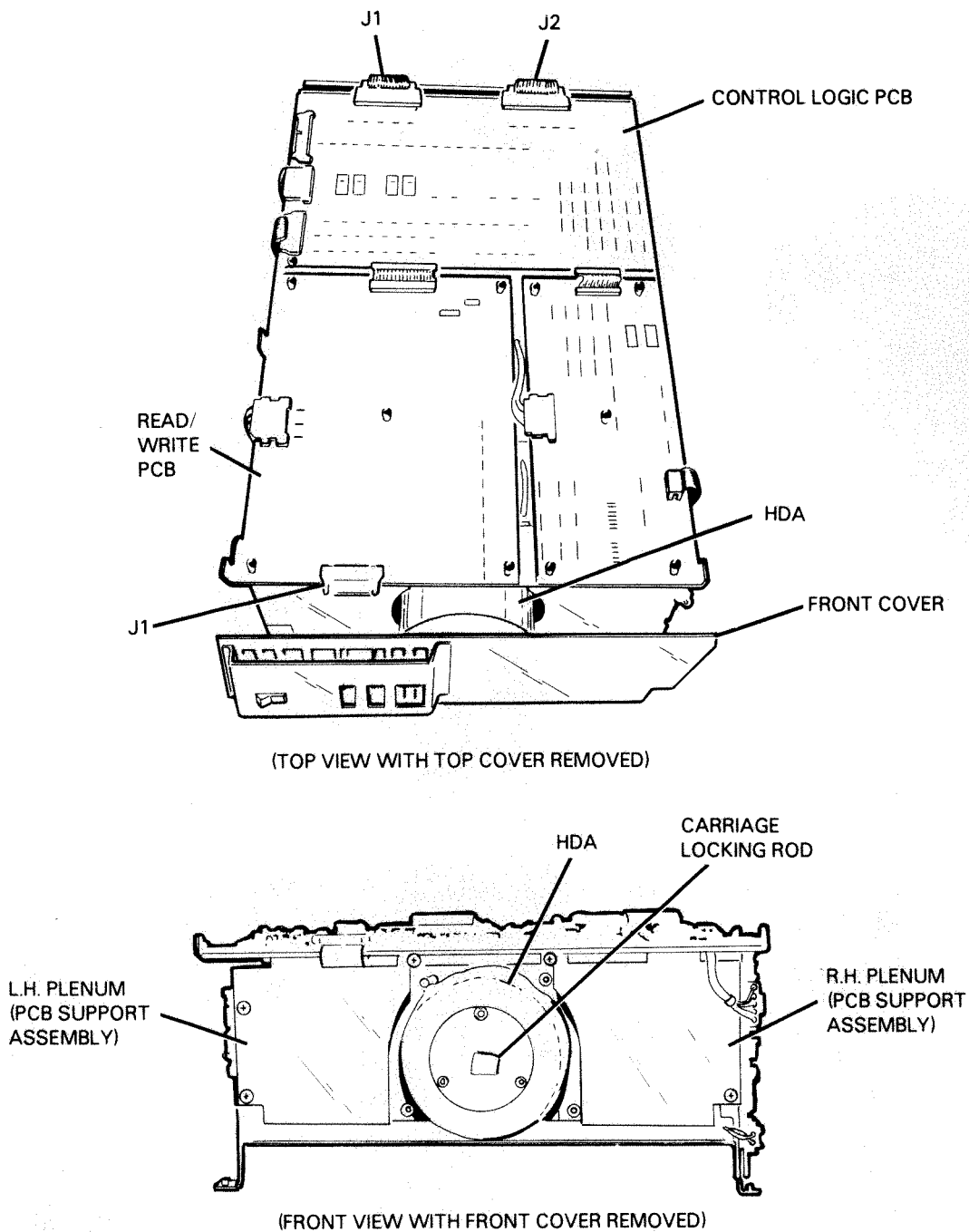

FS-07161

Figure 5-18. Drive Assembly (Front and Top Views)

Data General Corporation (DGC) has prepared this manual for use by DGC personnel and customers as a guide to the proper installation, operation, and maintenance of DGC equipment and software. The drawings and specifications contained herein are the property of DGC and shall neither be reproduced in whole or in part without DGC's prior written approval nor be implied to grant any license to make, use, or sell equipment manufactured in accordance herewith.

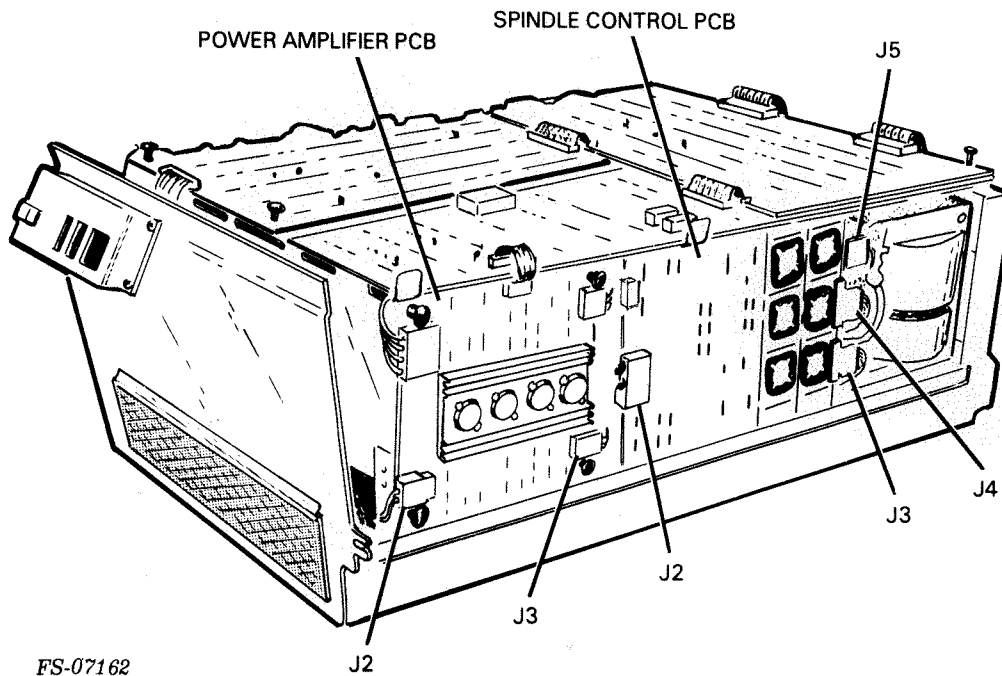

FS-07162

Figure 5-19. Spindle Control PCB and Power Control PCB

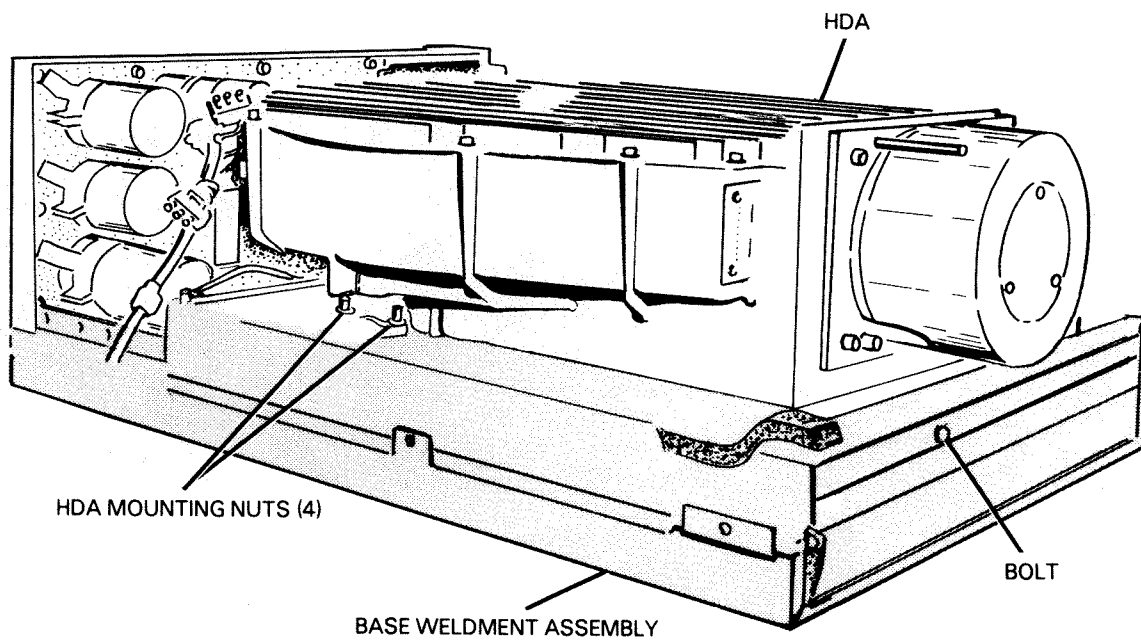

FS-07163

Figure 5-20. HDA (with PCB Support Assembly removed)

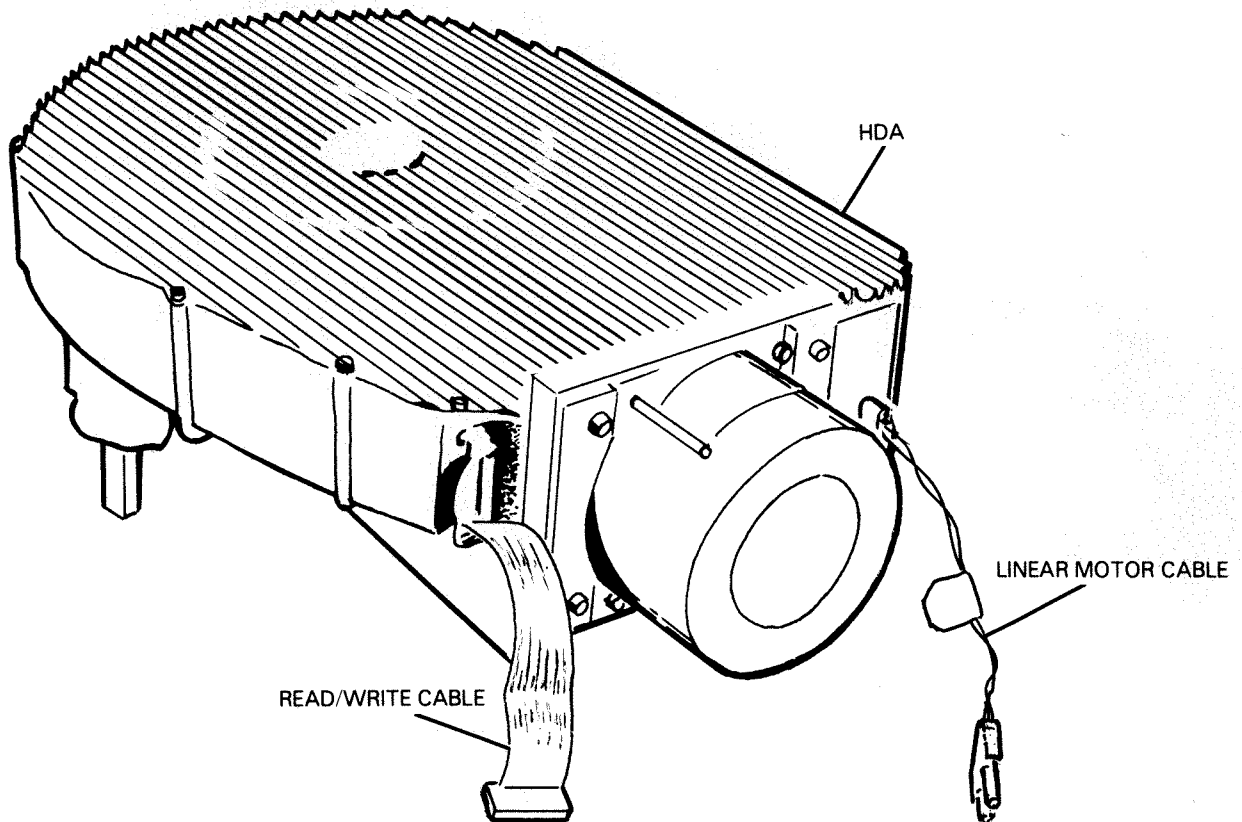

FS-07164

Figure 5-21. HDA (Front View)

### Replacement

19. Install the new HDA on the four mounting studs on the base weldment assembly. Install and tighten the four mounting nuts that secure the HDA to the base weldment assembly.
20. Install and tighten the bolt that secures the HDA to the bottom of the base weldment assembly.
21. Install the PCB support assembly on its six mounting studs. Install and tighten the six nuts securing the PCB support assembly to the base weldment assembly.
22. Connect connector J1 on the read/write PCB and J2 and J3 on the power amplifier PCB.
23. Install the R.H. and L.H. plenums to the PCB support assembly, secure them with the six mounting screws.

24. Install the front cover assembly, secure it with the three mounting screws. Connect connector J5 on the power control PCB.
25. Connect connectors J1, J2 and J3 on the power control PCB, connectors J1 and J2 on the control logic PCB, and connectors J2, J3, J4, and J5 on the spindle control PCB.
26. Close the drive (refer to paragraph 5.4).
27. Install the front panel (refer to paragraph 5.3).
28. Plug in the ac line cord, set the ac circuit breaker in the ON position.

### 5.18 TERMINATOR REMOVAL/REPLACEMENT

#### Removal

1. Power-down the disk drive (place the ON/OFF switch in the OFF position). Refer to Section 2 for the power-down procedure. Set the ac circuit breaker in the OFF position (located in the rear of the drive).
2. Remove the two screws that secure the terminator to its connector at the rear of the disk drive (refer to Figure 5-22).

#### Replacement

3. Connect the new terminator to its connector, tighten the two screws.
4. Set the ac circuit breaker in the ON position.

### 5.19 AC POWER CORD REMOVAL/REPLACEMENT

#### Removal

1. Power-down the disk drive (place the ON/OFF switch in the OFF position). Refer to Section 2 for the power-down procedure. Set the ac circuit breaker in the OFF position (located in the rear of the drive).
2. Unplug the ac power cord from the ac power source.
3. Unplug the ac power cord from the power supply in the rear of the drive (refer to Figure 5-22).

#### Replacement

4. Plug the ac power cord into the power supply in the rear of the drive (secure it in the plug retaining slot, refer to Figure 5-22).
5. Plug the ac power cord into the ac power source.

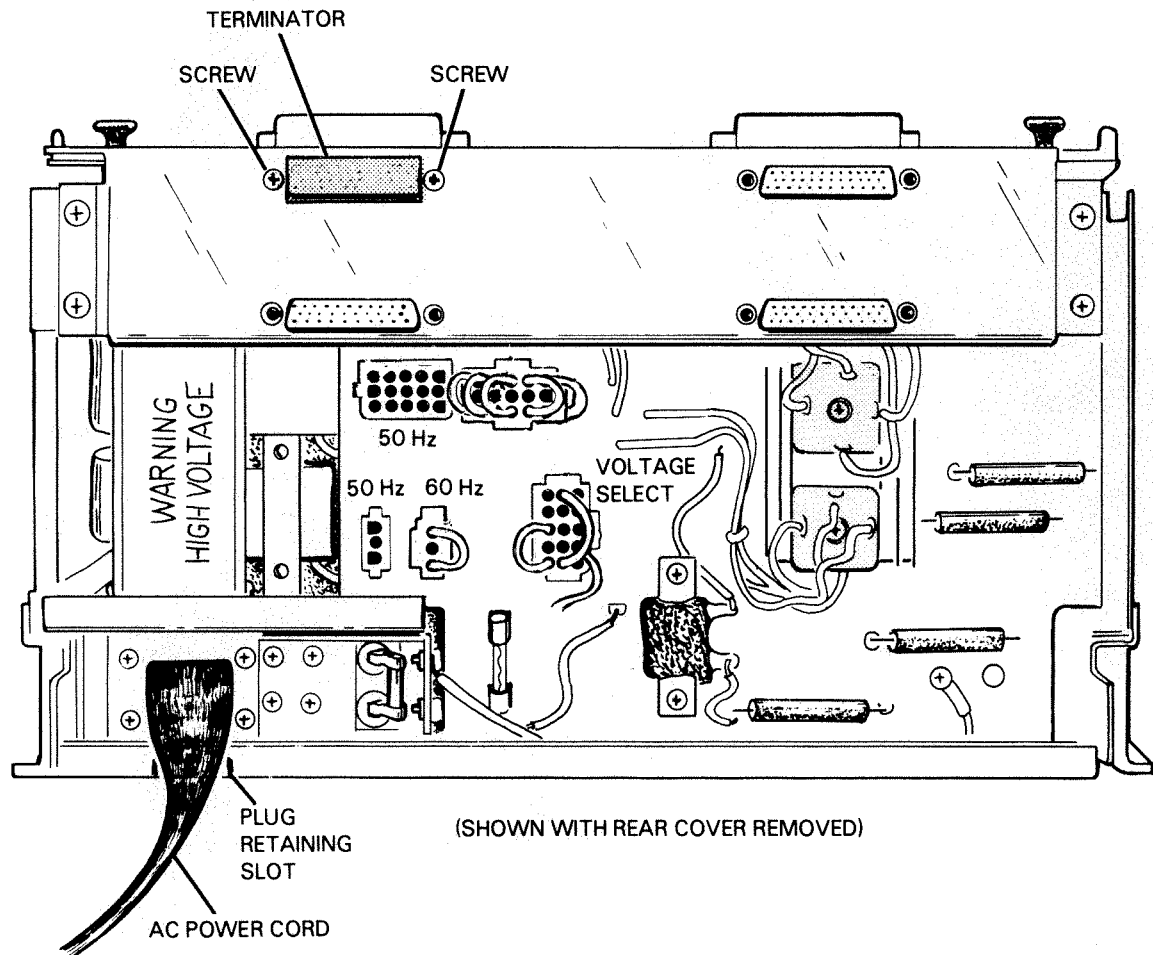

FS-07165

Figure 5-22. Terminator and AC Power Cord

## 5.20 METER HIGH CABINET REMOVAL/REPLACEMENT PROCEDURES (Model 6237)

The following paragraphs describe the procedures for the removal and replacement of the FRUs in the 6237 Meter High Cabinet.

### 5.20.1 Latch Assembly (Top and Rear) Removal/Replacement -

#### Removal

1. Power-down all three disk drives in the Meter High Cabinet (place the ON/OFF switch in the OFF position). Refer to Section 2 for the power-down procedure.
2. Place the Meter High Cabinet ON/OFF switch in the OFF position.

3. Set the ac circuit breaker in the rear of the cabinet in the OFF position (refer to Figure 5-23).
4. Remove the top weldment panel by inserting a screwdriver into the latches and push the latches toward the center of the cabinet. The panel can be removed when the latches are fully depressed.
5. Remove the rear weldment panel in the same manner as the top weldment panel.
6. Remove the two screws securing the latch assembly to the weldment panel (refer to Figure 5-23).
7. Pry outwards on the two plastic retaining tabs which protrude through the panel under the latch and pull up on the latch to remove the latch assembly from the weldment panel.

#### Replacement

8. Align the new latch assembly over the two holes in the weldment panel and snap the latch assembly into place.
9. Secure the latch assembly into place by installing and tightening the two screws.
10. Replace the top and/or the rear weldment panels.
11. Set the ac circuit breaker in the rear of the Meter High Cabinet (located on the power package) in the ON position.
12. Place the Meter High Cabinet ON/OFF switch in the ON position.

#### 5.20.2 Switch Assembly Removal/Replacement -

##### Removal

1. Power-down all three disk drives in the Meter High Cabinet (place the ON/OFF switch in the OFF position). Refer to Section 2 for the power-down procedure.
2. Place the Meter High Cabinet ON/OFF switch in the OFF position.
3. Set the ac circuit breaker in the rear of the cabinet in the OFF position (refer to Figure 5-24).
4. Unplug the Meter High Cabinet ac power cord.
5. Remove the top and rear weldment panels by inserting a screwdriver into the latches and push the latches toward the center of the cabinet (refer to Figure 5-24). The panel can be removed when the latches are fully depressed.
6. Remove the switch bezel by removing the two metal clips on the retaining tabs, push down on the retaining tabs and pull up on the top of the bezel (refer to Figure 5-24).

Data General Corporation (DGC) has prepared this manual for use by DGC personnel and customers as a guide to the proper installation, operation, and maintenance of DGC equipment and software. The drawings and specifications contained herein are the property of DGC and shall neither be reproduced in whole or in part without DGC's prior written approval nor be implied to grant any license to make, use, or sell equipment manufactured in accordance herewith.

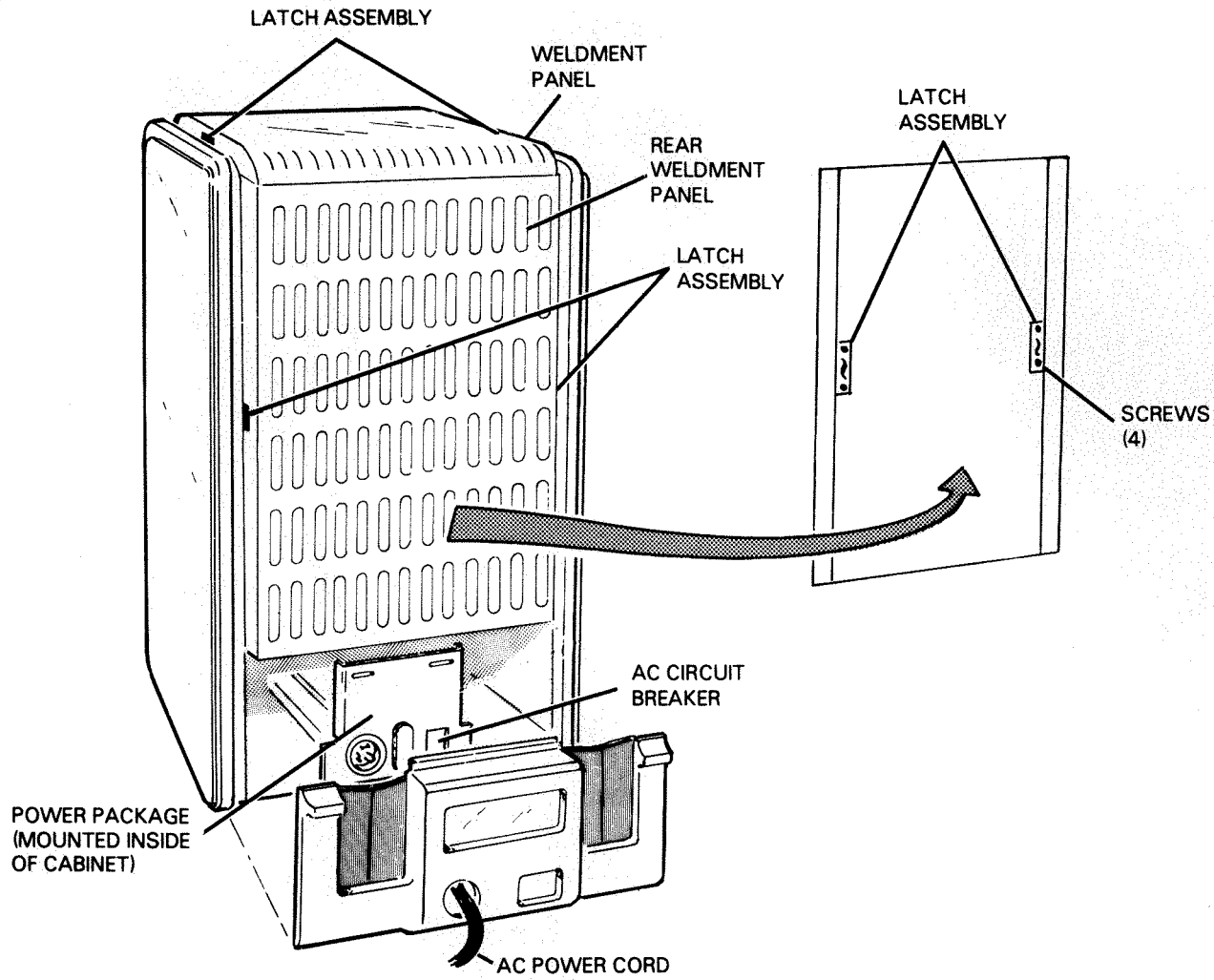

FS-07166

Figure 5-23. Latch Assembly

Data General Corporation (DGC) has prepared this manual for use by DGC personnel and customers as a guide to the proper installation, operation, and maintenance of DGC equipment and software. The drawings and specifications contained herein are the property of DGC and shall neither be reproduced in whole or in part without DGC's prior written approval nor be implied to grant any license to make, use, or sell equipment manufactured in accordance herewith.

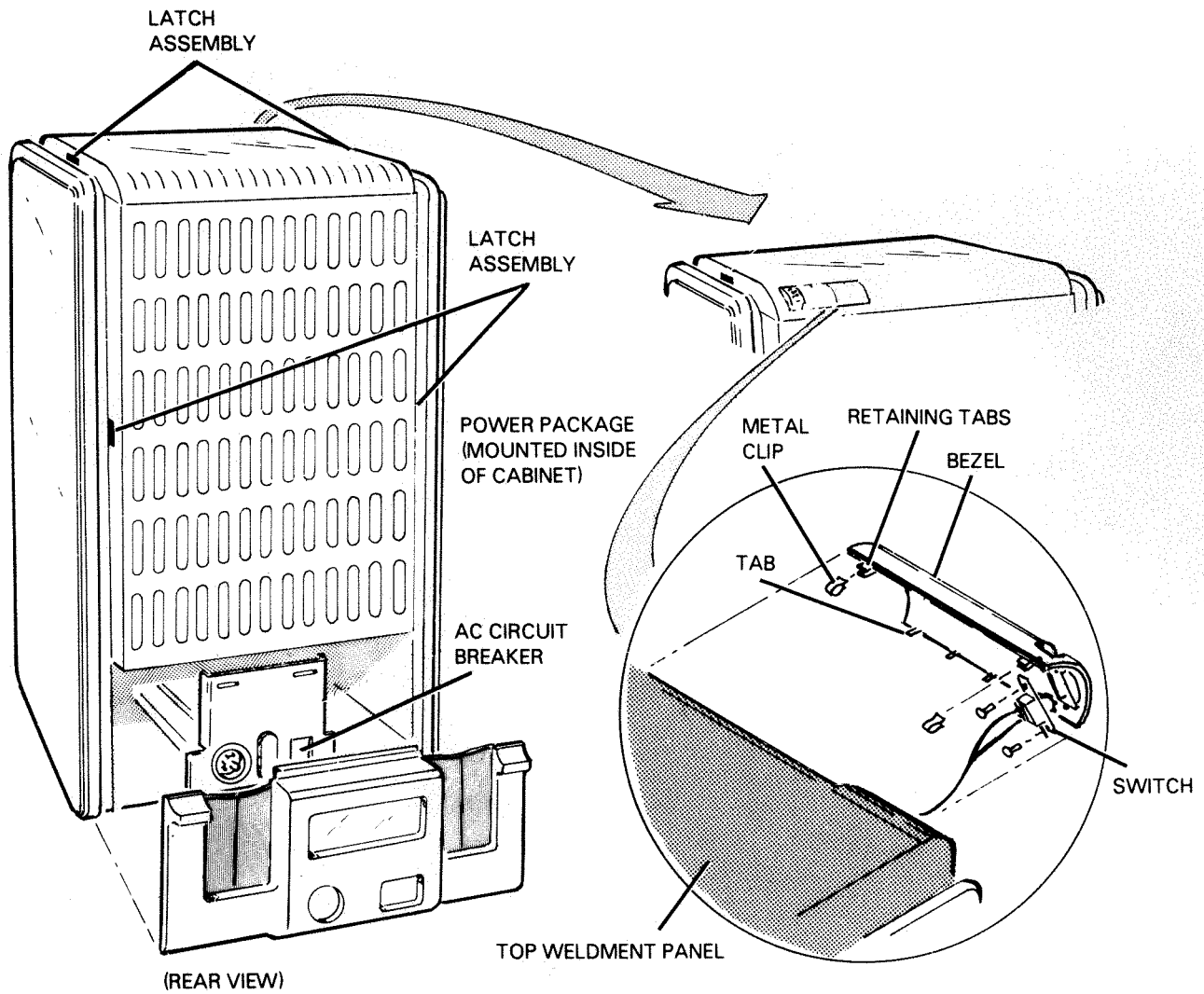

FS-07167

Figure 5-24. Switch Assembly



7. Unplug the switch wire harness from the power package.
8. Remove the wire harness from the frame by pulling it out of the clips along the side of the frame, cut off the ty-wraps on the top cross member.
9. Remove the switch from the bezel by removing the two screws that secure it.

#### Replacement

10. Secure the switch to the bezel by installing the two screws.
11. Replace the wire harness in the frame by securing it to the top cross member with two ty-wraps, push the harness into the clips on the side of the frame.
12. Install the harness plug into the power package.
13. Replace the switch bezel by inserting the bottom tabs into the cowl, snap the top of the bezel into place. Push the metal clips onto the plastic retaining clips.
14. Replace the top and rear panels by pushing them into place.
15. Plug in the Meter High Cabinet ac power cord.
16. Set the ac circuit breaker in the ON position.
17. Place the Meter High Cabinet ON/OFF switch in the ON position.

### 5.20.3 Power Package Fuse Removal/Replacement -

#### Removal

1. Power-down all three disk drives in the Meter High Cabinet (place the ON/OFF switch in the OFF position). Refer to Section 2 for the power-down procedure.
2. Place the Meter High Cabinet ON/OFF switch in the OFF position
3. Set the ac circuit breaker in the rear of the cabinet in the OFF position (refer to Figure 5-23).
4. Unplug the Meter High Cabinet ac power cord.
5. Push up on the two retaining tabs on the cable panel (located in the rear of the cabinet), pull out on the bottom of the panel, swing the panel upwards and pull the panel out to remove it from the cabinet. (Refer to Figure 5-25).
6. Remove the fuse(s), (F1, F2 and/or F3) from their fuse holder.

## Replacement

7. Install the new fuse(s), (F1, F2 and/or F3) in their fuse holder.
8. Install the cable panel to the rear of the cabinet.
9. Plug in the Meter High Cabinet ac power cord.
10. Set the ac circuit breaker in the ON position.
11. Place the Meter High Cabinet ON/OFF switch into the ON position.

### 5.20.4 Power Package AC Power Cord Removal/Replacement -

#### Removal

1. Power-down all three disk drives in the Meter High Cabinet (place the ON/OFF switch in the OFF position). Refer to Section 2 for the power-down procedure.
2. Place the Meter High Cabinet ON/OFF switch in the OFF position
3. Set the ac circuit breaker in the rear of the cabinet in the OFF position (refer to Figure 5-25).
4. Disconnect the ac power cord from the external ac power source.
5. Disconnect the ac power cord from the power package by turning the connector counter-clockwise and pull it out.

#### Replacement

6. Connect the ac power cord to the power package by inserting the connector into the receptical and turn it clockwise.
7. Connect the ac power cord to the external ac power source.
8. Set the ac circuit breaker in the ON position.
9. Place the Meter High Cabinet ON/OFF switch in the ON position.

### 5.20.5 Power Package Removal/Replacement -

#### Removal

1. Power-down all three disk drives in the Meter High Cabinet (place the ON/OFF switch in the OFF position). Refer to Section 2 for the power-down procedure.
2. Place the Meter High Cabinet ON/OFF switch in the OFF position.
3. Set the ac circuit breaker in the rear of the cabinet in the OFF position (refer to Figure 5-26).
4. Unplug the Meter High Cabinet ac power cord.

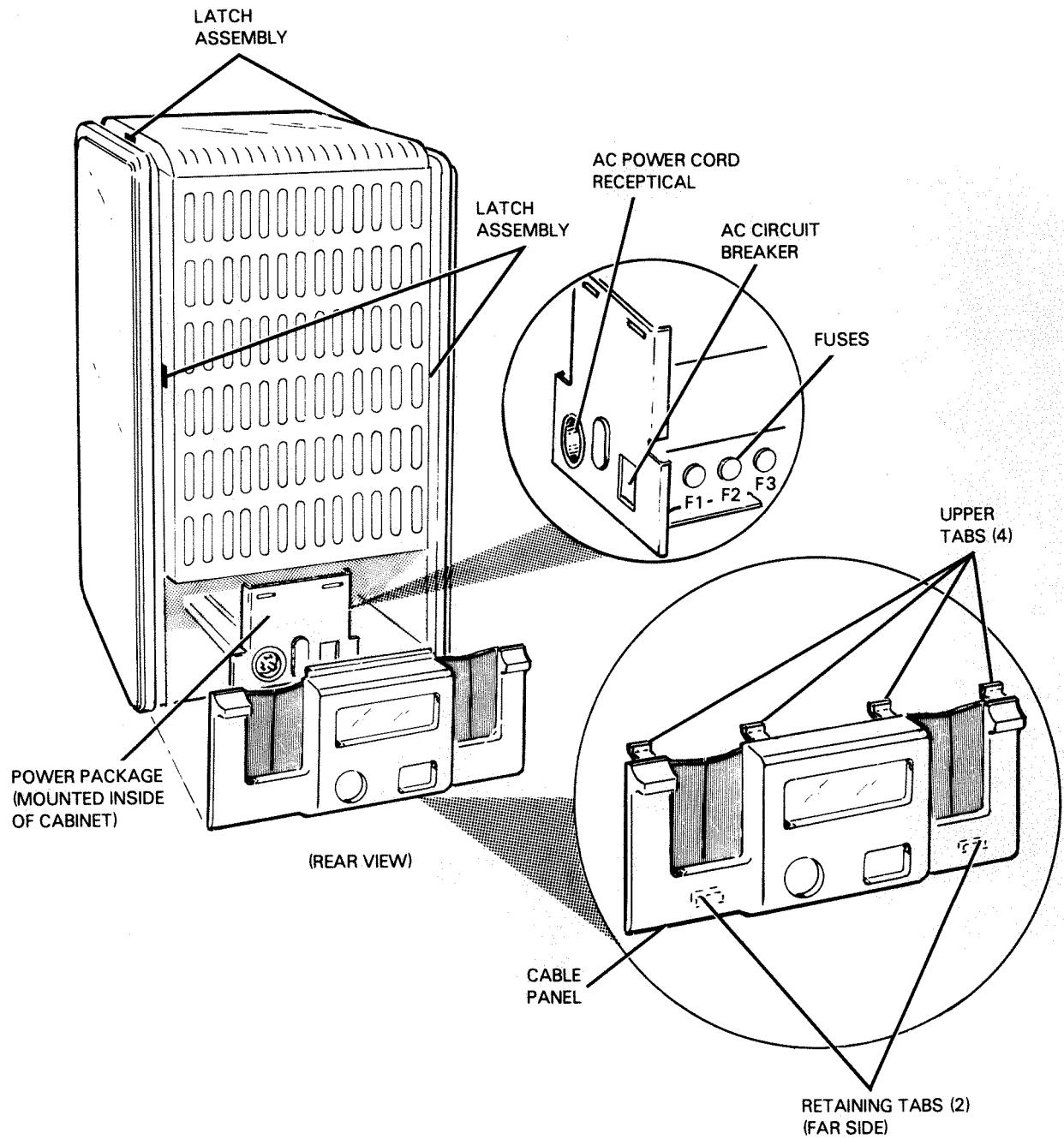

FS-07168

**Figure 5-25.** Fuse and AC Power Cord

Data General Corporation (DGC) has prepared this manual for use by DGC personnel and customers as a guide to the proper installation, operation, and maintenance of DGC equipment and software. The drawings and specifications contained herein are the property of DGC and shall neither be reproduced in whole or in part without DGC's prior written approval nor be implied to grant any license to make, use, or sell equipment manufactured in accordance herewith.

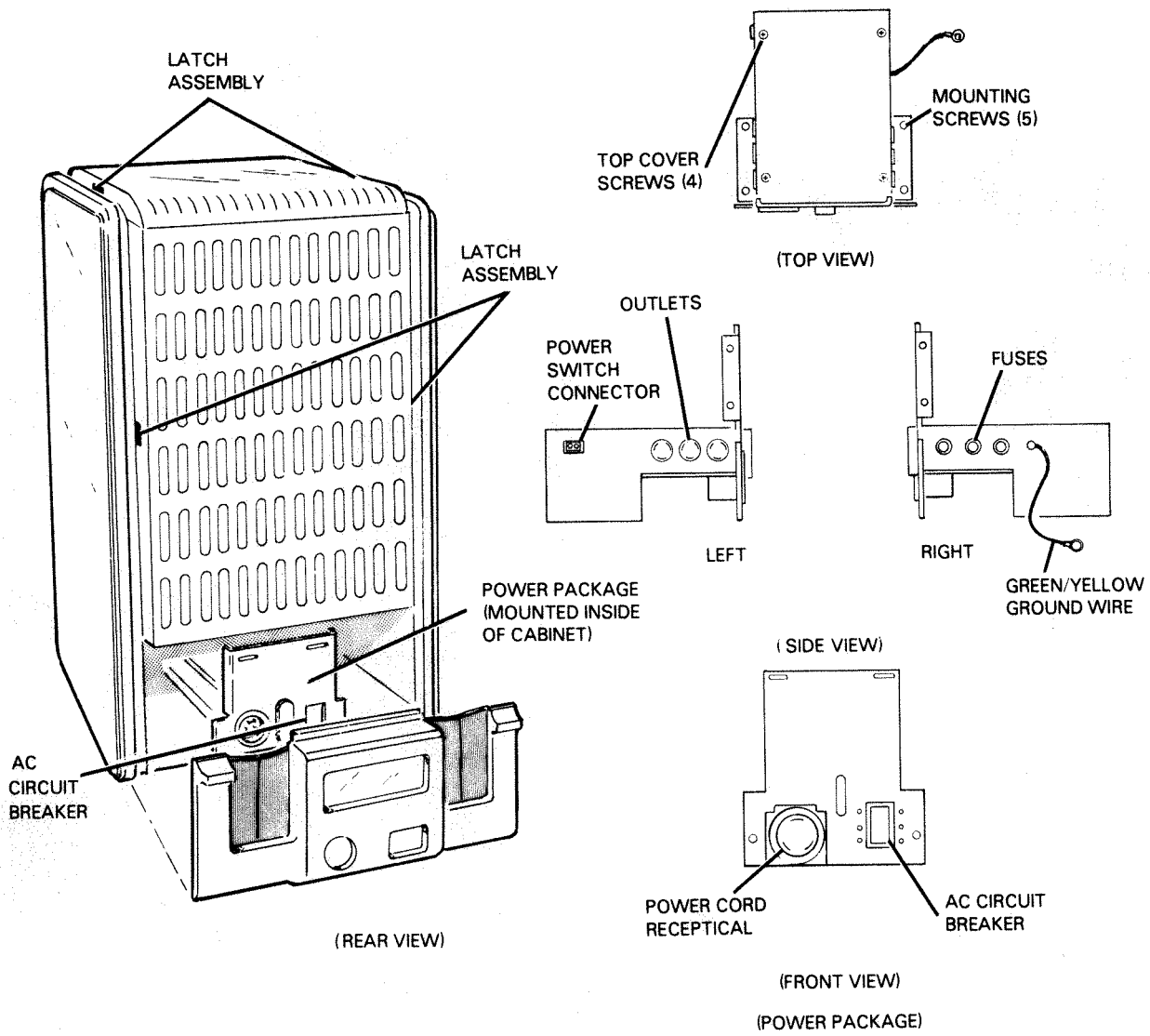

FS-07169

Figure 5-26. Power Package

5. Remove the front panel of the bottom drive in the Meter High Cabinet (refer to paragraph 5.3).
6. Remove the front grill on the Meter High Cabinet. Push up on the two retaining tabs, pullout on the bottom of the grill. When the bottom of the grill is detached, swing the grill outwards to detach the upper tabs.
7. Remove the two mounting screws securing the front cover to the installation cabinet, slide the drive forward and out of the installation cabinet (refer to paragraph 5.20).
8. Push up on the two retaining tabs on the cable panel (located in the rear of the cabinet), pull out on the bottom of the panel, swing the panel upwards and pull the panel out to remove it from the cabinet (refer to Figure 5-25).
9. Remove rear weldment panels by inserting a screwdriver into the latch and push the latch toward the center of the cabinet (refer to Figure 5-26). The panel can be removed when the latches are fully depressed.
10. Unplug all three disk drives from the ac outlets in the power package (refer to Figure 5-26).
11. Remove the green/yellow ground wire on the right side of the power package (refer to Figure 5-26).
12. Remove the power switch cable from the left side of the power package (refer to Figure 5-26).
13. Remove the two screws securing the rear plate to the frame. Remove the two screws securing the rear plate to the power package (refer to Figure 5-26).
14. Move the rear plate approximately 4 inches away from the frame to gain access to the power package wires.
15. On domestic disk drives remove the green/yellow wire from position "G" and the blue wire from position "W" on the rear of the ac power connector. On OUTSIDE USA drives remove the green/yellow wire from position #5 and the blue wire from position #4 on the terminal block.
16. Remove the brown wire from Pole #1 and the black wire from Pole #2 on the load side of the ac circuit breaker.
17. Remove the green/yellow wire from the back side of the rear plate.
18. Remove the green/yellow wire that grounds the power package to the base of the frame (refer to Figure 5-26).

19. Remove the four screws that secure the top cover to power package, remove the top cover.

#### CAUTION

When removing the power package from the frame cabinet be careful not to damage any wires.

20. Remove the five screws securing the power package to the base of the frame (refer to Figure 5-26 ). Carefully remove the power package from the frame.

#### Replacement

#### CAUTION

When installing the power package on the frame be careful not to damage any wires.

21. Install the new power package in its correct position on the frame. (Feed the wires through the hole in the base of the frame).
22. Install the five screws which secure the power package to the frame.
23. Install the top cover to the power package, secure it with the four screws.
24. Install the green/yellow wire to the base of the frame and the green/yellow wire to the back side of the rear plate.
25. Install the brown wire to Pole #1 and the black wire to Pole #2 on the load side of the ac circuit breaker.
26. On domestic disk drives install the green/yellow wire to position "G" and the blue wire to position "W" on the rear of the ac power connector. On OUTSIDE USA disk drives install the green/yellow wire to position #5 and the blue wire to position #4 on the terminal block.
27. Install the rear plate to the frame (secure it with the four mounting screws).
28. Plug in the power switch cable on the left side of the power package.
29. Plug in the three disk drives to the outlets on the power package.
30. Replace the rear panel weldment by putting it in position and pushing on it so that the latches engage and secure the panel.

Data General Corporation (DGC) has prepared this manual for use by DGC personnel and customers as a guide to the proper installation, operation, and maintenance of DGC equipment and software. The drawings and specifications contained herein are the property of DGC and shall neither be reproduced in whole or in part without DGC's prior written approval nor be implied to grant any license to make, use, or sell equipment manufactured in accordance herewith.

31. Install the cable panel to the rear of the cabinet.
32. Slide the drive (bottom position) into the Meter High Cabinet and secure it with the two cabinet mounting screws.
33. Install the front cover, install the front grill.
34. Plug in the Meter High Cabinet ac power cord.
35. Set the ac circuit breaker in the ON position.
36. Place the Meter High Cabinet ON/OFF switch into the ON position.

## SECTION 6

### INSTALLATION/REMOVAL

This section describes installation, initial checkout procedures, and removal instructions for the 6236/6237 disk drive subsystem. Service personnel should be familiar with the following information before performing installation/removal procedures.

There are two types of installation requirements for the 6236/6237 disk drive subsystem:

1. The disk drive subsystem is purchased with a computer and other equipment as a complete minicomputer system, and installed and shipped in an equipment cabinet. The complete subsystem is assembled and rigorously tested at the factory before being shipped. In general, such a system only needs to be placed in position; the padding material removed from inside and around the equipment; the shipping restraints removed; the carriage shipping lock removed; and the disk drive subsystem is ready to be powered up.
2. One or more 6236/6237 disk drive subsystems are purchased to expand a previously installed computer system. In this case, the on-site installation of a disk drive subsystem requires unpacking, rack mounting, proper cabling, and initial checkout procedures.

This section is organized into five major areas:

1. Site Preparation Requirements - describes the physical, electrical and environmental specifications of the disk drive.
2. Tools, Equipment, and Materials - lists the tools, materials, and equipment needed to install, check, and remove the disk drive subsystem.
3. Unpacking and Inspection - describes procedures for unpacking the disk drive, verifying equipment shipped, and initial inspection of the disk drive.
4. Installation - describes rack mounting procedures, controller PCB configuration jumpering and installation, power/interface connections and initial checkout.
5. Disk Drive Subsystem Removal - describes how to remove and repack the disk drive for shipment.



## 6.1 SITE PREPARATION REQUIREMENTS

This subsection describes the physical, electrical and environmental specifications of the disk drive subsystem.

6.1.1 Physical Specifications - Table 6-1 lists the physical specifications for the 6236/6237 disk drive. Figure 6-1 illustrates the dimensions of the 6236 disk drive and Figure 6-2 illustrates the dimensions for the 6237 disk drive. Figure 6-3 illustrates service dimensions for the 6236/6237 disk drive.

Table 6-1. Physical Specifications

DIMENSIONS			
6236			
	<u>Width</u>	<u>Depth</u>	<u>Height</u>
Centimeters:	48.3	75.9	26.7
Inches:	19	29.9	10.5
6237			
Centimeters:	64.5	89.1	102.8
Inches:	25.4	35.1	40.4
6236/6237 Controller PCB	38.2 x 38.2 cm (15 x 15 in)		
SERVICE CLEARANCE			
	6236/6237		
	<u>Front</u>	<u>Rear</u>	
Centimeters:	102	76.2	
Inches:	40	30	
WEIGHT			
	<u>6236</u>	<u>6237</u>	
Kilograms:	58.5	227	
Pounds:	130	500	
MOUNTING REQUIREMENTS			
6236:	Standard 48.3 cm (19.0 in) NEMA Rack		
6237:	Stand-Alone Meter High Cabinet		

Data General Corporation (DGC) has prepared this manual for use by DGC personnel and customers as a guide to the proper installation, operation, and maintenance of DGC equipment and software. The drawings and specifications contained herein are the property of DGC and shall neither be reproduced in whole or in part without DGC's prior written approval nor be implied to grant any license to make, use, or sell equipment manufactured in accordance herewith.

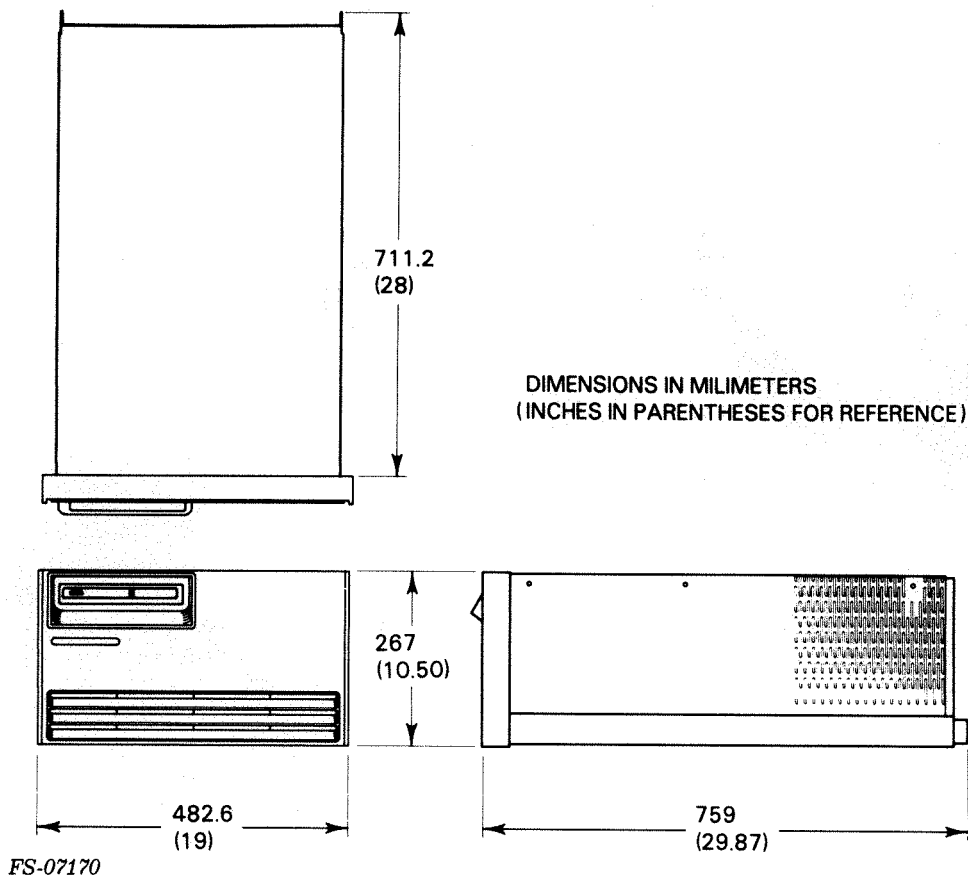

Figure 6-1. 6236 Disk Drive Dimensions

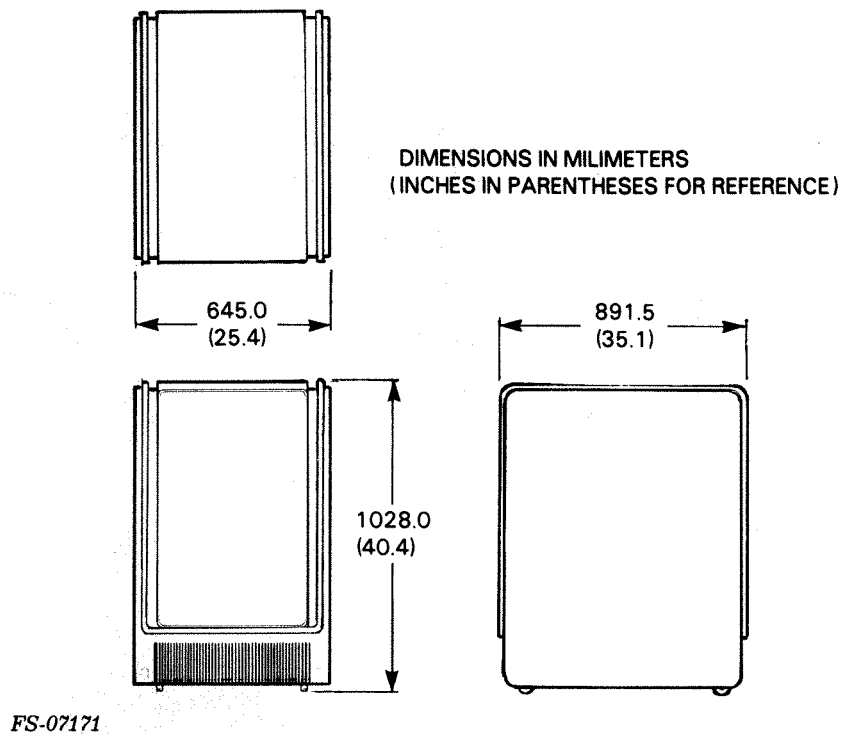
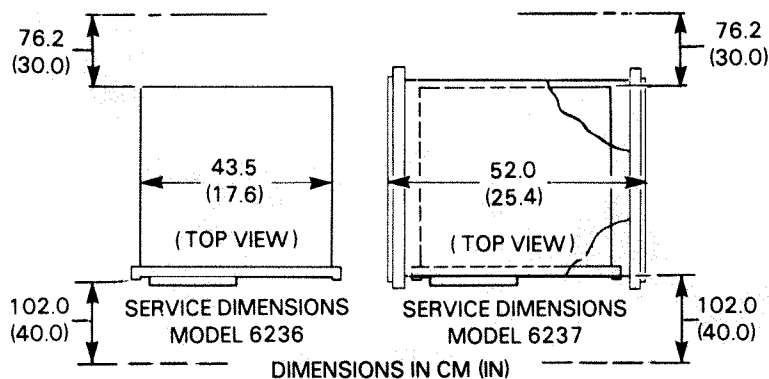

Figure 6-2. 6237 Disk Drive Dimensions

Data General Corporation (DGC) has prepared this manual for use by DGC personnel and customers as a guide to the proper installation, operation, and maintenance of DGC equipment and software. The drawings and specifications contained herein are the property of DGC and shall neither be reproduced in whole or in part without DGC's prior written approval nor be implied to grant any license to make, use, or sell equipment manufactured in accordance herewith.



FS-07172

Figure 6-3. 6236/6237 Disk Drive Service Dimensions

6.1.2 Electrical Specifications - Table 6-2 lists the electrical specifications of the disk drive and Table 6-3 lists ac power cable requirements.

Table 6-2. Electrical Specifications

POWER REQUIREMENTS					
	<u>6236</u>	<u>6236-1</u>	<u>6236-2</u>	<u>6236-4</u>	<u>6236-5</u>
Voltage (+10%/-15%):	120.0	100.0	220.0	240.0	100.0
Frequency (+/-1%):	60.0	50.0	50.0	50.0	60.0
Amps:	5.0	6.0	2.75	2.5	6.0
Startup Surge (35sec):	8.0	9.6	4.4	4.0	9.6
Phase:	1.0	1.0	1.0	1.0	1.0
(6236 Configuration)	<u>6237-B</u> <u>(3/6236)</u>	<u>6237-B1</u> <u>(3/6236-1)</u>		<u>6237-B5</u> <u>(3/6236-5)</u>	
Voltage (+10%/-15%):	120.0	120/240		120/240	
Frequency Amps:	15.0	18.0		18.0	
Startup Surge (35sec):	24.0	29.0		29.0	
Phase:	2.0	2.0		2.0	
(6236 Configuration)	<u>6237-C</u> <u>(3/6236)</u>	<u>6237-D2</u> <u>(3/6236-2)</u>		<u>6237-D4</u> <u>(3/6236-4)</u>	
Voltage (+10%/-15%):	120/208	220/380		220/380	
Frequency Amps:	15.0	8.25		7.5	
Startup Surge (35sec):	24.0	13.0		12.0	
Phase:	3.0	3.0		3.0	

015-000137

**Table 6-3. AC Power Cable Requirements**

6236	<u>USA</u> <u>POWER (60 HZ)</u>	<u>OUTSIDE USA</u> <u>POWER (50 HZ)</u>
	Length (Power Cord): 3 m (10 ft) (109-00719)	3 m (10 ft) (109-00681)
	Connector Type: 3 prong IEC 10 Amp	3 prong IEC 10 Amp
	Mating Connector Type: Std 3 prong outlet	Std 3 prong outlet
6237	<u>POWER (2 Phase)</u>	<u>POWER (3 Phase)</u>
	Length (Power Cord): 2.9 m (7.5 ft) (005-14760)	2.9 m (7.5 ft) (005-14372)
	Mating Connector Type:	
	Wall: L14-30R	L21-30R
	Drop: L14-30P	L21-30P

6.1.3 Environmental Specifications - The site must meet suitable environmental specifications for the disk drive subsystem to operate properly (refer to Table 6-4).

**Table 6-4. Environmental Specifications**

HEAT OUTPUT (max)/POWER CONSUMPTION					
	6236		6237		
	<u>WATTS</u>	<u>BTU/HR</u>	<u>WATTS</u>	<u>BTU/HR</u>	
100 V 50 Hz/6 A	600	2050	6150	1800	
100 V 60 Hz/6 A	600	2050	6150	1800	
120 V 60 Hz/5 A	600	2050	6150	1800	
220 V 50 Hz/6 A	600	2050	6150	1800	
240 V 50 Hz/2.5 A	600	2050	6150	1800	
TEMPERATURE RANGE					
Operating					
Room:	+10 degC to 38 degC (50 degF to 100 degF)				
Cabinet (max):	47 degC (117 degF)				
Change Rate:	10 degC (18 degF)/Hour				
Relative Humidity:	20% to 80% (noncondensing)				
Change Rate:	10%/hr				
Storage					
Disk Drive:	-40 degC to 65 degC (-40 degF to 149 degF)				
Relative Humidity:	10% to 90% (noncondensing)				
ALTITUDE					
Operating:	-1000 to 8000 ft (-304.8 to 2438 m)				
Storage:	-1000 to 25,000 ft (-304.8 to 7620 m)				

## 6.2 TOOLS, EQUIPMENT AND MATERIALS

The following tools and equipment are needed to install the 6236/6237 disk drive subsystem and to perform the initial operating checkout procedures:

Table 6-5. Tools and Test Equipment

DESCRIPTION	DGC PART NUMBER
DGC Engineer Tool Kit	005-012583
Voltage Multimeter	128-000786
Oscilloscope	PHILIPS PM 3212 or equivalent
Current ADES Media	

## 6.3 UNPACKING, CHECKLIST AND INSPECTION

The following subsections describe the unpacking procedure, equipment checklist verification, and initial inspection of the 6236/6237 disk drive subsystem.

### 6.3.1 Unpacking/Model 6236

#### WARNING

The 6236 drive weighs approx. 59 kilograms (130 lb).  
Two people are required for unpacking and installation.

#### NOTE

Save all packaging materials.

Remove the packaging from around the 6236 disk drive subsystem as shown in Figure 6-4. Remove the disk drive from the pallet and place it in a clean area.

Data General Corporation (DGC) has prepared this manual for use by DGC personnel and customers as a guide to the proper installation, operation, and maintenance of DGC equipment and software. The drawings and specifications contained herein are the property of DGC and shall neither be reproduced in whole or in part without DGC's prior written approval nor be implied to grant any license to make, use, or sell equipment manufactured in accordance herewith.

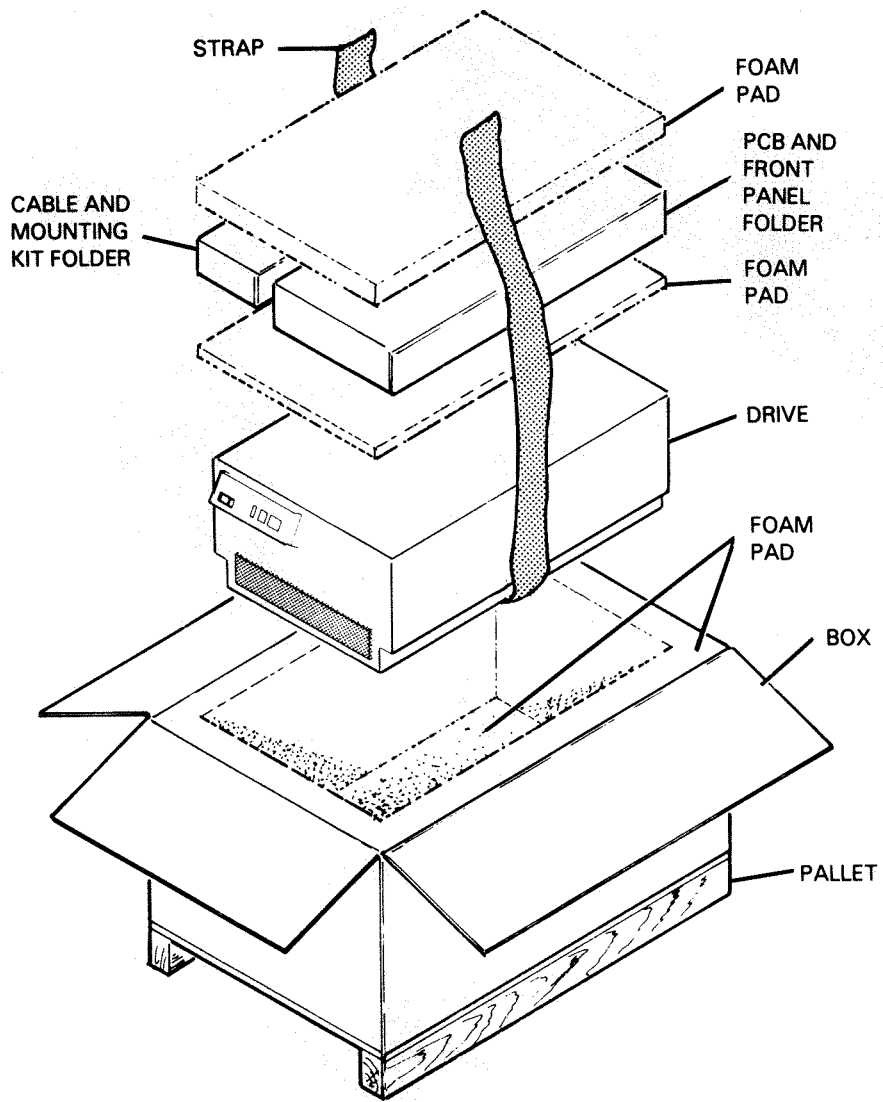

FS-07173

**Figure 6-4. 6236 Disk Drive Unpacking**

**NOTE**

Anti-tip bars are mounted in the cabinet as shown in Figure 6-5.

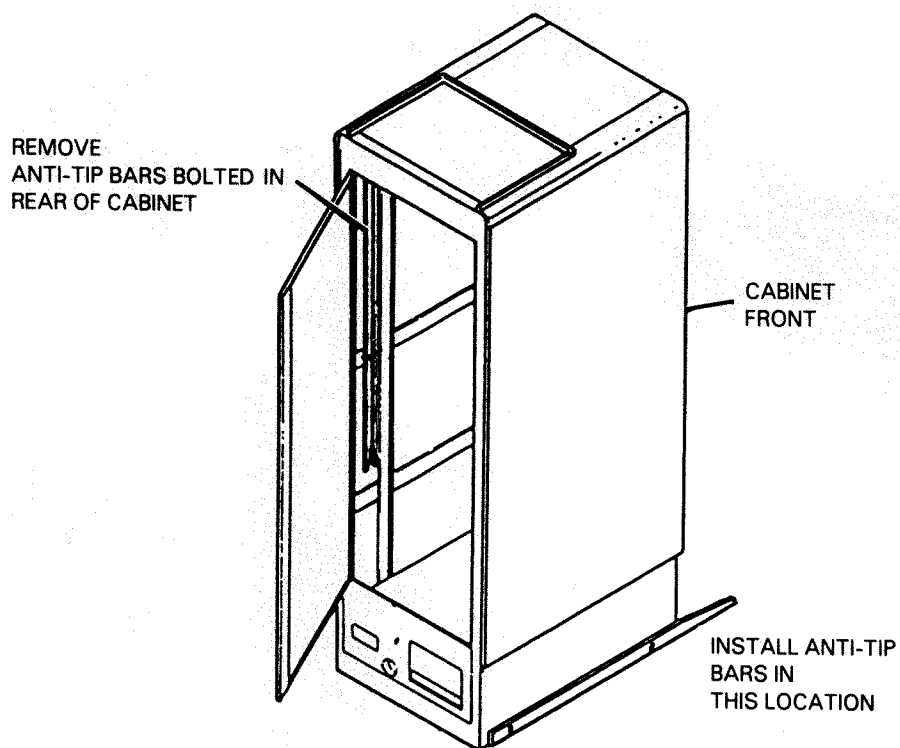

FS-07174

**Figure 6-5.** Anti-tip Bar Installation

### 6.3.2 Unpacking/Model 6237

#### **WARNING**

The 6237 drive weighs approximately 227 kilograms (500 lb). Care must be taken when unpacking the drive to avoid any possible physical injury.

#### **NOTE**

Save all packaging materials.

1. Remove the packaging from around the 6237 disk drive subsystem (refer to Figure 6-6).
2. Lower the ramp and position it as shown in Figure 6-7.
3. Remove bolts from shipping brackets, slide brackets to cut out. Remove shipping brackets.

Data General Corporation (DGC) has prepared this manual for use by DGC personnel and customers as a guide to the proper installation, operation, and maintenance of DGC equipment and software. The drawings and specifications contained herein are the property of DGC and shall neither be reproduced in whole or in part without DGC's prior written approval nor be implied to grant any license to make, use, or sell equipment manufactured in accordance herewith.

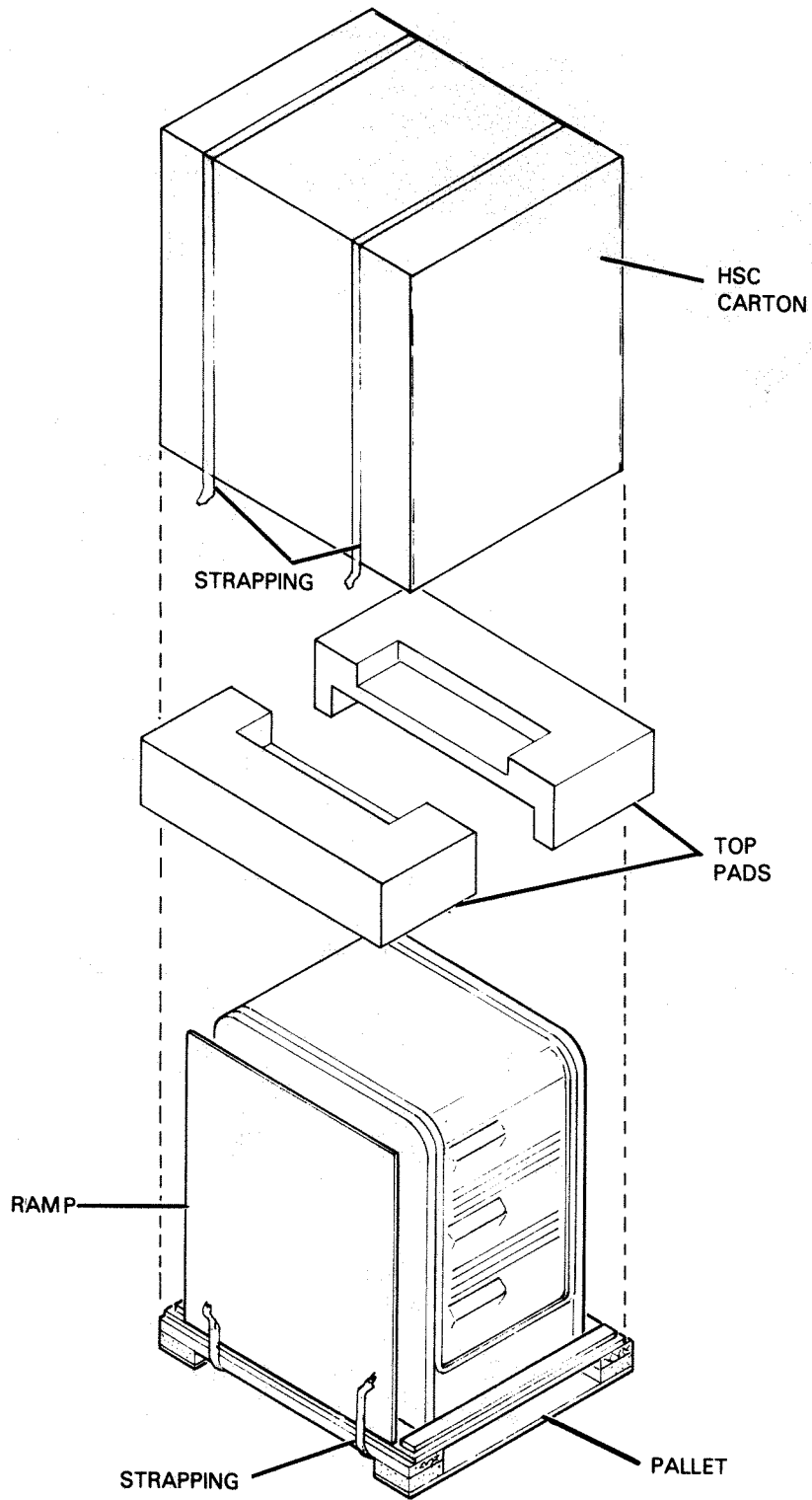

FS-07175

**Figure 6-6.** 6237 Disk Drive Unpacking



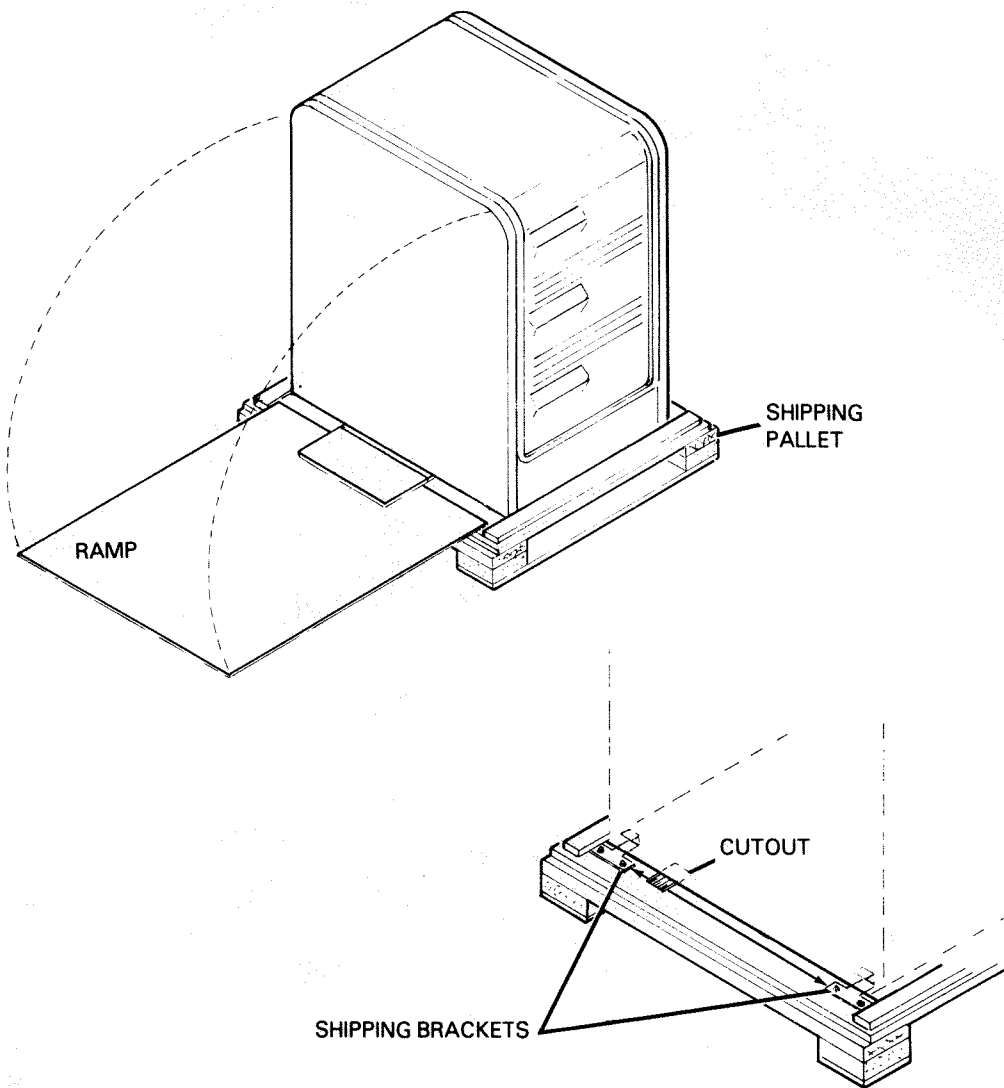

FS-07176

**Figure 6-7.** 6237 Disk Drive Removal

4. Carefully roll the disk drive off of the shipping pallet.

Data General Corporation (DGC) has prepared this manual for use by DGC personnel and customers as a guide to the proper installation, operation, and maintenance of DGC equipment and software. The drawings and specifications contained herein are the property of DGC and shall neither be reproduced in whole or in part without DGC's prior written approval nor be implied to grant any license to make, use, or sell equipment manufactured in accordance herewith.

### WARNING

Prior to installing the disk drive(s), be sure the installation cabinet's anti-tip bars are extended. Failure to do so may cause personal injury and/or equipment damage.

### NOTE

Anti-tip bars are mounted inside the Meter High Cabinet.

5. Carefully roll the disk drive to its installation position, extending the anti-tip bars (refer to Figure 6-8).

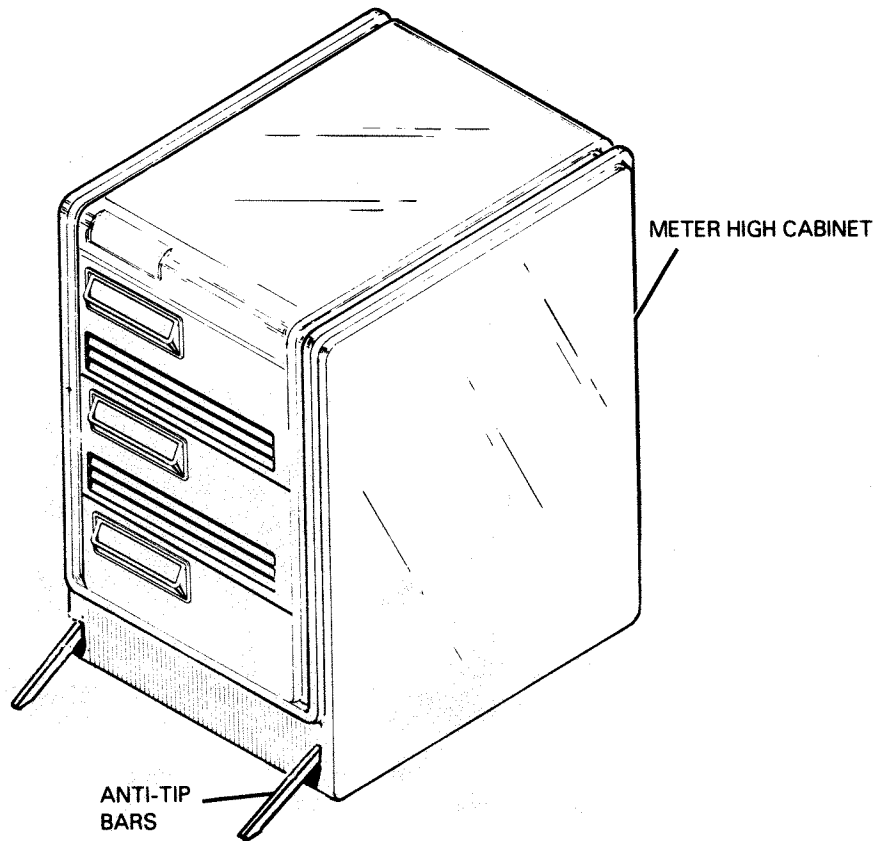

FS-07177

Figure 6-8. Meter High Cabinet Anti-tip Bars

### 6.3.3 Unpacking the Controller PCB

#### CAUTION

The 6236/6237 controller PCB contains metal-oxide semiconductor (MOS) integrated circuits (ICs). MOS chips can be damaged easily by a discharge of static electricity. Therefore, when handling MOS PCBs Service personnel should do the following:

1. Before removing the controller PCB from its protective shipping bag and/or before handling it, touch a solid ground to eliminate static charge.
2. Handle the PCB as little as possible when it is out of its protective shipping bag.
3. Avoid carpeted floors especially in low humidity areas.

#### NOTE

Save all packaging materials.

Remove packaging from the controller PCB shipping carton as shown in Figure 6-9.

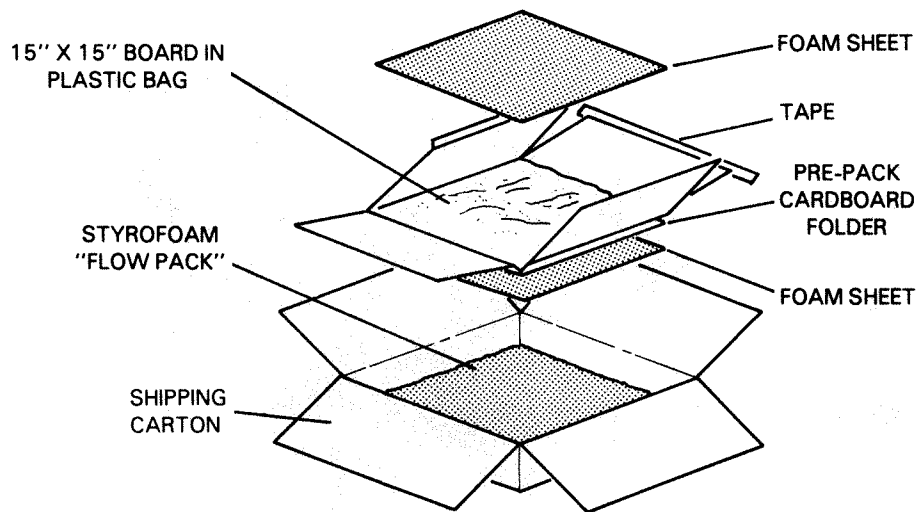

FS-04993

Figure 6-9. Controller PCB Packaging

6.3.4 Equipment Checklist and Initial Inspection - The preinstallation inspection consists of the the following procedure:

1. Inspect the drive for possible pre-shipment damage to the drive.
2. Take an inventory of all parts listed on the shipping bill accompanying the drive (refer to Figure 6-10).

Data General Corporation (DGC) has prepared this manual for use by DGC personnel and customers as a guide to the proper installation, operation, and maintenance of DGC equipment and software. The drawings and specifications contained herein are the property of DGC and shall neither be reproduced in whole or in part without DGC's prior written approval nor be implied to grant any license to make, use, or sell equipment manufactured in accordance herewith.

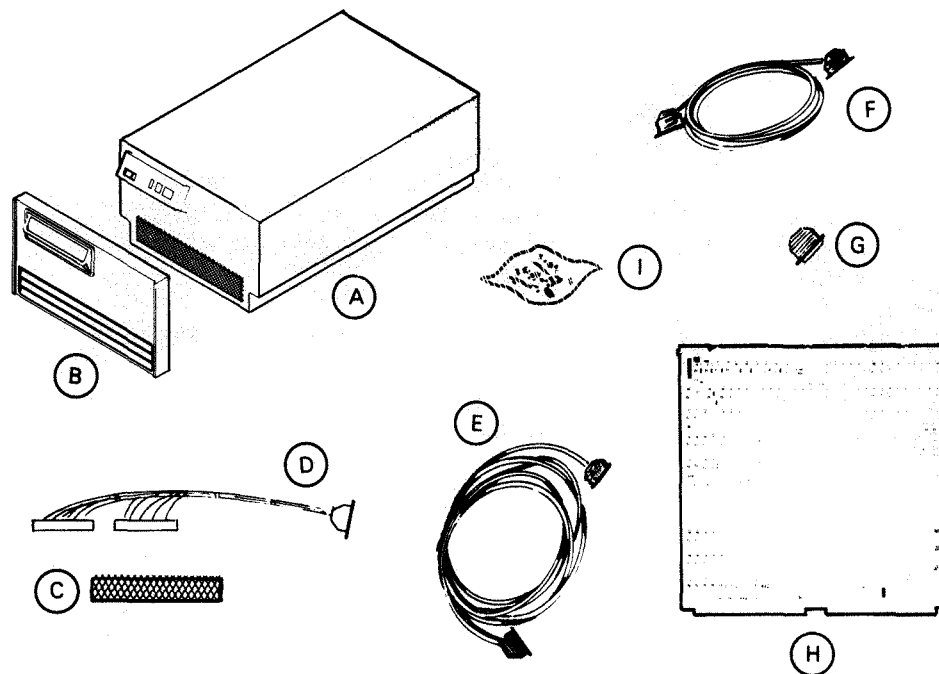

MAJOR COMPONENT

ITEM	COMPONENT	MOUNTING LOCATION	NOTES
A	RIGID DISK DRIVE	CABINET	
B	FRONT PANEL	CABINET	
C	COARSE AIR FILTER	CABINET	002-011044

CABLE

ITEM	CABLE	CONNECTING	MAX LGTH.		NOTES
			FT	M	
D	CPU INTERNAL CABLE	CPU BACKPANEL TO CPU BULKHEAD			SEE FIG 6-19
E	EXT I/O CABLE	CPU BULKHEAD TO DISK DRIVE			SEE FIG 6-19
F	DRIVE DAISY CHAIN CABLE	DISK DRIVE TO DISK DRIVE FOR MULTIPLE DRIVE SYSTEMS	6	1.8	005-20186
G	DRIVE TERMINATOR	PLUGS INTO DISK DRIVE			005-20105

ITEM	COMPONENT	CHASSIS	+5V CURRENT DRAW (AMPS)	NOTES
H	CONTROLLER PCB	CPU	.135	005-14278

ITEM	COMPONENT	NOTES
I	HARDWARE MOUNTING KIT	005-17817

FS-07178

Figure 6-10. Equipment Checklist

## 6.4 6236/6237 INSTALLATION

### WARNING

Prior to installing the disk drive(s), be sure the installation cabinet anti-tip bars are extended. Failure to do so may cause personal injury and/or equipment damage.

### CAUTION

The 6236/6237 disk drive subsystem must not be powered-up until the following procedures have been performed. Damage to the disk drive will result if the following procedures are not performed (refer to Figure 6-11):

1. Drive has stabilized to room temperature. Allow subsystem to temperature stabilize for 24 hours prior to power on. Leveling and cabling can be performed during this stabilizing period. If the installation time delay is critical allow the following minimum times for the HDA to warm to 22 degC (10 degF) with a site ambient temperature of 24 degC (75 degF) and 80 degF relative humidity (refer to Table 6-6).
2. Removal of the three shipping pre-load bolts (106-002135). (The bolts must be stored in the clip (002-024906) on the front cover.)
3. Removal of the carriage shipping lock (002-021004) and installation of the linear motor sealing screw (106-002136). (The carriage shipping lock must be stored in the fuse clip (113-000157) on the front cover.
4. Installation of two plugs (123-001975) on the bottom of the enclosure and one plug (123-002012) in the front panel.

Table 6-6. Temperature Stabilization

INITIAL TEMPERATURE	WAITING TIME
-40 degC (-40 degF)	23 hours
-23 degC (-10 degF)	21 hours
- 7 degC (+20 degF)	19 hours
+10 degC (+50 degF)	14 hours

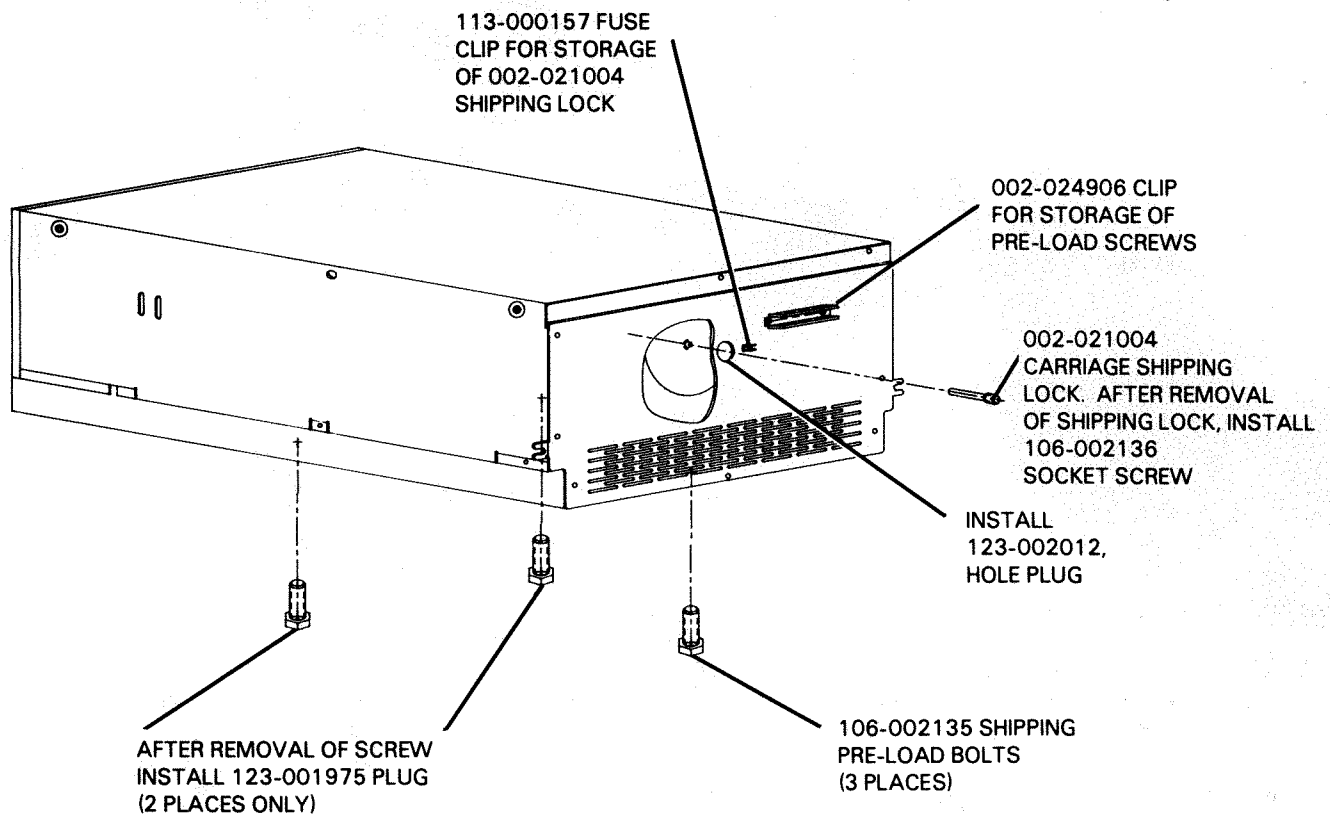

FS-07179

Figure 6-11. Shipping Restraints

**NOTE**

The following CPUs must contain these DG numbered NPU and IOC PCBs. If they are not installed, an operational error condition will result.

- MV/4000 - NPU PCB: DG PART #005-20709
- MV/6000, MV/8000, MV/8000II - IOC PCB: DG PART #005-20710

**NOTE**

To operate a 6236/6237 disk drive subsystem on an MV/4000 (non-floating point or with floating point), microcode MV/4000 Rev. 2.07 or above must be loaded.

6.4.1 Controller PCB Jumpering and Installation - The following paragraphs describe controller PCB jumpering and installation.

6.4.1.2 Controller PCB Jumpering

**NOTE**

For information on the Burst Multiplexor Channel Interface (BMCi) priority refer to the host CPU Product Summary and/or Installation and Packaging for Data General Corporation Peripherals (014-730).

Prior to installation into the host CPU chassis, the controller PCB must be jumpered. Refer to Figure 6-12 for information on controller PCB jumpering.

6.4.1.3 Controller PCB Installation

After jumpering the controller PCB, install the controller PCB into the host CPU chassis.

6.4.2 Model 6236 Installation Procedure - Before the 6236 disk drive can be rack mounted and powered-up in the equipment cabinet the following procedures must be performed:

- Removal of shipping pre-load bolts, carriage shipping lock and installation of linear motor sealing screw.

Before installing the disk drive into the equipment cabinet and before powering it up the disk drive shipping restraints must be removed. Refer to Figure 6-11.

1. Remove the three shipping pre-load bolts and store them on the clip on the front panel. Install the plugs in two places as shown.
2. Remove the carriage shipping lock and store it in the fuse clip on the front panel.
3. Install the linear motor sealing screw, install hole plug in front cover as shown.

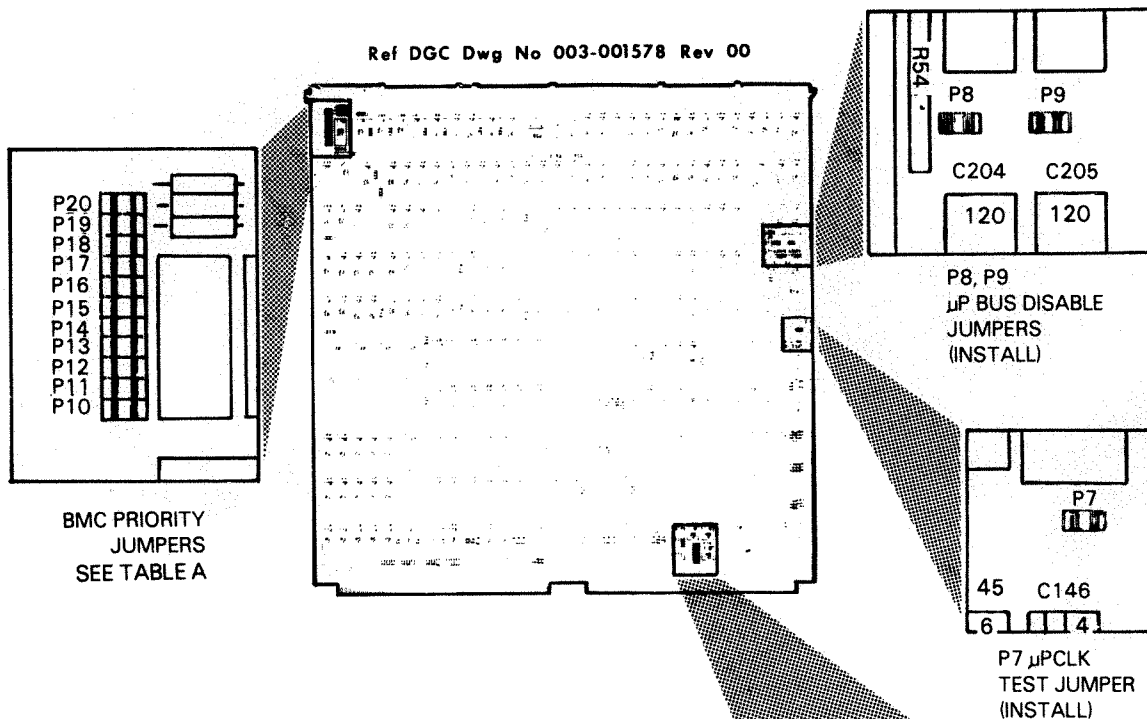
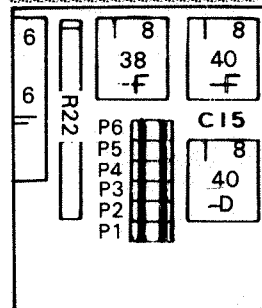

TABLE A BMCI BUS PRIORITY JUMPERS

PRIORITY	INSTALLED JUMPERS
(HIGHEST)	
HSCR 7	P17 P18 P19 P20
HSCR 6	P16 P18 P19
HSCR 5	P15 P18 P20
HSCR 4	P14 P18
HSCR 3	P13 P19 P20
HSCR 2	P12 P19
HSCR 1	P11 P20
HSCR 0 (LOWEST)	P10

*only valid on MW4000*



DEVICE CODE SELECT SEE TABLE B

TABLE B DEVICE CODE SELECT JUMPERS (JUMPER IN = 1, OUT = 0)

DEVICE CODE	MSB					LSB
	P1	P2	P3	P4	P5	
PRIMARY = 24	0	1	0	1	0	0
SECONDARY = 64	1	1	0	1	0	0

OTHER DEVICE CODES ASSIGNED PER OCTAL ARRANGEMENT OF P1→P6.

FS-07146

Figure 6-12. Controller PCB Jumpering



- Power Supply Jumpering Configuration and Internal Switch Positions

Before installing the disk drive the power supply jumpering configuration must be verified and the internal switches must be set in the correct operating position.

**NOTE**

Refer to Section 2 for detailed information on internal switches.

1. Remove the rear cover of the disk drive to gain access to the power supply assembly (refer to Figure 6-13). Verify that the power supply is jumpered in the correct voltage configuration (refer to Figure 6-14).

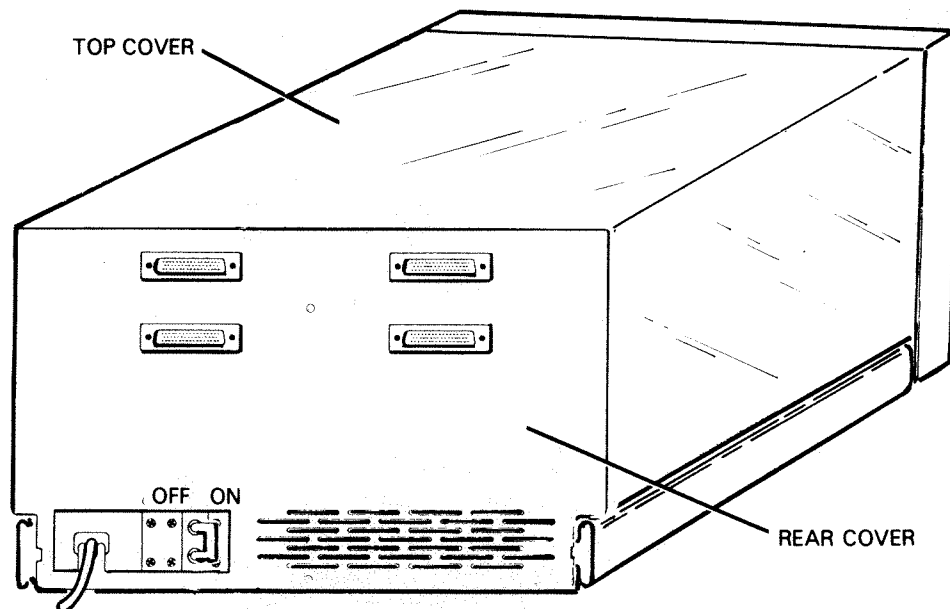
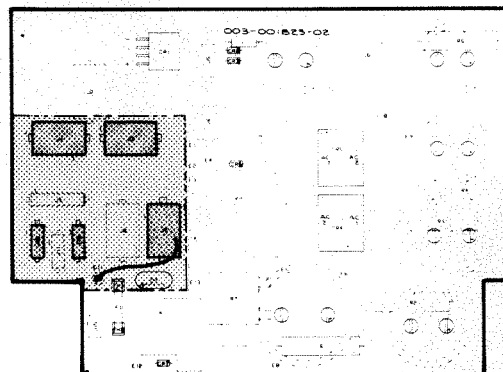
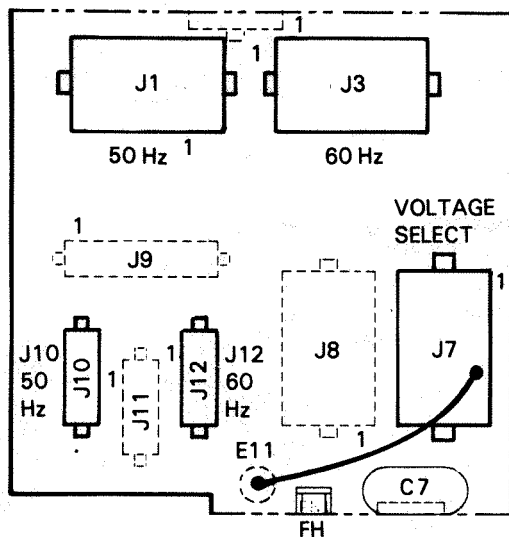

Figure 6-13. Rear Cover

2. Replace the power supply protective cover (if removed), install the rear cover.
3. Set the write protect switch on the read/write PCB to the Write Enable position and the disable switch on the power amplifier PCB to the Normal Operation position (refer to Figure 6-15). (Gain access through the holes in the top cover.)
4. Depress the two tabs on the sides of the front panel assembly and remove the panel from the chassis (refer to Figure 6-16).
5. Set front panel switches SW3 and SW4 to the OFF position (normal operating position). Set SW1 and SW2 to the appropriate disk drive unit number 0 to 3 (refer to Figure 6-17). Install front panel.

Data General Corporation (DGC) has prepared this manual for use by DGC personnel and customers as a guide to the proper installation, operation, and maintenance of DGC equipment and software. The drawings and specifications contained herein are the property of DGC and shall neither be reproduced in whole or in part without DGC's prior written approval nor be implied to grant any license to make, use, or sell equipment manufactured in accordance herewith.

**CHASSIS POWER**  
 Ref DGC Dwg No 003-001823 Rev 02



**VOLTAGE / FREQUENCY TAILORING**

VOLTAGE SYSTEM	AC BRKR PART NO.	VOLTAGE, JUMPER PLUG ASSY	LINE CORD P/N	FREQ STUNT PLUG (005-020121) POSITIONS ON 003-001823
240V/50HZ	113-000291	005-020194	109-000681	J1, J10
220V/50HZ	113-000291	005-020195	109-000681	J1, J10
100V/50HZ	113-000113	005-020197	109-000719	J1, J10
100V/60HZ	113-000113	005-020198	109-000719	J3, J12
120V/60HZ	113-000113	005-020196	109-000719	J3, J12
		NOTE 1		NOTE 2

NOTE 1: ON ALL JUMPER PLUG ASSEMBLIES, RING TONGUE PIGTAIL CONNECTS TO E11 ON 003-001823 PCB.

NOTE 2: FREQ STUNT PLUG ASSY 005-020121 CONSISTS OF TWO PLUGS, A 3-PIN AND A 15-PIN. THEY ARE ALWAYS ON THE PCB, AND THEIR POSITIONS CHANGE AS SHOWN FOR 50 OR 60 HZ.

FS-07181

**Figure 6-14. Power Supply Voltage Configuration**

Data General Corporation (DGC) has prepared this manual for use by DGC personnel and customers as a guide to the proper installation, operation, and maintenance of DGC equipment and software. The drawings and specifications contained herein are the property of DGC and shall neither be reproduced in whole or in part without DGC's prior written approval nor be implied to grant any license to make, use, or sell equipment manufactured in accordance herewith.

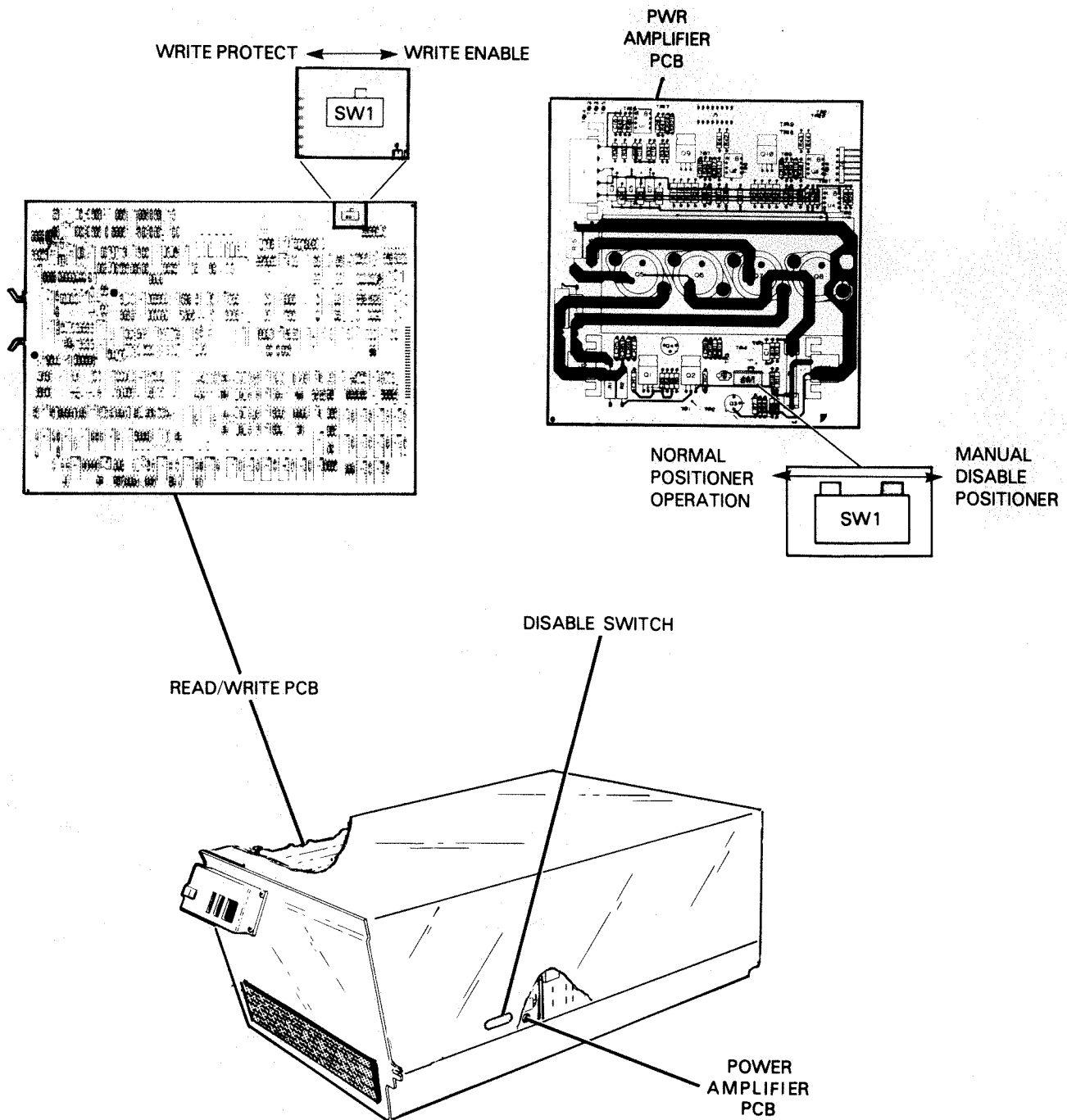

FS-07182

Figure 6-15. Write Protect and Disable Switches

Data General Corporation (DGC) has prepared this manual for use by DGC personnel and customers as a guide to the proper installation, operation, and maintenance of DGC equipment and software. The drawings and specifications contained herein are the property of DGC and shall neither be reproduced in whole or in part without DGC's prior written approval nor be implied to grant any license to make, use, or sell equipment manufactured in accordance herewith.

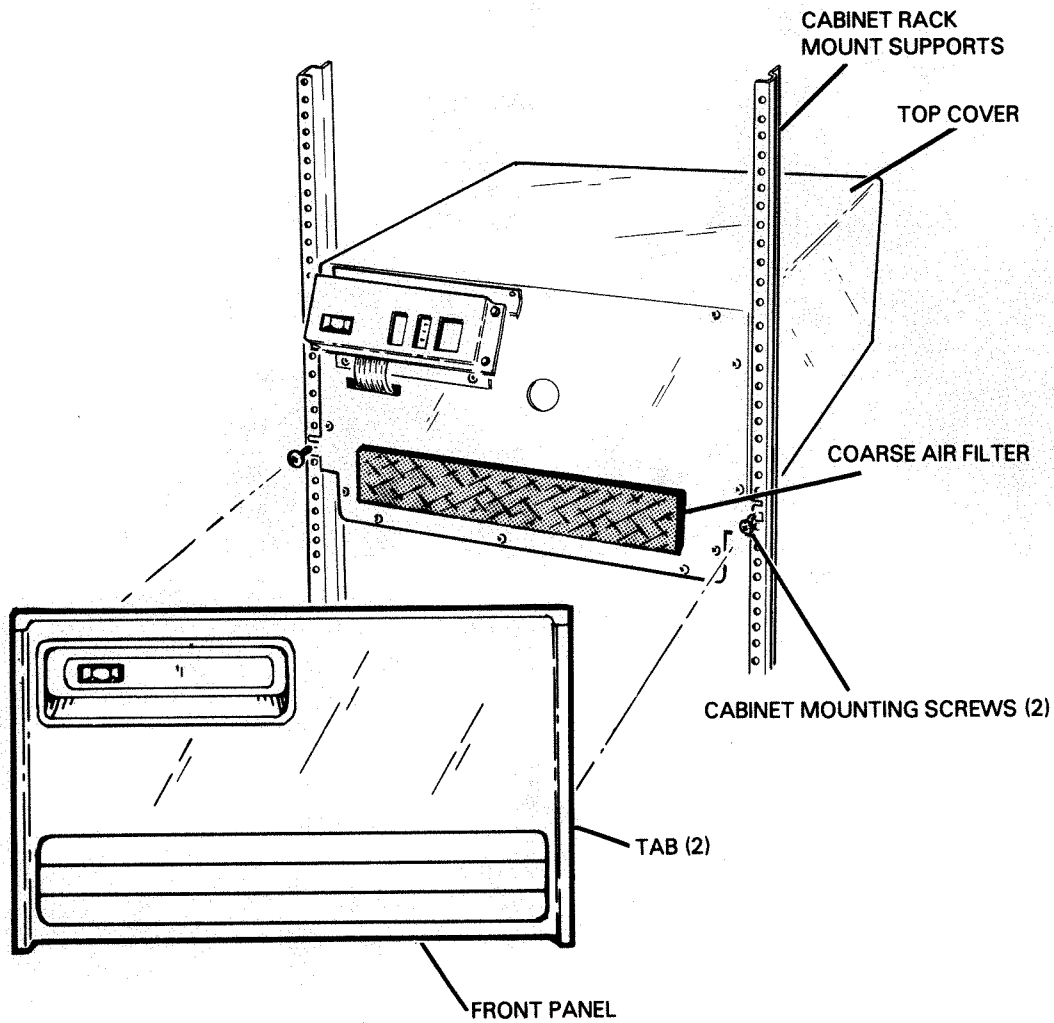

FS-07183

Figure 6-16. Top Cover

Data General Corporation (DGC) has prepared this manual for use by DGC personnel and customers as a guide to the proper installation, operation, and maintenance of DGC equipment and software. The drawings and specifications contained herein are the property of DGC and shall neither be reproduced in whole or in part without DGC's prior written approval nor be implied to grant any license to make, use, or sell equipment manufactured in accordance herewith.

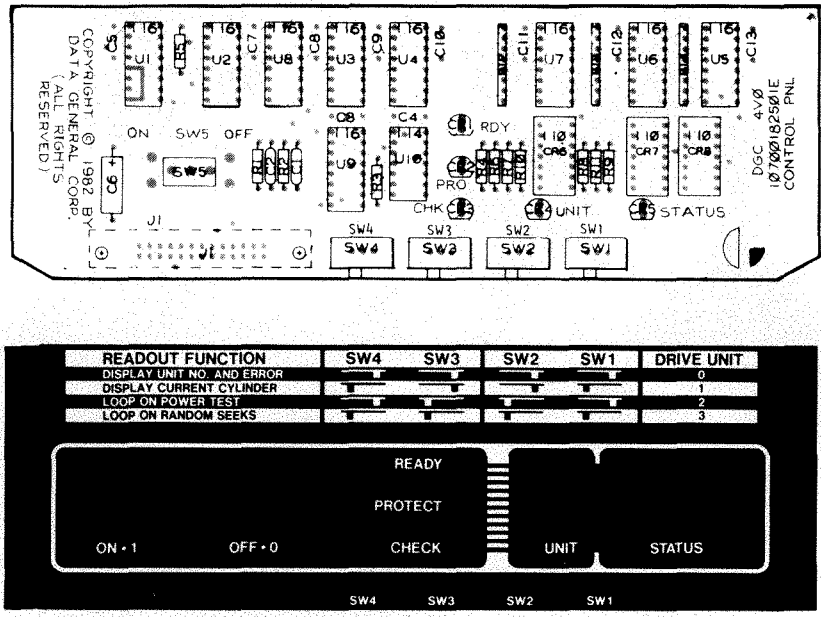

NOTE: READ OUT FUNCTIONALITY OF SWITCHES OBSERVED WITH FRONT PANEL REMOVED. SELECT DISPLAY READOUT/FUNCTION PER SW4, SW3 SELECT UNIT NUMBER PER SW1, SW2.

FS-07184

Figure 6-17. Front Panel Switches (SW1 to SW4)

6.4.2.1 Rack Mounting Procedure

**WARNING**

The 6236 drive weighs approximately 59 kilograms (130 lb). Two people are required for rack mounting.

Refer to Figure 6-18 for information on the rack mounting procedure.

6.4.2.2 I/O Cabling and AC Power Cord Connection - The controller PCB will support up to four 6236 disk drives. A terminator must be installed in the last drive in the daisy chain. Refer to Figure 6-19 for I/O cabling and ac power cord connection information.

FS-07185

6-23

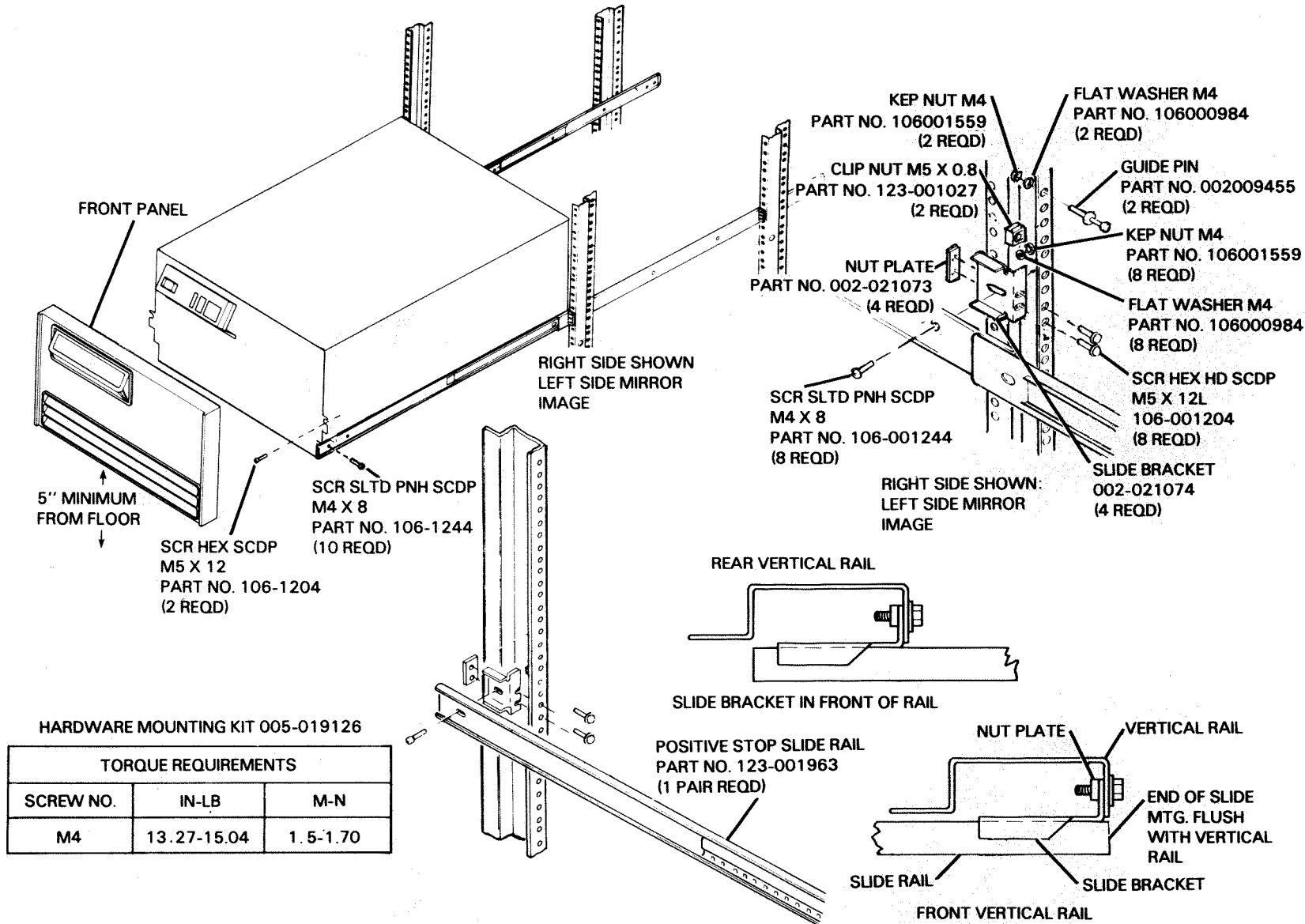

Figure 6-18. 6236 Rack Mounting

015-000137

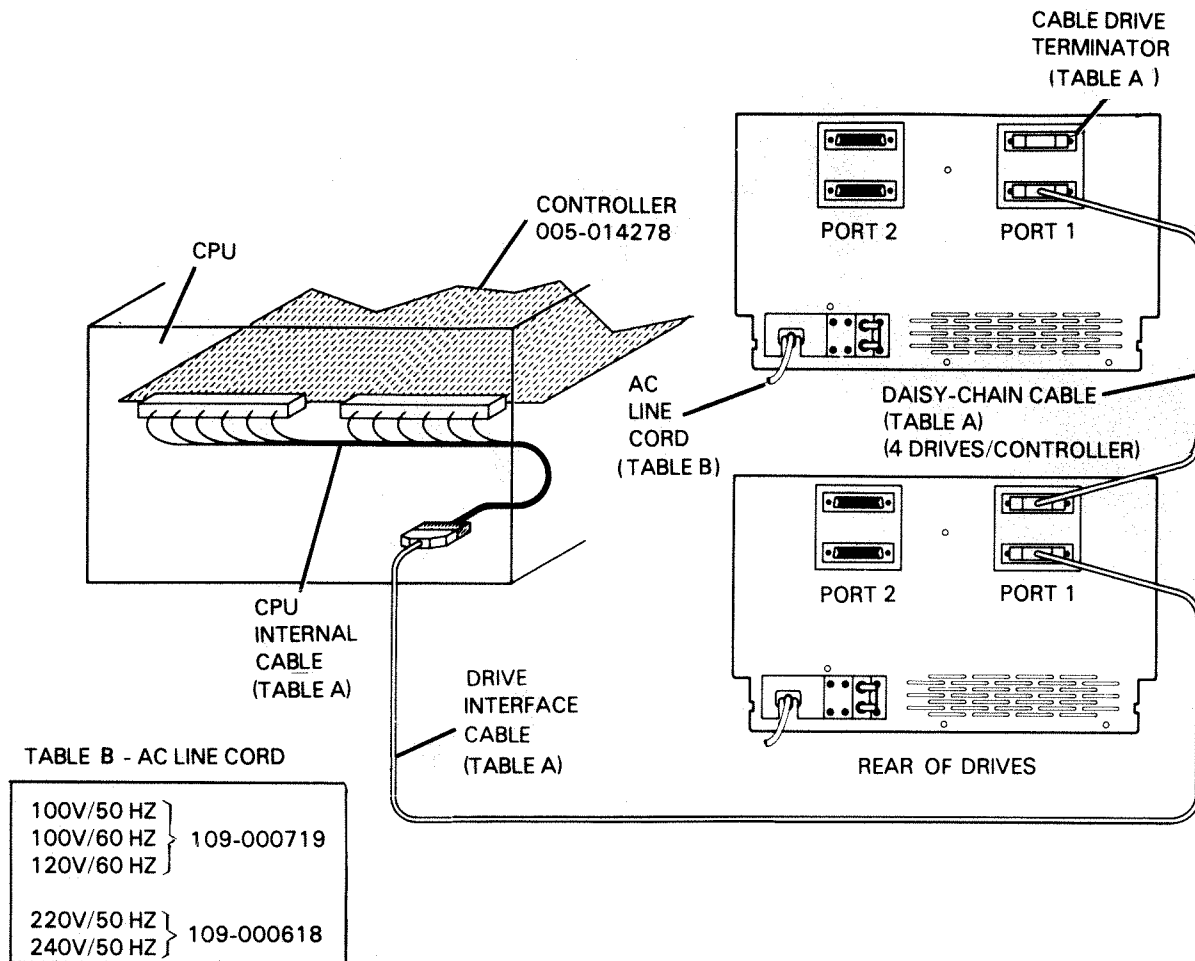

TABLE A (CPU INTERNAL & INTERFACE CABLES)

CPU DESIGNATOR	CPU TYPE	CPU INTERNAL CABLE	EXTERNAL CABLES			
			10'	20'	30'	40'
13-14	M600	005-020216	005-020298	005-020631	005-020632	005-020633
13-14	S250	005-020216	005-020298	005-020631	005-020632	005-020633
13-14	S350	005-020216	005-020298	005-020631	005-020632	005-020633
13-14	MV8000	005-020216	005-020298	005-020631	005-020632	005-020633
22-22	MV6000	005-020216	005-020298	005-020631	005-020632	005-020633
22-22	S140	005-020216	005-020298	005-020631	005-020632	005-020633
70-89	S280	005-020104	005-018480	005-021154	005-020629	005-020630
70-89	MV4000	005-020104	005-018480	005-021154	005-020629	005-020630
70-89	MV10000	005-020104	005-018480	005-021154	005-020629	005-020630
70-89	MV8000 II	005-020104	005-018480	005-021154	005-020629	005-020630
ALL CPUS	6' DRIVE DAISY CHAIN CABLE - 005-020186 DRIVE TERMINATOR - 005-020105					

FS-07186

Figure 6-19. 6236 I/O Cabling and AC Power Cord Connection (Sheet 1 of 2)

Data General Corporation (DGC) has prepared this manual for use by DGC personnel and customers as a guide to the proper installation, operation, and maintenance of DGC equipment and software. The drawings and specifications contained herein are the property of DGC and shall neither be reproduced in whole or in part without DGC's prior written approval nor be implied to grant any license to make, use, or sell equipment manufactured in accordance herewith.

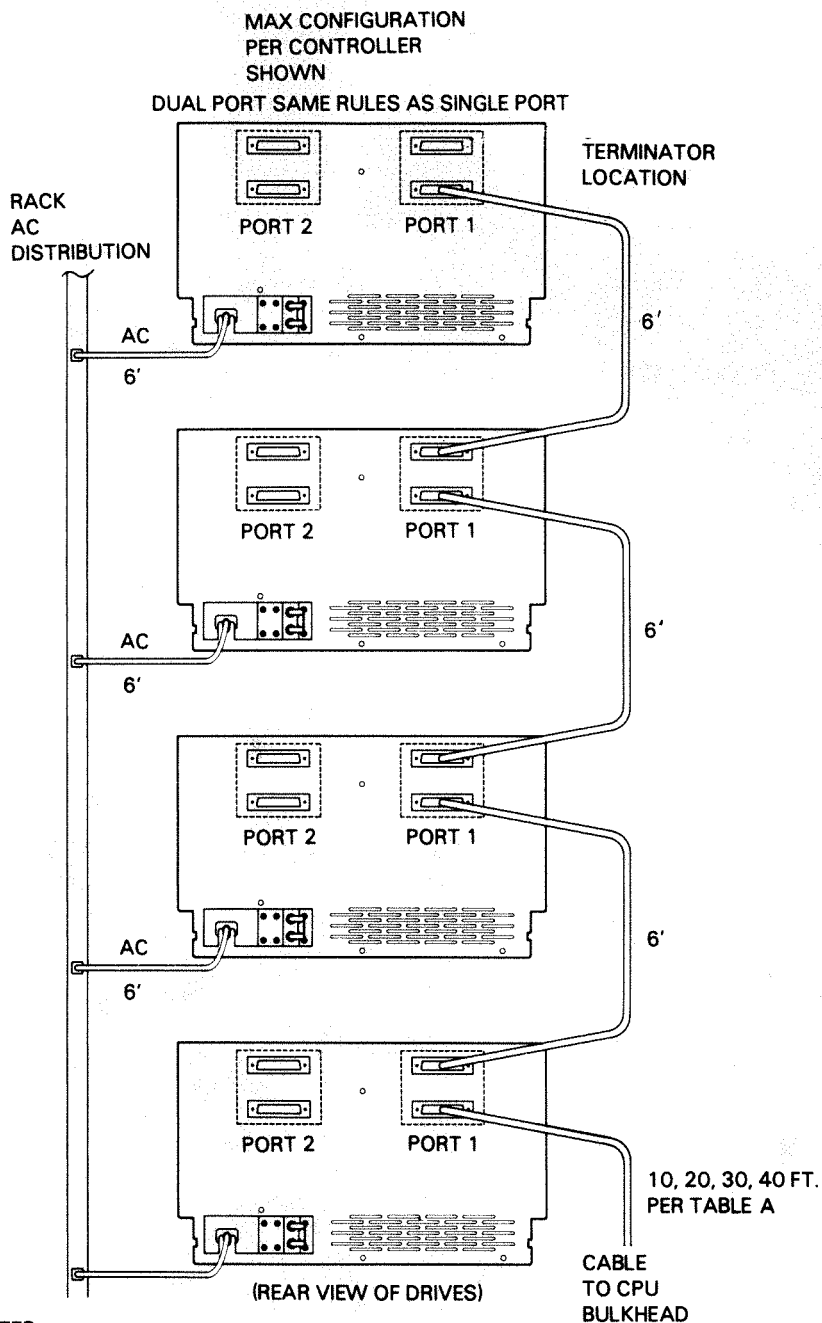

**NOTES:**

FOR FEWER THAN 4 DRIVES PER CONTROLLER, ELIMINATE 6' CHAINING CABLE(S) AND LOCATE TERMINATOR IN TOP POSITION OF THE TOP DRIVE.

6' ALLOWS MIDPOINT TO BE TIED TO FRAME FOR DRESSING, AND ANY UNIT IS ALLOWED TO BE EXTENDED ON ITS SLIDES.

CHAINED DRIVES MUST BE IN THE SAME BAY UNLESS THE INTERBAY CABLING CAN UTILIZE A 6' CABLE.

FS-07187

**Figure 6-19.** 6236 I/O Cabling and AC Power Cord Connection (Sheet 2 of 2)

015-000137



6.4.3 6237 Installation - Before the 6237 disk drive can be installed and powered-up, the following procedures must be performed on the three drives in the Meter High Cabinet.

#### WARNING

Prior to installing the disk drive(s), be sure the installation cabinet anti-tip bars are extended. Failure to do so may cause personal injury and/or equipment damage.

#### NOTE

The 6237 disk drive is shipped with the three 6236 disk drives mounted in the Meter High Cabinet. Refer to Figure 6-20 for rack mounting information.

1. Verify that the installation cabinet anti-tip bars are in the extended position (refer to Figure 6-8).
2. Depress the two tabs on the sides of the front panel assembly (on the bottom drive in the Meter High Cabinet) and remove the front panel from the chassis (refer to Figure 6-16).
3. Remove the two mounting screws securing the front cover to the Meter High Cabinet (to gain access to the drive) (refer to Figure 6-16).
4. Slide the drive forward and out of the Meter High Cabinet.
5. Remove the three shipping pre-load bolts and store them on the clip on the front panel. Install the plugs in two places as shown in Figure 6-11.
6. Remove the carriage shipping lock and store it in the fuse clip in the front panel (refer to Figure 6-11).
7. Install the linear motor sealing screw, install the hole plug in front cover as shown in Figure 6-11.
8. Set the write protect switch on the read/write PCB to the Write Enable position and the disable switch on the power amplifier PCB to the Normal Operation position (refer to Figure 6-15). (Gain access through the holes in the top cover.)
9. Set front panel switches SW3 and SW4 to the OFF position (normal operating position). Set SW1 and SW2 to the appropriate disk drive unit number 0 to 2 (refer to Figure 6-17). (Top drive unit #0, middle drive unit #1, bottom drive unit #2).

10. Remove the rear cover of the disk drive to gain access to the power supply assembly (refer to Figure 6-13). Verify that the power supply is jumpered in the correct voltage configuration (refer to Figure 6-14).
11. Replace the power supply protective cover (if removed), install the rear cover.
12. Carefully slide the drive back into the Meter High Cabinet until the front cover mounting brackets are flush with the installation cabinet rack mount supports.

#### CAUTION

Damage to the drive will occur if the disk drive is powered-up without the coarse air filter installed on the front cover.

13. Verify that the coarse air filter is present and positioned correctly on the front panel. Install the front panel.
  14. Repeat steps #2 through #13 for the middle drive, and for the top drive. Assign unit number 0 for the top drive, unit number 1 for the middle drive, and unit number 2 for the bottom drive.
- 6.4.3.1 I/O Cabling and AC Power Cord Connection - The controller PCB will support up to four 6236 disk drives. A terminator must be installed in the last drive in the daisy chain (refer to Figure 6-21).

Data General Corporation (DGC) has prepared this manual for use by DGC personnel and customers as a guide to the proper installation, operation, and maintenance of DGC equipment and software. The drawings and specifications contained herein are the property of DGC and shall neither be reproduced in whole or in part without DGC's prior written approval nor be implied to grant any license to make, use, or sell equipment manufactured in accordance herewith.

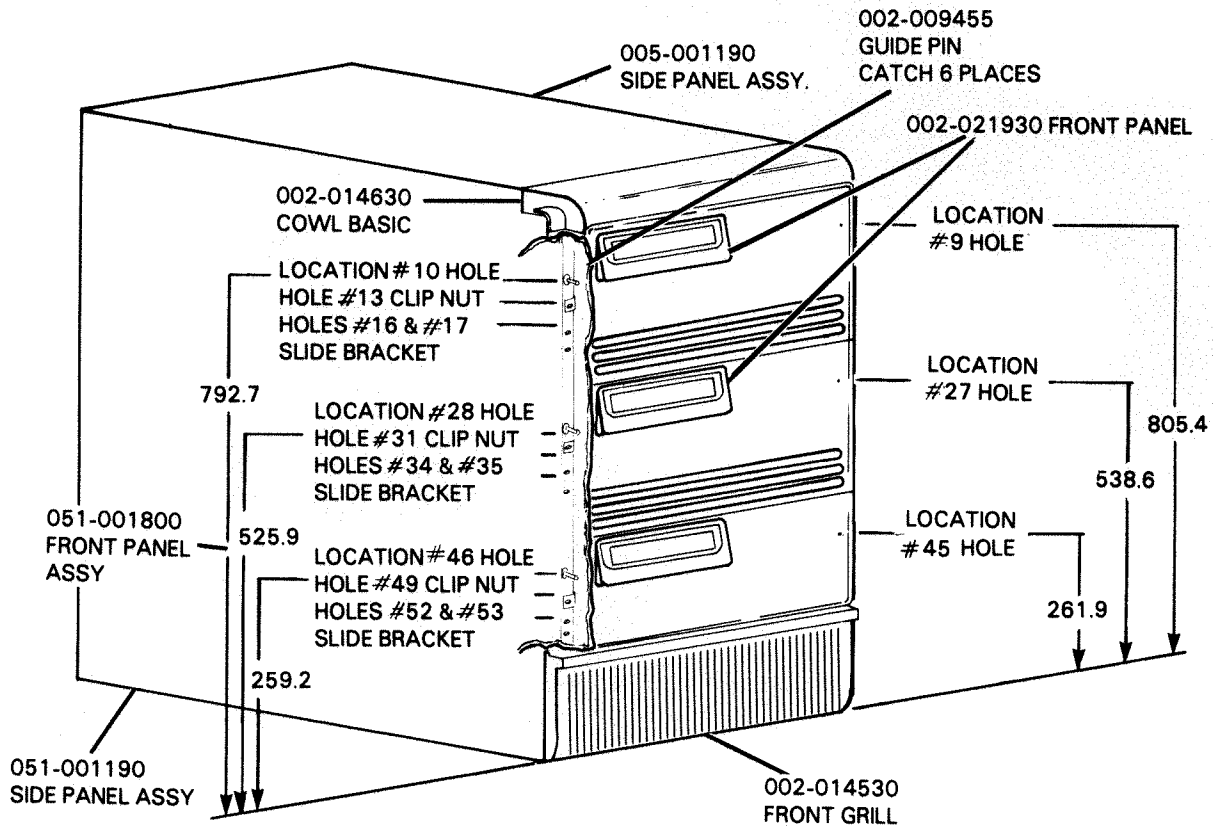

ASSEMBLY GUIDE PIN

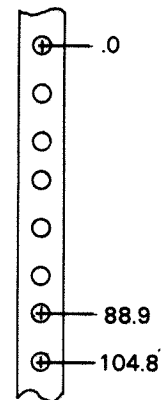

TYPICAL HOLE PATTERN FOR ASSEMBLY OF  
123-001963 SLIDE ASSY TO 002-014580  
SIDE FRAME WELDMENT

FS-07188

Figure 6-20. 6237 Rack Mounting

FS-07189

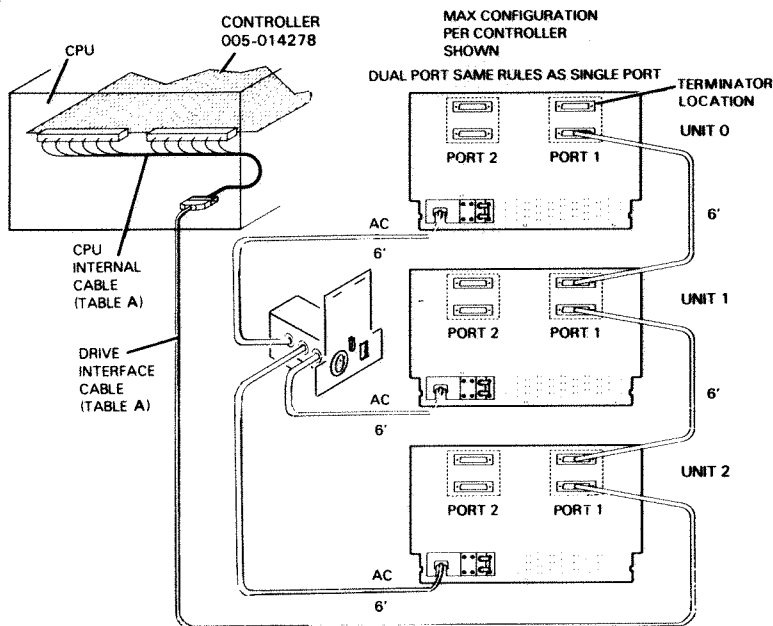

TABLE A (CPU INTERNAL & INTERFACE CABLES)

CPU DESIGNATOR	CPU TYPE	CPU INTERNAL CABLE	EXTERNAL CABLES			
			10'	20'	30'	40'
13-14	M600	005-020216	005-020298	005-020631	005-020632	005-020633
13-14	S250	005-020216	005-020298	005-020631	005-020632	005-020633
13-14	S350	005-020216	005-020298	005-020631	005-020632	005-020633
13-14	MV8000	005-020216	005-020298	005-020631	005-020632	005-020633
22-22	MV6000	005-020216	005-020298	005-020631	005-020632	005-020633
22-22	S140	005-020216	005-020298	005-020631	005-020632	005-020633
70-89	S280	005-020104	005-018480	005-021154	005-020629	005-020630
70-89	MV4000	005-020104	005-018480	005-021154	005-020629	005-020630
70-89	MV10000	005-020104	005-018480	005-021154	005-020629	005-020630
70-89	MV8000 II	005-020104	005-018480	005-021154	005-020629	005-020630
ALL CPUS		6' DRIVE DAISY CHAIN CABLE - 005-020186 DRIVE TERMINATOR - 005-020105				

TABLE B AC LINE CORD FOR INTERNAL ARGUS DRIVE

100V/50 HZ	} 109-000719
100V/60 HZ	
120V/60 HZ	
220V/50 HZ	} 109-000618
240V/50 HZ	

TABLE C (EXTERNAL MATING CONNECTOR TYPE)

	2 PH	3 PH
WALL (NEMA)	L14-30R	L21-30R
DROP (NEMA)	L14-30P	L21-30P

Figure 6-21. 6237 I/O Cabling and AC Power Cord Connection

## 6.5 POWER-UP/DOWN PROCEDURES

The following paragraphs describe the power-up and power-down procedures for the disk drive.

### NOTE

Refer to Section 2 for detailed information on disk drive operating procedures.

#### 6.5.1 Power-Up Procedure - The power-up procedure is as follows:

1. Plug the drive into the ac power source.
2. Set the circuit breaker(s) in the ON position (refer to Figure 6-22).
3. Set the power ON/OFF switch in the ON position.

#### 6.5.2 Power-Down Procedure - The power-down procedure is as follows:

1. Set the power ON/OFF switch in the OFF position.
2. Set the circuit breakers in the OFF position.

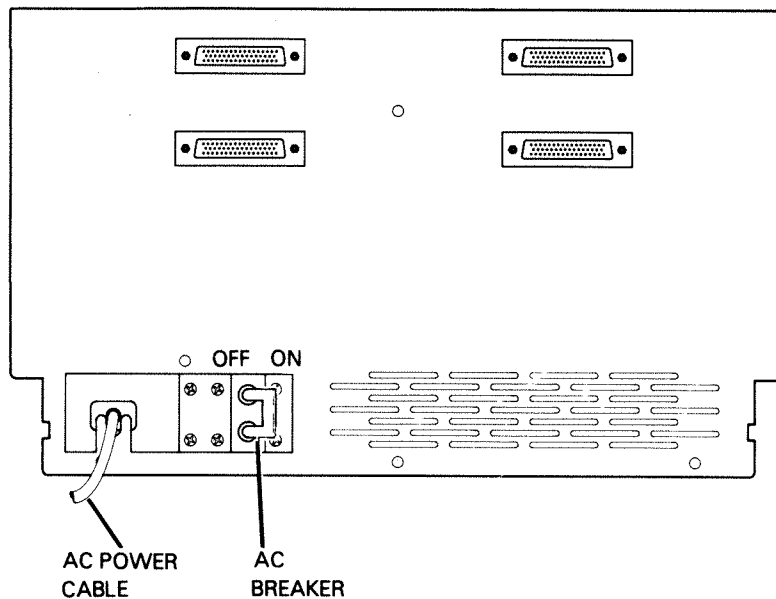

FS-07190

Figure 6-22. Circuit Breaker

## 5.6 SUBSYSTEM VERIFICATION

The procedure for 6236/6237 subsystem verification is as follows:

1. Power-up the drive. The drive will perform a power-up test (refer to Section 2). The drive will come READY. (If the drive does not come READY, refer to Section 4 and troubleshoot the problem.)
2. Load either UDKP or UDKV RELI (refer to Section 4).
3. Run one error free pass of SA505 (RUNALL). (If a 6236/6237 disk drive subsystem error condition exists, refer to Section 4 and troubleshoot the problem.)

## 5.7 SUBSYSTEM REMOVAL

### CAUTION

Do not attempt to move the disk drive until the following steps are performed. Failure to do so will result in equipment damage.

1. Remove power from drive and front panel.
2. Remove hole plug (123-002012) and install carriage shipping lock. Replace plug.
3. Remove (123-001975) plug (two places) and install shipping pre-load bolts (three places). Store plugs in storage clip.
4. Drive should be transported only in approved shipping package.

To remove the disk drive subsystem, reverse the steps outlined in this procedure.



## FIELD ENGINEERING TECHNICAL PUBLICATIONS COMMENT FORM

Maintenance Service Guide  
Models 6236/6237  
DISK DRIVE SUBSYSTEM  
(Doc. No. 015-000137)

We would appreciate your taking the time to fill out this form. Your answers and comments will help us improve the quality and usefulness of our publications.

YES NO

Was the manual easy to use? If not, please explain why.

Did the manual tell you everything you needed to know? What additional information would you have liked?

Was the information accurate? If not, please tell us what the inaccuracies were.

TAPE

FOLD DOWN

FIRST

FOLD DOWN



NO POSTAGE  
NECESSARY  
IF MAILED  
IN THE  
UNITED STATES

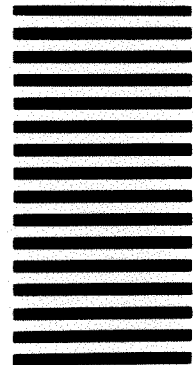

**BUSINESS REPLY MAIL**

FIRST CLASS

PERMIT NO. 26

SOUTHBORO, MASS. 01772

Postage will be paid by addressee.

**Data General Service, Inc.**

A Subsidiary of Data General Corporation

50 Maple Street  
Milford, MA. 01757  
M.S. M234

**ATTENTION: Field Engineering Technical Publications Manager**

FOLD UP

SECOND

FOLD UP

TAPE