

**HP 250
Model 20 and 25
Site Preparation
and
Installation Guide**

HP 250

**HP 250
Model 20 and 25
Site Preparation
and
Installation Guide**

Manual Part No. 45260-90005



8010 Foothills Blvd., Roseville, CA 95678
Printed in U.S.A., January, 1984

FEDERAL COMMUNICATION COMMISSION RADIO
FREQUENCY INTERFERENCE STATEMENT

The United States Federal Communications Commission (in Subpart J, of Part 15, Docket 20780) has specified that the following notice be brought to the attention of the users of this product:

"Warning: This equipment generates, uses, and can radiate radio frequency energy and if not installed and used in accordance with the instructions manual, may cause interference to radio communications. It has been tested for compliance with the limits for Class A computing devices pursuant to Subpart J of Part 15 of FCC Rules, which are designed to provide reasonable protection against such interference. Operation of this equipment in a residential area is likely to cause interference in which case the user at his own expense will be required to take whatever measures may be required to correct the interference."

"This product has been tested and licensed by the Fernmeldetechnisches Zentralamt (FTZ) for use in West Germany. Included with the system is a registration postcard to be completed and mailed for all German installations."

NOTICE

The information contained in this document is subject to change without notice.

HEWLETT-PACKARD MAKES NO WARRANTY OF ANY KIND WITH REGARD TO THIS MATERIAL, INCLUDING, BUT NOT LIMITED TO, THE IMPLIED WARRANTIES OF MERCHANTABILITY AND FITNESS FOR A PARTICULAR PURPOSE. Hewlett-Packard shall not be liable for errors contained herein or for incidental or consequential damages in connection with the furnishing, performance or use of this material.

Hewlett-Packard assumes no responsibility for the use or reliability of its software on equipment that is not furnished by Hewlett-Packard.

This document contains proprietary information which is protected by copyright. All rights are reserved. No part of this document may be photocopied, reproduced or translated to another program language without the prior written consent of Hewlett-Packard Company.

PRINTING HISTORY

New editions are complete revisions of the manual. Update packages, which are issued between editions, contain additional and replacement pages to be merged into the manual by the customer. The date on the title page and back cover of the manual changes only when a new edition is published. When an edition is reprinted, all the prior updates to the edition are incorporated. No information is incorporated into a reprinting unless it appears as a prior update. The edition does not change.

First Edition.....	Mar 1982
Second Edition.....	Jan 1983
Third Edition.....	Jan 1984

Table of Contents

Chapter 1: Introduction

Manual Organization.....	1-2
--------------------------	-----

Chapter 2: Site Preparation

Introduction.....	2-1
Preparing for Installation.....	2-1
Selection Of Principal Operator.....	2-2
Preparation Checklist.....	2-2
Where Do I Go For Help?.....	2-3
HP People Who Can Help.....	2-3
Third Party (OEM) People Who Can Help.....	2-3
Space and Environment Planning.....	2-4
Floor Plan.....	2-4
Atmospheric Considerations.....	2-4
Flammable Materials.....	2-4
Airborne Contaminants.....	2-4
Temperature and Humidity.....	2-5
System Size and Weight.....	2-8
Electrical Specifications.....	2-9
HP 250 Power Requirements.....	2-9
Line Voltage.....	2-9
Frequency.....	2-9
Safety Ground.....	2-9
Dedicated Circuits.....	2-11
Power Line Transients.....	2-11
Neutral Ground and Ground-Ground Voltages.....	2-11
Sources of Electrical Interference.....	2-11
Wall Outlets.....	2-11
Lightning.....	2-11
Radiated Interference.....	2-12
Connection Cables and Power Cords.....	2-12
Data Communications.....	2-12
Direct Connections.....	2-13
Local Laws.....	2-13
Providing Other Necessities.....	2-13
Media Storage.....	2-13
Protection of Valuable Records.....	2-14
Computer Supplies.....	2-14
Telephone.....	2-14

Chapter 3: Model 20 and 25 Installation

Introduction.....	3-1
Installing the Mainframe.....	3-3
Assembling and Installing the Workstation.....	3-5
Setting Workstation Configuration.....	3-7
Loading from a Flexible Disc Drive.....	3-10
HP 2631B Printer Installation.....	3-12
HP 2601A Printer Installation.....	3-18
HP 2602A Printer Installation.....	3-22
HP 82905B Printer Installation.....	3-26
HP 2932A, 2933A, and 2934A Printer Installation.....	3-27A
HP 2563A Printer Installation.....	3-27B
HP 2687A Page Printer Installation.....	3-27D
HP 2687A Page Printer Installation.....	3-27D
CONFIGuring Printers.....	3-28
Printer System Test.....	3-30
Installing Plotters.....	3-32
Setting Up the HP 7220C/T and HP 7221C/T Plotters.....	3-33
Setting Up the HP 7225 Plotter.....	3-40
HP 7470A Plotter Installation	3-47
CONFIGuring Plotters	3-49
Additional Workstations	3-51
HP 3075A, 3076A, and 3077A Data Capture Terminal Installation.....	3-52
HP 3081A Data Capture Terminal Installation	3-52B
HP 39800A Bar Code Reader Installation	3-52D
After All Peripherals are Installed	3-52G

Appendix A -- Space Planning Kit

Appendix B -- Electrical Specifications

Model 20 and 25 Power Specifications.....	B-1
Direct Connections.....	B-3
Approvals.....	B-7

Appendix C -- Customer Engineer Locations

CHAPTER 1

Introduction

This manual explains how to prepare the computer site and install the HP 250 Models 20 and 25. Models 20 and 25 can include the following:

HP 250 Model 20 Mainframe (Central Processor Unit,
Flexible Disc Drive, and 5 Mb. Disc)

HP 250 Model 25 Mainframe (Central Processor Unit,
Flexible Disc Drive, and 10 Mb. Disc)

*HP 2622D Workstation (Display and Keyboard)

HP 2601A Printer

HP 2602A Printer

HP 2631B Printer

HP 2563A Printer

HP 2687A Printer

HP 2932A Printer

HP 2933A Printer

HP 2934A Printer

HP 82905B Printer

HP 7220C Plotter

HP 7220T Plotter (Automatic Paper Advance)

HP 7221C Plotter

HP 7221T Plotter (Automatic Paper Advance)

HP 7225 Plotter

HP 7470A Plotter

HP 3075A Data Capture Terminal

HP 3076A Data Capture Terminal

HP 3077A Data Capture Terminal

HP 3081A Data Capture Terminal with

HP 92922A 4-Channel RS-232-C Adapter

HP 39800A Bar Code Reader

- * Use a current loop to connect additional workstations or the HP 2631B printer to the system at distances greater than 50 feet (15 meters). The main workstation must be within 50 feet of the system, direct-connected with an RS-232-C cable, with both the main workstation and system accessible by an HP Customer Engineer or System Engineer for service.

This manual covers site preparation and installation of these components. Consult accompanying manuals for further information.

The instructions in this manual are written for the first-time user. No special tools, or knowledge of computers or electronics, is required of you. Appendix B contains all the technical information required by your electrician.

If the guidelines in this manual are followed correctly, your HP 250 will operate reliably, and you will qualify for an HP service contract to provide Customer and System Engineer consultations and repair visits.

Introduction

If you decide to add any component to your system which is not covered in this manual, consult the manual "Preparing for Your HP 250," (manual part number 45260-90040) and your HP Customer Engineer (see Appendix C) for additional grounding requirements.

Manual Organization

The remainder of this Guide consists of two chapters:

Chapter 2 Model 20/25 Site Preparation

Chapter 3 Model 20/25 Installation.

There are three appendixes following the chapters:

Appendix A Space Planning Kit -- consists of scale drawings of the system components and a grid (at the same scale) to help you plan your computer site layout.

Appendix B Electrical Specifications -- contains the technical specifications your electrician will need to assist you in site preparation.

Appendix C Customer Engineer Locations (Service Responsible Offices) -- lists the location of the HP 250 Customer Engineer nearest you.

CHAPTER 2

Site Preparation

Introduction

This chapter helps you plan and prepare for installation of the HP 250 Model 20 or 25. The specifications help you decide where to put the system, how to prepare the environment, what must be ready when the system arrives, and what you must do for receiving and unpacking.

This chapter simplifies site preparation by explaining the specifications to the first-time computer user.

The technical specifications required by your electrician are in Appendix B; explanations for the specifications are in this chapter. Your electrician should read both.

You are responsible for scheduling, planning, and preparing a suitable site for the HP 250 Model 20 or 25 Computer System. Hewlett-Packard has made an intensive design effort to make the HP 250 System adaptable to the typical office environment. If your site is unusual, HP or your Third Party supplier may recommend that you purchase HP's Site Planning Service.

This chapter is a reference for site preparation of the HP 250 Models 20 and 25. Various planning aids are provided to smooth your planning and installation. The major parts of the chapter are:

- * "Space and Environment Planning" includes floor plans, atmospheric considerations, temperature and humidity requirements, and system dimensions.
- * "Electrical Specifications" covers power requirements, communication configurations, connecting cables, lightning protection, and radiated interference.
- * "Providing Other Necessities" lists additional considerations for computer operation, such as media storage, computer supplies, and phone access.

Preparing for Installation

Although you are responsible for providing suitable space and environment for the HP 250, no extensive preparation should be required. This chapter specifies all requirements.

Selection Of Principal Operator

Select someone to be the Principal Operator. This person is responsible for site preparation and system installation, operation, and maintenance. Initially, the Principal Operator is responsible for monitoring site preparation schedules, ordering computer supplies, and scheduling training for system users. In the process, the Principal Operator should become familiar with the HP 250 System and be ready to start its operation when the system is installed.

Preparation Checklist

1. Select the location for your HP 250 Computer System.
2. Have an electrician check the capacity and location of your electrical wiring. Install extra outlets for other equipment.
3. Be sure the wall outlets are grounded.
4. Select a Principal Operator to be responsible for the successful site preparation, installation, and operation of your HP 250 system.
5. Check the temperature and humidity of the computer site. Install climate control equipment if necessary.
6. Plan the physical arrangement of the system and furniture. (Appendix A)
7. Order consumable supplies, including flexible discs, printer paper and ribbon, and plotter paper and pens. Set up a storage area.
8. If the site is carpeted, take measures necessary to reduce static. This is explained later under "Temperature and Humidity".

Where Do I Go for Help?

HP People Who Can Help

To assist you in understanding the Hewlett-Packard organization, here is a list of HP service personnel. Each member of the HP team is well-trained and dedicated to maximizing your benefit from the HP 250.

Sales Representative -- is your primary contact. Your Sales Rep coordinates HP resources to ensure on-time delivery and installation of the system. Later, call the Sales Rep to arrange staff training or additional system peripherals.

Customer Engineer (CE) -- is the expert in computer and peripheral equipment service. The CE has the tools, parts, and skills to maintain your HP 250. If you purchase an HP Maintenance Agreement, the CE will provide hardware maintenance, repair, and problem diagnosis.

Systems Engineer (SE) -- is the technical specialist in HP 250 subsystems and the HP 250 programming language. Your SE offers training courses and technical consulting on the programming language, utility programs, data base management, and system performance. If you sign up for the HP 250 Customer Support Service plan (CSS), the SE will provide software consulting and problem diagnosis.

Third Party (OEM) People Who Can Help

Original Equipment Manufacturer (OEM) or System House -- If you have purchased an HP 250 computer system and/or applications software from a third party, that party will provide consultation services on system operation and applications software (programs). In this situation, a Maintenance Agreement for hardware and CSS for standard HP software is available from Hewlett-Packard.

Space and Environment Planning

Floor Plan

The location you select should satisfy immediate and future requirements. Once the site has been prepared, the cables will probably restrict future moving. Select a spacious site so you can add more equipment as your needs expand.

The "Space Planning Kit", located in Appendix A, helps you plan the physical layout of your HP 250 site. The kit contains scaled diagrams of HP 250 equipment and a scaled floor plan.

Use the space planning kit to ensure you have sufficient room for operating, servicing, and ventilating the equipment. One meter (3 feet) of free space around the computer should be sufficient.

If you plan to store the computer in a smaller space, like between desks or under a counter, be sure to have enough cable to roll the system into the operating area.

Atmospheric Considerations

Flammable Materials

Fundamental safety precautions should be taken. Minimize potential sources of damage. Do not install the HP 250 where there is a fire hazard from flammable gasses, liquids, or dust.

Airborne Contaminants

Airborne particles of a certain size or hardness may scratch the coating on the flexible disc or disc drive head, causing premature disc wear and/or data errors.

The most common contaminants are dust, smoke, ashes, eraser crumbs, salty air, cookie crumbs, and other food. Solvent vapors, such as those from liquid spirit duplicating equipment, wet process copiers, and volatile liquids, can soften disc coatings over a period of time. To prevent excessive wear, avoid bringing these contaminants into contact with your computer.

Temperature and Humidity

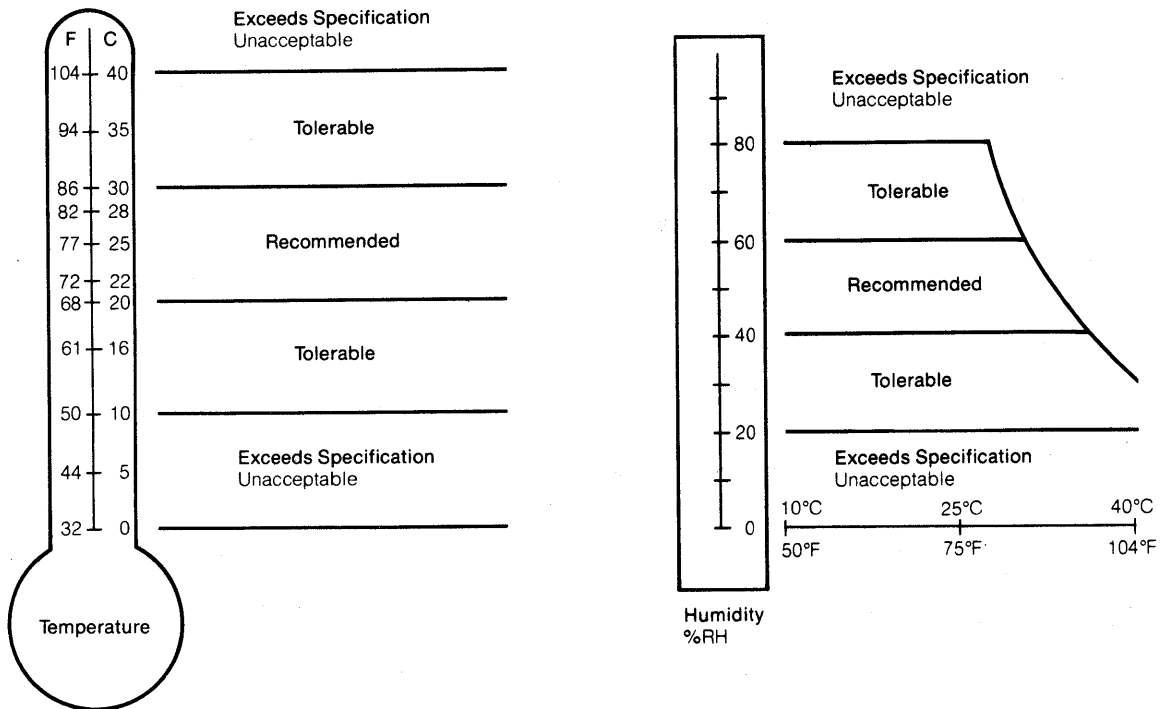

Figure 2-2. Temperature and Humidity Requirements

Higher operating temperatures considerably increase the failure rate of electronic circuitry. At 32 degrees Celcius (90 degrees Fahrenheit, HP statistics show a 25% higher failure rate of components than operating at 25 degrees Celcius (77 Fahrenheit).

If you intend to use your HP 250 on weekends, when the building temperature might waver, check the temperature and humidity of the site before operating the equipment. Auxiliary air conditioning (or heating) might be required to prevent damage to the equipment. If necessary, use an inexpensive thermometer and humidity gauge to monitor your site.

The HP 250 Computer System is air-cooled. Fans circulate cool air through the system and discharge warmer air into the room. Each component must have 1 meter (3 ft) of free space to allow warm air to dissipate properly. Table 2-2 helps you calculate the total heat output of your particular system configuration. Use your calculations of heat output (Table 2-2) and Figure 2-3, "Room Temperature Rise" to compute the rise in room temperature once your computer is installed.

(Readings for existing temperatures should be taken near the floor in the approximate area where the equipment will be located.)

Site Preparation

Table 2-2. Calculation of Heat Output by Machine Type

HP 250 MACHINE TYPE	WATTS	BTU/HR	MULTIPLY BY NUMBER OF MACHINES	EQUALS TOTAL HEAT OUTPUT PER MACHINE TYPE
HP 250 20/25 SYSTEM UNIT (INC. 2622D)	275	940		
2601A PRINTER	120	410		
2602A PRINTER	90	315		
2631B PRINTER	150	510		
2563A PRINTER	230	784		
2687A PRINTER	840	2684		
2932A PRINTER	225	768		
2933A PRINTER	225	768		
2934A PRINTER	225	768		
82905A PRINTER	100	341		
2622D WORKSTATION	65	220		
7220C/T PLOTTER	100	341		
7221C/T PLOTTER	100	341		
7225B PLOTTER	70	240		
7470A PLOTTER	25	85		
307X DATA CAPTURE TERMINALS	90	307		
3081A DATA CAPTURE TERMINAL WITH 92922A ADAPTER	45	154		
39800A BAR CODE READER	25	85		
Your HP250 System Heat Dissipation Total =				

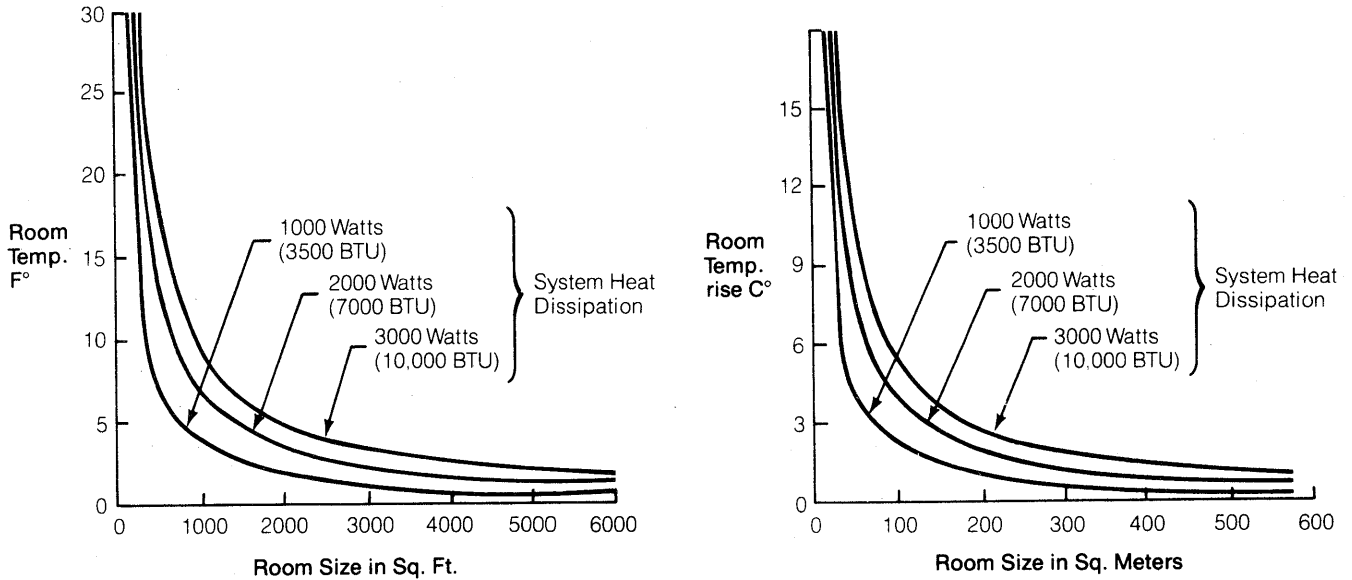

Figure 2-3. Room Temperature Rise

NOTE: No noticeable temperature rise occurs in rooms larger than 300 square meters (3000 sq. feet).

Avoid extremes in relative humidity. High humidity can cause malfunctions in the disc drive or improper feeding of printer paper, while low humidity aggravates static electricity problems and causes flexible disc wear.

Especially during dry and cold weather, carpeting is a source of static electricity. Ways to reduce static electricity include:

- * Use of a room humidifier.
- * Use of grounded floor mats in front of the system.
- * Use of anti-static spray on the carpet. Spray is not recommended because it can seep into the system and coat the circuitry. If spray is used, turn off and cover the system before applying it.

System Size and Weight

Table 2-3 shows the weights of all available system components. Use the crated weights and dimensions to determine where you will uncrate and transport the components in the building. The weight column is used to determine floor loading on the site that you have selected.

Table 2-3. System Component Shipping Weights and Dimensions

COMPONENT	WEIGHT	CRATED DIMENSIONS			
		CRATED WEIGHT	HEIGHT	WIDTH	DEPTH
HP 250 MODEL 20 OR 25 MAINFRAME	63 kg (139 lb)	90 kg (198 lb)	889 mm (35 in.)	1016 mm (40 in.)	610 mm (24 in.)
2601A PRINTER	27 kg (60 lb)	33 kg (73 lb)	737 mm (29 in.)	737 mm (29 in.)	457 mm (18 in.)
2602A PRINTER	17 kg (37 lb)	23 kg (50 lb)	686 mm (27 in.)	660 mm (26 in.)	356 mm (14 in.)
2631B PRINTER	23 kg (51 lb)	30 kg (66 lb)	787 mm (31 in.)	635 mm (25 in.)	1016 mm (40 in.)
2563A PRINTER	34 kg (75 lb)	38 kg (84 lb)	274 mm (10.75 in.)	600 mm (23.6 in.)	450 mm (17.75 in.)
2687A PRINTER	68 kg (150 lb)	72 kg (159 lb)	305 mm (12 in.)	510 mm (20 in.)	499 mm (19.6 in.)
2932A/ 2933A/ 2934A PRINTERS	20.4 kg (45 lb)	23.2 kg (51 lb)	185 mm (7.28 in.)	600 mm (23.9 in.)	365 mm (14.3 in.)
82095B PRINTER	5.5 kg (12 lb)	8.2 kg (18 lb)	533 mm (21 in.)	482 mm (19 in.)	305 mm (12 in.)
2622D WORKSTATION	23 kg (51 lb)	30 kg (66 lb)	533 mm (21 in.)	610 mm (24 in.)	610 mm (24 in.)
7220 C/T PLOTTERS	29 kg (64 lb)	30 kg (66 lb)	787 mm (31 in.)	660 mm (26 in.)	432 mm (17 in.)
7221 C/T PLOTTERS	24 kg (53 lb)	25 kg (55 lb)	711 mm (28 in.)	660 mm (26 in.)	406 mm (16 in.)
7225B PLOTTER	12 kg (26 lb)	14 kg (31 lb)	559 mm (22 in.)	533 mm (21 in.)	330 mm (13 in.)
7470A PLOTTER	6.1 kg (13.5 lb)	12 .6 kg (28 lb)	1295 mm (51 in.)	1219 mm (48 in.)	838 mm (33 in.)
3075A DATA CAPTURE TERMINAL	6.6 kg (14.4 lb)	8.7 kg (19.1 lb)	260 mm (10.2 in.)	275 mm (10.8 in.)	420 mm (16.6 in.)
3076A/3077A DATA CAPTURE TERMINAL	10.6 kg (23.5 lb)	12.7 kg (27.9 lb)	550 mm (21.7 in.)	440 mm (17.3 in.)	190 mm (7.5 in.)
3081A DATA CAPTURE TERMINAL	1.5 kg (3.3 lb)	2 kg (4 lb)	300 mm (12 in.)	300 mm (7 in.)	45 mm (1.8 in.)
92922A 4-CHANNEL ADAPTER	5 kg (11 lb)	6 kg (13.2 lb)	84 mm (3.4 in.)	210 mm (8.4 in.)	350 mm (14 in.)
39800A BAR CODE READER	2 kg (4.4 lb)	3 kg (6.6 lb)	71 mm (2.8 in.)	260 mm (10.25 in.)	189 mm (7.4 in.)

Electrical Specifications

HP 250 Power Requirements

Your HP 250 has specific electrical specifications. Have your electrician read Appendix B, check the site you have selected, and make adjustments as necessary.

Call your electrician if you need. . .

- * Line voltages measured.
- * Safety connections verified.
- * Advice on correct circuit breakers and wire sizes.
- * Neutral-ground and ground-ground voltages measured.

Line voltage

The exact AC voltage at the wall outlet depends on the electric Company and your building power distribution. The electric company provides voltage within a certain range up to your building. Any voltage drop inside a building is caused by the wiring between the electric company hookup and the wall outlet.

Power voltages outside the specified operating range can cause intermittent system errors or shutdown. Low voltage is the most common power problem, and is usually caused by inadequate wiring.

Frequency

Frequency usually depends on the local electric company. Rarely, power is generated by a motor inside your building. This can cause intermittent system errors or CRT display jitter.

Safety Ground

For your protection, every wall outlet used by your system must have a safety ground. If you decide to add any component to your system which is not covered in this manual, consult "Preparing for Your HP 250," (manual part number 45260-90040) and your HP Customer Engineer (see Appendix C) for additional grounding requirements.

The green-wire ground is connected to the metal frame of each system component to protect an operator against equipment malfunction, and make the equipment resistant to a catastrophic event such as a lightning strike. To preserve this protection, do not plug the system into wall outlets that have no ground connections. Be sure that the green ground wire is connected from the outlet to the distribution sub-panel where the circuit breaker is installed.

Site Preparation

Figure 2-4 lists the three-conductor grounded power cords offered with the HP 250 and components.

	<p>U.S.A., Canada, Japan, Mexico, Philippines, Taiwan Standard HP Part Number: 8120-2371 Length: 2.29m (7.5 ft) Rating: 125V, 13a, single phase NEMA5-15P</p>		<p>U.S.A., Canada, Japan, Mexico, Philippines, Taiwan Option 904 HP Part Number: 8120-0698 Length: 2.29m (7.5 ft) Rating: 250V, 6a, single phase NEMA6-15P</p>
	<p>Great Britain, Cyprus, Nigeria, Rhodesia, Singapore Option 900 HP Part Number: 31000-60057 Length: 2.29m (7.5 ft) Rating: 250V, 10a, single phase BS 1363A</p>		<p>Switzerland Option 906 HP Part Number: 8120-2104 Length: 2m (6.5 ft) Rating: 250V, 6a, single phase SEV 1011</p>
	<p>Australia, New Zealand Option 901 HP Part Number: 8120-1369 Length: 2m (6.5 ft) Rating: 250V, 6a, single phase AS C112</p>		<p>Denmark Option 912 HP Part Number: 8120-2956 Length: 2m (6.5 ft) Rating: 250V, 6a, single phase DHCR 107</p>
	<p>Belgium, Italy, France, Spain, Greece, Austria, Finland, Germany, Netherlands, Norway, Sweden, Saudi Arabia, United Arab Republic Option 902 HP Part Number: 8120-2857 Length: 2m (6.5 ft) Rating: 250V, 6a, single phase CEE7-VII</p>		

Figure 2-4 Power Cords (US and International)

Dedicated Circuits

Separate circuit breakers for the system are suggested, but not required. Separate circuit breakers insure sufficient power to avoid data errors, and isolate the system from other faulty equipment in the room.

Circuit breakers are rated in amperes. Typical circuit breakers in the US are rated at 15 or 20 amperes. The ampere load in each circuit should allow a margin for startup and surge currents caused by the system. See Appendix B.

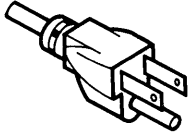
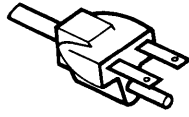
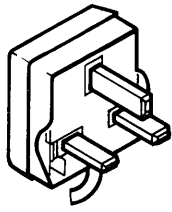
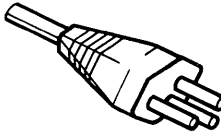
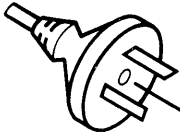
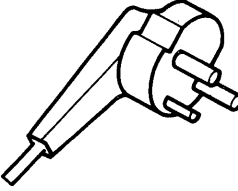
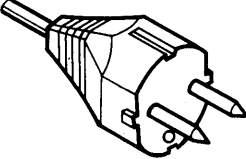
Power Line Transients

Heavy electrical loads from nearby machinery or equipment, like elevators or electric welders, can cause intermittent system errors even if that equipment is on a different circuit breaker. For those conditions, you must provide a separate, completely independent circuit with isolated ground and circuit breaker coming directly from the main building power source. In cases of severe electrical noise, it may be necessary to install an isolation or power line conditioning transformer. (See "Preparing for Your HP 250," manual part no. 45260-90040.)

Neutral-ground and Ground-Ground Voltages

If the open-circuit neutral-ground (in the outlet) or ground-ground (between outlets) voltage is greater than 1V RMS, this is an indication of (1) inadequate wire size, (2) absence of ground wire, (3) poor building distribution ground, or (4) imbalance of phases on a 3-phase power distribution system. The result can be intermittent system errors or system shutdown.

Measurements also must be made with the computer system installed and running. If the voltage exceeds the specification, 4V p-p, your electrician can determine which of the four conditions is the problem, and correct the situation.

Sources of Electrical Interference

Wall Outlets

Maintenance equipment (like vacuum cleaners and floor buffers) must not be plugged into the computer system's wall outlets while the system is turned on. System errors can result.

Lightning

In some geographical areas, it is advisable to install lightning protection for personnel and the computer. The National Electrical Code, Article 280, describes the installation of lightning arrestors on power and communication

Site Preparation

lines in the United States. The principles of lightning protection and personnel safety are explained in the NFPA Handbook.

Radiated Interference

Radiated interference causes a variety of computer problems; most commonly, disc read/write errors. The most common sources of radiation are airport communications and radar, two-way radio transmitters, and TV or radio signals. Hand-held transceivers (e.g., "walkie-talkies") produce the same effect as radio stations when used near computer equipment and should therefore be prohibited from the areas in which computer equipment is operated. Additionally, do not operate a computer in the path of a microwave transmission.

HP 250 Computer Systems are designed to withstand radiation up to 0.5 volt/meter over a frequency range of 14 kHz to 1 GHz.

If you suspect a problem with radiated interference, an outside consultant can perform radiation measurements and offer advice on shielding the system from external interference. Your HP Customer Engineer (see Appendix C) may be able to recommend such a consultant.

Connection Cables and Power Cords

Data communication cables (such as RS-232) connect the HP 250 to its peripheral equipment. When planning the physical layout of your HP 250 site, consider the functional and aesthetic effects of the cables and power cords.

To avoid safety hazards and damage to cables, do not lay cables across entrances, aisles, traffic paths, or under carpeting. When planning system layout, remember that cable routing usually requires that cables be longer than the distance between components.

US and Great Britain power cords are 2.29 meters in length (7.5 ft). All other power cords are 2 meters long (6.5 ft). NEVER USE AN EXTENSION CORD FOR POWER; it can be a safety hazard.

All cables and power cords connect to the back of the equipment. Therefore, try to position the equipment along walls, near power outlets, so that cables are accessible but out of the way.

Data Communications

A direct hardwired connection is used for communication between peripheral equipment and the computer up to a distance of 15 meters (50 ft).

Direct Connections

The Asynchronous Serial Interface (ASI) (HP Product 45120B) communicates with workstations, printers, and plotters via an RS-232-C data link (cable), using a direct hardwired connection. (The EIA RS-232-C standard defines the mechanical/electrical characteristics for devices which can connect to the ASI interface.) HP supports operation of the RS-232-C data link only with the specific devices shown in Appendix B. Any changes in supported options are reported in the Configuration Guide which is available from your sales representative.

If you want to locate an HP 2622D workstation further than 15m (50 ft) from the computer, use a current loop connection for distances up to 1Km (0.6 mile). Refer to Appendix B (Figure B-3) for details on cable design and connection. Appendix B (Figure B-4) explains how to build the cable. This particular cable configuration is not supported by HP.

The current loop cable is needed at installation and should be prepared before that time.

No direct connections (RS-232 cables) are allowed between system components in different building, use a current loop instead.

Local Laws

In some localities, rules and regulations may exist for the installation of computers. It is your responsibility to comply, before delivery of the system, with mechanical codes, building codes, and electrical codes.

Providing Other Necessities

Media Storage

Store your flexible discs near the work area in a clean, dust-free environment similar to the computer environment. Extreme humidity or temperature differences between storage and working areas can cause warping of flexible discs.

If the storage and work areas cannot be kept at the same humidity and temperature, allow time for the media to reach the temperature and moisture level of the work area (typically one hour). The temperature change of flexible discs must not exceed 20 degrees Celcius per hour.

To maintain data integrity, do not place recorded media near magnetic fields, such as around motors, alternators, transformers, or other disc drives.

Protection of Valuable Records

Safety precautions are suggested because the investment in equipment and data deserves protection. Protect your business records, magnetic media, and other information that is expensive or impossible to duplicate. Duplicate records, from which necessary information can be taken in case of an accident, should be maintained. Copies of vital data should be stored away from the computer area, normally in fireproof storage. A regular updating program is necessary to maintain the value of such duplicate data storage.

Because you are making a large investment, you should investigate obtaining electronic data processing insurance. EDP insurance policies can cover both hardware and software.

Computer Supplies

The items most important to reliable operation of your system are the flexible discs. Through extensive testing, selection, and quality control, HP strives to provide high-performance discs. But HP cannot cover damage caused by disc heads when non-HP media is used.

You should order your computer supplies at the time indicated on the Pre-Installation Worksheet. Necessary items for your system include printer ribbon, printer paper, and flexible discs. For information about computer supplies, consult the HP Computer Supplies Catalog (part no. 5953-2450D), and talk to your Sales Rep.

Telephone

It is a good idea to locate a telephone with a long cord near your HP 250, so that you may easily consult with an HP Customer Engineer or System Engineer.

CHAPTER 3

Installation

Introduction

This chapter contains instructions for installing the HP 250 Model 20 and 25 and the products listed in the Introduction of this manual. Refer to the individual product manuals for more detailed information.

Install the mainframe, then the workstation, then the printers, plotters, or additional workstations.

Be sure the components you ordered are the ones you receive. Be sure the components listed on the packing slip are the ones in the box.

Read the unpacking instructions included with the packing slip.

Installation

Unpack the equipment. SAVE the documentation and packing lists. Compare the contents of each box with pictures below. Optional equipment is not included in these drawings. Note that the HP 7470A plotter, HP 2602A, HP 2932A, HP 2933A, HP 2934A, HP 2563A, HP 2687A, and HP 82905B printers, the HP 39800A bar code reader, and HP 3075A, HP 3076A, HP 3077A, and HP 3081A/HP 92922A data capture terminals do not include data communication cables.

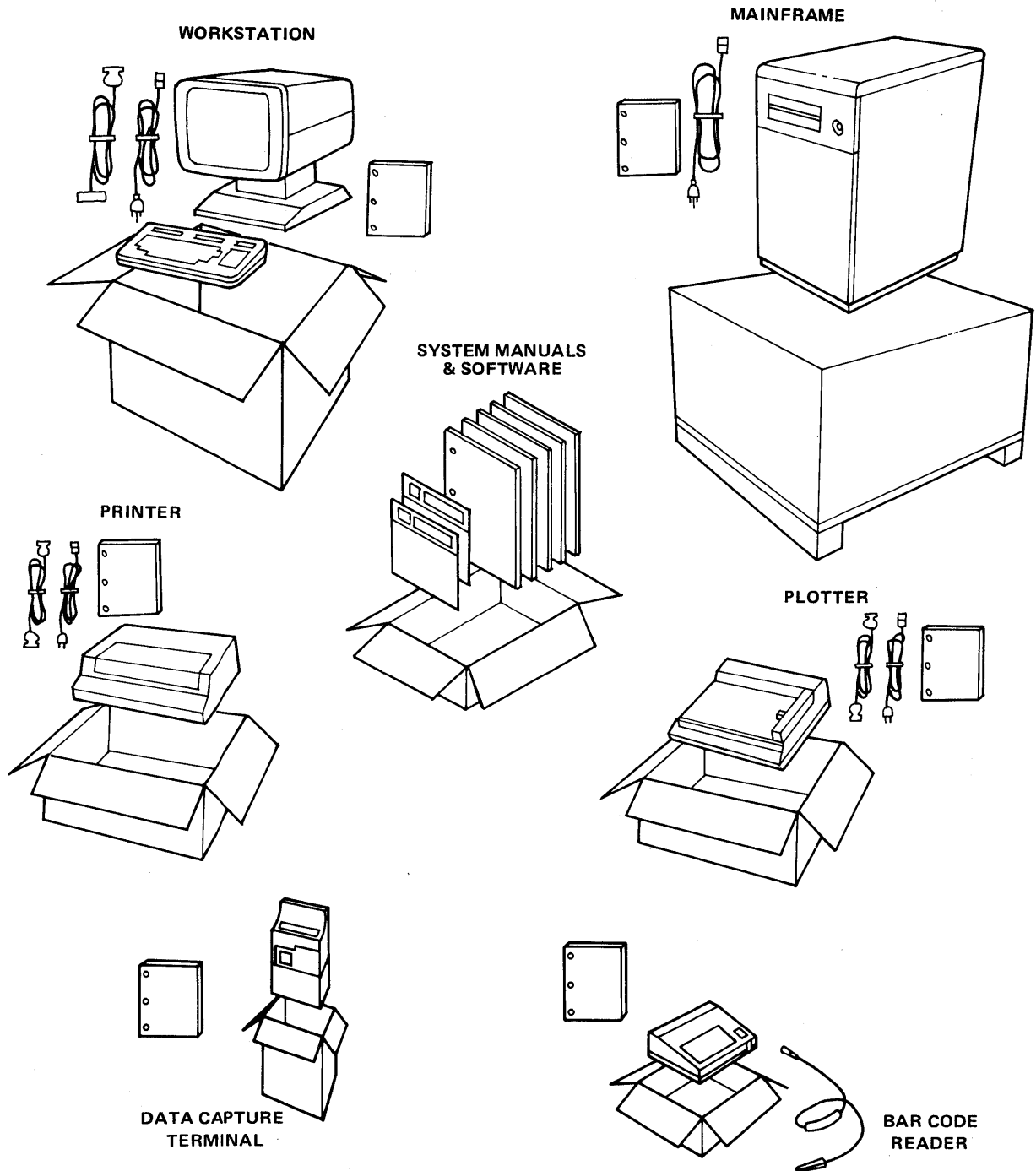

Unpacking System Components

READ THE DIRECTIONS for each part before installing it. If you have questions, call the area HP Customer Engineer (see Appendix C) BEFORE installing the part. Record your installation progress in a log book.

Installing the Mainframe

1. Remove the keys and power cord from the front panel, as pictured in the last step of the unpacking instructions. Close the front panel.
2. Set the circuit breaker switch on the mainframe's rear panel to the "off" position.

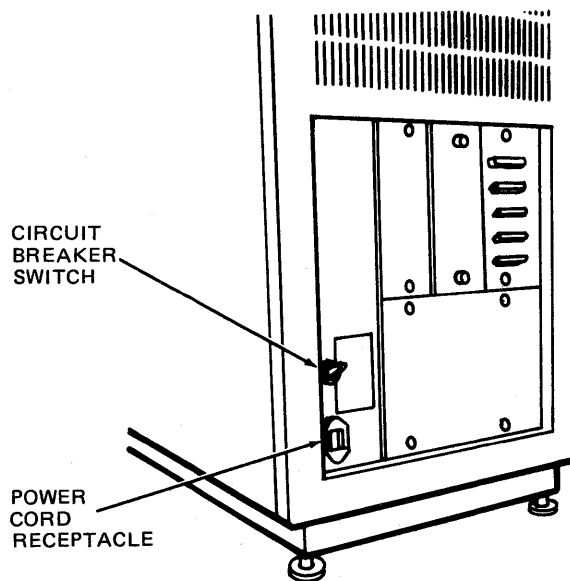

Mainframe Rear Panel

3. Insert the power cord into the receptacle on the back panel in the lower left corner.
4. Plug the power cord into the wall outlet.

Installation

5. Remove the cardboard from the flexible disc drive by first pressing the bar below the drive door, then pulling out the cardboard.

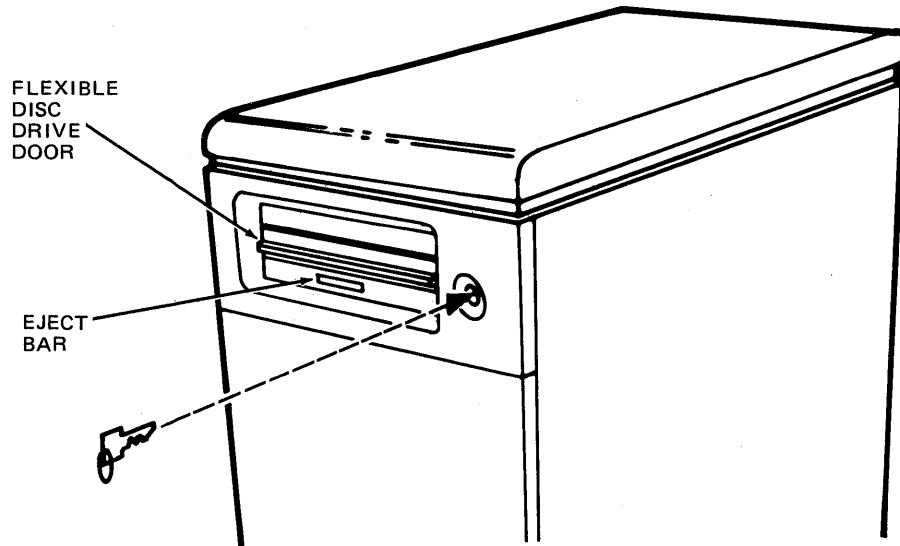

Mainframe Front Panel

6. Put the key in the lock, but DO NOT TURN THE KEY.
7. Set the circuit breaker to "on"

Assembling and Installing the Workstation

1. Place the workstation on a table or other work surface near the mainframe. Do not place it on the mainframe, any peripheral component, or box.
2. If your workstation has a thermal printer option, load the paper as shown here.

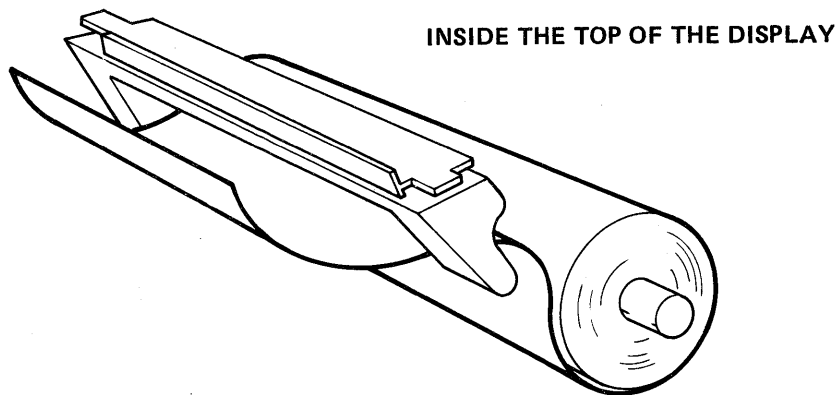

Loading Paper into the Thermal Printer

3. Plug the power cord into the receptacle on the lower left corner of the rear panel of the display unit.

Installation

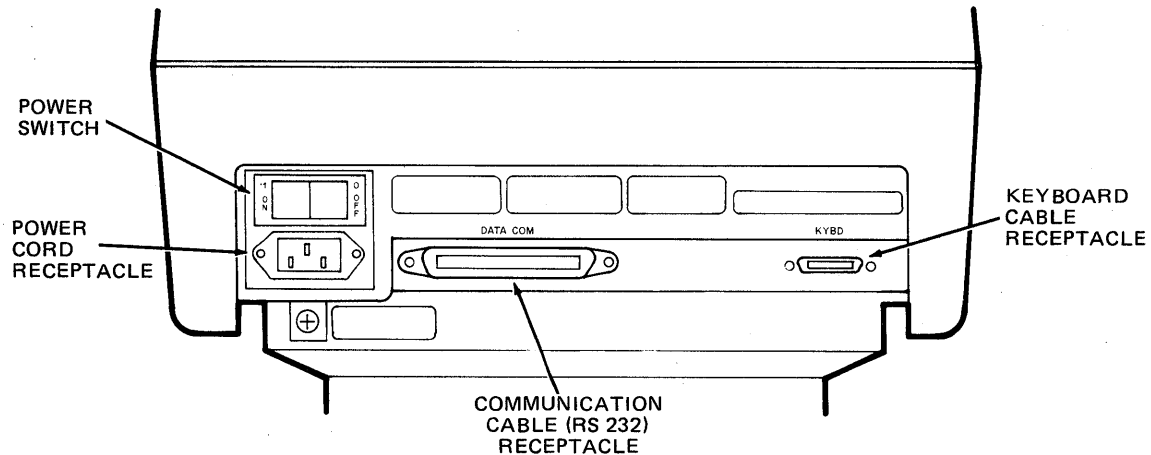

Rear Panel of the Display Unit

4. Be sure the workstation power switch (above the power cord receptacle) is in the off position.
5. Plug the power cord into the wall outlet.
6. Plug the cable connected to the keyboard into the receptacle labelled "KYBD" in the lower right corner.
7. Turn the power switch on. The workstation automatically performs a Power-On Test. When you turn the power on, listen for a single beep and watch for the words "Power On" to appear in the lower left corner of the screen. The first times you use the workstation, it might take several minutes to warm up; after regular use it will warm up in seconds. After the self-test, the workstation clears its screen.
8. After about three minutes, or after the screen warms up, press the TEST key on the upper left section of the keyboard. The "Power On" message should reappear, a display pattern should appear on the screen, and the thermal printer (if you have one) should print a test pattern.
9. After the self-test, the screen will go blank again.

Setting Workstation Configuration

In this section, you will use the keys highlighted below to configure the workstation.

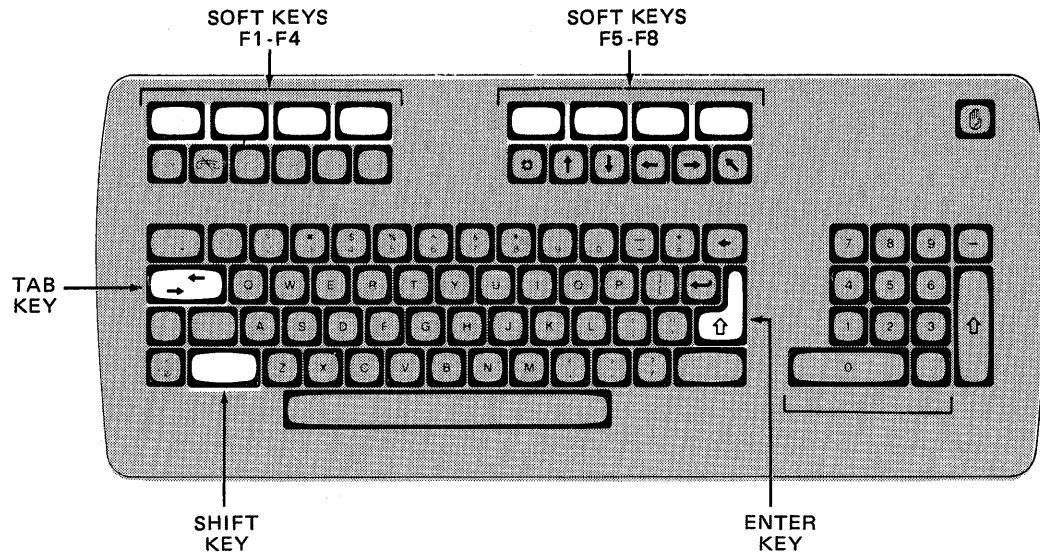

HP 2622D Softkey Labels and Keyboard

Note: The softkey labels on the display screen correspond to the softkeys on the top row of the keyboard.

1. Configure the 2622D workstation by pressing the F1 key while holding the SHIFT key down. You may then select the options listed on the screen by pressing softkeys F1, F2, F3, and F4. The following screen appears:

WORKSTATION CONFIGURATION							
Baud Rate	9600	Frame Rate	60				
Minus Key	MINUS	Modem Key	IGNORE				
		Chars/Line	80				
SAVE CONFIG	NEXT CHOICE	PREVIOUS CHOICE	DEFAULT VALUES				

HP 2622D Configuration Screen

2. If the screen on your display is identical to the one pictured above, go to step 4. Note that the value in the Frame Rate field should be the same as the power line frequency in your country (50 Hz or 60 Hz).
3. If the screen on the display is not identical to the one above, follow these instructions.
 - a. Press the DEFAULT VALUES softkey. This sets all option values to their preset values.
 - b. If the screen is still not identical to the one above, use the TAB key to position the cursor in the field that is wrong, then press NEXT CHOICE or PREVIOUS CHOICE until the correct values appear.
 - c. When all values are set as you want them, press SAVE CONFIG to record all the changes.
4. Turn the workstation power switch off.

5. Connect the narrow end of the RS-232-C cable to port 1 on the system rear panel. Connect the wide end to the port 1 or "Data Comm" receptacle on the back panel of the display.

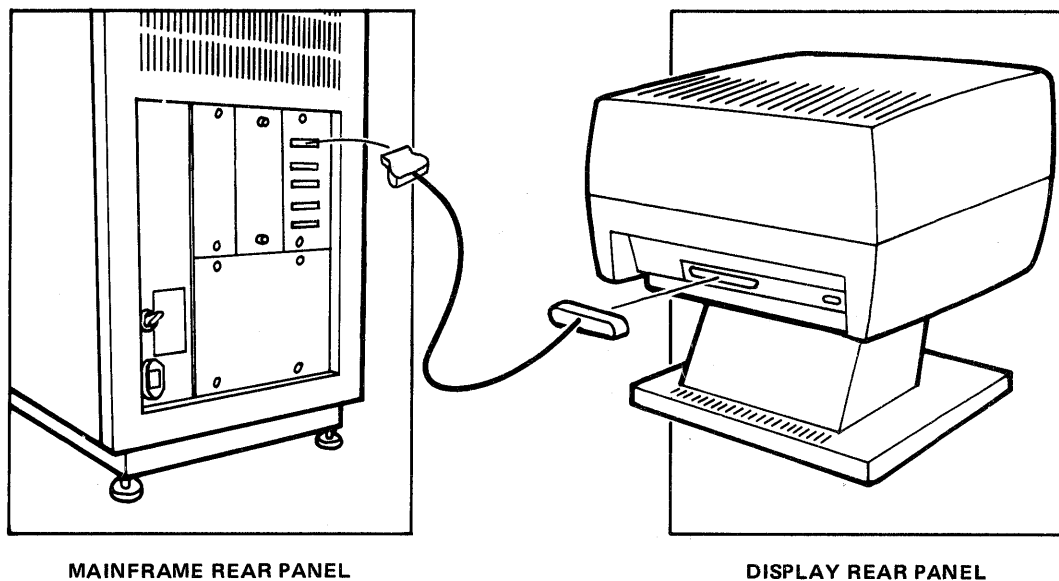

Connecting the HP 2622D Workstation to the Mainframe

6. Turn the workstation power switch on.

Installation

Loading from a Flexible Disc Drive

Now you are ready to load the software from the flexible discs. The OPERATING SYSTEM disc contains required information for system operation, and must be loaded first. The process of starting the computer with the OPERATING SYSTEM disc is called "loading the system."

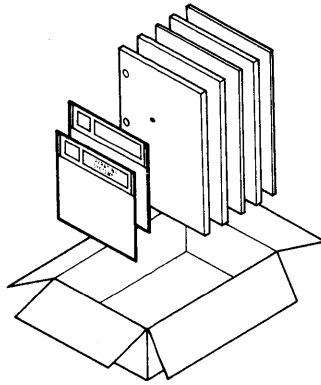

HP 250 Manual Set and System Software

1. Open the flexible disc drive door by pressing the small bar on the drive. Insert the OPERATING SYSTEM disc until it clicks into place. Pull the door down until it latches.

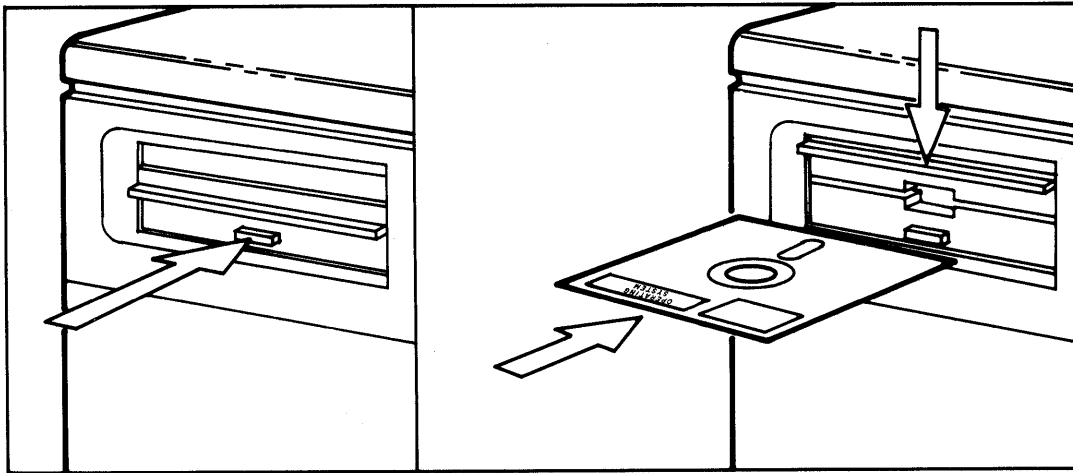

Inserting a Flexible Disc into the Drive

2. Turn the key on the mainframe clockwise to position "1". The door automatically locks itself, and the system begins to read the data on the disc. A SYSTEM LOADING message appears on the screen, and a blinking light on the drive indicates that it is in use.

NOTE

If the light on the drive never blinks, the disc might have been inserted improperly. Turn the system off with the key, open the door, and start at step 1. If the light still doesn't blink, be sure the mainframe is plugged into the wall, the workstation is plugged into the mainframe, that the system circuit breaker on the rear panel above the power cord is ON, and that the circuit breaker for the wall outlet is ON.

If there is still no response, call your HP Customer Engineer for assistance (See Appendix C).

Installation

3. A system self-test is performed automatically whenever the system is turned on. A message in the form:

SYSTEM LOADING

followed by:

LOADING DROMS

appears on the screen. The message remains on the screen about 30 seconds. The cursor, a blinking underscore, appears when the loading process is finished.

If the message:

The "SYSTEM" file was not found.

appears during loading, the OPERATING SYSTEM disc was not inserted into the drive, or was not inserted properly. In this case, turn the key to the "0" (off) position and restart the loading procedure.

If the result of the self-test is an error message, or if the system failed to load, write any screen messages in the system log book and try the steps again. If trouble persists, see the section "In Case of Difficulty" in the manual "Operating the HP 250" (part No. 45260-90002).

HP 2631B Printer Installation

1. Turn off the HP 250 by turning the key to the 0 (off) position.
2. Place the printer on a table near the mainframe. Do not place it on the mainframe, box, or other peripheral.
3. Be sure the printer's power switch is off.

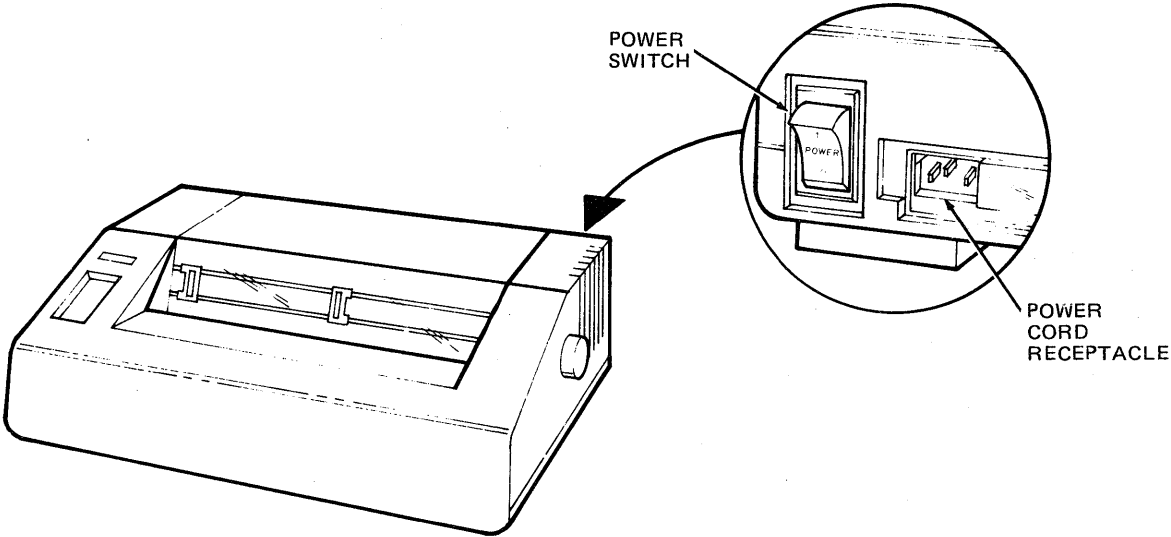

HP 2631B Printer Power Switch Location

4. Lift the front cover and set the switches as follows:

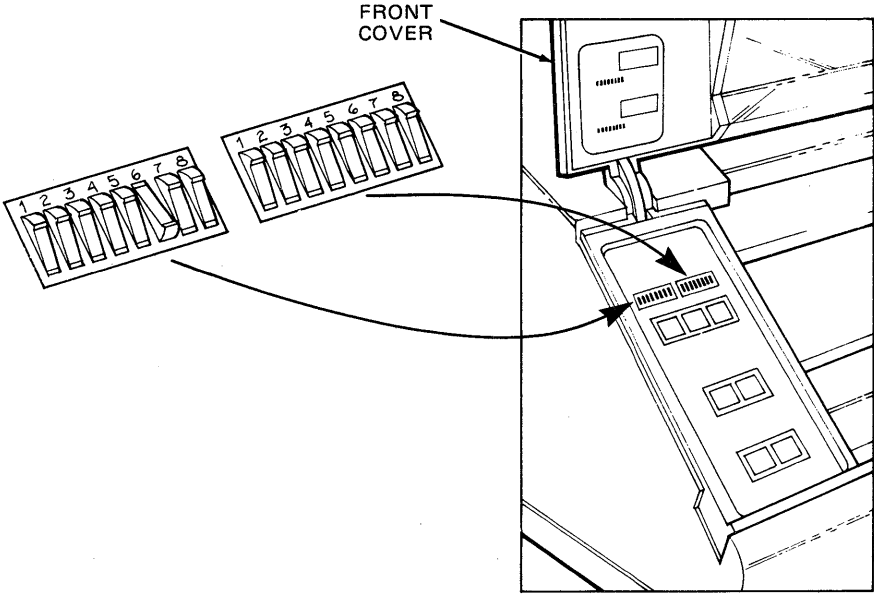

HP 2631B Printer Switch Settings (Inside Front Cover)

Installation

5. Install the ribbon cartridge and paper.

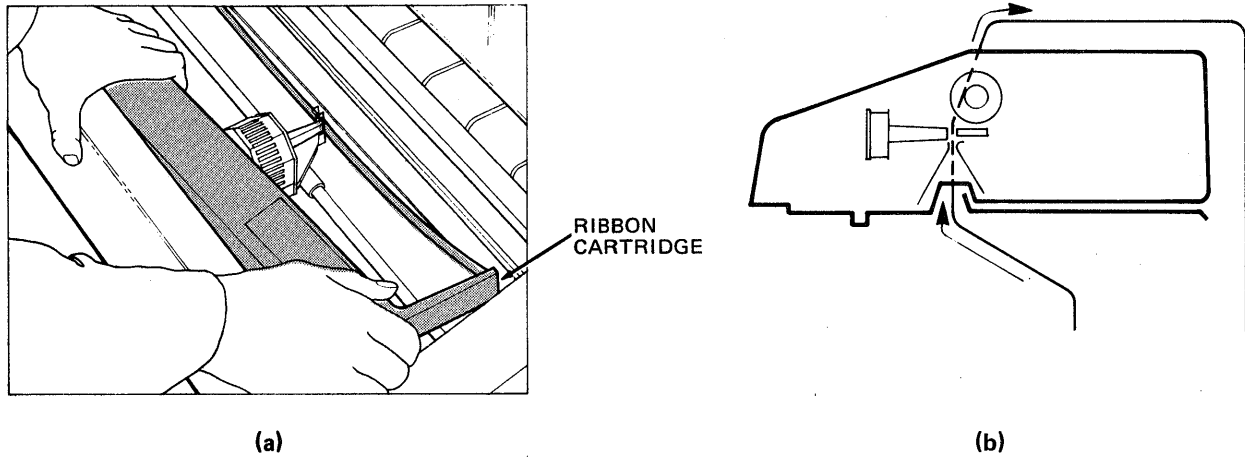

HP 2631B -- Installing the (a) Ribbon Cartridge and (b) Paper

6. Be sure the power switch is off.
7. Connect the power cord to the printer, then the wall outlet.

8. Turn the power on.

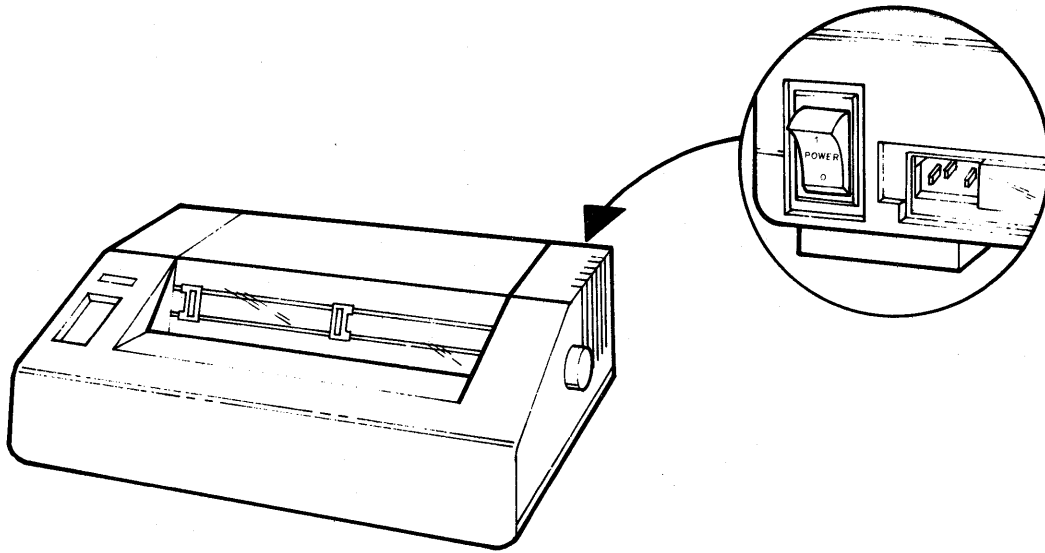

HP 2631B Power Switch Location

9. Press the Off Line/On Line button until the red light is off.

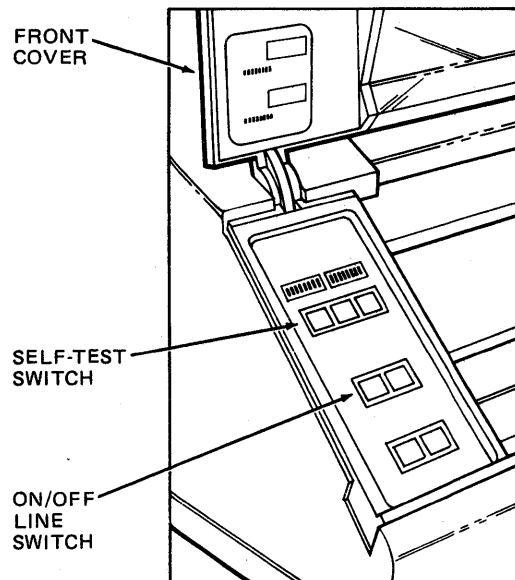

HP 2631B On-Line and Self-Test Switch Locations

NOTE

If you are using a current loop connection, follow these steps:

- a. Remove the door covering the switches on the mainframe's back panel by pulling the black knobs toward you.

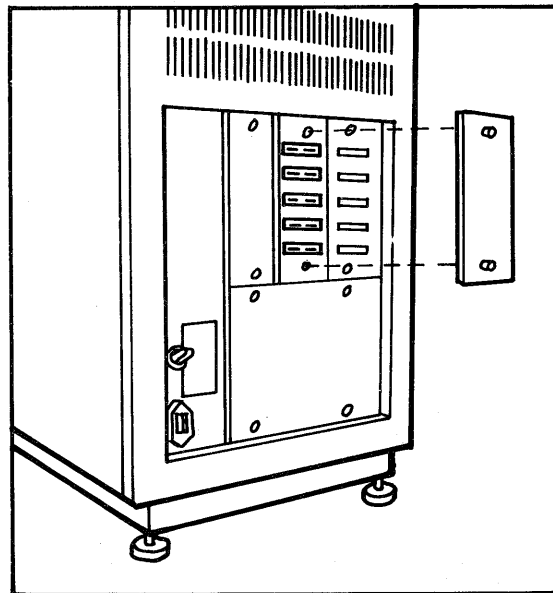

Mainframe Rear Panel Configuration Switches

- b. Locate the set of switches corresponding to the current loop port. Each set of 2 switch panels corresponds to the port beside it as described on the legend at the left of the switch door. (Ports 1-5 are on the upper panel and the optional ports, 6-10, are on the lower panel.)
- c. For each current loop port, set the switches for a Current Loop Port as described behind the cover panel.

Installation

13. Set the switches on the printer's rear panel (by the RS-232 connector) as follows:

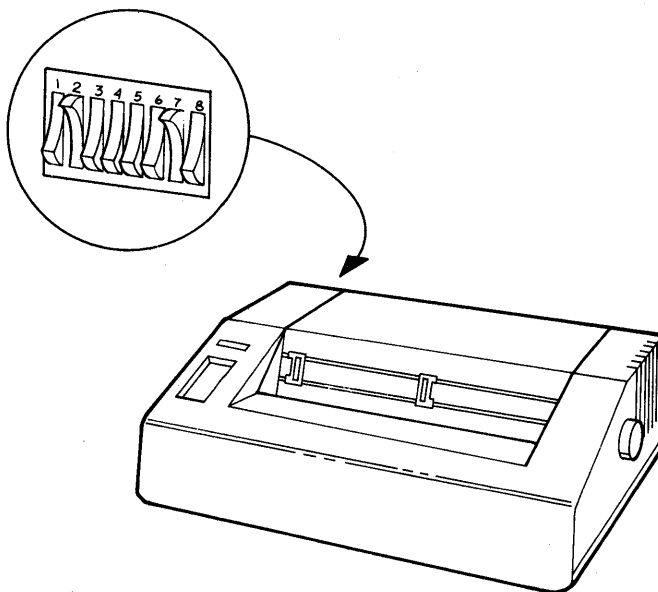

HP 2631B Rear Panel Switches

If you only install an HP 2631B printer, skip to the "Printer System Test" in this chapter.

HP 2601A Printer Installation

1. Turn off the HP 250 by turning the key to the 0 position.
2. Place the printer on a table or work surface near the mainframe. Do not place it on the mainframe, box, or other peripheral.
3. Make sure the printer's power switch is off.

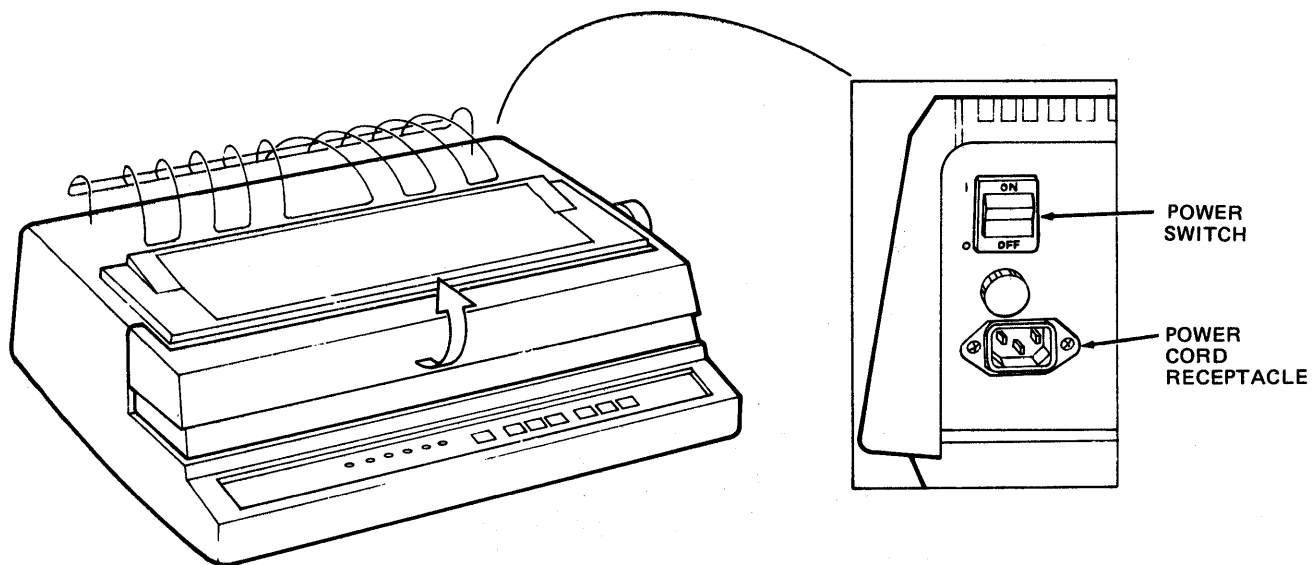

HP 2601A Power Switch Location

4. Remove the access cover.

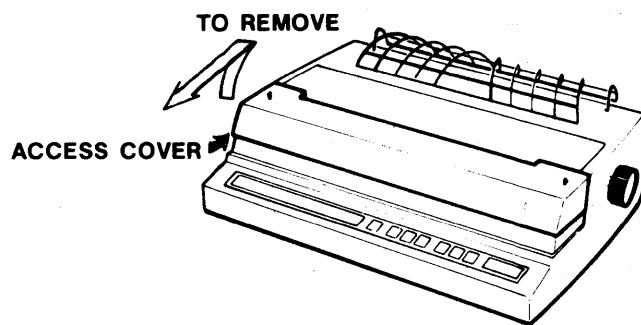

HP 2601A -- Removing the Access Cover

Installation

5. Set the switches at the front of the printer as follows:

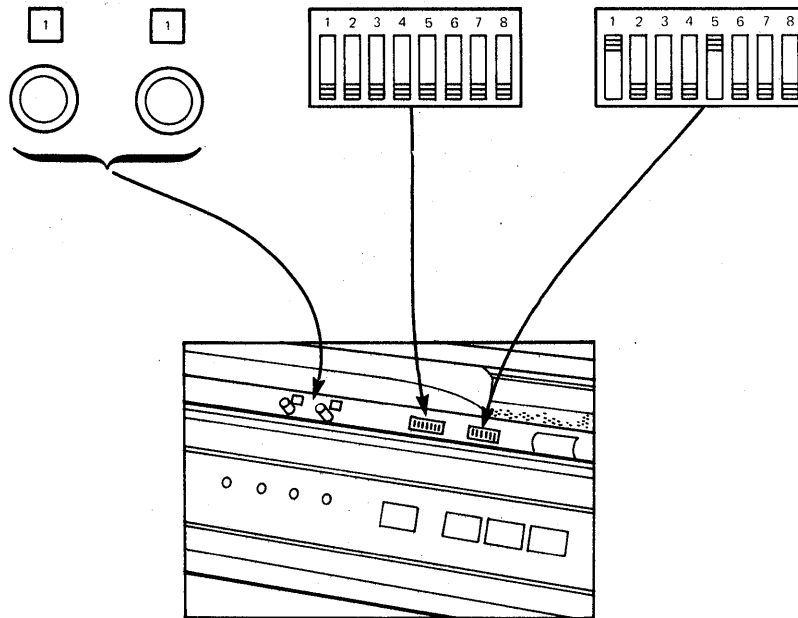

HP 2601A Switch Settings (Inside Front Cover)

6. With the front cover up, install the print wheel and ribbon. Refer to the HP 2601A Operator's Manual for these instructions in Section III, PREPARING YOUR PRINTER FOR USE.
7. Load paper. Put paper in the printer the same way you put paper in a typewriter.
8. Connect the power cord to the printer, then to the wall outlet.
9. Perform the self-test. With the power off, set the spacing switch to 4, then replace the access cover and turn on the power. The self-test results should look like this:

```

selftest
hpro9 rom ok
hpro9 ram ok
pce rom ok
rarr ok
pw ok
>!"#$%&'()*+,-./0123456789:;[=?@ABCDEFGHIJKLMNopqrstuvwxyZ`{|}~<abcde fghij klmnopqr stuvwxyz"'^>!"#$%&'()*+,-./0123456789:;[=?@ABC
!"#$%&'()*+,-./0123456789:;[=?@ABCDEFGHIJKLMNopqrstuvwxyZ`{|}~<abcde fghij klmnopqr stuvwxyz"'^>!"#$%&'()*+,-./0123456789:;[=?@ABCD
!"#$%&'()*+,-./0123456789:;[=?@ABCDEFGHIJKLMNopqrstuvwxyZ`{|}~<abcde fghij klmnopqr stuvwxyz"'^>!"#$%&'()*+,-./0123456789:;[=?@ABCDE
!"#$%&'()*+,-./0123456789:;[=?@ABCDEFGHIJKLMNopqrstuvwxyZ`{|}~<abcde fghij klmnopqr stuvwxyz"'^>!"#$%&'()*+,-./0123456789:;[=?@ABCDEF
!"#$%&'()*+,-./0123456789:;[=?@ABCDEFGHIJKLMNopqrstuvwxyZ`{|}~<abcde fghij klmnopqr stuvwxyz"'^>!"#$%&'()*+,-./0123456789:;[=?@ABCDEFG
!"#$%&'()*+,-./0123456789:;[=?@ABCDEFGHIJKLMNopqrstuvwxyZ`{|}~<abcde fghij klmnopqr stuvwxyz"'^>!"#$%&'()*+,-./0123456789:;[=?@ABCDEFGH
!"#$%&'()*+,-./0123456789:;[=?@ABCDEFGHIJKLMNopqrstuvwxyZ`{|}~<abcde fghij klmnopqr stuvwxyz"'^>!"#$%&'()*+,-./0123456789:;[=?@ABCDEFGH

```

HP 2601A Self-Test Results

10. After approximately 25 lines of self-test are printed out, turn the printer off at the power switch.
11. Lift the front cover and set the spacing switch to 1 (10 characters per inch).
12. Connect the RS-232-C cable (supplied with the printer) to the printer, then to the mainframe at port 4. Be sure to fit the cables correctly. The cable only fits one way into the receptacle. Both ends of the cable fit the mainframe and the printer.

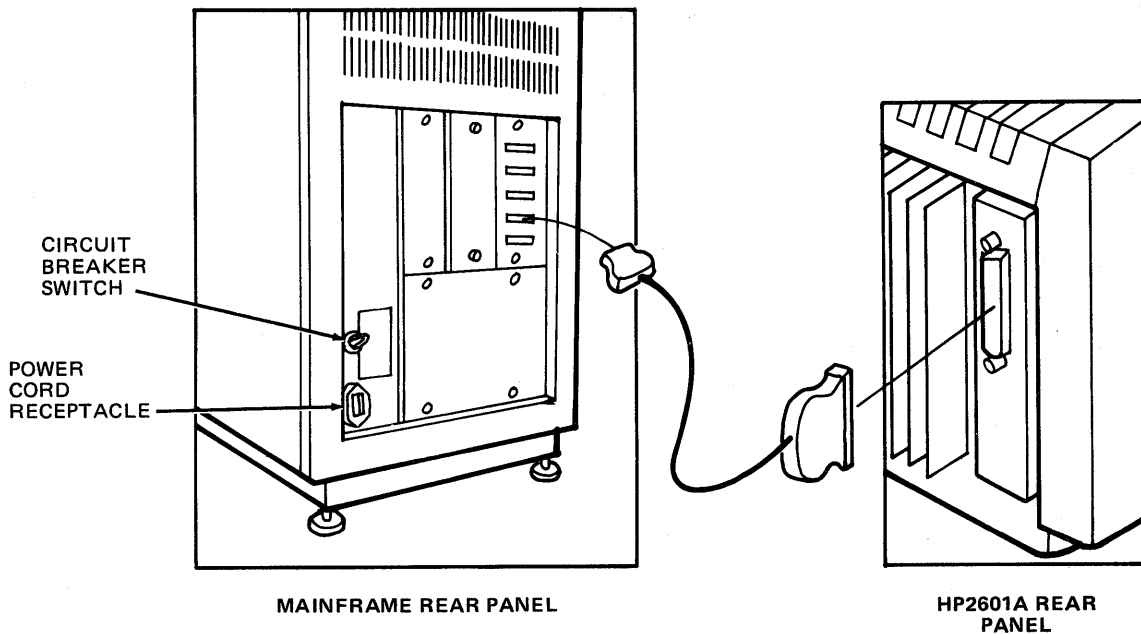

Connecting the HP 2601A to the Mainframe

Installation

HP 2602A Printer Installation

1. Turn off the HP 250 by turning the key to the 0 position.
2. Place the printer on a table or work surface near the mainframe. Do not place it on the mainframe, box, or other peripheral.
3. Make sure the printer's power switch is off.

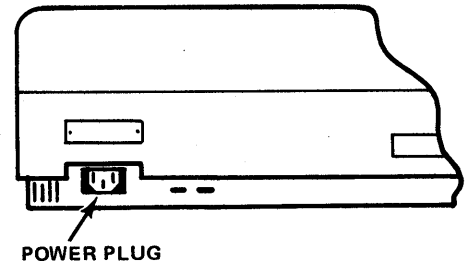
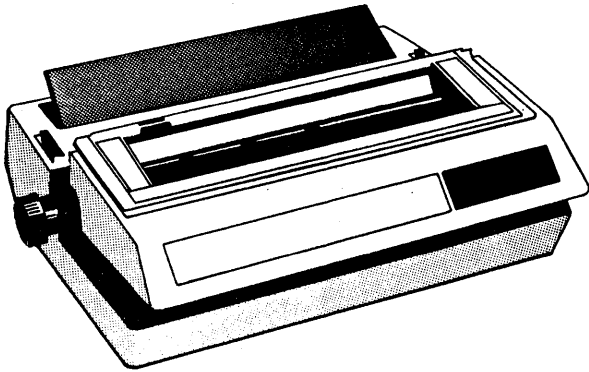

HP 2602A Power Plug Location

4. Remove the access cover.

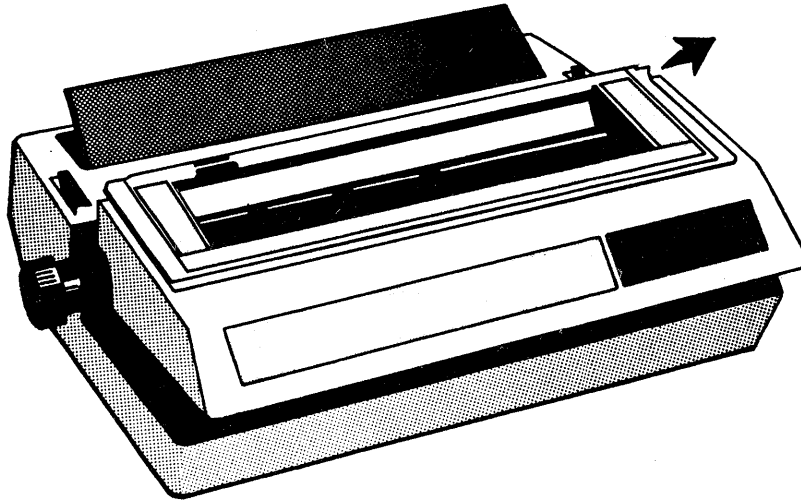

HP 2602A -- Removing the Access Cover

5. Set the printer front panel switches as follows:

SWITCH NUMBER	MEANING	DIRECTION OF SWITCH	MEANING
8	SINGLE-STRIKE RIBBON (ON)	AS REQUIRED	SINGLE-STRIKE RIBBON (OFF)
7	12 IN. PAPER	AS REQUIRED	11 IN. PAPER
6	SELF TEST ON	<input type="checkbox"/>	SELF TEST OFF
5	PRINTER RDY	<input type="checkbox"/>	DC1/DC3
4	PARITY ON	<input type="checkbox"/>	PARITY OFF
3	ODD PARITY	<input type="checkbox"/>	EVEN PARITY
2	110 BAUD	<input type="checkbox"/>	300 BAUD
1	110 OR 300 BAUD	<input type="checkbox"/>	1200 BAUD

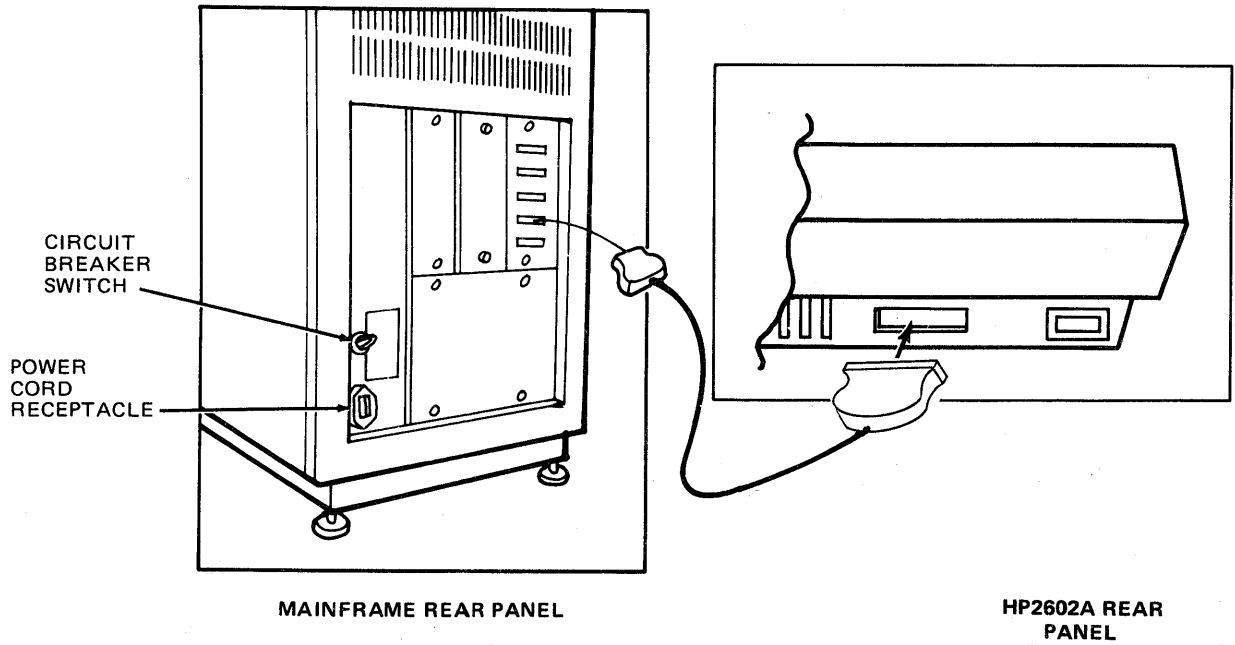

Connecting the HP 2602A to the Mainframe

HP 82905B Printer Installation

1. Turn off the HP 250 by turning the key to the 0 position.
2. Place the printer on a table or work surface near the mainframe. Do not place it on the mainframe, box, or other peripheral.
3. Make sure the printer power switch is off.
4. With the front cover up, install the paper and ribbon. Refer to the HP 82905B Operator's Manual for these instructions.
5. Connect the power cord to the printer, then to the wall outlet.
6. Perform the self-test. The self-test verifies the mechanical and and electronic integrity of the HP 82905B, independent of its connection to the HP 250. To perform the test, turn on the AC power while pressing the LF switch. The printer will print all standard characters in a ripple pattern.

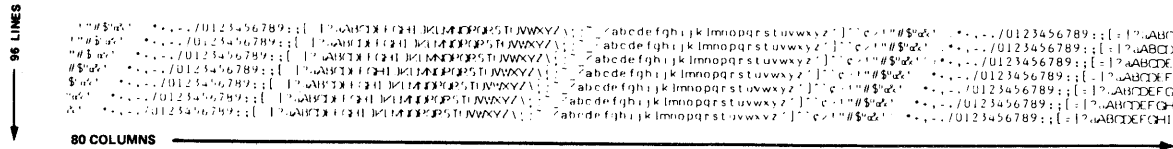

HP 82905B Self-Test Results

7. After approximately 25 lines of self-test are printed out, turn the printer off at the power switch.

8. With the RS-232-C cable, connect the printer to port 5 of the HP 250. Be sure the switches for port 5 on the HP 250 back panel (under the cover plate) look like this:

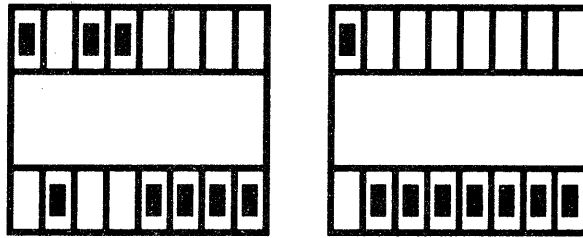

NOTE

The HP 82905B operates with HP 250 Option 033 only. Call your Customer Engineer if you do not own Option 033.

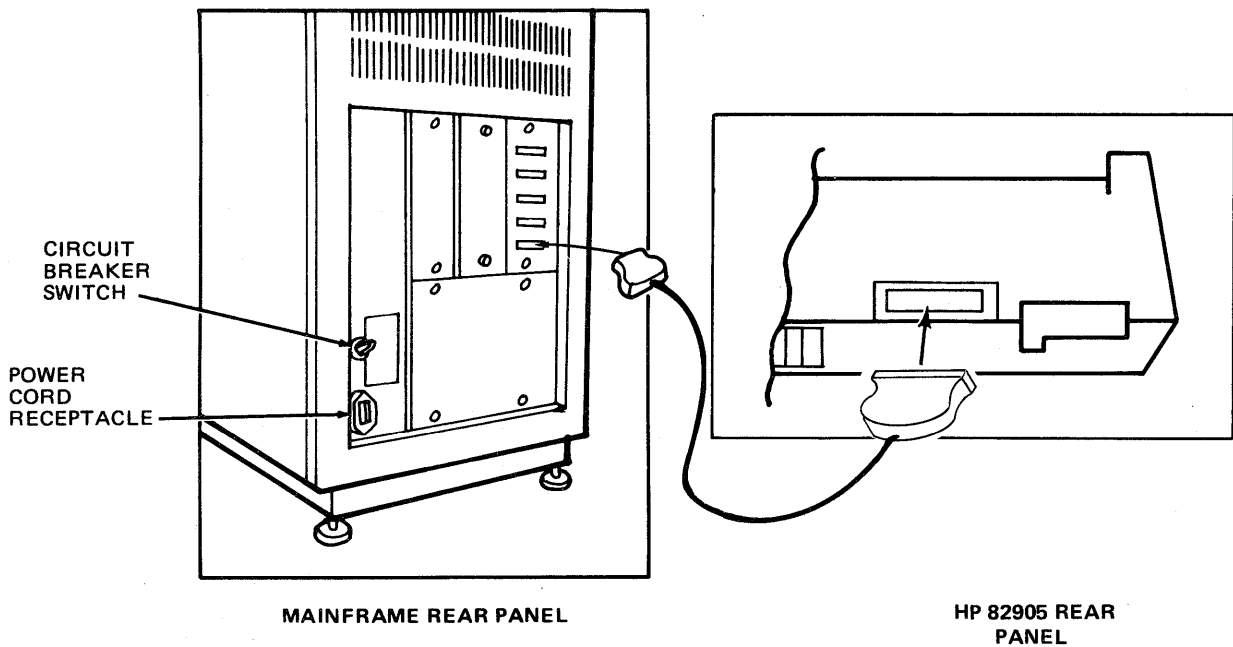

Connecting the HP 82905B to the Mainframe

HP 2932A, 2933A, AND 2934A PRINTER INSTALLATION

1. Turn off the HP 250 by turning the key to the 0 position.
2. Place the printer on a table or work surface near the mainframe. Do not place it on the mainframe, box, or other peripheral.
3. Make sure the printer power switch is off.
4. Check fuse and voltage setting for the printer, then install the ribbon and paper as shown in the HP 2930 Series Printers Owner's Manual.
5. Connect the power cord to the printer, then to the wall outlet.
6. Turn power on and perform the printer's internal self-test. (Refer to the HP 2930 Series Printer Owner's Manual.) "SELF TEST PASSED" will print if the self-test is passed.
7. Using the HP 2930 Series Printers Operator's Manual, configure the HP 2932 as follows:

NOTE

Configuration involves printer and interface settings. The settings that are shown in bold print are required. The remainder of the settings are optional.

**** **PRINTER SETTINGS** ****

PRINT SETTINGS	PAGE SETTINGS	MARGIN SETTINGS	OTHER SETTINGS	SET DEFAULTS				
**** PRINT SETTINGS ****								
PRIMARY PRINT PITCH 10	SECONDARY PRINT PITCH 10	PRIMARY STYLE Cubic	SECONDARY STYLE Cubic	<table style="width: 100%; border: none;"> <tr> <td style="text-align: center;"> <table style="width: 100%; border: none;"> <tr> <td style="text-align: center;">**** PRIMARY CHARACTER SET Roman8</td> <td style="text-align: center;">SECONDARY CHARACTER SET Line Draw</td> <td style="text-align: right;">ALL</td> </tr> </table> </td> </tr> </table>	<table style="width: 100%; border: none;"> <tr> <td style="text-align: center;">**** PRIMARY CHARACTER SET Roman8</td> <td style="text-align: center;">SECONDARY CHARACTER SET Line Draw</td> <td style="text-align: right;">ALL</td> </tr> </table>	**** PRIMARY CHARACTER SET Roman8	SECONDARY CHARACTER SET Line Draw	ALL
<table style="width: 100%; border: none;"> <tr> <td style="text-align: center;">**** PRIMARY CHARACTER SET Roman8</td> <td style="text-align: center;">SECONDARY CHARACTER SET Line Draw</td> <td style="text-align: right;">ALL</td> </tr> </table>	**** PRIMARY CHARACTER SET Roman8	SECONDARY CHARACTER SET Line Draw	ALL					
**** PRIMARY CHARACTER SET Roman8	SECONDARY CHARACTER SET Line Draw	ALL						
**** PAGE SETTINGS ****								
	LINES PER INCH 6	INCHES PER PAGE 11	PERFORATION SKIP off	<table style="width: 100%; border: none;"> <tr> <td style="text-align: center;">TEXT LINES PER PAGE 60</td> <td style="text-align: right;">ALL</td> </tr> </table>	TEXT LINES PER PAGE 60	ALL		
TEXT LINES PER PAGE 60	ALL							
**** MARGIN SETTINGS ****								
		LEFT MARGIN 0	RIGHT MARGIN 135	ALL				

**** OTHER SETTINGS ****

DISPLAY FUNCTIONS off	HP TERMINAL MODE off	RESTRICTED SEQUENCES none	CR AUTO LF off	LF, VT & FF AUTO CR off	SUPPORT MODE 2932A
-------------------------------------	------------------------------------	---	------------------------------	---	----------------------------------

**** END OF SETTINGS ****

**** INTERFACE SETTINGS ****

**** SERIAL ****

DATA SETTINGS

CONTROL SETTINGS

SET DEFAULTS

**** DATA SETTINGS ****

BAUD RATE 9600	DATA BITS 8	PARITY none	PARITY CHECK off	STRIP NULL/DEL off	ALL
--------------------------	-----------------------	-----------------------	----------------------------	------------------------------	------------

**** CONTROL SETTINGS ****

XON/XOFF off	ENQ/ACK on	BINARY ENQ/ACK off	DTR/CD High	(S)RTS/SCA Low	CTS/CB ignore	RS/CH Low
------------------------	----------------------	------------------------------	-----------------------	--------------------------	-------------------------	---------------------

**** END OF SETTINGS ****

8. Using the HP 2930 Series Printers Operator's Manual, configure the HP 2933 and HP 2934 as follows:

NOTE

Configuration involves printer and interface settings. The settings that are shown in bold print are required. The remainder of the settings are optional.

**** PRINTER SETTINGS ****

PRINT SETTINGS PAGE SETTINGS MARGIN SETTINGS OTHER SETTINGS SET DEFAULTS

		**** PRINT SETTINGS ****				ALL
PRIMARY PRINT PITCH	SECONDARY PRINT PITCH	PRIMARY STYLE	SECONDARY STYLE	PRIMARY CHARACTER SET	SECONDARY CHARACTER SET	
10	10	Cubic	Cubic	Roman8	Math	

**** PAGE SETTINGS ****

LINES PER INCH	INCHES PER PAGE	PERFORATION SKIP	TEXT LINES PER PAGE	ALL
6	11	off	60	

**** MARGIN SETTINGS ****

LEFT MARGIN	RIGHT MARGIN	ALL
0	135	

**** OTHER SETTINGS ****

DISPLAY FUNCTIONS	HP TERMINAL MODE	RESTRICTED SEQUENCES	CR AUTO LF	LF, VT & FF AUTO CR	SUPPORT MODE
off	off	none	off	off	2934A

**** END OF SETTINGS ****

**** INTERFACE SETTINGS ****

**** SERIAL ****

DATA SETTINGS CONTROL SETTINGS SET DEFAULTS

**** DATA SETTINGS ****

BAUD RATE	PARITY	PARITY CHECK	DATA BITS	STRIP NULL/DEL	ALL
9600	none	off	8	off	

**** CONTROL SETTINGS ****

XON/XOFF	ENQ/ACK	BINARY ENQ/ACK	DTR/CD	(S)RTS/SCA	CTS/CB	RS/CH
off	on	off	High	Low	ignore	Low

**** END OF SETTINGS ****

9. Connect the RS-232-C cable to port 5 on the HP 250 back panel and to the printer.

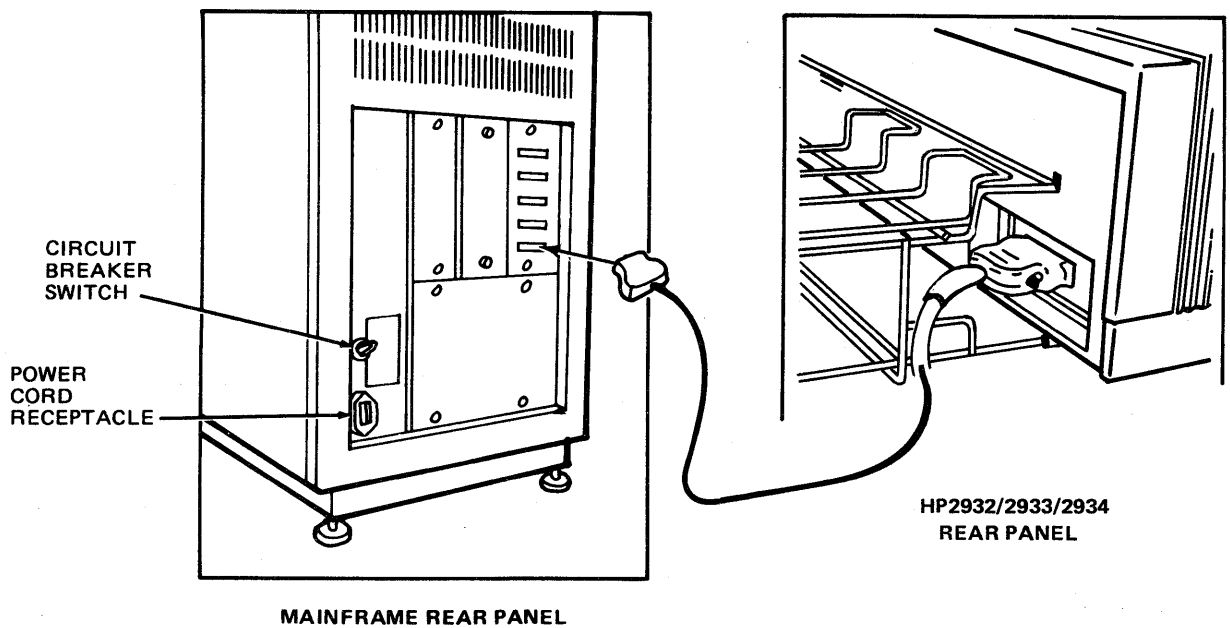

HP 2563A PRINTER INSTALLATION

1. Turn off the HP 250 by turning the key to the 0 position.
2. Place the printer on a table or work surface near the mainframe. Do not place it on the mainframe, box, or other peripheral.
3. Make sure the printer power switch is off.
4. Lift the access cover and install the paper and ribbon. (Refer to the HP 2563A Operator's Manual for these instructions.)
5. Connect the power cord to the printer, then to the wall outlet.
6. Turn the printer power switch on. Perform the self-test. To perform the standard self-test function (excluding I/O tests), depress the TEST key once to enter the test mode and then press the ENTER key to begin test execution. To run a continuous standard self-test, depress the TEST key for more than five seconds (until a number 4 appears on the display) and then press the ENTER key. Self-test can be exited any time by pressing either the TEST or ON LINE keys momentarily.

If the TEST switch is pressed for more than one second, the printer will enter a continuous test mode. To stop continuous testing, again press the TEST switch.

7. To configure the printer, proceed as follows:

The function numbers shown in this table must be set to the parameter value shown. To do this, follow the steps listed here (refer to the HP 2563A Operator's Manual for more information.)

<u>Function Number</u>	<u>Parameter Value</u>
20	01
21	00
22	51
23	00

- a. Press the ON LINE key. The on line indicator will go out.
- b. Press the CONFIG key, and at the same time press either FINE ADJUST keys (increment or decrement) until the desired function number is displayed.
- c. Release the CONFIG key. The display now shows the parameter value currently assigned to the function number.
- d. Using the FINE ADJUST keys, select the parameter value shown in the above table.

Installation

- e. Press the ENTER key. The new parameter value will be entered and the printer will return to the STATUS mode.
 - f. Repeat steps a. through d. for each parameter value change required.
8. Connect the RS-232-C interface cable to the printer, and to port 5 on the HP 250.

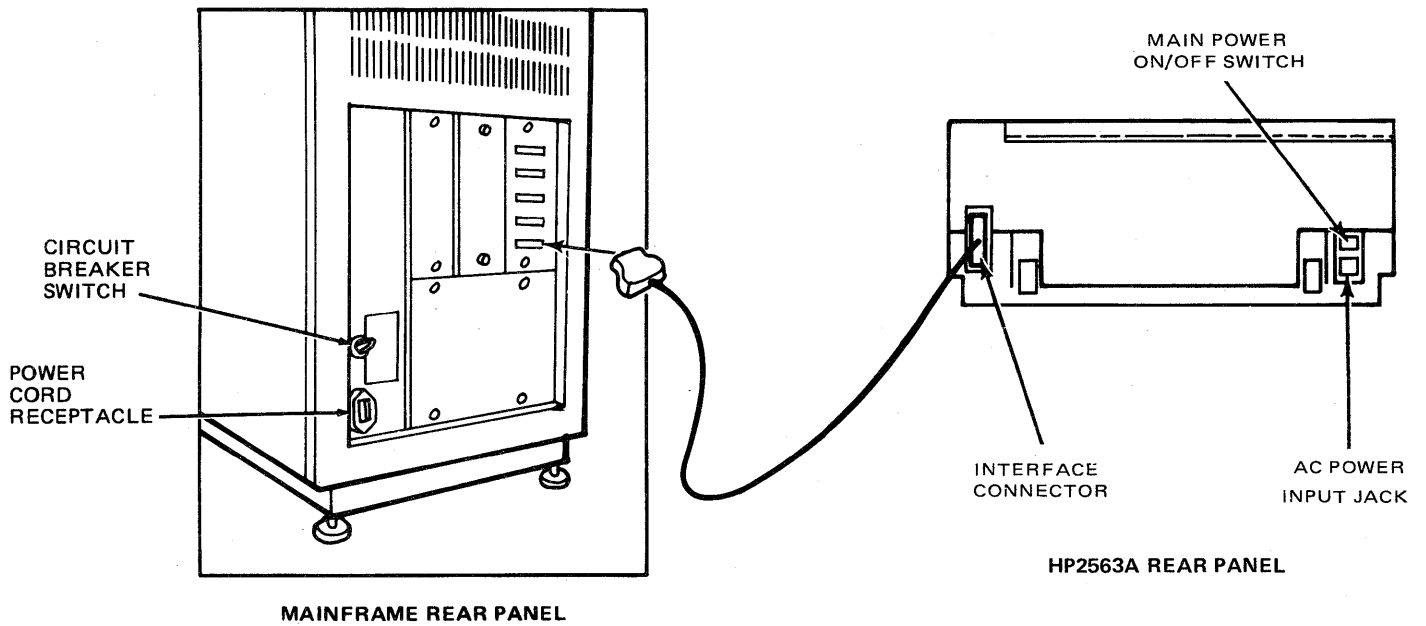

HP 2687A PRINTER INSTALLATION

1. Turn off the HP 250 by turning the key to the zero position.
2. Unpack and prepare your page printer and controller for use according to the information provided in the HP 2687A Operator's Manual.
3. Place the page printer on a table or work surface near the mainframe. Do not place it on the mainframe, box, or other peripheral.
4. Make sure the page printer power switch is off.
5. Install paper and toner. (Refer to the HP 2687A Operator's Manual HP 2683A Installation Manual and HP 26087A Installation Manual for this information.)
6. Connect the power cord to the printer, then to the wall outlet.
7. Turn the page printer power switch on and perform the self-tests. There are two tests, one for the printer and one for the controller.

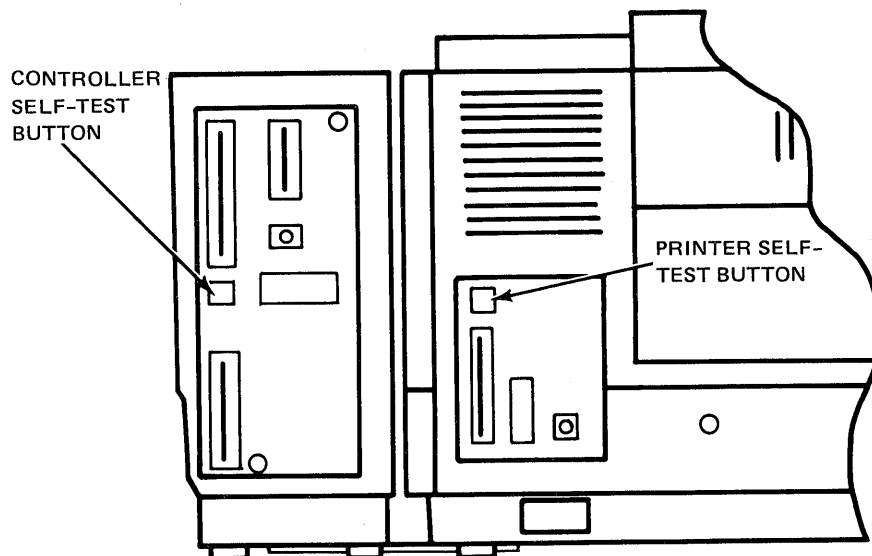

Installation

8. Observe the self-test patterns. If either self-test does not print properly or the SERVICE REQUIRED indicator flashes, refer to the HP 2687A Operator's Manual for further instructions.

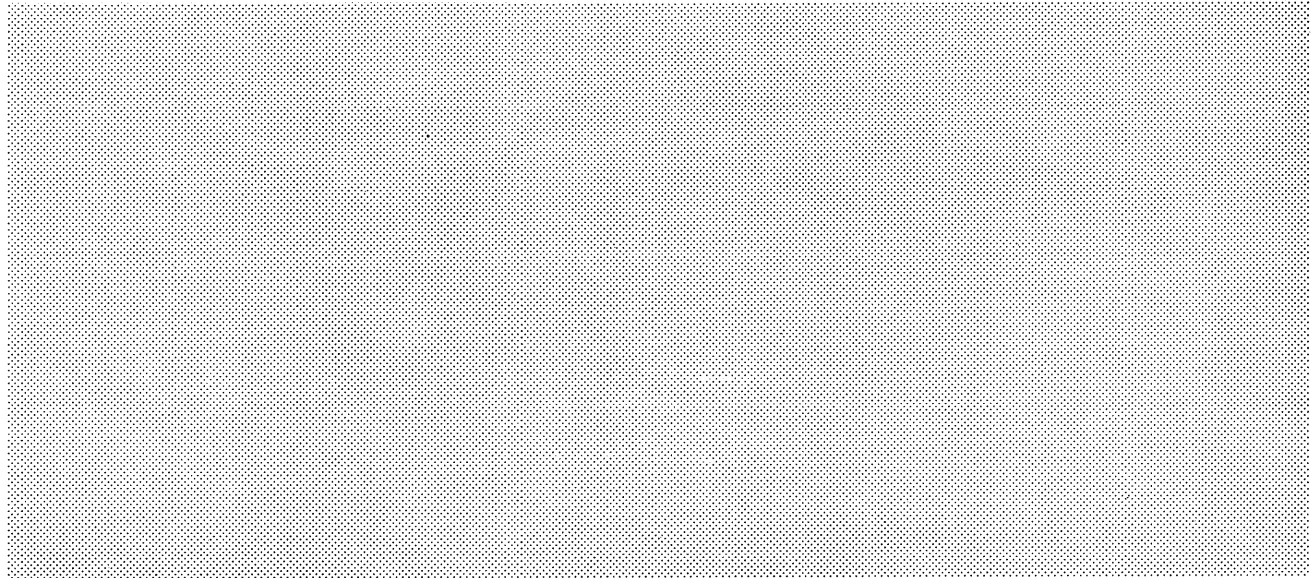

PRINTER SELF-TEST PATTERN

```
!"#$%&'()*+,-./0123456789:;<=>?@ABCDEFGHIJKLMNOPQRSTUVWXYZ[\]^_`
' abcdefghijklmnopqrstuvwxyz{|}~ ¸Ńñ; ;f$ àèùäöüÄiØÆáíøæÀi ÖÜÈi
!"#$%&'()*+,-./0123456789:;<=>?@ABCDEFGHIJKLMNOPQRSTUVWXYZ[\]^_`
' abcdefghijklmnopqrstuvwxyz{|}~ ¸Ńñ; ;f$ àèùäöüÄiØÆáíøæÀi ÖÜÈi
!"#$%&'()*+,-./0123456789:;<=>?@ABCDEFGHIJKLMNOPQRSTUVWXYZ[\]^_`
' abcdefghijklmnopqrstuvwxyz{|}~ ¸Ńñ; ;f$ àèùäöüÄiØÆáíøæÀi ÖÜÈi
!"#$%&'()*+,-./0123456789:;<=>?@ABCDEFGHIJKLMNOPQRSTUVWXYZ[\]^_`
' abcdefghijklmnopqrstuvwxyz{|}~ ¸Ńñ; ;f$ àèùäöüÄiØÆáíøæÀi ÖÜÈi
!"#$%&'()*+,-./0123456789:;<=>?@ABCDEFGHIJKLMNOPQRSTUVWXYZ[\]^_`
' abcdefghijklmnopqrstuvwxyz{|}~ ¸Ńñ; ;f$ àèùäöüÄiØÆáíøæÀi ÖÜÈi
!"#$%&'()*+,-./0123456789:;<=>?@ABCDEFGHIJKLMNOPQRSTUVWXYZ[\]^_`
' abcdefghijklmnopqrstuvwxyz{|}~ ¸Ńñ; ;f$ àèùäöüÄiØÆáíøæÀi ÖÜÈi
!"#$%&'()*+,-./0123456789:;<=>?@ABCDEFGHIJKLMNOPQRSTUVWXYZ[\]^_`
' abcdefghijklmnopqrstuvwxyz{|}~ ¸Ńñ; ;f$ àèùäöüÄiØÆáíøæÀi ÖÜÈi
!"#$%&'()*+,-./0123456789:;<=>?@ABCDEFGHIJKLMNOPQRSTUVWXYZ[\]^_`
' abcdefghijklmnopqrstuvwxyz{|}~ ¸Ńñ; ;f$ àèùäöüÄiØÆáíøæÀi ÖÜÈi
```

CONTROLLER SELF-TEST PATTERN

9. Turn the page printer power switch off. Connect the RS-232-C interface cable to the controller portion of the page printer and to port 5 on the HP 250.

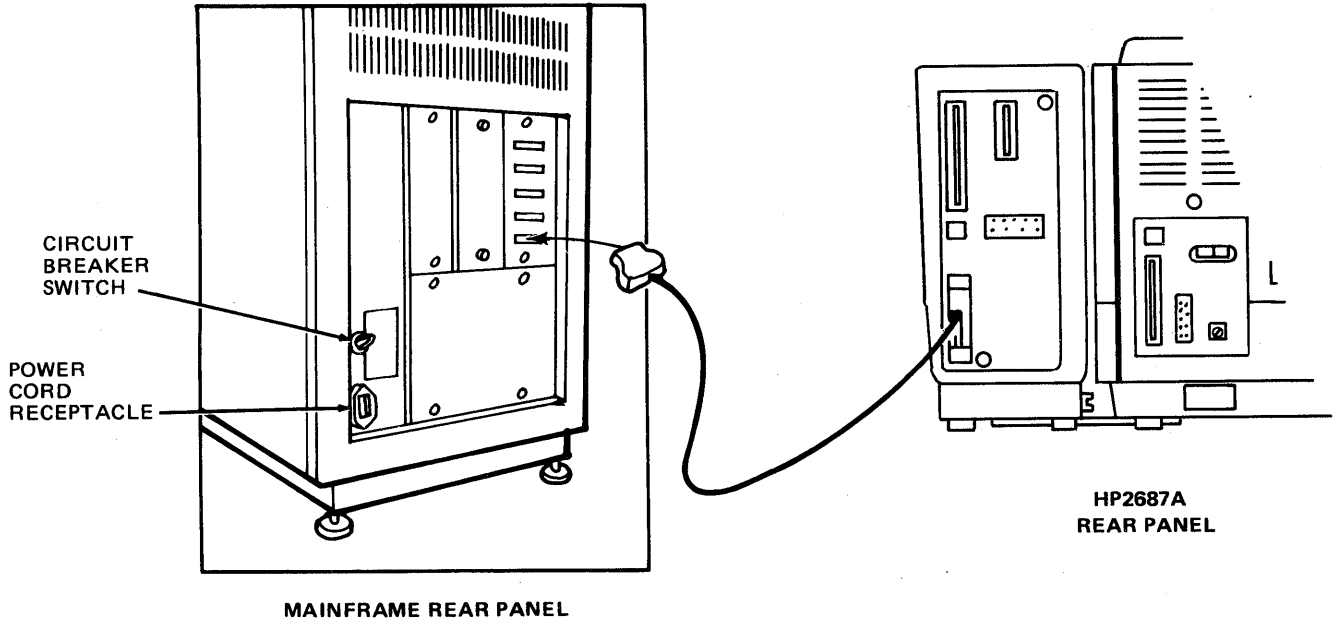

CONFIGuring Printers

CONFIG is a special program on the OPERATING SYSTEM disc which lets you tell the system what hardware is attached to it. The keys and softkeys needed to run CONFIG are identified below. The manual "Operating the HP 250" contains information about all of the keys and their functions.

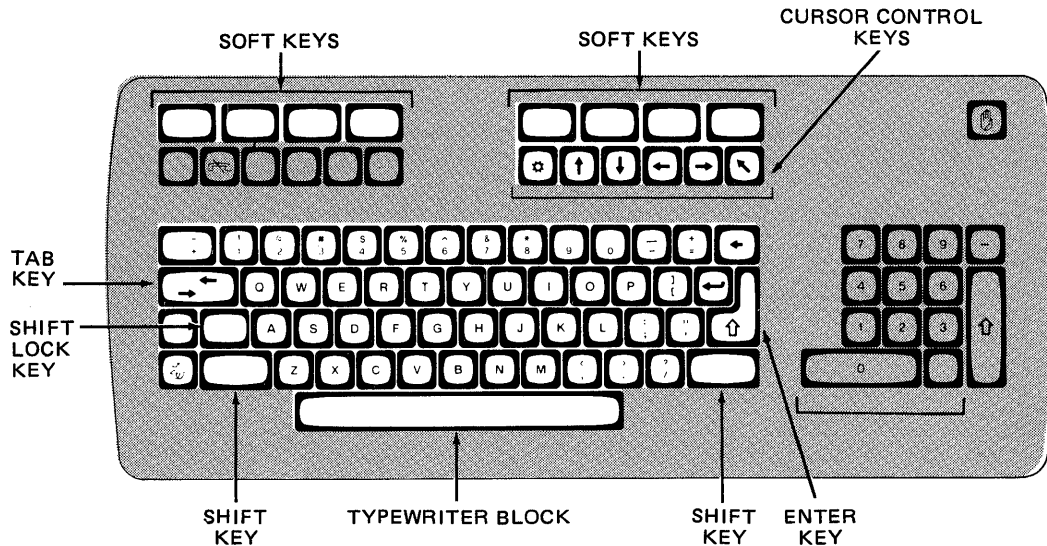

HP 2622D Keyboard -- CONFIG Keys and Softkeys Highlighted

1. Turn on the system (turn the key from 0 to 1 with the OPERATING SYSTEM disc in the drive).
2. When the cursor (blinking underscore) appears, Type: RUN "CONFIG" and press the ENTER key.
3. When the HP 250 System Configuration screen appears, enter 9 to access the Remote I/O Configuration screen.

NOTE

The following screen is an example that lists only two printer models. Other configured printers will be displayed in a similar manner.

```

HP250.5.F          HP 250 REMOTE I/O CONFIGURATION

  Port  Class  ID  Type  Format  Nulls  Remarks
-----
DESK  none
  1  Workstn  2622
  2  none
  3  none
  4  Printer  14  2601  8N1
  5  Printer  15  905B
  6  none
  7  none
  8  none
  9  none
 10  none

Main workstation
HP 2601 PRINTER
HP 82905B PRINTER

2 secondary tasks are configured.

Please select a function.

ALTER FIELD |          |          |          |          | RESTART |          | NEXT MENU
  
```

4. a. Move the cursor to the PORT 4 CLASS field for the HP 2601A and the HP 2602A, to the PORT 5 CLASS field for all other printers.
- b. Press the ALTER FIELD softkey.
- c. Press the PRINTER softkey.
- d. Move the cursor to the TYPE field on the same line.
- e. Press the ALTER FIELD softkey.
- f. Press the softkey corresponding to the printer you are configuring.

<u>Printer</u>	<u>Type</u>	<u>Printer</u>	<u>Type</u>
HP 2601A	2601	HP 2932A	293x
HP 2602A	2602	HP 2933A	293x
HP 2631B	26xx	HP 2934A	293x
HP 2563A	2563	HP 82905B	905B
HP 2687A	2687		

- g. Press NEXT MENU to change the screen. Then press RECORD CONFIG. Press EXIT RFIG to return to the initial CONFIG screen.
5. If configuring an HP 2601A or HP 2602A printer, enter 2 to access the DROM EDIT function. Ensure that an X is entered next to the P2601 DROM entry. If not, press EDIT and enter 25 when asked which DROM to edit. If a blinking X appears, you must eliminate some other DROM to make room for the P2601 DROM. Press RECORD CONFIG and then press EXIT when the DROM is configured.
6. Press EXIT PROGRAM to leave CONFIG.
7. To use the new configuration, reload the system.

Printer System Test

1. Turn on the printer.
2. Press the "on line" button.
3. Reload the system (turn the key to 0 and back to 1 with the OPERATING SYSTEM disc in the drive)
4. After the cursor appears, type: RUN "TEST" then press the ENTER key.
5. a. Press the PRINTER TEST softkey.

SYSTEM TESTS
PRINTER TEST

PRINTER TEST - Tests the currently selected printer. Various options are available when testing each kind of printer.

SELECT PRINTER - Allows the printer to be tested to be specified.

CYCLE MODE - Toggles the cycle mode. If the cycle mode is ON, the PRINTER TEST will repeat forever.

Printer is currently CRT.
CYCLE MODE: OFF

Please select a function.

PRINTER TEST			SELECT PRINTER		CYCLE MODE	EXIT
--------------	--	--	----------------	--	------------	------

- b. After the screen changes, press the SELECT PRINTER softkey.

SYSTEM TESTS							
SELECT PRINTER							
SELECT CODE				DEVICE			
Printer is currently CRT. CYCLE MODE: OFF							
Please select a printer.							
TTY	26XX	2601	905B	2602	293X	MORE PRINTERS	EXIT

- c. Press the softkey corresponding to the printer you wish to test.
- d. Press PRINTER TEST.
- e. Press RIPPLE PRINT.
- f. After the printer prints about 50-100 lines, stop the printer by pressing EXIT. The printer may print a few lines before stopping.
- g. Press EXIT after the softkeys change.
- h. Either test another printer by going back to step b., or press EXIT again, then press EXIT PROGRAM.

Setting Up the HP 7220C/T and HP 7221C/T Plotters

Pen Installation

Load the pens by following these instructions:

1. Check that the LINE switch is off (set to 0).

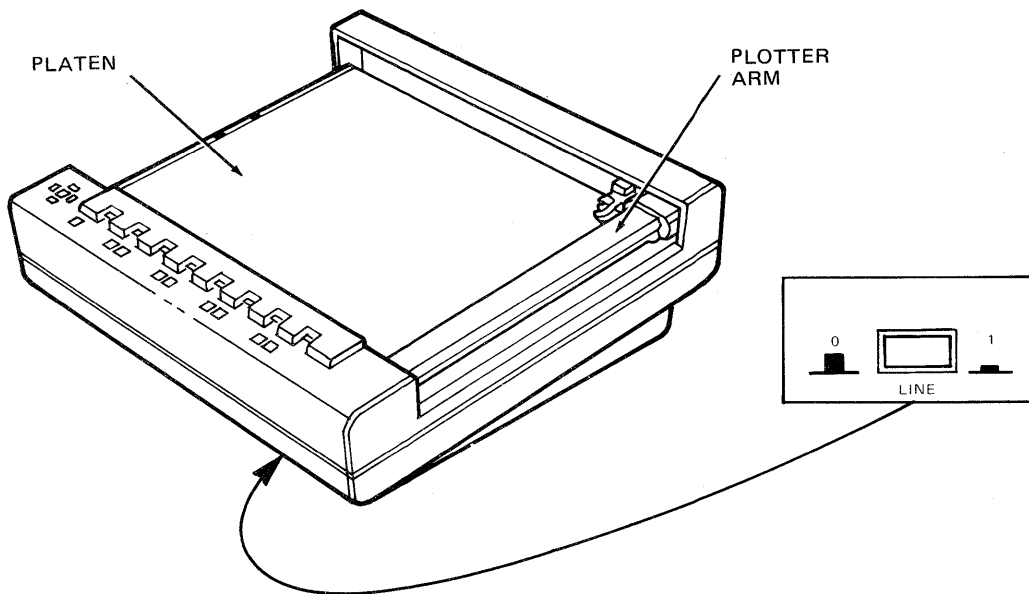

LINE Switch Location

2. Manually move the plotter arm to the right edge of the platen.
3. Select the pen (by color, type, or width) to be loaded in stall 1 of the pen stable, and remove the pen cap.

Installation

4. Insert the tip of the pen into the rubber cap located at the bottom of the pen stall as shown below.

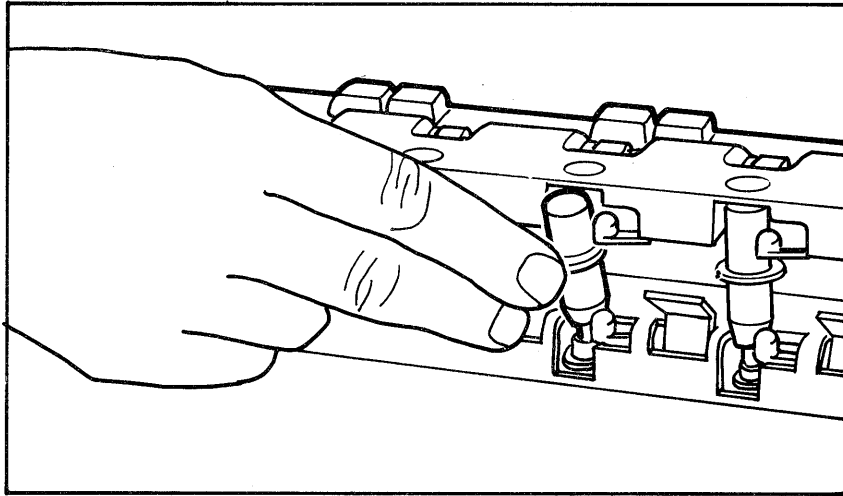

Pen Stable Loading

5. Push the pen into the stall by exerting slight downward and forward pressure on the top of the pen.
6. Repeat the previous procedures until the eight pen stalls are full.

7. Check that the power cord is connected and press the LINE switch "ON."

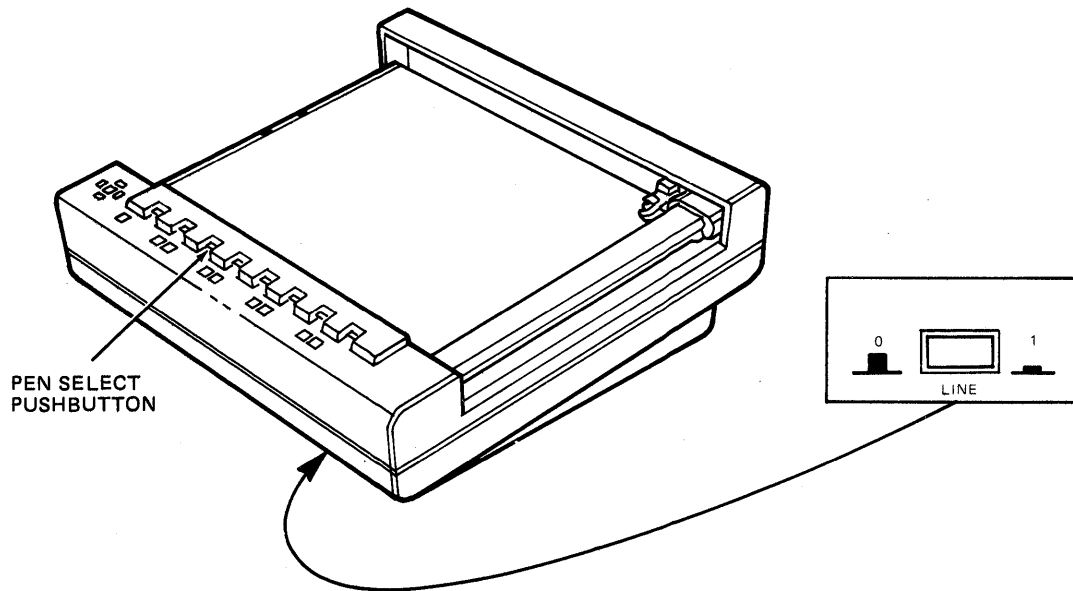

LINE Switch Location

8. Load the pen holder by pressing the Pen Select pushbutton associated with the pen to be used.

Loading Sheet Paper

(NOTE: For installation and testing, load the plotters (including the HP 7220T and HP 7221T) with the large sized paper provided with your plotter. Instructions for loading roll paper are in the plotter Operator Manuals.)

Load sheet paper as follows:

1. Raise the paper stop by pushing down the upper portion of the stop with a pencil or pointed object.
2. Press CHART LOAD. The CHART LOAD and OUT OF LIMIT lamps should go on steady and the pen holder is moved to the upper right corner of the platen.
3. Place sheet paper on platen so that the lower edge is under the lips of the nylon paper stops, then move paper to the left so that the paper is snug against the left paper stop.

Installation

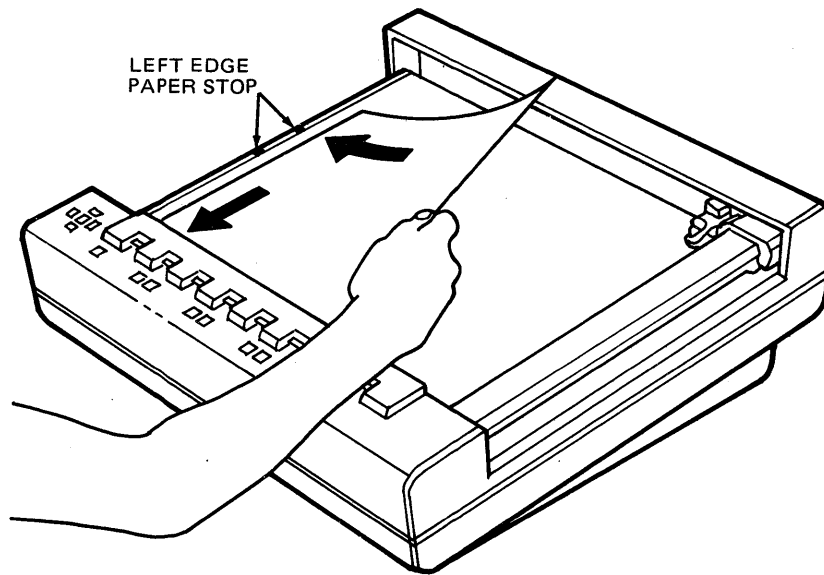

Loading Sheet Paper

4. Press the CHART HOLD pushbutton. The CHART LOAD lamp should go out and the OUT OF LIMIT lamp should stay on steady. Smooth the paper with left-to-right motion with the back of your hand.

The Plotter Confidence Test

1. Push the LINE switch off.
2. Connect the RS-232-C cable supplied with the plotter to the rear-panel TERMINAL and MODEM connectors as shown below.

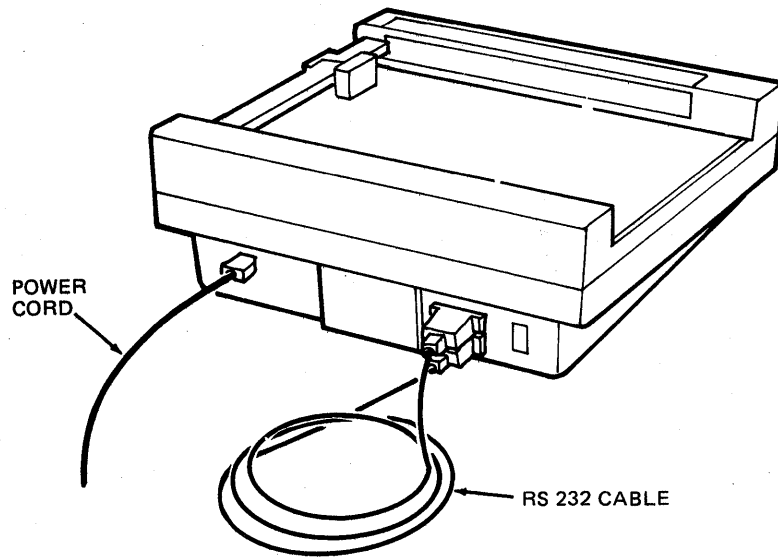

Plotter Confidence Test Connections

Installation

3. Set rear panel switch settings as follows:

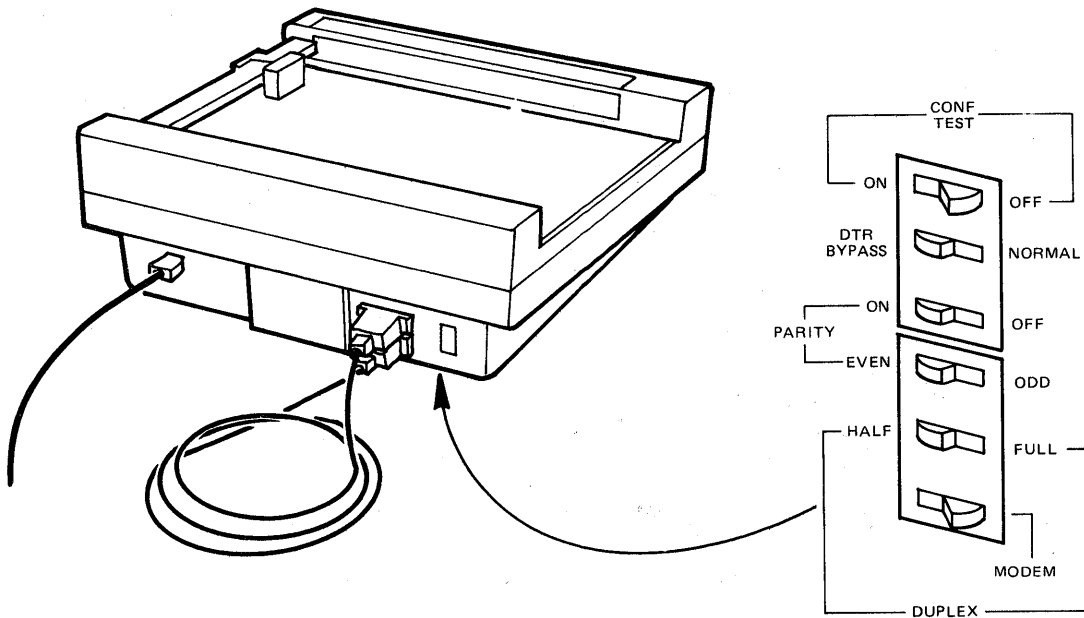

HP 7220 C/T and HP 7221 C/T Plotter Switch Settings (Rear Panel) Plotter Confidence Test Only

4. Push the LINE switch on. The plotter performs an initialization sequence, then the confidence test runs and performs the following functions in sequence:
 - a. OUT OF LIMIT, ON LINE, and DATA SET lamps glow steadily.
 - b. The plotting pen moves to the lower right corner of the platen then moves to the lower left corner.
 - c. ON LINE lamp turns off.
 - d. STBY lamp turns on steady.
 - e. DATA SET lamp flashes 3 times.
 - f. The plotter performs a self-test of various internal circuits. During this time the plotting pen does not move. This part of the test takes approximately 3 seconds.
 - g. The plotter executes the confidence test plot.

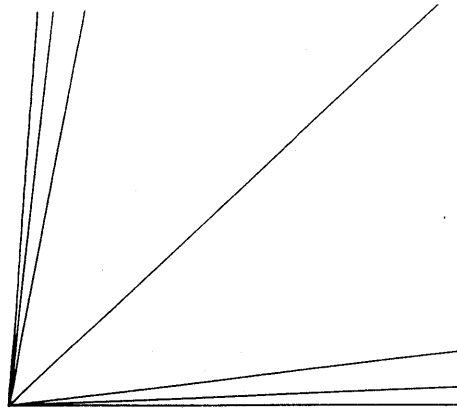

Confidence Test Plot

- h. The plotting pen returns to the lower left corner of the platen with the pen down.
- i. The following lamps go on steady: ENTER, OUT OF LIMIT, ERROR, CHART LOAD, ON LINE, and LOCAL.
- j. The DATA SET and STBY lamps are off.

NOTE

If a failure occurs while the confidence test is running, or if improper results are obtained, refer the problem to qualified service personnel.

This concludes the confidence test.

Set the LINE (lower front panel) and CONF TEST (rear panel) switch off. Disconnect the RS-232-C cable from the TERMINAL and MODEM connectors.

Connecting the Plotter to the Mainframe

1. When the self-test is complete, turn off the plotter and the mainframe.
2. Connect the RS-232-C cable to the back panel of the plotter at the port labelled MODEM or SIGNAL INTERFACE. Connect it to Port 3 on the mainframe.
3. Set the switches on the plotter's rear panel as follows:

Installation

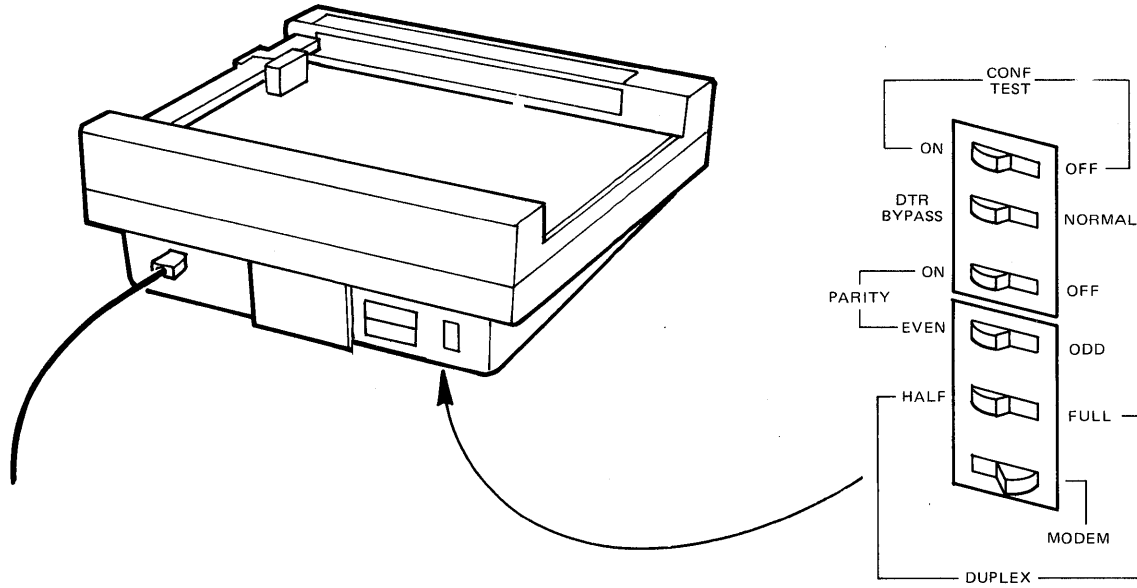

HP 7220 C/T and HP 7221 C/T Plotter Rear Panel
Switch Settings - Standard Use

4. Turn off the system.
5. Configure the plotter (plotter CONFIG instructions follow the HP 7470A installation instructions).

Setting Up the HP 7225 Plotter

Power-Up Initialization

Turn on the plotter by pressing the LINE button "ON."

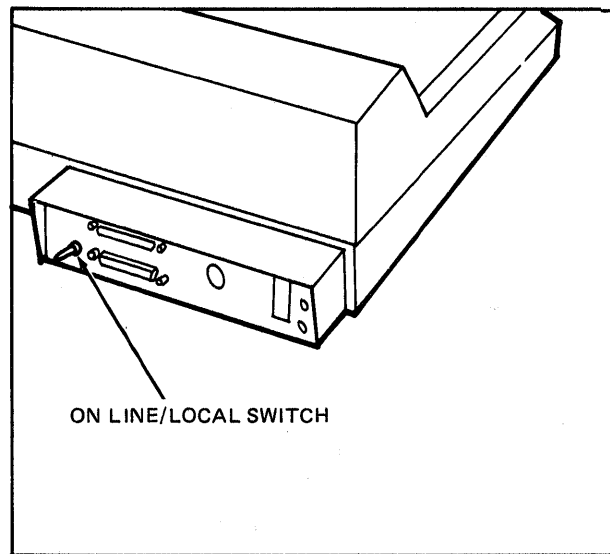

LINE Switch Location

The following should occur:

- a. Pen moves to upper right corner and remains raised.
- b. Electrostatic hold-down is activated.

Loading the Pen

After the plotter's initialization process is complete and the plotter arm has stopped moving, install the pen. Install it by holding the metal carrier ring up with one hand while pressing the pen into the holder with the other hand.

Installation

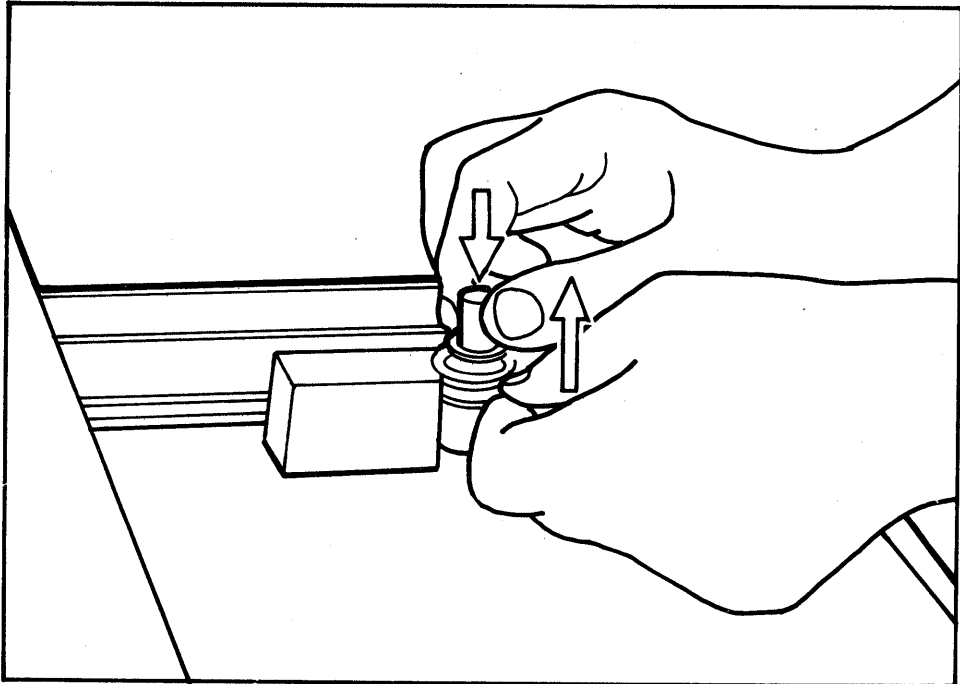

Installing The Pen

Loading Paper

1. To load paper, first press CHART LOAD.
2. Lay a sheet of plotter paper (supplied with the plotter) on the platen surface and smooth out with the back of your hand. Make sure the paper is positioned squarely against the ridge at the bottom of the platen. Now press the CHART HOLD button.

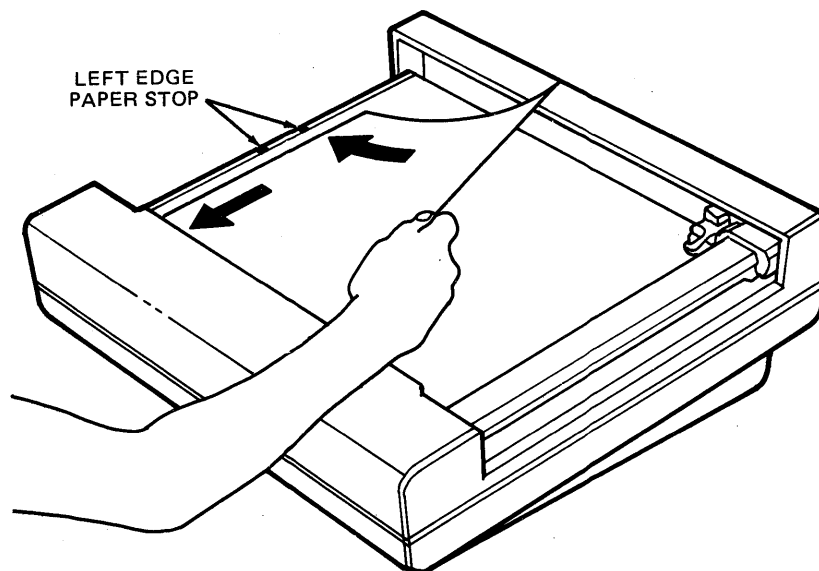

Loading Sheet Paper

3. Turn the ON LINE switch off.

Installation

4. Set the switches on the plotter's rear panel as follows:

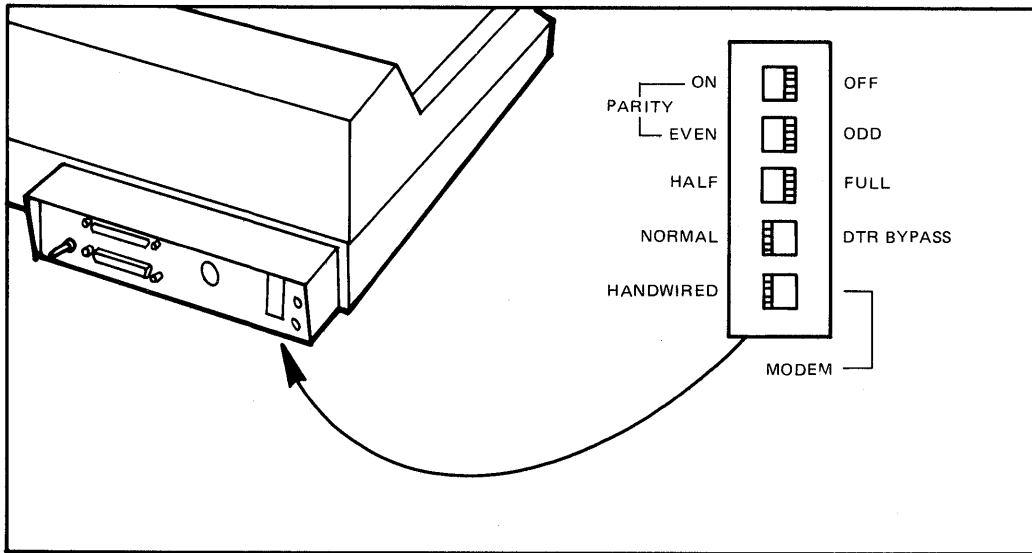

HP 7225 Plotter Switch Settings (Rear Panel)

Now you are ready to do the self-test.

Running the Confidence Test

The confidence test can be performed with the personality module installed or removed. If the module is installed and functioning properly, the fan pattern and the words END OF TEST are drawn. If the module is removed only the fan pattern is drawn. If the personality module is malfunctioning, the words END OF TEST will not be drawn or will be incomplete depending upon the nature of the malfunction.

END OF TEST

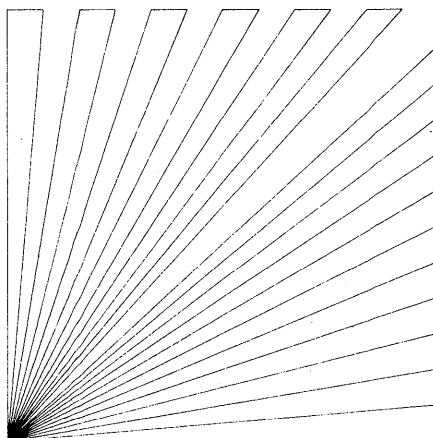

Confidence Test Plot

If the fan pattern is incorrect only when the personality module is installed, the module is malfunctioning. If after the module is removed, the fan pattern is still incorrect, the malfunction is in the plotter. In either case, a Hewlett-Packard sales and service office should be contacted.

The confidence test is performed in this way:

1. Press the LINE switch ON. The plotter performs a power-up initialization sequence. If the personality module is not installed, the ERROR and OUT OF LIMIT lamps will be on steady.
2. Press the CONFIDENCE TEST pushbutton on the rear panel. The CHART LOAD, ENTER, ERROR, and OUT OF LIMIT lamps light momentarily (if the personality module is installed); the pen moves to the upper right mechanical limits; then, the confidence test plot is drawn. If the personality module is not installed, the ERROR and OUT OF LIMIT lamps stay on steady and the words END OF TEST are not drawn.

Connecting the Plotter to the Mainframe

1. When the self-test is complete, turn off the plotter and the mainframe.
2. Connect the RS-232-C cable (supplied) to the plotter rear panel at the port labelled MODEM, then connect it to Port 3 on the mainframe.

Installation

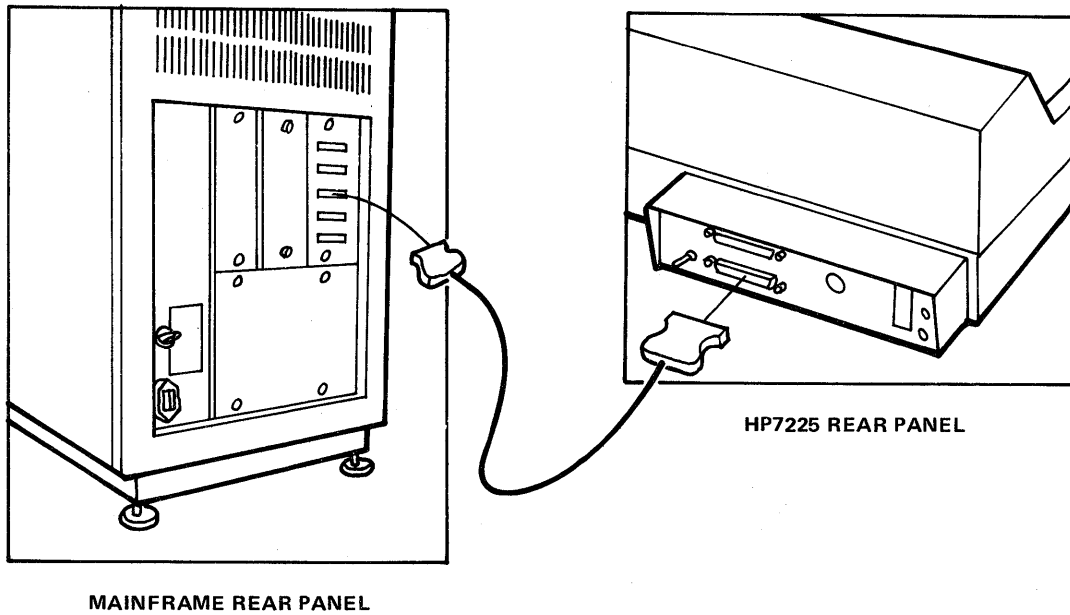

Plotter Connection to Mainframe

3. Set the switches on the plotter's rear panel as follows:

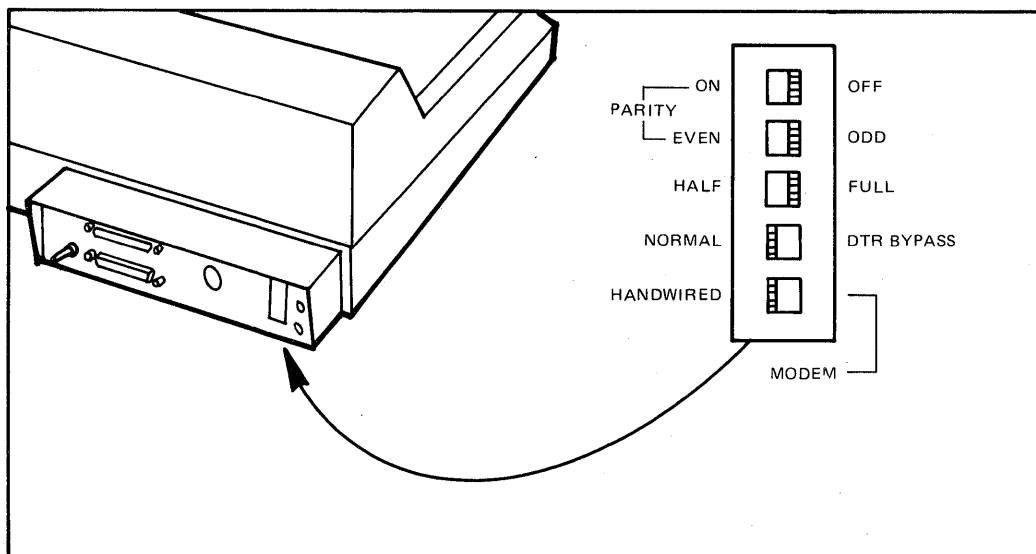

HP 7225 Switch Settings (Rear Panel)

4. Turn the key on the system from 0 to 1.
5. Configure the plotter (CONFIG instructions follow the the HP 7470A installation instructions).

HP 7470A Plotter Installation

Connect AC Power

The HP 7470A plotter is normally shipped with a power cable suited to your country. Consult the HP 7470A Operator's Manual (Manual Part No. 07470-90002) for more details.

Plotter Self Test

The Plotter Self Test verifies the mechanical and electronic integrity of the HP 7470A, independent of its connection to the HP 250 Computer System. It is performed as follows:

1. With AC power OFF, load pens and paper.
2. Turn on the AC power while pressing the PEN UP button.
 - a. The plotter goes through an initialization cycle.
 - b. After initialization, the plotter self-test cycle begins and lasts approximately 55 seconds:
 1. The plotter will select alternate pens, moving between scaling points P1 and P2.
 2. It will draw an asterisk with pen 2 and move 79 spaces along the X axis. 3. Pen 2 will be stored and the holder will return to P1, indicating that the test is completed.
 - c. If the asterisk is drawn, there is a high probability that the plotter is functioning properly.
 - d. The confidence test cycle repeats every 55 seconds, placing asterisks at different locations on the page. There is little need to continue testing after the first asterisk is plotted. There is a long quiet period between test cycles.
 - e. To stop the confidence test, turn off power to the plotter.

Physical Connection to System

Physical connection consists of four operations:

1. SET PLOTTER BACK PANEL SWITCHES

PARITY S1 - Set to 0 (this disables parity checking).

PARITY S2 - Doesn't matter with S1 set to "0".

D/Y - Position D indicates that the plotter is connected directly to the computer.

Installation

US/A4 - Set this rocker switch on US for 8.5 x 11 inch paper and 7470A Overhead Transparency Film; on A4 for 210 x 297 millimeter paper.

B4/B3/B2/B1 - Set these four rocker switches as follows:

B4	B3	B2	B1
--	--	--	--
1	0	0	0

2. CONNECT PLOTTER TO PORT 3 ON THE SYSTEM BACK PANEL.

The recommended cable, which must be ordered separately from the plotter, is HP Part No. 8120-3258, a three-meter RS-232-C cable. This same cable can be used to connect the HP 7220, HP 7221, or HP 7225 Plotters to the HP 250 Computer System.

CONFIGuring Plotters

1. After you load the system and the cursor appears, type: RUN "CONFIG"
2. After the initial CONFIG menu appears, enter 9 for the Remote I/O screen.
3. Use the cursor control keys to move the cursor to the PORT 3 CLASS field.
4. Press ALTER FIELD until TERMINAL appears.
5. Move the cursor to the TYPE field on the same line.
6. Press ALTER FIELD until 26xx appears.
7. The FORMAT on PORT 3 is 8N1. If it is not, move the cursor to that field, press ALTER FIELD, and select the key labelled 8N1.
8. When you finish editing this Remote I/O screen, press the NEXT MENU softkey and note that the softkey labels change.
9. Press RECORD CONFIG. The following message appears briefly: "System is busy recording remote I/O configuration onto system disc."
10. Press EXIT RFIG to return to the initial CONFIG menu.
11. When you return to the initial CONFIG menu, enter 8 to select Memory Configuration.
12. After the "MEMORY CONFIGURATION" screen appears, press the ACTUAL CONFIG softkey.
13. Check the table at the center of the screen. The headings are "BLOCK," "Lower," and "Upper."
 - a. If "YES" appears in both the "Upper" and "Lower" columns for any block number besides 01, 02, or 03, go to step 14 in this section.
 - b. If "YES" does not appear in both the "Upper" and "Lower" columns for any block number except 01, 02, or 03, call your Sales Representative or OEM. Your HP 250 system does not have enough memory to run the plotter and the graphics software. You may purchase additional memory. You may use the rest of your system, so proceed with these instructions until you exit the CONFIG program.
14. On the "MEMORY CONFIGURATION" screen after you press ACTUAL CONFIG, press the NEXT MENU softkey.
15. After the softkey labels change, press RECORD CONFIG then EXIT MFIG.

Installation

16. When the screen changes again, enter 2 to access the DROM EDIT function. You need the following DROMs:

PACK
TIO

If you will be using DSG/250, you will also need:

FORMS
TRIG

Be sure there is an X next to the DROMs that you need. If not, press EDIT and enter the number of the DROM you wish to load. When all of the DROMs desired are configured, press RECORD CONFIG. Then press EXIT to return to the main CONFIG menu.

17. When the screen changes again, press EXIT PROGRAM.
18. Reload the system (turn the key to 0 and back to 1 with the SYSTEM disc in the drive)
19. a. Type: RUN "TEST" ,then press the ENTER key.

- b. When the screen changes, press the PLOTTER TEST softkey.

- c. If plotter model numbers appear in the softkey labels, press the appropriate key and go to step e.

If the desired model number does not appear, press EDIT GPL%CF. If no plotter model numbers appear, press CREATE GPL%CF. In both cases, you will be asked to select a plotter model number and address. (The address is 13.)

- d. Press the appropriate softkeys to select your model and model type.

- e. Press 13 for the plotter's address.

- f. When the softkeys change again, select the SIMPLE test.

- g. Enter the date using either of the following forms: mm/dd/yy or dd.mm.yy.

- h. When the run number is requested, press the ENTER key.

- i. For the paper selection, press ENGLISH or METRIC to correspond with the paper you are using.

- j. Use either small or large plotter paper; select the appropriate PAPER SIZE softkey.

- k. When the screen changes, verify the information on the screen, then press START PLOTTING.

1. After the test is complete, press EXIT PROGRAM to leave the test procedure.

Additional Workstations

Follow the same installation instructions you used for the first workstation. Additional workstations are connected to port 2 (also, 6 and 7, if you have the option ports, 6-10).

If you connect your additional workstation to the mainframe with current loop, you must set the port switches on the rear panel of the mainframe.

To set the switches:

1. Remove the door covering the switches by pulling the black knobs toward you.

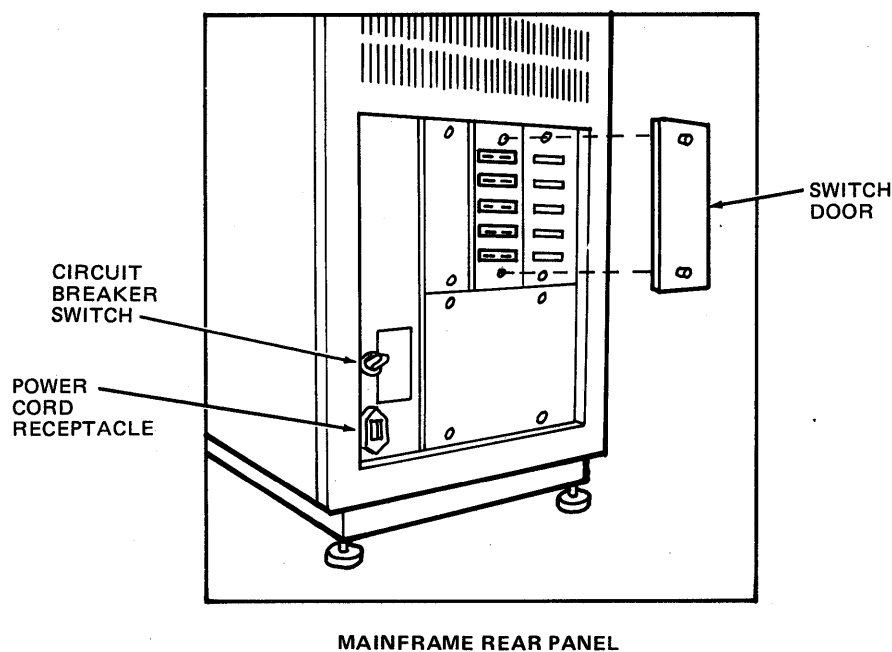

Mainframe Rear Panel Configuration Switches

2. Locate the set(s) of switches corresponding to the current loop port. Each set of 2 switch panels correspond to the port beside it as described on the legend at the left of the switch door. (Ports 1-5 are on the upper panel and the optional ports, 6 through 10 are on the lower panel.)
3. For each current loop port, set the switches for a Current Loop Port as described inside the cover panel.

Installation

When you run CONFIG for additional workstations, position the cursor in the row corresponding to that workstation's port.

Give the additional workstation 32K memory for now. Remember to press NEXT MENU then RECORD CONFIG before you exit the CONFIG program.

Reload the system after running CONFIG.

HP 3075A, 3076A, AND 3077A DATA CAPTURE TERMINAL INSTALLATION

1. Turn off the HP 250 by turning the key to the 0 position.
2. Place the terminal on a table or work surface near the mainframe. Do not place it on the mainframe, box, or other peripheral.
3. Make sure the terminal LINE switch is OFF.
4. Connect the power cord to the terminal, then to the wall outlet.
5. Connect the RS-232C interface cable to the terminal, then to port 2 on the HP 250.

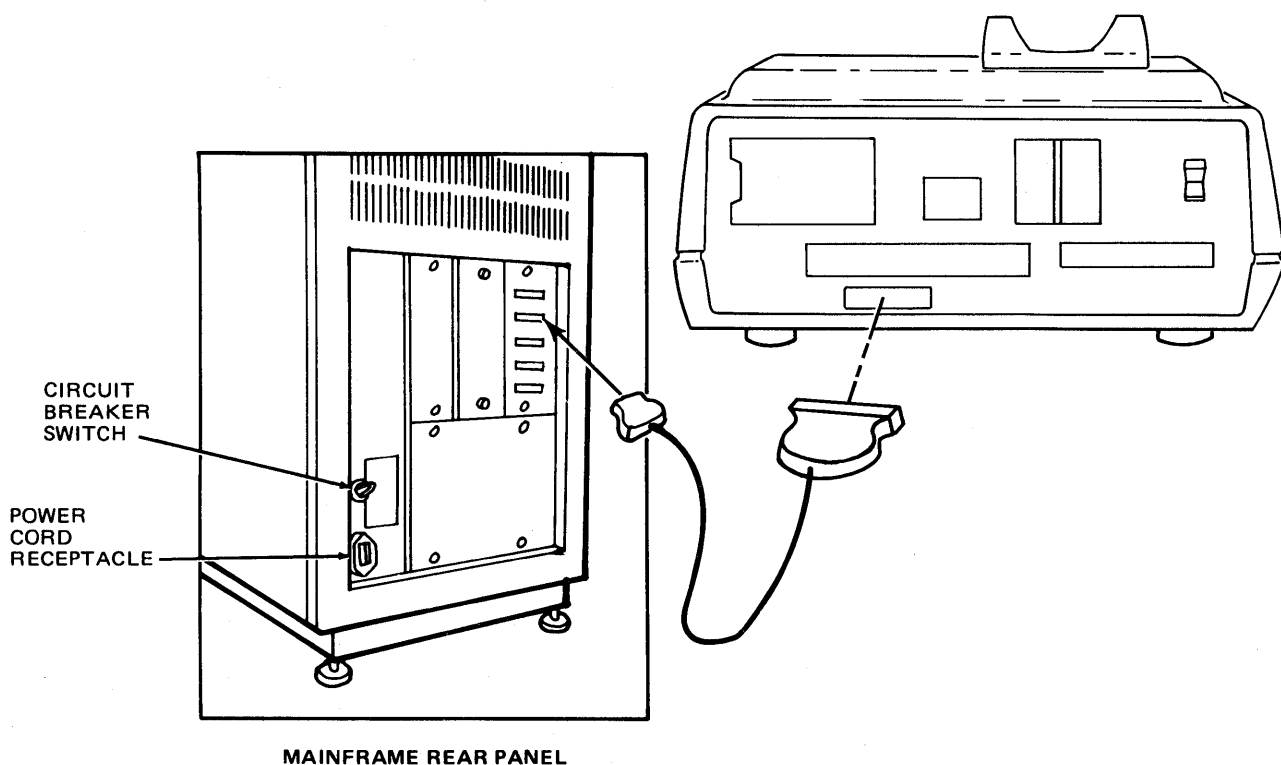

6. For each unused port, set the switches for an Unused Port as described on the inside of the switch door.
7. Set the configuration switches for the terminal testing and perform the test. (Refer to the data capture terminals reference manual for instructions on testing.)

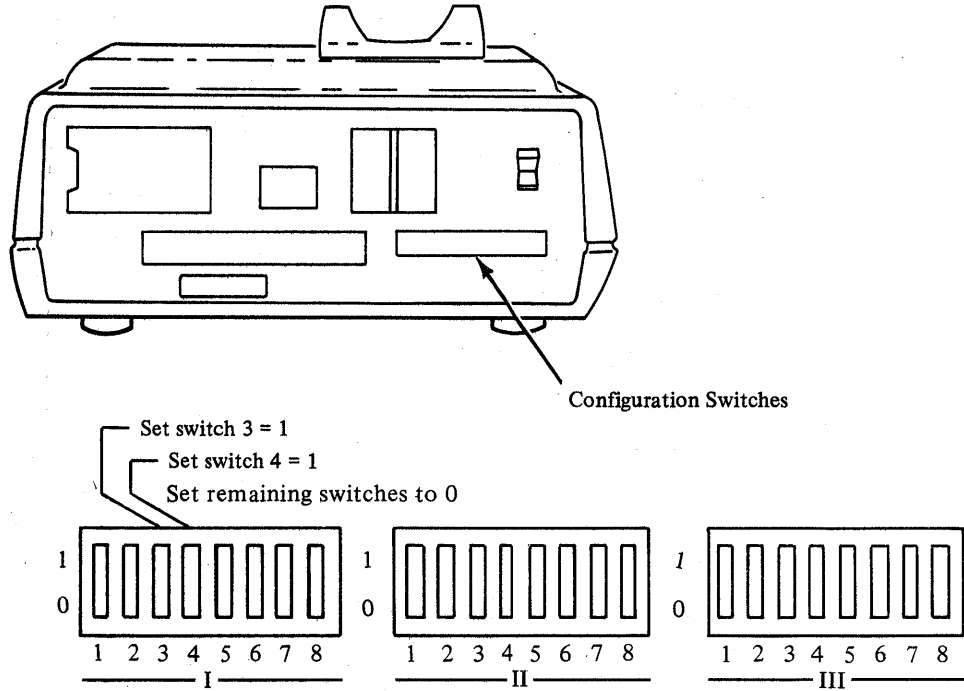

HP 3075A/3076A Terminal Configuration Switch Settings For Normal Operation

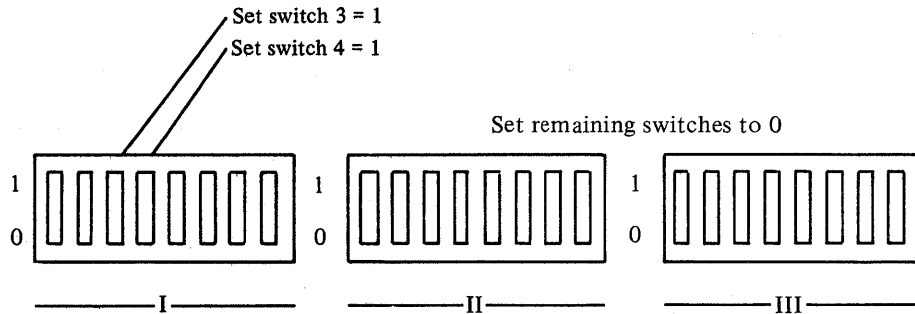

HP 3077A Terminal Configuration Switch Settings For Normal Operation

8. After you load the system and the cursor appears, type:
RUN "CONFIG"
9. After the initial CONFIG menu appears, enter 9 for the remote I/O screen.
10. Use the cursor control keys to move the cursor to the PORT 2 CLASS field.
11. Press ALTER FIELD until TERMINAL appears.
12. Move the cursor to the TYPE field on the same line.
13. Press the ALTER FIELD until 26xx appears.
14. The format on PORT 2 is 701. If it is not, move the cursor to that field, press ALTER FIELD, and select the key labeled 701.
15. When you finish editing this Remote I/O screen, press the NEXT MENU softkey and note that the softkey labels change.
16. Press RECORD CONFIG. The following message appears briefly:
"system is busy recording remote I/O configuration onto system disc".
17. Press EXIT RFIG to return to the initial CONFIG menu.
18. When the screen changes, enter 2 to access the DROM EDIT function.
You need the TIO DROM.

Be sure there is an X next to the TIO DROM. If not, press EDIT and enter the number of the TIO DROM. When the TIO DROM is configured, press RECORD CONFIG and then press EXIT to return to the main CONFIG menu.
19. When the screen changes again, press EXIT PROGRAM.

HP 3081A Data Capture Terminal Installation

NOTE

The HP 3081A must be connected to an HP 92922A 4-Channel Adapter which, in turn, is connected to the HP 250.

1. Turn off the HP 250 by turning the key to the 0 position.
2. Place the terminal and adapter on a table or work surface near the mainframe. Do not place them on the mainframe, box, or other peripheral.
3. Using the current loop cable (the one with 12-pin connectors), connect one end to the terminal and the other end to the channel 1. This is the right-most receptacle on the lower row of receptacles.
4. Connect the RS-232-C interface cable to channel 1 of the adapter. This is right-most receptacle on the upper row of receptacles.
5. Connect the free end of the interface cable to port 2 of the HP 250.
6. Turn the HP 250 power on by turning the key to the 1 position.
7. Connect the power cord to the adapter, then to the wall outlet. The terminal performs a self-test for approximately 0.5 second, after which time, a successful test will cause the terminal beeper to sound once and the cursor will blink.

Upon completion of the sequence, the display is cleared and the terminal is ready.

8. After you load the system and the cursor appears, type:
RUN "CONFIG"
9. After the initial CONFIG menu appears, enter 9 for the remote I/O screen.
10. Use the cursor control keys to move the cursor to the PORT 2 CLASS field.
11. Press ALTER FIELD until TERMINAL appears.
12. Move the cursor to the TYPE field on the same line.
13. Press the ALTER FIELD until 26xx appears.
14. The format on PORT 2 is 701. If it is not, move the cursor to that field, press ALTER FIELD, and select the key labeled 701.
15. When you finish editing this Remote I/O screen, press the NEXT MENU softkey and note that the softkey labels change.
16. Press RECORD CONFIG. The following message appears briefly:
"system is busy recording remote I/O configuration onto system disc".
17. Press EXIT RFIG to return to the initial CONFIG menu.
18. When the screen changes, enter 2 to access the DROM EDIT function.
You need the TIO DROM.

Be sure there is an X next to the TIO DROM. If not, press EDIT and enter the number of the TIO DROM. When the TIO DROM is configured, press RECORD CONFIG and then press EXIT to return to the main CONFIG menu.

19. When the screen changes again, press EXIT PROGRAM.

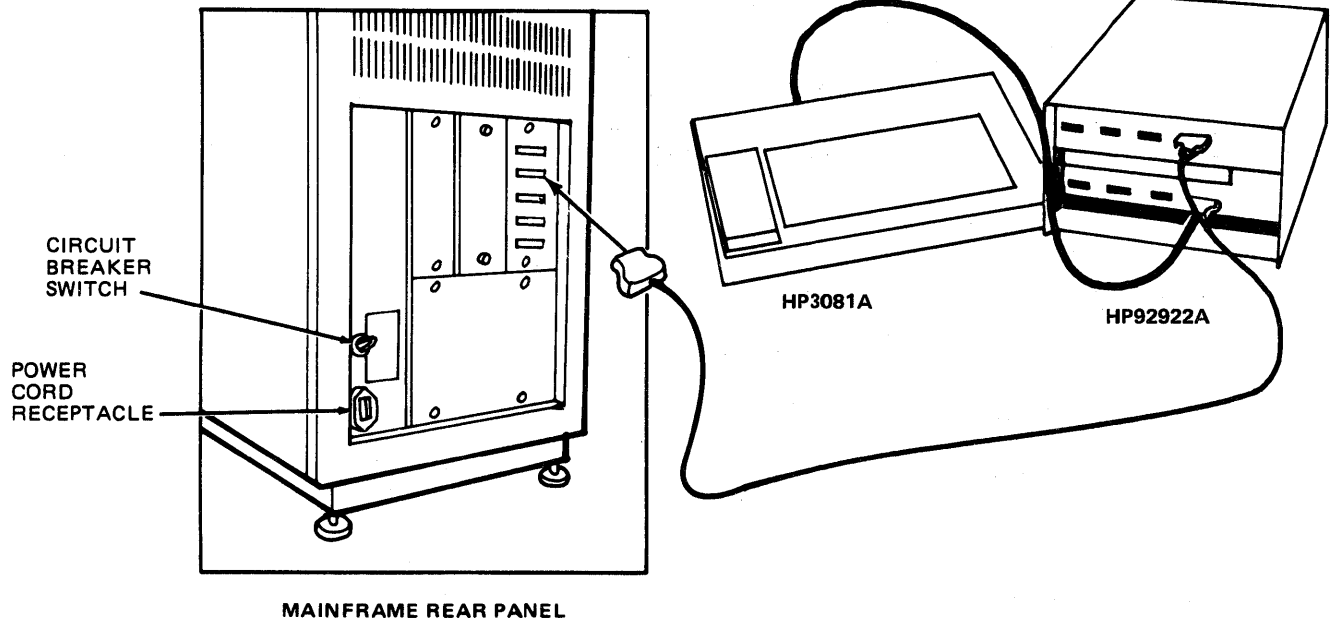

HP 39800A BAR CODE READER INSTALLATION

1. Turn off the HP 250 by turning the key to the 0 position.
2. Place the bar code reader on a table or work surface near the mainframe. Do not place it on the mainframe, box, or other peripheral.
3. Make sure the bar code reader power switch is off.
4. Orient the plug on the wand cord so the screw on plug is facing down, and plug it into the receptacle on the front of the reader. Turn its locking ring clockwise to secure it.
5. Connect the power cord to the reader, then to the wall outlet.
6. Set the switches on the back of the reader as follows:

BAUD RATE: 9600 baud	Switch 0: 0
	1: 1
	2: 1
PARITY: Odd	Switch 3: 1
	4: 1
STOP BITS: 1	Switch 5: 0
CHARACTER DELAY: Disable	Switch 6: 0
SOFTWARE HANDSHAKE: Standalone mode ENQ/ACK	Switch 7: 1
	8: 1
MODE: Character	Switch 9: 0
LOCAL ECHO: Disable	Switch 10: 0
TERMINATOR: CR	Switch 11: 0
	12: 0
BLOCK MODE TERMINATOR: None	Switch 13: 0

7. Perform the reader self-test and wand test. The bar code is located on the bottom of the reader, and is reproduced here and at the back of the HP 39800A Bar Code Reader Operating and Installation Manual.



TEST PROCEDURE

The following test procedure will confirm that the bar code reader is functioning properly.

1. Turn the reader off.
2. Write down the switch positions for switches 8 and 14 through 17.
3. Set switches 8 and 14 through 17 in the positions indicated below.

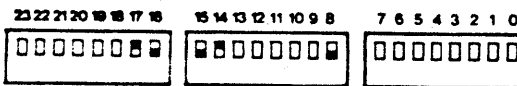

NOTE: The settings of the remaining switches should not be changed.

4. Turn reader on. The beeper will sound when the internal self-test has been successfully completed.
5. Scan the bar code below. The beeper will sound after the reader successfully reads the bar code.



TEST OK

6. Test complete. Contact the local Hewlett-Packard sales and service office if the beeper does not sound in steps 4 and 5.
7. If test is satisfactory, return the switches to their original positions as follows:
 - A. Turn reader off.
 - B. Return switches to the original position noted in step 2.
 - C. Turn reader on.

NOTE: The reader may require reprogramming after completion of the test.

Installation

8. Connect the RS-232-C interface cable to the reader, then to port 5 on the HP 250.

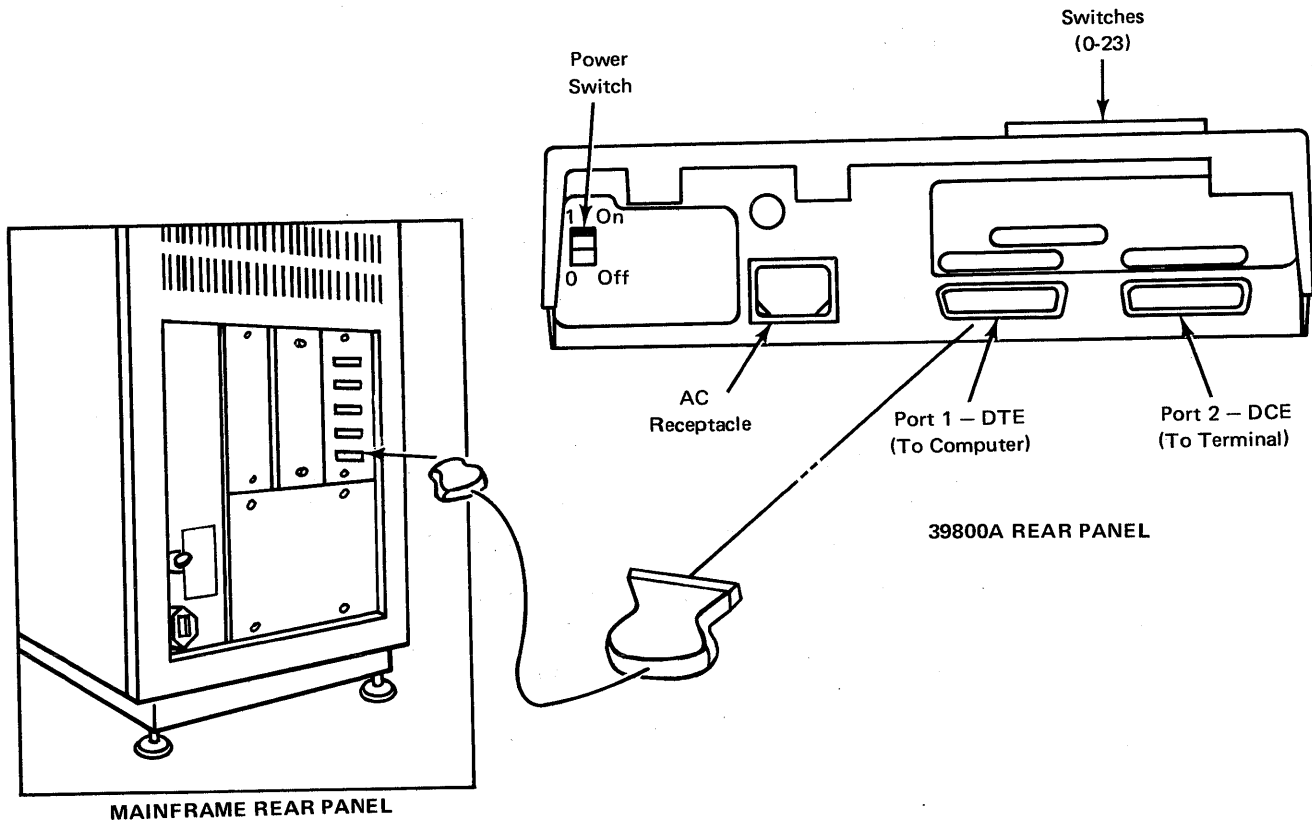

9. After you load the system and the cursor appears, type:
RUN "CONFIG"
10. After the initial CONFIG menu appears, enter 9 for the remote I/O screen.
11. Use the cursor control keys to move the cursor to the PORT 5 CLASS field.
12. Press ALTER FIELD until TERMINAL appears.
13. Move the cursor to the TYPE field on the same line.
14. Press the ALTER FIELD until 26xx appears.

15. The format on PORT 5 is 701. If it is not, move the cursor to that field, press ALTER FIELD, and select the key labeled 701.
16. When you finish editing this Remote I/O screen, press the NEXT MENU softkey and note that the softkey labels change.
17. Press RECORD CONFIG. The following message appears briefly:
"system is busy recording remote I/O configuration onto system disc".
18. Press EXIT RFIG to return to the initial CONFIG menu.
19. When the screen changes, enter 2 to access the DROM EDIT function. you need the TIO DROM.

Be sure there is an X next to the TIO DROM. If not, press EDIT and enter the number of the TIO DROM. When the TIO DROM is configured, press RECORD CONFIG and then press EXIT to return to the main CONFIG menu.

20. When the screen changes again, press EXIT PROGRAM.

After All Peripherals are Installed

The final installation step is to set some switches on the back panel of the computer. These settings will indicate that some ports are not in use, and will prevent electrical interference through those ports.

To set the switches:

1. Remove the door covering the switches by pulling the black knobs toward you.

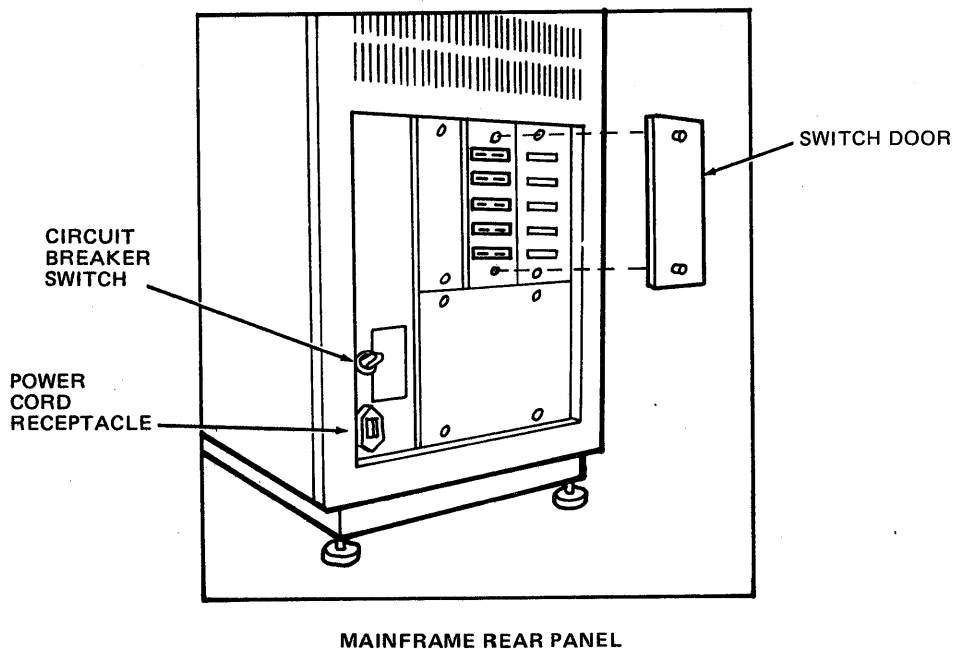

Mainframe Rear Panel Configuration Switches

2. Locate the set(s) of switches corresponding to the unused port(s). Each set of two switch panels corresponds to the port beside it as described on the legend at the left of the switch door. (Ports 1-5 are on the upper panel and the optional ports, 6-10 are on the lower panel.)

3. For each unused port, set the switches for an Unused Port as described on the inside of the switch door.

Installation

Once you have finished setting the switches on the unused ports, write the switch settings on the legend and put a mark in the appropriate column above the port numbers. Don't forget to have your electrician measure the neutral-ground and ground-ground voltages (not to exceed 4V p-p) with your system running. (See the Site Preparation chapter in this manual for more details.)

Conclusion

Now that you have installed your system, it is time to get to know your HP 250. The manuals provided with the system contain valuable information about your computer. Below is a brief overview of the manuals in the order you may want to use them.

Operating the HP 250 -- contains information about starting up your computer operations, workstations, printers, plotters, and your HP 250 system. (part no. 45260-90002)

Managing Your HP 250 -- contains helpful information about organizing your computer operations. (part no. 45260-90003)

System Utilities Manual -- contains instructions for setting up system defaults with the Utilities Programs. (part no. 45260-90061)

QUERY/250 Operator's Guide -- provides information about your HP 250 Data Base system and the data entry forms features of the HP 250. (part no. 45251-90005)

Even though you may not use this manual in the near future, save it in case you move or add to your system.

APPENDIX A

Space Planning Kit

HP 250 Space Planning Kit

The top views of the system components are drawn to scale and can be used for designing the floor plan of your HP 250. When cut out and used on a scale drawing of your computer site, the models can be moved about to help determine the best room arrangement. The next page is a sheet of grid paper drawn to the same scale. It can be used to prepare the scale drawing of your proposed HP 250 site.

Instructions

1. On the grid sheet, draw the room (walls, electrical outlets, immovable objects, etc.) in which you plan to locate the HP 250. The grid is drawn to the scale of $\frac{1}{4}$ inch = 12 inches (6.35 mm = 304.8 mm).
2. Cut out the models required to represent the HP 250 system that you ordered. Include the office furniture that you will use.
3. Move the models of your system about on the grid to determine the best room arrangement. (Don't forget to allow room for maintenance in front and back of system and disc[s].)
4. Cabling is required between the HP 250 and each peripheral. Mark each cable's path and indicate its necessary length.

Space Planning Grid Sheet

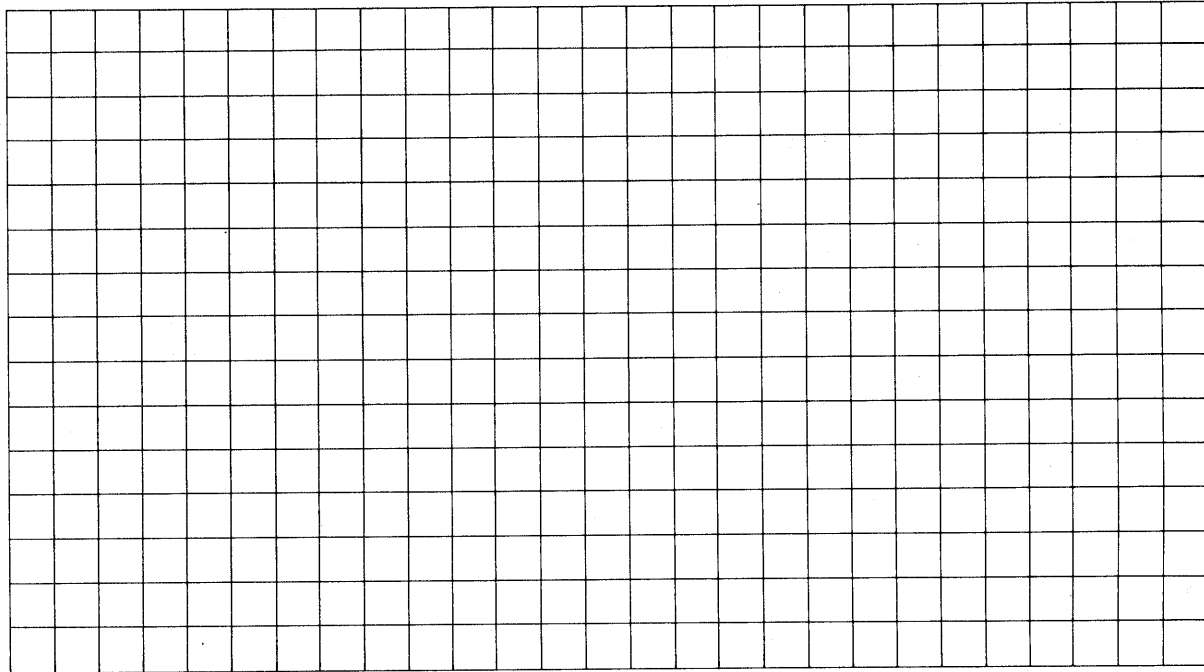

($\frac{1}{4}$ in. = 1 ft.)

(6.35 mm = 304.8 mm)

Cut out the models required to represent the HP 250 system that you ordered. Include the office furniture that you will use.

HP 250
Model 20/25
with
Workstation
Table

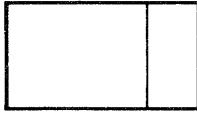

HP 2631B
Printer



HP 250
Model 20/25
with
Workstation
Table

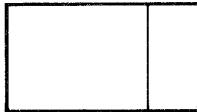

HP 2631B
Printer

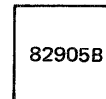
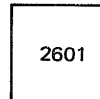

39800

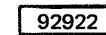
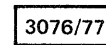

APPENDIX B

Electrical Specifications

This appendix contains the information required by your electrician for preparing your computer site. You and your electrician should read over both this appendix and all of the electrical discussions in Chapter 2.

HP 250 Model 20 and 25 Power Specifications

One of the most important considerations is the system electrical power requirements. Model 20/25 power requirements are:

- o Line voltage Single Phase 100/120/220/240V, +5%-10%.

Nominal	Range
100	90 to 105
120	108 to 126
220	198 to 231
240	216 to 252

- o Line frequency 50 Hz or 60 Hz, +-3.5%

- o Safety ground Required protection of operating personnel.

- o Separate circuit breakers (suggested) Available current cannot exceed 75% of circuit breaker rating.

- o Power line transients Power transients and interference less than specified value for Model 20/25 (See Figure B-1)

- o Neutral-ground and ground-ground voltage Less than 4.0 volts p-p at each outlet with system components installed and powered on.

Electrical Specifications

Table B-1. Power Requirement Calculations

EQUIPMENT	AMPERAGE DRAWN (DEPENDS UPON LOCAL VOLTAGE)				MULTIPLY BY NUMBER OF MACHINES	TOTAL MACHINE AMPERAGE
	100V	120V	220V	240V		
MODEL 20/25 (WITH 2622D)	3.7	3.1	1.6	1.5		
2601A	1.6	1.3	0.8	0.7		
2602A	1.0	0.9	0.5	0.5		
2631B	1.8	1.5	0.8	0.7		
2563A	6.0	5.0	2.7	2.5		
2687A	8.4	7.0	3.82	3.5		
2932A	3.0	2.5	1.36	1.25		
2933A	3.0	2.5	1.36	1.25		
2934A	3.0	2.5	1.36	1.25		
2622D	1.2	1.0	0.5	0.5		
7220C/T	1.3	1.1	0.6	0.6		
7221C/T	1.3	1.1	0.6	0.6		
7225B	1.0	1.0	0.5	0.5		
7470A	0.3	0.2	0.1	0.1		
82905B	1.0	0.8	0.4	0.4		
3075A	0.9	0.75	0.41	0.375		
3076A	0.9	0.75	0.41	0.375		
3077A	0.9	0.75	0.41	0.375		
3081A with 92922A	0.6	0.5	0.27	0.25		
39800A	0.24	0.2	0.11	0.1		
HP250 COMPUTER SYSTEM TOTAL AMPERAGE =						
PLUS 35% FOR STARTUP AND SURGE CURRENT =						
TOTAL AMPERAGE WITH PROTECTION =						

Where multiple circuits are needed to provide the required total amperage protection, consult local electrical codes to determine the appropriate circuit breaker sizes and load distribution (maximum breaker in the United States is 20 Amps; in Canada, 15 Amps).

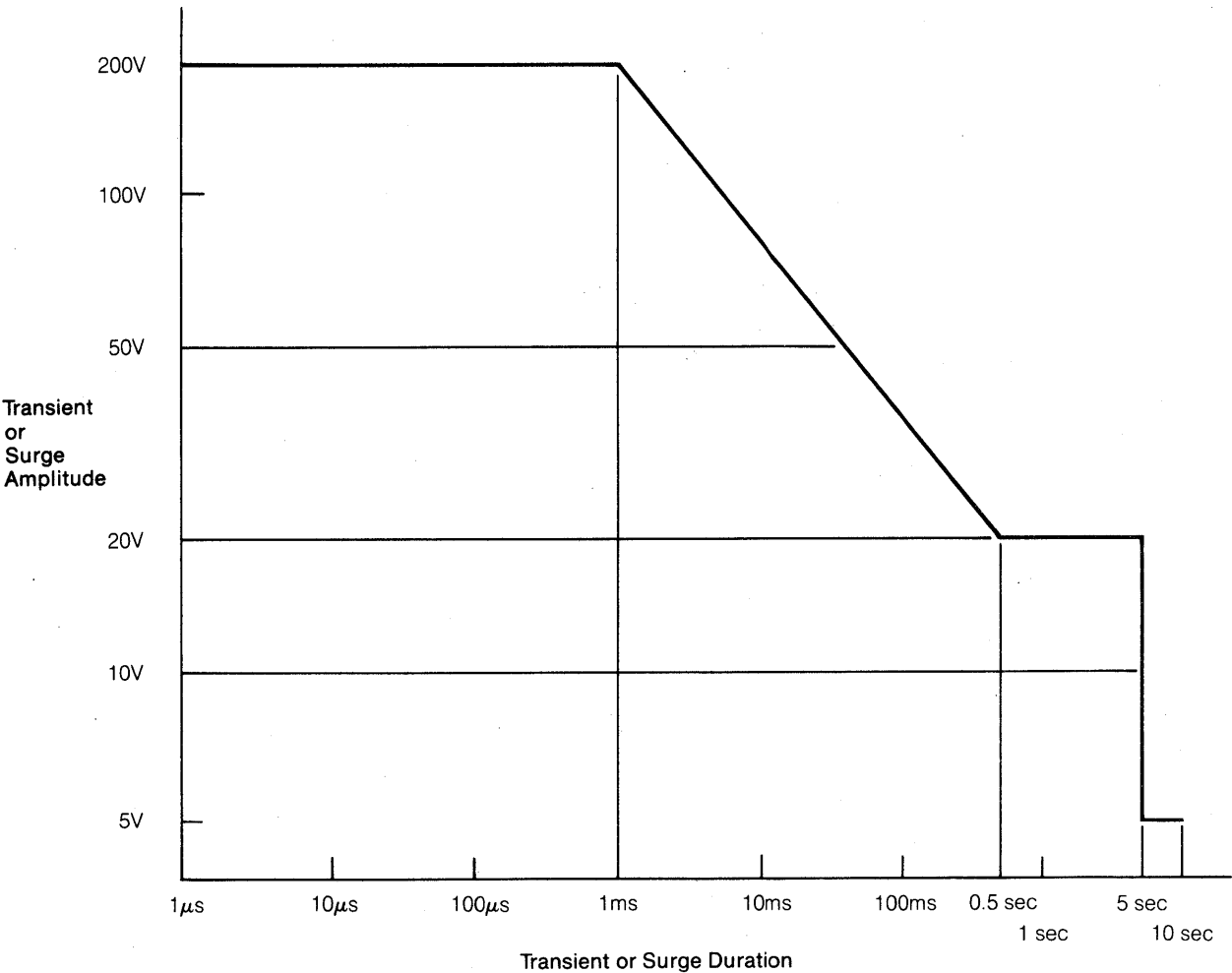

Figure B-1. Allowable Transient and Surge Voltage Amplitudes

Direct Connections

The Asynchronous Serial Interface (ASI) (HP Product 45120B), is capable of communicating with supported workstations, printers, and plotters via a RS-232-C data link, using a direct hardwired connection. The EIA RS-232-C standard defines the mechanical/electrical characteristics for devices which can connect to the ASI interface. Hewlett-Packard supports operation of the RS-232-C data link only with the specific devices shown in Figure B-2. Any changes in supported options are reported in the Configuration Guide which is available from your sales representative.

Electrical Specifications

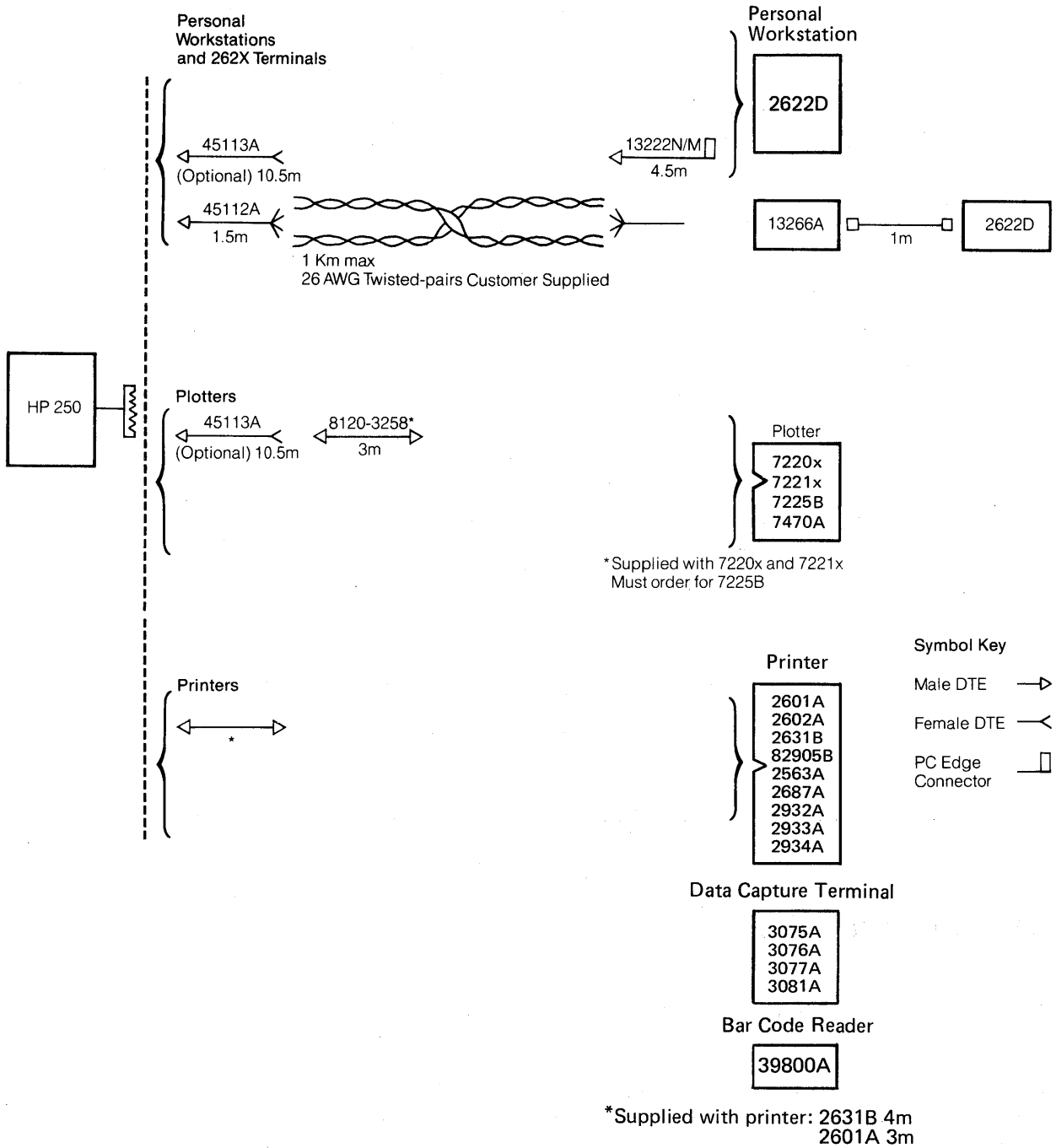
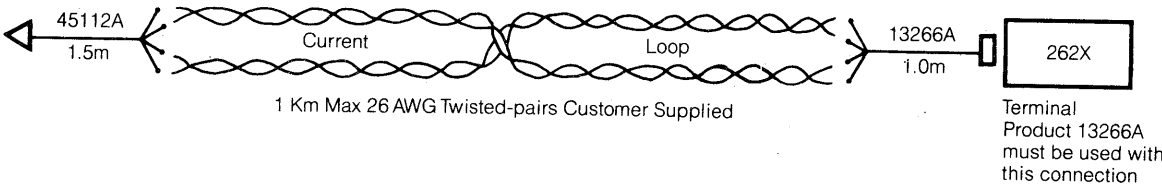

Figure B-2. ASI Cable Connections

If you want to locate the additional HP 2622D workstation or the HP 2631B printer farther than 15m (50 ft) from the computer, a current loop connection can be used for distances up to 1km (0.6 mile). Refer to Figure B-3 for details on making the cable and all required connections.

262X Terminal Connected to ASI with Current Loop Connection



Cable Wiring for Current Loop Connection

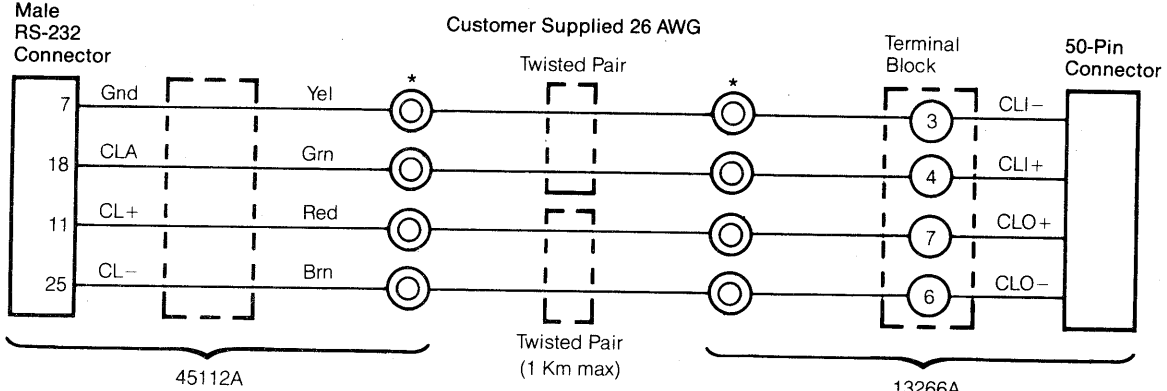

- CLA — Current Loop Transmit
- Gnd — Signal Ground
- CL+ — Current Loop Receive (in)
- CL- — Current Loop Receive (out)

- CLI- — Current Loop Receive (out)
- CLI+ — Current Loop Receive (in)
- CLO+ — Current Loop Transmit (out)
- CLO- — Current Loop Transmit (in)

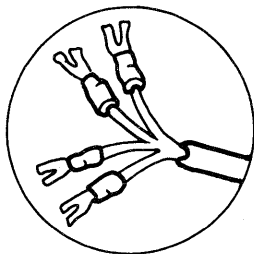

*Detail of cable end:

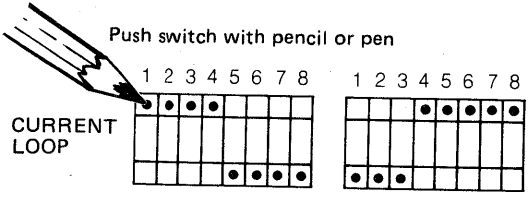

ASI Port (1, 2, or 5) Switch Settings for Current Loop Connection

10-Position Rocker Switch Setting. Inside 13266A POD:

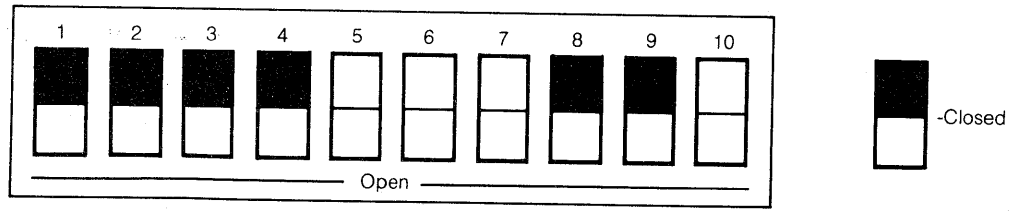

Note: Self-test switch should be in normal position.

Figure B-3

Electrical Specifications

See Figure B-4 for details on fabricating your own three-wire data communications cable. This particular cable configuration is not supported by HP.

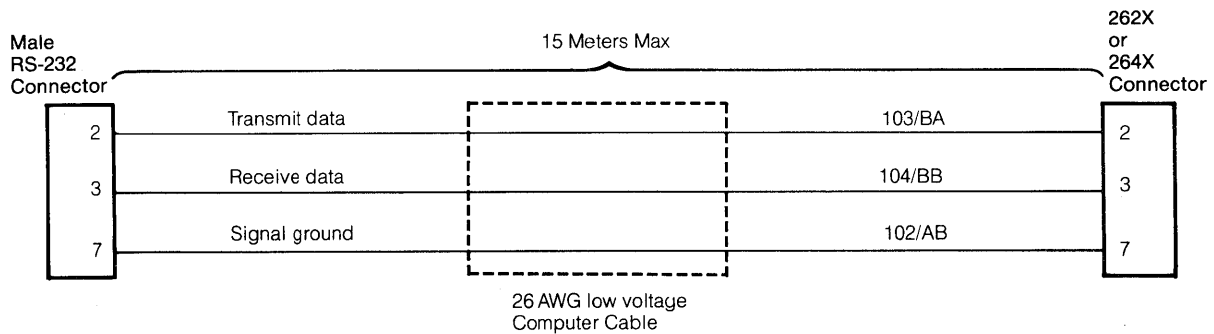

Item	HP Part No.	Description	Alternate Source
RS-232 Connector Kit	5061-2405	Includes male and female RS-232 Connectors (1 each)	
262X Connector Kit	5061-2412	Includes one 50-pin Connector	Amphenol 57-30500
Connector Cable	8120-1950	12 conductor, shielded	U.L. style 2560
	8120-2398	16 conductor, shielded	U.L. style 2560

Figure B-4. Fabricating Your Own Three-Wire Cable

Approvals

HP 250 Models 20 and 25 have the following regulatory approvals:

Safety:

- o UL 114, Office Machines
- o UL 478, Data Processing Equipment
- o CSA C22.2 No. 154, Data Processing Equipment

RFI:

- o HP 250 Model 20 and 25, FTZ License No. C-032/81

Data Communications:

- o Germany, United Kingdom, Australia, France, Belgium, Finland, Switzerland, Sweden

Note: U.S.A. does not require regulatory approval.

APPENDIX C

Customer Engineer Locations

CANADA

Calgary

Hewlett-Packard Canada Ltd.
210, 7220 Fisher St. S.W.
Calgary, Alberta T2H 2H8
Phone: 403/253-2713
CEO: P

Edmonton

Hewlett-Packard Canada Ltd.
11620A 168th Street
Edmonton, Alberta T5M 3T9
Phone: 403/452-3670
CEO: P SEO: S

Halifax

Hewlett-Packard Canada Ltd.
900 Windmill Road
Dartmouth, Nova Scotia B2Y 3Z6
Phone: 902/469-7820
CEO: P SEO: S

London

Hewlett-Packard Canada Ltd.
552 Newbold Street
London, Ontario N6E 2S5
Phone: 519/686-9181
CEO: S

Moncton

Hewlett-Packard Canada Ltd.
190 Wilbur Street
Moncton, New Brunswick
E1B 1V0
Phone: 506/386-1677
CEO: S

Montreal

Hewlett-Packard Canada Ltd.
17500 South Service Road
Trans-Canada Highway
Kirkland, Quebec H9J 2M5
Phone: 514/697-4232
CEO: P SEO: P

Ottawa

Hewlett-Packard Canada Ltd.
1020 Morrison Drive
Ottawa, Canada K2H 8K7
Phone: 613/820-6483
CEO: P SEO: S

Quebec City

Hewlett-Packard Canada Ltd.
2323 Boulevard du Versant Nord
Saint Foy, Quebec J1N 4C2
Phone: 413/687-4570
CEO: S

Toronto

Hewlett-Packard Canada Ltd.
6877 Goreway Drive
Mississauga, Ontario L4V 1M8
Phone: 416/678-9430
CEO: P SEO: P

Vancouver

Hewlett-Packard Canada Ltd.
10691 Shellbridge Way
Richmond, British Columbia
V6X 2W7
Phone: 604/270-2277
CEO: P SEO: S

Winnipeg

Hewlett-Packard Canada Ltd.
380-550 Century Street
Saint James
Winnipeg, Manitoba
R34 0L8
Phone: 204/786-6701
CEO: S

UNITED STATES

Alabama

Birmingham

Hewlett-Packard Company
Suite 128
700 Century Park South
Birmingham, Alabama 35226
Phone: 205/822-6802
CEO: S

Huntsville

Hewlett-Packard Company
P.O. Box 4207
8290 Whitesburg Drive, S.E.
Huntsville, Alabama 35802
Phone: 205/881-4591
CEO: P SEO: S

Alaska

Anchorage

Hewlett-Packard Company
Suite 252
1577 'C' Street
Anchorage, Alaska 99510
Phone: 206/454-3971
CEO: SLZ

Arizona

Phoenix

Hewlett-Packard Company
2336 E. Magnolia Street
Phoenix, Arizona 85034
Phone: 602/273-8000
CEO: P SEO: S

Tucson

Hewlett-Packard Company
2424 E. Aragon Road
Tucson, Arizona 85706
Phone: 602/899-4661
CEO: S

California

Los Angeles East

Hewlett-Packard Company
1430 E. Orangethorpe
Fullerton, California 92631
Phone: 714/870-1000
CEO: P SEO: P

Los Angeles North

Hewlett-Packard Company
7261 Canoga Avenue
Canoga Park, California 91304
Phone: 213/702-8300
CEO: P SEO: P

Los Angeles West

Hewlett-Packard Company
5400 W. Rosecrans Blvd.
Lawndale, California 90260
Phone: 213/970-7500
CEO: P SEO: P

Palo Alto

Hewlett-Packard Company
3200 Hillview Avenue
Palo Alto, California 94304
Phone: 415/857-8000
CEO: P SEO: P

Sacramento

Hewlett-Packard Company
646 W. North Market Blvd.
Sacramento, California 95834
Phone: 916/929-7222
CEO: P SEO: S

San Diego

Hewlett-Packard Company
9606 Aero Drive
San Diego, California 92123
Phone: 714/279-3200
CEO: P SEO: S

CEO(Customer Engineering Organization)—hardware maintenance service available.

SEO(Systems Engineering Organization)—software support available

P(Primary)—Primary SRO

S(Secondary)—Secondary SRO

L(Limited)—The entire product line of HP computers is not presently supported by this SRO. Contact your nearest SRO for office capabilities.

s(Standard)—The SRO provides routine support during the Standard Coverage Hours.

b(Basic)—The SRO provides routine support during the Basic Coverage Hours.

Z(Zones)—The response times and fixed travel charges may vary due to local travel conditions.

Customer Engineer Locations

San Francisco

Hewlett-Packard Company
454 Carlton Court
So. San Francisco
California 94080
Phone: 415/877-0772
CEO: P SEO: P

Santa Barbara

Hewlett-Packard Company
Suite A
5553 Hollister
Santa Barbara, California 93111
Phone: 805/964-3390
CEO: S

Santa Clara

Hewlett-Packard Company
3003 Scott Boulevard
Santa Clara, California 95050
Phone: 408/988-7000
CEO: P SEO: P

Colorado

Denver

Hewlett-Packard Company
24 Inverness Place
Englewood, Colorado 80112
Phone: 303/771-3455
CEO: P SEO: P

Connecticut

New Haven

Hewlett-Packard Company
47 Barnes Industrial Road South
Wallingford, Connecticut 06492
Phone: 203/265-7801
CEO: P SEO: S

Florida

Fort Lauderdale

Hewlett-Packard Company
2727 N.W. 62nd Street
Fort Lauderdale, Florida 33309
Phone: 305/973-2600
CEO: P SEO: S

Orlando

Hewlett-Packard Company
6177 Lake Ellenor Drive
Orlando, Florida 32809
Phone: 305/859-2900
CEO: P SEO: P

Tampa

Hewlett-Packard Company
Suite 120
110 S. Hoover Boulevard
Tampa, Florida 33609
Phone: 813/872-0900
CEO: S SEO: S

Georgia

Atlanta

Hewlett-Packard Company
2000 South Park Place
Atlanta, Georgia 30339
Phone: 404/955-1500
CEO: P SEO: P

Hawaii

Honolulu

Hewlett-Packard Company
567 South King Street
Honolulu, Hawaii 96813
Phone: 808/526-1555
CEO: S

Idaho

Boise

Hewlett-Packard Company
11311 Chinden Boulevard
Boise, Idaho 83707
Phone: 208/376-6000
CEO: S

Illinois

Bloomington

Hewlett-Packard Company
211 Prospect Road
Bloomington, Illinois 61701
Phone: 309/663-0383
CEO: S

Chicago South

Hewlett-Packard Company
1100 31st Street
Downer's Grove, Illinois 60515
Phone: 312/960-5760
CEO: P SEO: P

Chicago West

Hewlett-Packard Company
5201 Tollview Drive
Rolling Meadows, Illinois 60008
Phone: 312/255-9800
CEO: P SEO: P

Indiana

Indianapolis

Hewlett-Packard Company
7301 N. Shadeland Avenue
Indianapolis, Indiana 46250
Phone: 317/842-1000
CEO: P SEO: S

Iowa

Cedar Rapids

Hewlett-Packard Company
2415 Heinz Road
Iowa City, Iowa 52240
Phone: 319/351-1020
CEO: S

Des Moines

Hewlett-Packard Company
5815 S.W. 5th Street
Des Moines, Iowa 50315
Phone: 515/243-5876
CEO: S

Kansas

Wichita

Hewlett-Packard Company
1644 South Rock
Wichita, Kansas 67207
Phone: 316/265-5200
CEO: S

Kentucky

Louisville

Hewlett-Packard Company
Suite 525
10170 Linn Station Road
Louisville, Kentucky 40223
Phone: 502/426-0100
CEO: S SEO: S

Louisiana

New Orleans

Hewlett-Packard Company
3229 Williams Boulevard
Kenner, Louisiana 70062
Phone: 504/443-6201
CEO: P SEO: S

Maryland

Baltimore

Hewlett-Packard Company
7121 Standard Drive
Hanover, Maryland 21076
Phone: 301/796-7700
CEO: P SEO: P

Washington D.C.

Hewlett-Packard Company
2 Choke Cherry Road
Rockville, Maryland 20850
Phone: 301/948-6370
CEO: P SEO: P

Massachusetts

Boston

Hewlett-Packard Company
32 Hartwell Avenue
Lexington, Massachusetts 02173
Phone: 617/861-8960
CEO: P SEO: P

Michigan

Detroit

Hewlett-Packard Company
23855 Research Drive
Farmington Hills, Michigan
48024
Phone: 313/476-6400
CEO: P SEO: P

Grand Rapids

Hewlett-Packard Company
4326 Cascade Road S.E.
Grand Rapids, Michigan 49506
Phone: 616/957-1970
CEO: P SEO: S

Minnesota

Minneapolis/St. Paul

Hewlett-Packard Company
2025 W. Larpenteur Avenue
St. Paul, Minnesota 55113
Phone: 612/644-1100
CEO: P SEO: P

Missouri

Kansas City

Hewlett-Packard Company
11131 Colorado
Kansas City, Missouri 64137
Phone: 816/763-8000
CEO: P SEO: S

Saint Louis

Hewlett-Packard Company
1024 Executive Parkway
Saint Louis, Missouri 63141
Phone: 314/878-0200
CEO: P SEO: P

New Jersey

Paramus

Hewlett-Packard Company
W120 Century Road
Paramus, New Jersey 07652
Phone: 201/265-5000
CEO: P SEO: P

Piscataway

Hewlett-Packard Company
60 New England Avenue West
Piscataway, New Jersey 08854
Phone: 201/981-1199
CEO: P SEO: P

New Mexico

Albuquerque

Hewlett-Packard Company
11300 Lomas Blvd.—N.E.
Albuquerque, New Mexico 87192
Phone: 505/292-1330
CEO: P SEO: P

New York

Albany

Hewlett-Packard Company
5 Computer Drive South
Albany, New York 12205
Phone: 518/458-1550
CEO: S

Buffalo

Hewlett-Packard Company
9600 Main Street
Clarence, New York 14031
Phone: 716/759-8621
CEO: S

Long Island

Hewlett-Packard Company
3 Crossways Park West
Woodbury, New York 11797
Phone: 516/921-0300
CEO: P SEO: S

Manhattan

Hewlett-Packard Company
1 Pennsylvania Plaza
55th Floor, 34th Street & 8th
Avenue
New York City, New York 10001
Phone: 212/971-0800
CEO: P SEO: P

Rochester

Hewlett-Packard Company
200 Cross Keys Office
Fairport, New York 14450
Phone: 716/223-9950
CEO: P SEO: P

Syracuse

Hewlett-Packard Company
5858 East Molloy Road
Syracuse, New York 13211
Phone: 315/455-2486
CEO: S

North Carolina

Greensboro

Hewlett-Packard Company
5605 Roanne Way
Greensboro, North Carolina
27409
Phone: 919/852-1800
CEO: P SEO: S

Ohio

Cincinnati

Hewlett-Packard Company
9920 Carver Road
Cincinnati, Ohio 45242
Phone: 513/891-9870
CEO: P SEO: S

Cleveland

Hewlett-Packard Company
16500 Sprague Road
Cleveland, Ohio 44130
Phone: 216/243-7300
CEO: P SEO: P

Columbus

Hewlett-Packard Company
962 Crupper Avenue
Columbus, Ohio 43229
Phone: 614/432-1041
CEO: P SEO: S

Dayton

Hewlett-Packard Company
330 Progress Road
Dayton, Ohio 45449
Phone: 513/859-8202
CEO: P

Oklahoma

Oklahoma City

Hewlett-Packard Company
304 N. Meridan Avenue, Suite A
P.O. Box 32008
Oklahoma City, Oklahoma 73107
Phone: 405/946-9499
CEO: P

Tulsa

Hewlett-Packard Company
Suite 121
9920 E. 42nd Street
Tulsa, Oklahoma 74145
Phone: 918/665-3300
CEO: S SEO: S

Oregon

Portland

Hewlett-Packard Company
9255 Pioneer Court
Wilsonville, Oregon 97070
Phone: 503/682-8000
CEO: P SEO: S

Pennsylvania

Philadelphia

Hewlett-Packard Company
1021 8th Avenue
King of Prussia Industrial Park
King of Prussia, Pennsylvania
19406
Phone: 215/265-7000
CEO: P SEO: P

Pittsburgh

Hewlett-Packard Company

111 Zeta Drive
Pittsburgh, Pennsylvania 15238
Phone: 412/782-0400
CEO: P SEO: P

South Carolina

Columbia

Hewlett-Packard Company
6941-0 No. Trenholm Rd.
P.O. Box 6442
Columbia, South Carolina 29260
Phone: 803/782-6493
CEO: S

Tennessee

Knoxville

Hewlett-Packard Company
224 Peters Road
Suite 102
Knoxville, Tennessee 37922
Phone: 615/691-2371
CEO: S

Memphis

Hewlett-Packard Company

3070 Directors Row
Directors Square
Memphis, Tennessee 38131
Phone: 901/346-8370
CEO: S

Texas

Dallas

Hewlett-Packard Company

930 East Campbell Road
Richardson, Texas 75081
Phone: 214/231-6101
CEO: P SEO: P

El Paso

Hewlett-Packard Company

Suite C-110
4171 North Mesa
El Paso, Texas 79902
Phone: 915/533-3555
CEO: S

CEO(Customer Engineering Organization)—hardware maintenance service available.

SEO(Systems Engineering Organization)—software support available

P(Primary)—Primary SRO

S(Secondary)—Secondary SRO

L(Limited)—The entire product line of HP computers is not presently supported by this SRO. Contact your nearest SRO for office capabilities.

s(Standard)—The SRO provides routine support during the Standard Coverage Hours.

b(Basic)—The SRO provides routine support during the Basic Coverage Hours.

Z(Zones)—The response times and fixed travel charges may vary due to local travel conditions.

Customer Engineer Locations

Houston

Hewlett-Packard Company
10535 Harwin Street
Houston, Texas 77036
Phone: 713/776-6400
CEO: P SEO: P

San Antonio

Hewlett-Packard Company
205 Billy Mitchell Road
San Antonio, Texas 78226
Phone: 512/434-8241
CEO: S SEO: S

Utah

Salt Lake City

Hewlett-Packard Company
3550 W. 2100 South Street
Salt Lake City, Utah 84119
Phone: 801/974-1700
CEO: P SEO: S

Virginia

Norfolk

Hewlett-Packard Company
5700 Thurston Avenue
Virginia Beach, Virginia 23455
Phone: 804/460-2471
CEO: S

Richmond

Hewlett-Packard Company
2914 Hungary Spring Road
Richmond, Virginia 23228
Phone: 804/285-3431
CEO: P SEO: P

Roanoke

Hewlett-Packard Company
3110 Peters Creek Road, N.W.
Roanoke, Virginia 24015
Phone: 703/922-7000
CEO: S

Washington

Seattle

Hewlett-Packard Company
15815 S.E. 37th Street
Bellevue, Washington 98006
Phone: 206/643-4000
CEO: P SEO: P

Spokane

Hewlett-Packard Company
Suite A-1
708 North Argonne Road
Spokane, Washington 99206
Phone: 509/535-0864
CEO: S SEO: S

Wisconsin

Milwaukee

Hewlett-Packard Company
150 S. Sunnyslope Road
Brookfield, Wisconsin 53005
Phone: 414/784-8800
CEO: S SEO: S

EUROPE and MIDDLE EAST

Austria

Graz

Hewlett-Packard Ges.m.b.h.
Veraufsbuero Graz
Grottenhofstrasse 94
Graz A-8052
Austria
Phone: 316/21566
CEO: Sb

Vienna

Hewlett-Packard Ges.m.b.h.
Wehlistrasse 29
Vienna A-1205
Austria
Phone: 222/351-6210
CEO: P SEO: P

Belgium

Brussels

Hewlett-Packard Belgium S.A.
Woluwedal 101
Boulevard de la Woluwe 100
Brussels B-1200
Belgium
Phone: 2/762-3200
CEO: P SEO: P

Denmark

Copenhagen

Hewlett-Packard A/S
Datavej 52
Birkerod DK-3460
Denmark
Phone: 2/81-66-40
CEO: P SEO: P

Silkeborg

Hewlett-Packard A/S
Navervej 1
Silkeborg DK-8600
Denmark
Phone: 6/82-71-66
CEO: S

Finland

Helsinki

Hewlett-Packard Oy
Revontulentie 7
Espoo SF-02100
Finland
Phone: 90/455-0211
CEO: Ps SEO: P

France

Aix-en-Provence

Hewlett-Packard France
Place Romee de Villeneuve le
Ligoures
Aix-en-Provence F-13090
France
Phone: 42/59-41-02
CEO: P

Besancon

Hewlett-Packard France
28 Rue de la Republique
Besancon F-25000
France
Phone: 81/83-16-22
CEO: S

Bordeaux

Hewlett-Packard France
Avenue du President JFK
Merignac F-33700
France
Phone: 56/34-00-84
CEO: P

Grenoble

Hewlett-Packard France
5 Avenue Raymond Chanas
Eybens F-38320
France
Phone: 76/25-81-41
CEO: S

Lille

Hewlett-Packard France
Rue Van Gogh
Immeuble Pericentre
Villeneuve D'Ascq F-59650
France
Phone: 20/91-41-25
CEO: S

Lyon

Hewlett-Packard France
Chemin des Mouilles
Boites Postale No. 162
Ecully F-69130
France
Phone: 78/33-81-25
CEO: P SEO: P

Metz

Hewlett-Packard France
32 Rue Lothaire
Metz F-57500
France
Phone: 87/65-53-50
CEO: S

Nantes

Hewlett-Packard France
Bureau 210
2 Bis Rue Julien Videment
Nantes F-44200
France
Phone: 40/48-09-44
CEO: S

Paris Downtown

Hewlett-Packard France
15 Bd de L'Admiral Bruix
Paris F-75016
France
Phone: 1/502-1220
CEO: P

Paris North

Hewlett-Packard France
Batiment Ampere, BP 300
Rue de la Commune de Paris
Le Blanc Mesnil F-93153
France
Phone: 1/865-4452
CEO: P SEO: P

Paris South

Hewlett-Packard France
Zone Industrielle de BP6
Courtaboeuf Av. Des Tropiques
Orsay F-91401
France
Phone: 1/907-7825
CEO: P SEO: P

Rennes

Hewlett-Packard France
2 Allee de la Bourgonette
Rennes F-35100
France
Phone: 99/51-42-44
CEO: S

Rouen

Hewlett-Packard France
98 Avenue de Bretagne
Rouen F-76100
France
Phone: 35/63-57-66
CEO: S

Strasbourg

Hewlett-Packard France
4 Rue Thomas Mann
Strasbourg HautePierre
Schiltigheim F-67033
France
Phone: 88/28-56-46
CEO: S

Toulouse

Hewlett-Packard France
20 Chemin de la Cepiere
Toulouse F-31081
France
Phone: 61/40-11-12
CEO: S

Germany**Duesseldorf**

Hewlett-Packard GmbH
Emanuel-Leutze-Strasse 1
Duesseldorf D-4000
Germany
Phone: 211/5971-1
CEO: P SEO: S

Frankfurt

Hewlett-Packard GmbH
Vertriebszentrale Frankfurt
Bernner Strasse 117
Frankfurt D-6000-56
Germany
Phone: 611/50-04-1
CEO: P SEO: P

Hamburg

Hewlett-Packard GmbH
Kapstading 5
Hamburg D-2000-60
Germany
Phone: 40/63804-1
CEO: P SEO: S

Hannover

Hewlett-Packard GmbH
Am Grossmarkt 6
Hannover D-3000-91
Germany
Phone: 511/46-60-01
CEO: S

Munich

Hewlett-Packard GmbH
Eschenstrasse 5
Taufkirchen D-8021
Germany
Phone: 89/6117-1
CEO: P SEO: S

Nuremberg

Hewlett-Packard GmbH
Neumeyerstrasse 90
Nuremberg D-8500
Germany
Phone: 911/56-30-83
CEO: S

Stuttgart

Hewlett-Packard GmbH
Herrenberger Strasse 110
Boeblingen D-7030
Germany
Phone: 7031/667-1
CEO: P SEO: P

West Berlin

Hewlett-Packard GmbH
Keithstrasse 2-4
West Berlin D-1000-30
Germany
Phone: 30/24-90-86
CEO: S

Great Britain**Birmingham South**

Hewlett-Packard Ltd.
Westminster House
190 Stratford Road
Solihull B90 3BJ
Great Britain
Phone: 21/745-8800
CEO: P

Bristol

Hewlett-Packard Ltd.
Oakfield House, Oakfield Grove
Clifton, Bristol BS8 2BN
Great Britain
Phone: 272/386-06
CEO: S

Castleford

Hewlett-Packard Ltd.
14 Wesley Street
Castleford WF10 1AE
Great Britain
Phone: 977/550-016
CEO: P

London Downtown

Hewlett-Packard Ltd.
9 Savoy Street
London WC2R 0BA
Great Britain
CEO: P

London North

Hewlett-Packard Ltd.
Fourier House
257-263 High Street
London Colney AL2 1HA
Great Britain
Phone: 727/24-400
CEO: P SEO: S

London South

Hewlett-Packard Ltd.
106-118 Station Road
Redhill RH1 IPS
Great Britain
Phone: 737/68-655
CEO: P SEO: S

London West

Hewlett-Packard Ltd.
Tradax House
St. Mary's Walk
Maidenhead SL6 1ST
Great Britain
Phone: 628/39-151
CEO: P SEO: S

Manchester

Hewlett-Packard Ltd.
Trafalgar House
Navigation Road
Altrincham WA14 1NU
Great Britain
Phone: 61/928-6422
CEO: P SEO: P

CEO(Customer Engineering Organization)—hardware maintenance service available.

SEO(Systems Engineering Organization)—software support available

P(Primary)—Primary SRO

S(Secondary)—Secondary SRO

L(Limited)—The entire product line of HP computers is not presently supported by this SRO. Contact your nearest SRO for office capabilities.

s(Standard)—The SRO provides routine support during the Standard Coverage Hours.

b(Basic)—The SRO provides routine support during the Basic Coverage Hours.

Z(Zones)—The response times and fixed travel charges may vary due to local travel conditions.

Customer Engineer Locations

Winnersh

Hewlett-Packard Ltd.
King Street Lane
Winnersh RG11 5AR
Great Britain
Phone: 734/784-774
SEO: P

Ireland

Dublin

Hewlett-Packard Ltd.
Kestrel House, Clanwilliam Pl
Lower Mount Street
Dublin 2
Ireland
Phone: 1/680424
CEO: PsZ SEO: SLZ

Italy

Bologna

Hewlett-Packard Italiana S.p.A
Via Martin Luther King, 38/III
Bologna I-40132
Italy
Phone: 51/402394
CEO: S

Milan

Hewlett-Packard Italiana S.p.A
Via G. Di Vittorio 9
Cernusco Sul Naviglio
I-20063
Italy
Phone: 2/903691
CEO: P SEO: P

Naples

Hewlett-Packard Italiana S.p.A
Via Nuova San Rocco A
Capadimonte, 62A
Naples I-80135
Italy
Phone: 81/741-3544
CEO: S

Padova

Hewlett-Packard Italiana S.p.A
Via Turazza 14
Padova I-35100
Italy
Phone: 49/664888
CEO: S

Rome

Hewlett-Packard Italiana S.p.A
Viale C. Pavese 340
Rome I-00144
Italy
Phone: 6/54831
CEO: S SEO: S

Torino

Hewlett-Packard Italiana S.p.A
Corso Giovanni Lanza 94
Torino I-10133
Italy
Phone: 11/682245
CEO: S

Netherlands

Amsterdam

Hewlett-Packard Nederland B.V.
Van Heuven Goedhartlaan 121
Amstelveen NL-1181KK
Netherlands
Phone: 20/47-20-21
CEO: P SEO: P

Rotterdam

Hewlett-Packard Nederland B.V.
Bongerd 2
Capelle NL-2906VK
Netherlands
Phone: 10/51-64-44
CEO: P SEO: P

Norway

Bergen

Hewlett-Packard Norge A/S
Oasen Folke Bernadottes Vei 50
P.O. Box 3558
Fyllingsdalen N-5033
Norway
Phone: 5/16-55-40
CEO: SLbZ

Oslo

Hewlett-Packard Norge A/S
Oesterudalen 18
Oesteraas N-1345
Norway
Phone: 2/17-11-80
CEO: PLsZ SEO: PZ

Scotland

Brechin

Hewlett-Packard Ltd.
Royal Bank Buildings
Swan Street
Brechin, Angus EH39 TG
Scotland
Phone: 3562/3101
CEO: S

Edinburgh

Hewlett-Packard Ltd.
South Queensferry
West Lothian EH30 9TG
Scotland
Phone: 31/331-1000
CEO: PZ SEO: SZ

Spain

Barcelona

Hewlett-Packard Espanola S.A.
Entenza 321
Barcelona E-29
Spain
Phone: 3/322-2451
CEO: P SEO: SL

Bilbao

Hewlett-Packard Espanola S.A.
San Vicente s/n
Edificio Albia II, 7B
Bilbao E-1
Spain
Phone: 44/423-8206
CEO: Sb

Madrid

Hewlett-Packard Espanola S.A.
Costa Brava, 13-2
Madrid E-34
Spain
Phone: 1/734-8061
CEO: P SEO: P

Seville

Hewlett-Packard Espanola S.A.
Avenida Ramon y Cajal 1
Edificio Sevilla 1, Planta 9
Seville E-5
Spain
Phone: 954/64-44-54
CEO: Sb

Valencia

Hewlett-Packard Espanola S.A.
Ramon Cordillo, Entresuelo-3
Valencia E-10
Spain
Phone: 96/361-1354
CEO: Sb

Sweden

Goetenborg

Hewlett-Packard Sverige AB
Frotallsgatan 30
Vastra Frolunda S-42132
Sweden
Phone: 31/49-09-50
CEO: S

Lund

Hewlett-Packard Sverige AB
Sunnanvagen 14K
Lund S-22226
Sweden
Phone: 46/13-69-79
CEO: Sb

Orebro

Hewlett-Packard Sverige AB
Ostra Vintergatan 22
Orebro S-70344
Sweden
Phone: 19/14-07-20
CEO: Sb

Stockholm

Hewlett-Packard Sverige AB
Enighetsvagen 3
Bromma S-16120
Sweden
Phone: 8/730-0550
CEO: P SEO: P

Switzerland

Bern

Hewlett-Packard (Schweiz) AG
Bahnhofstrasse 44
Bern CH-3018
Switzerland
Phone: 31/56-24-22
CEO: S

Geneva

Hewlett-Packard (Schweiz) AG
47 Avenue Blanc
Geneva CH-1202
Switzerland
Phone: 22/32-30-05
CEO: P SEO: S

Zurich

Hewlett-Packard (Schweiz) AG
Zurcherstrasse 20
Allmend 2
Widen CH-8967
Switzerland
Phone: 57/50-111
CEO: P SEO: P

Argentina**Buenos Aires**

Hewlett-Packard Argentina S.A.
Avda Santa Fe 2035
Martinez 1640
Argentina
Phone: 798-6086
CEO: PLbZ SEO: PLZ

Mexico**Mexico City**

Hewlett-Packard Mexicana SACV
Av. Periferico Sur No. 6501
Tepepan, Xochimilco
Mexico City 23,DF
Mexico
Phone: 905/676-4600
CEO: PLZ SEO: PLZ

Monterrey

Hewlett-Packard Mexicana SACV
Rio Volga #600
Colonia del Valle
Monterrey NL
Mexico
Phone: 83/78-42-93
CEO: SLb

Puerto Rico**San Juan**

Hewlett-Packard Puerto Rico
Calle 272
203 Urb. Country Club
Carolina 00630
Puerto Rico
Phone: 809/762-7255
CEO: PLsZ SEO: PLZ

Venezuela**Caracas**

Hewlett-Packard Venezuela C.A.
Edificio Segre 2Y3
3a Transversal Los Ruices Nort
Caracas 1071
Venezuela
Phone: 2/239-4133
CEO: PLsZ SEO: PLZ

Australia**Adelaide**

Hewlett-Packard Australia Pty.
153 Greenhill Road
Parkside, South Australia 5063
Australia
Phone: 8/272-5911
CEO: SL

Brisbane

Hewlett-Packard Australia Pty.
Teachers Union Bldg., Floor 5
495-499 Boundary Street
Spring Hill, Queensland 4000
Australia
Phone: 72/229-1544
CEO: SL

Canberra

Hewlett-Packard Australia Pty.
121 Wollongong Street
Fyshwick
Australia Capital Territory
2609
Australia
Phone: 62/804-244
CEO: SL

Perth

Hewlett-Packard Australia Pty.
141 Stirling Highway
Nedlands
Western Australia 6009
Australia
Phone: 92/386-5455
CEO: SL

Melbourne

Hewlett-Packard Australia Pty.
31-41 Joseph Street
Blackburn, Victoria 3130
Australia
Phone: 3/89-6351
CEO: P SEO: PLZ

Sydney

Hewlett-Packard Australia Pty.
17-23 Talavera Road
North Ryde
New South Wales 2113
Australia
Phone: 2/887-1611
CEO: P SEO: PLZ

Hong Kong**Hong Kong**

Hewlett-Packard Hong Kong Ltd.
5 Floor Sun Hung Kai Centre
30 Harbour Road, Wanchai
Hong Kong
CEO: PLZ SEO: PLZ

Japan**Kumagaya**

Yokogawa-Hewlett-Packard Ltd.
Kumagaya Ashai Building
4 Tusukuba, 3-chome
Kumagaya, Saitama 360
Japan
Phone: 485/24-6563
CEO: SLbZ

Mito

Yokogawa-Hewlett-Packard Ltd.
Mito Mitsui Building
4-73, San-no-maru, 1-chome
Mito, Ibaragi 310
Japan
Phone: 292/25-7470
CEO: SLbZ

Nagoya

Yokogawa-Hewlett-Packard Ltd.
Sunitomo Seimei Building
11-2 Shimo-sasajima-cho
Nagoya, Aichi 450
Japan
Phone: 52/581-1850
CEO: SLbZ SEO: PLZ

Osaka

Yokogawa-Hewlett-Packard Ltd.
Chuo Bldg., 4th Floor
54-20 Nishinakajima, 5-chome
Osaka, Osaka-Shi 532
Japan
Phone: 6/304-6021
CEO: PLZ SEO: PLZ

Tokyo

Yokogawa-Hewlett-Packard Ltd.
29-21 Takaido-Higashi 3-chome
Tokyo, Suginami-ku 168
Japan
Phone: 3/331-6111
CEO: PLZ SEO: PLZ

Yokohama

Yokogawa-Hewlett-Packard Ltd.
3-30-18 Tsuruya-cho
Kanagawa-Ku, Yokohama-Shi
Kanagawa 221
Japan
Phone: 45/312-1252
CEO: SLbZ

Malaysia**Kuala Lumpur**

Hewlett-Packard Malaysia S.B.
2.21 Bangunan Angkasa Raya
Jalan Ampang
Kuala Lumpur
Malaysia
Phone: 483544
CEO: PLbZ

New Zealand**Auckland**

Hewlett-Packard New Zealand
169 Manukau Road
Pakuranga
New Zealand
Phone: 9/68-7159
CEO: SL

CEO(Customer Engineering Organization)—hardware maintenance service available.

SEO(Systems Engineering Organization)—software support available

P(Primary)—Primary SRO

S(Secondary)—Secondary SRO

L(Limited)—The entire product line of HP computers is not presently supported by this SRO. Contact your nearest SRO for office capabilities.

S(Standard)—The SRO provides routine support during the Standard Coverage Hours.

b(Basic)—The SRO provides routine support during the Basic Coverage Hours.

Z(Zones)—The response times and fixed travel charges may vary due to local travel conditions.

Customer Engineer Locations

Wellington

Hewlett-Packard New Zealand
4-12 Cruickshank Street
Wellington 3
New Zealand
Phone: 4/877-199
CEO: PLsZ

Singapore

Hewlett-Packard Singapore Ltd.
6th Floor, Inchcape House
450-452 Alexandra Road
Singapore 0511
Phone: 631788
CEO: PLs SEO: PLZ

South Africa

Cape Town
Hewlett-Packard South Africa
Pine Park Centre
Forest Avenue Pinelands
Cape Town
Cape Province 7405
South Africa
Phone: 21/53-7955
CEO: SLZ

Durban

Hewlett-Packard South Africa
2nd Floor Juniper House
92 Overport Drive
Durban, Natal 4067
South Africa
Phone: 31/802-5111
CEO: SLZ

Johannesburg

Hewlett-Packard South Africa
Hewlett-Packard Building
Daphne Street Wendywood
Sandton, Transvaal 2144
South Africa
Phone: 11/802-5111
CEO: PLZ SEO: PLZ

Pretoria

Hewlett-Packard South Africa
Pretoria
Transvaal
CEO: SLZ

Taiwan

Taipei
Hewlett-Packard Far East Ltd.
Bank Tower, 5th Floor
205 Tun Hwa North Road
Taipei
Phone: 2/751-0404
CEO: PLsZ SEO: PLZ

INTERCONTINENTAL

Chile

Santiago

Olympia (Chile) Ltda.
Rodrigo de Araya 1045
Casilla 256-V, Santiago 21
Chile
Phone: 25-50-44

Guatemala

Guatemala City

IPESA

Avenida Reforma 3-48
Guatemala City
Zona 9
Guatemala
Phone: 2/31667

Indonesia

Jakarta

BERCA Indonesia P. T.
Jl. Abdul Muis 62
P.O. Box 496 Jkt.
Jakarta
Indonesia
Phone: 373 009

CEO(Customer Engineering Organization)—hardware maintenance service available.

SEO(Systems Engineering Organization)—software support available

P(Primary)—Primary SRO

S(Secondary)—Secondary SRO

L(Limited)—The entire product line of HP computers is not presently supported by this SRO. Contact your nearest SRO for office capabilities.

s(Standard)—The SRO provides routine support during the Standard Coverage Hours.

b(Basic)—The SRO provides routine support during the Basic Coverage Hours.

Z(Zones)—The response times and fixed travel charges may vary due to local travel conditions.

Manual Part No. 45260-90005 E0383
Printed in U.S.A.
January 1984

