

OPERATING AND SERVICE MANUAL

PART 1

7970B/7970C

**DIGITAL MAGNETIC TAPE UNITS
OPERATION AND GENERAL INFORMATION**

Serial Numbers Prefixed: 1329

Note

This manual may be backdated to cover earlier versions of the tape unit by incorporating appropriate backdating information from appendix A.

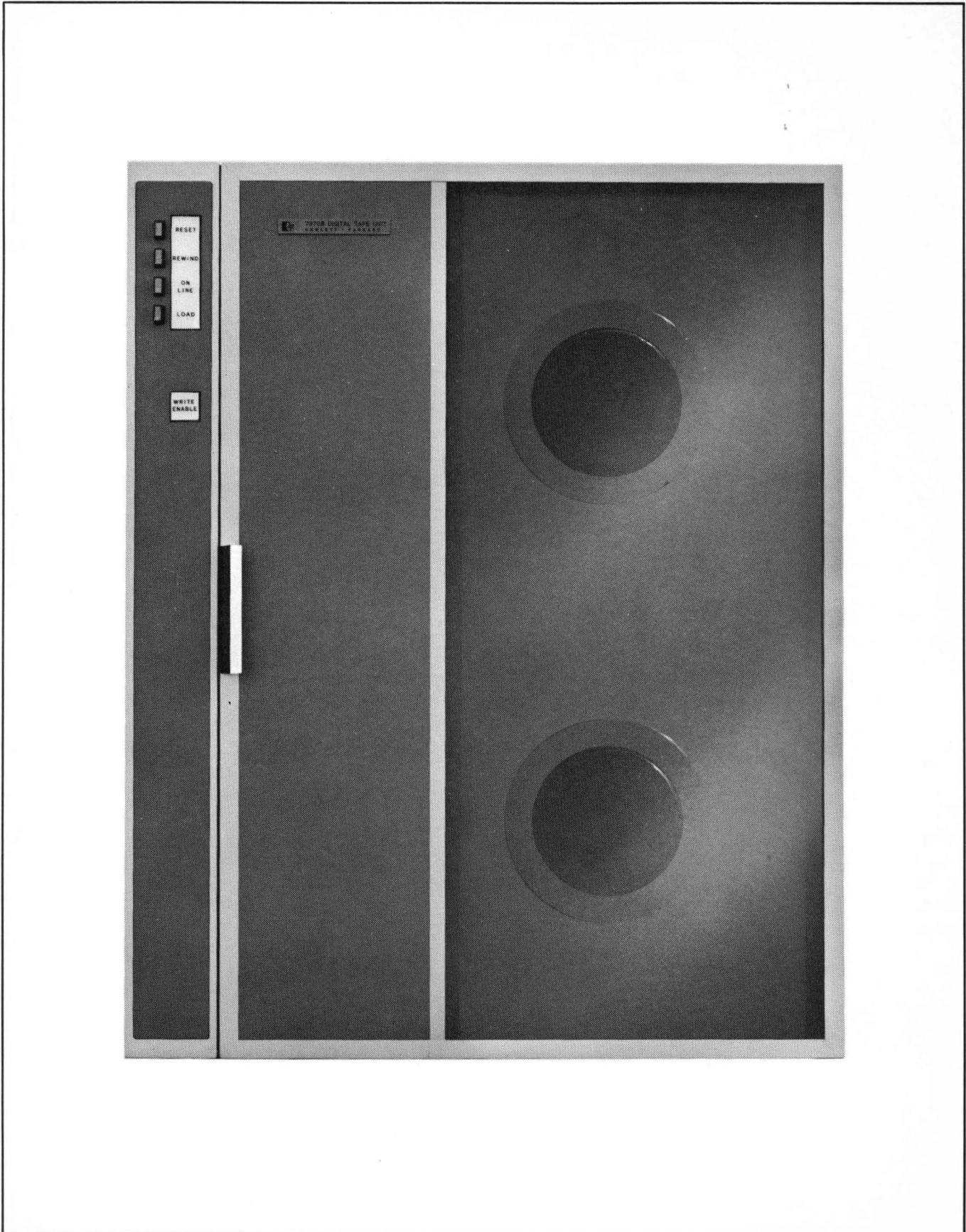

Figure 1-1. Hewlett-Packard 7970B/7970C Digital Magnetic Tape Units

SECTION I DESCRIPTION

1-1. MANUAL SCOPE.

1-2. This manual provides operating and service information for standard product configurations of the HP 7970B/7970C Digital Magnetic Tape Units. (See figure 1-1.) Special product configurations are described by manual supplements attached to this manual. The 7970B is recognized under the component program of the Underwriters Laboratories Inc., and is similar to the 7970C. This manual is applicable to both models.

1-3. This manual is divided into 5 parts. Part 1 contains general information, installation instructions, and operating procedures. Part 1 is applicable to all standard tape units. Part 2 contains a description of the transport, transport theory, performance checkout procedures, adjustment procedures, and an illustrated parts breakdown of the tape transport portion of the tape unit. Part 2 is applicable to all standard tape units. Part 3 contains a description of the read data modules and provides maintenance information for tape units equipped with read data modules. Part 4 contains a description of the write data modules and provides maintenance information for tape units equipped with write data modules. Part 5 contains a description of the read/read (seven- or nine-track read only) modules and provides maintenance information for tape units equipped with read/read modules.

1-4. IDENTIFICATION.

1-5. Each tape unit has a model plate and a serial number plate attached to the transformer assembly. The model plate indicates the tape speed of the unit and the model configuration.

1-6. Table 1-1 lists the standard configuration option numbers that will be shown on the model plate. The model plate also lists factory installed elective options. (Refer to table 1-2.) Special configuration and special factory installed options also appear on the model plate. When special product considerations exist (indicated by alphanumeric option numbers) the information is provided by special modification notices, supplemental to the standard manual.

1-7. The serial number plate contains a two-section serial number (0000A-00000). The first four digits are a serial number prefix. The five-digit number identifies a specific tape unit. If the serial number prefix on the tape unit does not agree with the number on the title pages of this manual, there are differences between the tape unit and the information contained in this manual. These differences are described in manual supplements available at the nearest HP Sales and Service Office.

Table 1-1. Standard Configuration Option Numbers

SPEEDS	R/W	R/O	BASE	TRACKS
10 - 20.9 IPS	121	122	123	NINE
21 - 37.5 IPS	STD	125	126	
37.6 - 45 IPS	127	128	129	
10 - 20.9 IPS	130	131	132	SEVEN
21 - 37.5 IPS	133	134	135	
37.6 - 45 IPS	136	137	138	
10 - 20.9 IPS	-----	139	-----	SEVEN/ NINE (R/R)
21 - 37.5 IPS	-----	140	-----	
37.6 - 45 IPS	-----	141	-----	

Table 1-2. Elective Option Numbers

NUMBER	DESCRIPTION
006	Triple Density Select
007	Unit Select
012	HP Logo
013	Read Parity (Seven- or Nine-Track)
014	Write Parity (Nine-Track)
015	Write Parity (Seven-Track)
016	Door Interlock Switch
017	Black Paint
023	Installation Kit

1-8. Printed-circuit assemblies are identified by a letter, a series code, and a division code on the assembly (e.g. A-1010-42). The letter identifies the revision of the etched trace pattern on the unloaded printed-circuit board. The four-digit series code pertains to the electrical characteristics of the loaded printed-circuit assembly and the positions of the components. The division code identifies the Hewlett-Packard division that manufactured the printed-circuit assembly. If the series numbers of the tape unit printed-circuit assemblies do not agree with the series numbers shown on the schematics and title pages of this manual, there are differences between the tape unit and the information in this manual. These differences are described in manual supplements available at the nearest HP Sales and Service Office.

1-9. DESCRIPTION.

1-10. The tape unit is designed for small computer on-line applications and miscellaneous applications such as plotting table control, key edit system, tape to microfilm, library programs, etc.

1-11. TRANSPORT.

1-12. Transport assemblies are all mounted to the main casting. (See figure 1-2.) The control panel, reel hubs, write/read head assembly, photosensing assembly, tape cleaner, erase head, and tape path components are located on the front of the tape deck mainframe. The write enable assembly, tape deck panel fastener, reel motors, reel servo PC assembly, tension arm assemblies, capstan servo assembly, and capstan servo PC assembly are attached to the interior-side of the main casting.

1-13. TAPE UNIT HOUSING.

1-14. The tape unit housing contains the write/read data modules, the power supply, and the ac fuse receptacles. Figure 1-3 shows the location of the tape unit housing assemblies. The bottom section of the housing rear panel may be removed to gain access to power supply components.

1-15. HEAD ASSEMBLY.

1-16. The head assembly (depending upon options) consists of a write head stack, read head stack, erase head, two tape guides, crosstalk shield head gate, tape cleaner, and base palte. (See figure 1-4.) The two tape guides are used to assure proper positioning and control of tape as it passes over the heads. Before reaching the heads, tape passes over a slotted, block type cleaner which removes any foreign particles. To assure high reliability recording, tape is erased by a high-density, full-tape-width erase head.

1-17. The write/read heads are seven- or nine-track, NRZI standard format which will handle tape packing densities of 200, 556, and 800 cpi within a tape speed range of 10 to 45 ips. A crosstalk shield head gate, positioned directly over the write/read heads, reduces write head to read head crosstalk during a write operation.

1-18. Channel scrambling is accomplished in the head cable. From the reference edge (edge facing the operator), the nine-track channel designations are 5, 7, 3, P, 2, 1, 0, 6, and 4. Seven-track channel designations from the reference edge are 7, 6, 5, 4, 3, 2, and P. The track channel designations are industry compatible.

1-19. WRITE ENABLE ASSEMBLY.

1-20. The write enable assembly is part of the write modules. The complete assembly consists of a mechanical subassembly, a control panel cover, a control panel indicator, and a write enable ring (provided by the supplier) which is installed in the supply reel. The write enable ring must be installed to establish write enable condition. The WRITE ENABLE indicator is illuminated when the supply reel, fitted with a write enable ring, is installed on the supply reel hub. For read-only operation, the write enable ring is removed. This results in a file protect status during which no data can be inadvertently written on the tape during a read operation.

1-21. DENSITY SELECT.

1-22. Density select is an optional feature which is applicable to the read function. Standard units are hard-wired to write or read at a tape packing density of 800 cpi. Units equipped with the density select option permit the operator to select read densities of 200, 556, or 800 cpi. The density select option includes a three-button, interlocked switch with indicators, a printed-circuit assembly (which includes line drivers), and a control panel cover. The density option is field installable.

1-23. UNIT ADDRESS SELECT.

1-24. Address select is an optional feature which is intended for multiple unit operation under computer control. The option includes a five-button interlocked switch with indicators, a printed-circuit assembly, and a control panel cover. This option is field installable.

1-25. SPECIFICATIONS.

1-26. Specifications of the tape unit equipped with read and write modules and all available options are listed in table 1-3.

1-27. OPTIONS.

1-28. Options for the tape unit are field installable but are usually installed at the factory at the time of purchase. Standard configuration-level options and elective options are listed in tables 1-1 and 1-2, respectively.

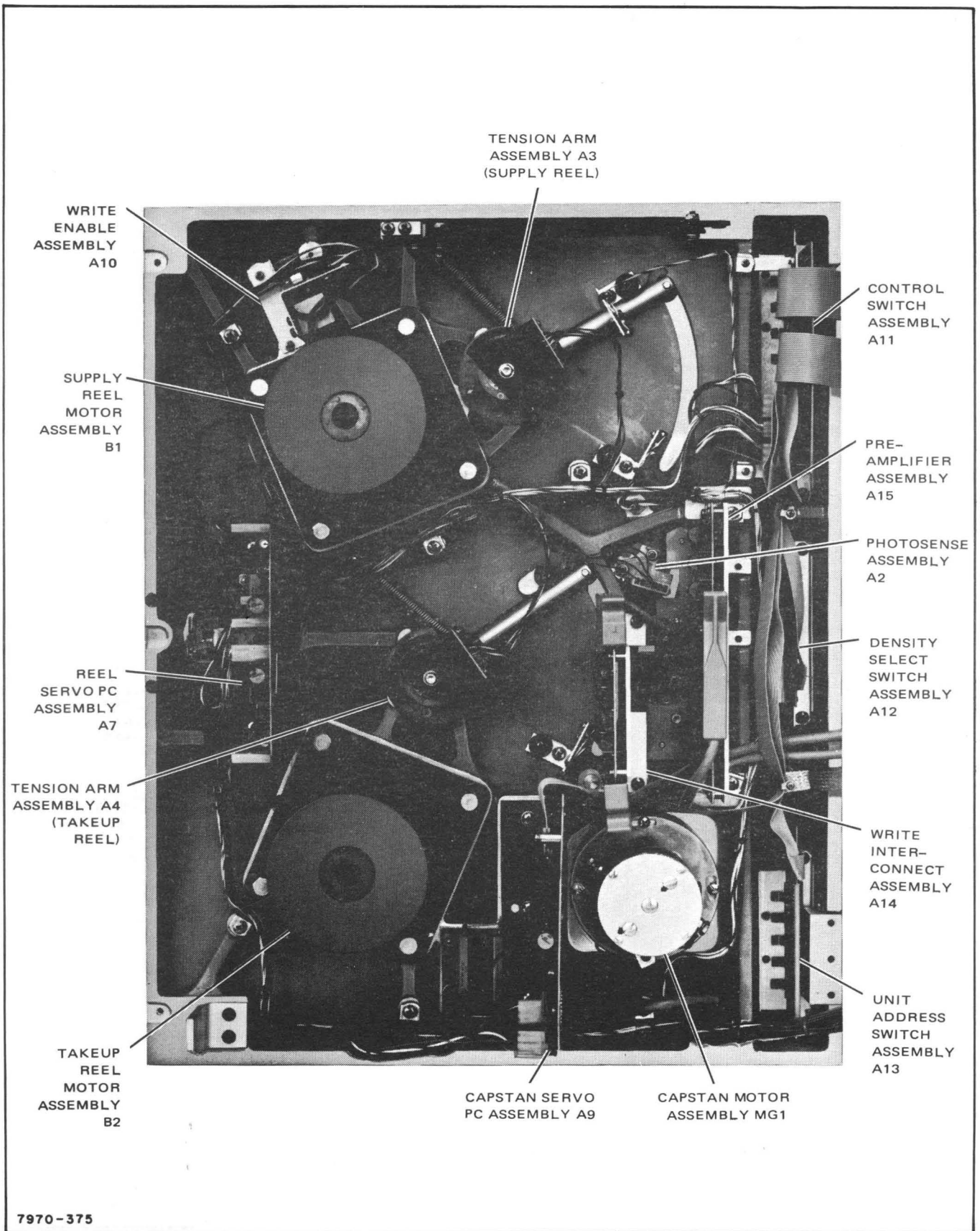

Figure 1-2. Tape Unit Assemblies, Main Casting (Rear View)

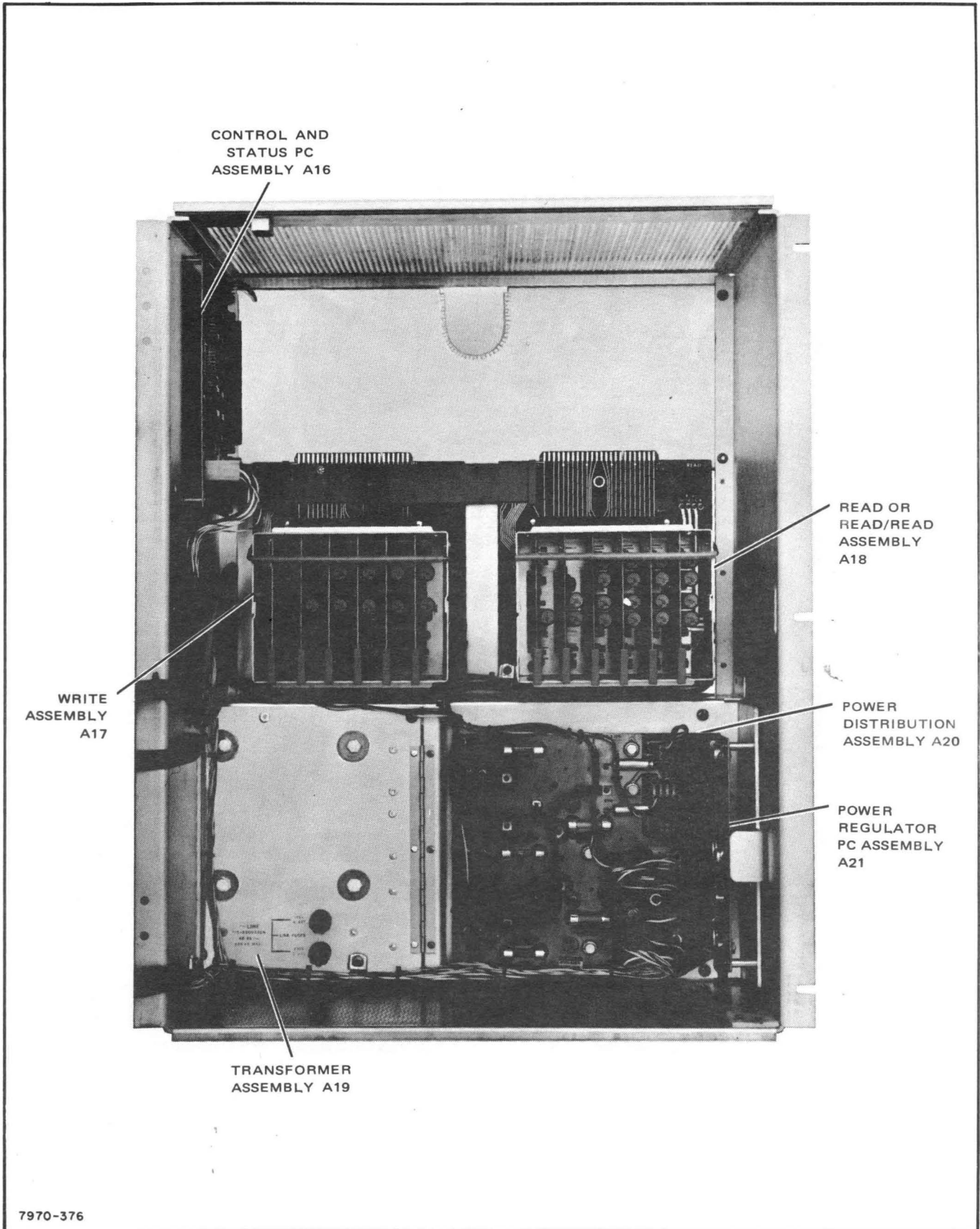

Figure 1-3. Tape Unit Housing Assemblies

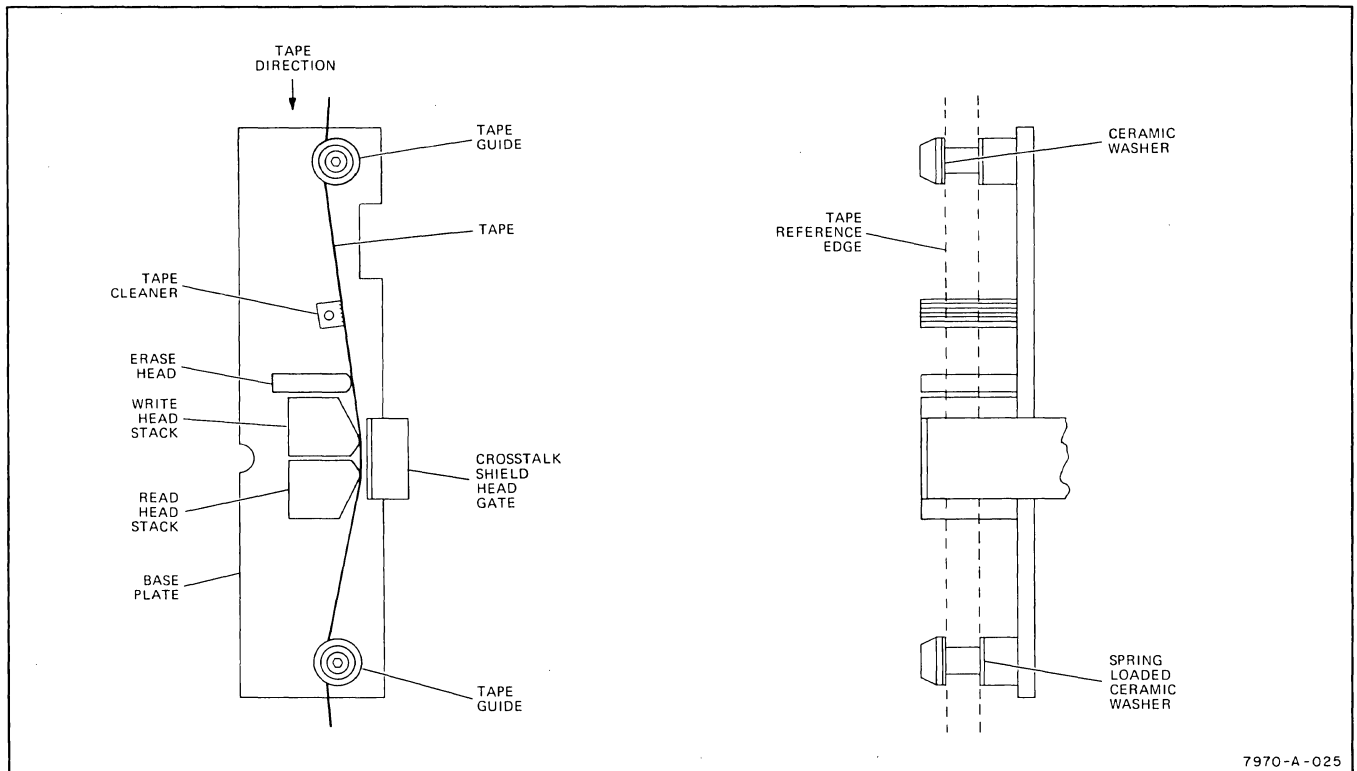

Figure 1-4. Magnetic Tape Head Assembly

1-29. ACCESSORIES FURNISHED.

1-30. The following accessories are furnished with the standard tape unit:

PART NUMBER	DESCRIPTION	QTY
07970-00580	Rack Mounting Bracket	1
2190-0034	. Lockwasher, number 10	7
2680-0103	. Screw, number 10-32, 0.500 inch	3
2680-0116	. Screw, number 10-32, 0.375 inch	4
2680-0129	. Screw, number 10-32, 0.312 inch	4
3050-0002	. Washer, Flat	7
8120-1348	AC Power Cable	1
1490-0738	Magnetic Tape Reel	1
07970-60420	Extender Board	1
07970-61090	Interface Connector	3

Part 1

1-31. ACCESSORIES AVAILABLE.

1-32. The following accessories are available for the tape unit at extra cost:

- a. HP 13190A Multiunit Cable (12.5 feet).
- b. HP 13190B Multiunit Cable (20 feet).
- c. Transport Test Tape, part number 5080-4525 (for seven-track application).
- d. Transport Test Tape, part number 5080-4526 (for nine-track application).
- e. 200 BPI Reference Amplitude Test Tape, part number 5080-4547 (for read only systems).
- f. Write Test Tape, part number 9162-0025 (standard computer grade tape: 3M777 or Memorex MRX 111 on 10.5 inch reels).
- g. Master Alignment Tape, part number 9162-0027.
- h. HP 13191A Control and Status Test Board.
- i. HP 13193A Read Test Board.
- j. HP 13192A Write Test Board.
- k. HP 13012A Read Parity for seven- and nine-tracks.
- l. HP 13014A Write Parity for seven- and nine-tracks.
- m. Rack Mounting Kit, part number 07970-62118.

1-5

Table 1-3. Specifications

TAPE SPEED 10 to 45 ips	MAGNETIC HEAD ASSEMBLY Standard: seven- or nine-track, erase, write and read Gap Scatter (Measured Optically): Read Stack: 150 μ in., maximum Write Stack: 150 μ in., maximum
REEL DIAMETER Up to 10.50 inches (266,7 mm)	SKEW Static Skew: The per channel one-shot deskewing technique is utilized in the write (forward) and read (forward and reverse) circuitry effectively eliminating static skew. Dynamic Skew: $\pm 200 \mu$ in. (read after write), maximum
TAPE (Computer Grade) Width: 0.5 inches (12,7 mm) Thickness: 1.5 mils	HEAD GUIDE SPACING Industry compatible
TAPE TENSION 8.5 oz, nominal	WRITE HEAD TO READ HEAD CROSSTALK <5% (of read signal)
REWIND SPEED 160 ips	READ HEAD CHANNEL TO READ HEAD CHANNEL CROSSTALK <-30 dB
FAST FORWARD 160 ips	BEGINNING-OF-TAPE AND END-OF-TAPE REFLECTIVE STRIP DETECTION Photoelectric, industry compatible
INSTANTANEOUS SPEED VARIATION $\pm 3\%$ (measured bit-to-bit)	OPERATING ENVIRONMENT Ambient Temperature: $+32^{\circ}$ to $+131^{\circ}$ F (0° to 55° C) Relative Humidity: 20 to 80% (non-condensing) Altitude: 10,000 ft (3.048 m)
LONG-TERM SPEED VARIATION $\pm 1\%$	POWER REQUIREMENTS 115 or 230 ($\pm 10\%$) Vac 48 to 66 Hz, single phase 400 VA, maximum (on high line)
FAST FORWARD, FAST REVERSE, START/STOP CHARACTERISTICS Distance: 40 inches, nominal start (25 ips) 69 inches, nominal start (37.5 and 45 ips) 31 inches, nominal stop (37.5 and 45 ips) Time: 0.7 second, maximum	DIMENSIONS Height: 24 inches (609,6 mm) Width: 19 inches (482,6 mm) Depth: 12 inches (304,8 mm) (rack space) Overall Depth: 15.75 inches (391 mm)
START/STOP TIMES 15 ms (at 25 ips) 10 ms (at 37.5 ips) 8.33 ms (at 45 ips)	WEIGHT 130 lb maximum (56.7 kilograms)
START/STOP TAPE TRAVEL 0.187 ± 0.020 inch ($4,7625 \pm 0.508$ mm)	TRANSPORT MOUNTING Vertical: Standard 19 inches (482,6 mm) Retma rack
REEL MOTOR BRAKING Dynamic	
RECORDING MODE NRZI (industry compatible)	

SECTION II

INSTALLATION

2-1. INTRODUCTION.

2-2. This section contains installation information and post-installation checkout procedures. Also included in this section is information pertaining to unpacking, inspection, claims for damage, and site selection.

2-3. UNPACKING AND INSPECTION.

2-4. If the shipping carton is damaged upon receipt, request that the carrier's agent be present when the unit is unpacked. Inspect the unit for damage (cracks, broken parts, etc). If the unit is damaged and fails to meet specifications, notify the carrier and the nearest Hewlett-Packard Sales and Service Office immediately. (Sales and Service Offices are listed at the back of this manual.) Retain the shipping container and the packing material for the carrier's inspection. The Hewlett-Packard Sales and Service Office will arrange for the repair or replacement of the damaged unit without waiting for any claims against the carrier to be settled.

2-5. When unpacking the unit, retain all packing materials and hardware for future use. The following procedures describe how to unpack the unit in order to save all packing materials.

- a. Using a sharp knife or similar tool, cut the top seal of the outer shipping box.
- b. Remove the six toro pads isolating the inner shipping box.
- c. Cut the top seal of the inner shipping box and remove accessory cartons or filler carton.
- d. Remove accessory liner and top pad.
- e. Remove plastic sheet from face of unit.

CAUTION

The unit weighs approximately 130 pounds. Two persons are required to lift the unit from the shipping container.

- f. Remove unit from inner shipping box.
- g. Remove the two number 10-32 screws and washers that secure the tape unit casting to the housing.

2-6. SITE SELECTION.

2-7. The tape unit is designed for operation at sites that are not subject to excessive shocks, excessive vibration, or

wide ranges of ambient temperatures. The unit should be located so as to provide access to both front and rear sections of the cabinet with sufficient room for the maximum swing radius of the cover door and the transport. Convection cooling is provided by perforated panels in the top, bottom, and rear lower panels. No forced air ventilation is required where the exterior ambient temperature does not exceed 131°F and no other heat generating equipment is housed in the cabinet.

2-8. INSTALLATION.

2-9. Installation of the tape unit is limited to mounting the unit in a standard 19-inch rack and connecting interface cabling. The weight of the transport in the open position must be considered and ballast may be required to prevent the rack from tipping. The following procedures describe the installation of the unit in a 19-inch rack.

- a. Remove protective covering from accessory kit and locate four number 10-32 flat-head screws (part number 2680-0116) and rack mounting bracket (part number 07970-00580).
- b. Attach the rack mounting bracket to the left rail of the rack with the four number 10-32 flat-head screws. Orient the rack mounting bracket so that the upper and lower flanges face the inside of the rack. These flanges form a cradle to hold the left (hinged) side of the tape unit.
- c. Place the tape unit into position and using three number 10-32, 0.5-inch machine screws (part number 2680-0103), three flat washers, and three lockwashers, attach the right side of the transport housing to the 19-inch rack.
- d. Using the remaining four number 10-32, 0.312-inch machine screws (part number 2680-0129), flat washers, and lockwashers, secure the left side of the transport housing to the rack mounting bracket.

WARNING

The tape unit power cable is equipped with a three-wire connector. Do not defeat the ground connection by using an adapter or breaking the grounding pin of the connector. Isolating the unit from ground creates a hazardous condition which may result in death or serious injury.

- e. Connect the female polarized connector of power cable W1 to the male power connector of the tape unit. Route the power cable to the site power outlet.

2-10. CABLES AND CONNECTORS.

2-11. There are three interface mating connectors. Each is specifically associated with:

- a. Control and Status.
- b. Write Data.
- c. Read Data.

The male portions of these connectors are presented to the interface cables, via supplied mating connectors, as etched sections of printed-circuit assemblies. These assemblies are located within the rear section of the tape unit. (See figure 2-1.

2-12. Three female mating connectors are supplied; each has a 48-pin (24 active line) capability. These mating connectors are intended to be directly connected to the users interfacing cables. Strain relief hardware is also provided. Tables 2-1, 2-2, and 2-3 list the pin assignments and line names. These lines are described in tables 2-4, 2-5, and 2-6.

2-13. The suggested maximum cable length is 20 feet from connector pin to connector pin. The interfacing cable should employ one set of twisted pairs for each input/output (I/O) line function, with one of the pair being used for the active I/O line, the other being used for terminal grounding at both ends of the cable to reduce the magnitude of intercable crosstalk. Unless otherwise specified, all wires should be 26 AWG, minimum, not less than one twist per inch, with a minimum insulation thickness of 0.01 inch. Figure 2-2 shows interface connector details and describes fabrication of an interface cable.

2-14. MULTIPLE UNIT INSTALLATION.

2-15. The three interface connector boards are manufactured with parallel connectors. This allows up to four tape units to be utilized from one controller. Figure 2-3 shows a typical multiple unit installation. HP 13190A and 13190B Multiunit Cable Accessory Kits are available for multiple unit installation.

2-16. The unit select address is operator selectable from the operator control panel, (if the tape unit has the unit select option). Otherwise, the unit address is jumper selectable on the control and status PC assembly.

2-17. INPUT/OUTPUT LINE TRANSMITTERS AND RECEIVERS.

2-18. The tape unit interface I/O transmitter and receiver electrical parameters are shown and described in figure 2-4.

2-19. WAVEFORM AND EVENT TIMING.

2-20. Figures 2-5 and 2-6 show the write and read timing. The read-after-write verification time is approximately 6.0 milliseconds or:

$$\frac{\text{Head Spacing}}{\text{Velocity}}$$

2-21. CHECKOUT PROCEDURES.

2-22. After the unit is installed and interface connections are completed, visually inspect the installation. Ensure that the power source is adequate and that all cables are properly anchored. Refer to section III for a description of all operating controls and indicators. Perform the checkout procedures described in section III to ensure that the unit is operational.

2-23. RESHIPMENT.

2-24. If the tape unit or any part of the unit is to be shipped to Hewlett-Packard for service or repair, attach a tag to the item identifying the owner and indicating the service or repair to be accomplished. Include the information shown on the model plate and serial number of the unit.

2-25. When packing the unit for shipment, observe the following precautions and use the original packing materials.

- a. Ensure that the two number 10-32, 0.5-inch machine screws (part number 2680-0103) and washers (part number 3050-0002) are installed in the holes provided in the casting. These screws prevent the casting from opening away from the housing.

- b. Ensure that the inner carton is in good condition and that the liner (part number 9220-1660) is in position at the bottom of the inner carton. The slots in the liner allow the use of a shipping sling.

- c. Place the unit into the inner carton with the reel cover facing up. Ensure that the casting weight is evenly distributed over the liner surface. If a shipping sling is used to lower the unit into the carton, be sure the webbing is located at the slots of the inner liner.

- d. Place the plastic sheet over the unit to protect the window surface.

- e. Place the top pad into position. If the unit is to be shipped without accessories, fill the remaining space with a filler carton (part number 9211-1647) or other similar filler. Do not fill this space with loose fill. Solid mass is required for adequate protection.

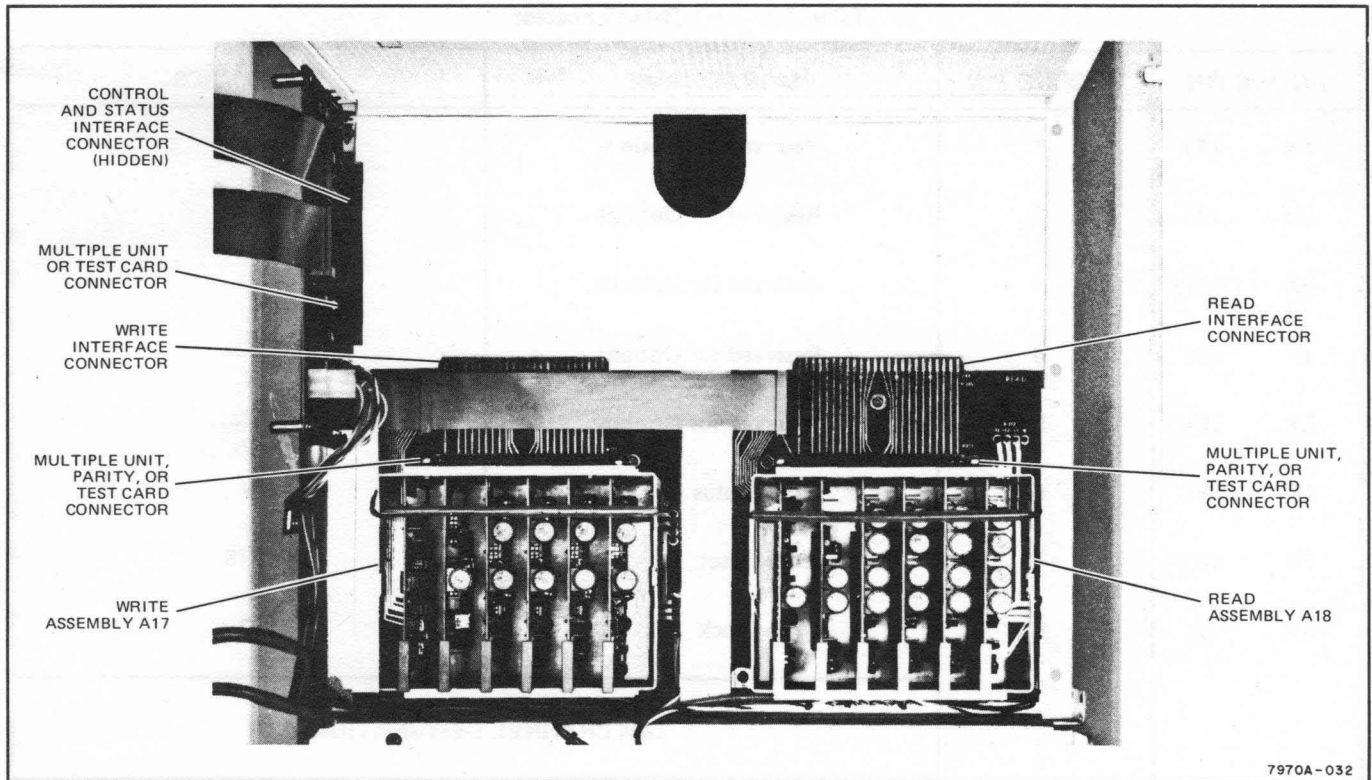

Figure 2-1. Tape Unit Interface Connectors

Table 2-1. Control and Status Connector

ACTIVE PIN	GROUND PIN	SIGNAL NAME	MNEMONIC
1X (A)	1	On-Line Status	SL
2X (B)	2	Load Point Status	SLP
3X (C)	3	Rewind Status	SRW
4X (D)	4	End of Tape Status	SET
5X (E)	5	Ready Status	SR
6X (F)	6	File Protect Status	SFP
7X (H)	7	Density 800 Status	SD8
8X (J)	8	Density 556 Status	SD5
9X (K)	9	Density 200 Status	SD2
10X (L)	10	Select Unit 3	CS3
11X (M)	11	Select Unit 2	CS2
12X (N)	12	Select Unit 1	CS1
13X (P)	13	Select Unit 0	CS0
14X (R)	14	Rewind Command	CRW
15X (S)	15	Off-Line Command	CL
16X (T)	16	Forward Command	CF
17X (U)	17	Reverse Command	CR
18X (V)	18	High Speed Command	CH
19X (W)	19	Set Write Command	WSW
20X (X)	20	Reserved for Options and Spares	-----
through	through	↑ ↓	-----
24X (BB)	24	Reserved for Options and Spares	-----

Table 2-2. Write Data Connector

ACTIVE PIN		GROUND PIN	SIGNAL NAME		MNEMONICS	
1X	(A)	1	Reserved for Options		-----	
2X	(B)	2	Reserved for Options		-----	
3X	(C)	3	Reserved for Options		-----	
4X	(D)	4	Reserved for Options		-----	
5X	(E)	5	Reserved for Options		-----	
6X	(F)	6	Write Status		SW	
7X	(H)	7	Write Reset		WRS	
8X	(J)	8	Write Clock		WC	
IBM CHANNEL DESIGNATIONS						
			NINE-TRACK	SEVEN-TRACK	NINE-TRACK	SEVEN-TRACK
9X	(K)	9	Write Data P	Write Data C	WDP	WDC
10X	(L)	10	Write Data 0	-----	WD0	-----
11X	(M)	11	Write Data 1	-----	WD1	-----
12X	(N)	12	Write Data 2	Write Data B	WD2	WDB
13X	(P)	13	Write Data 3	Write Data A	WD3	WDA
14X	(R)	14	Write Data 4	Write Data 8	WD4	WD8
15X	(S)	15	Write Data 5	Write Data 4	WD5	WD4
16X	(T)	16	Write Data 6	Write Data 2	WD6	WD2
17X	(U)	17	Write Data 7	Write Data 1	WD7	WD1
18X	(V)	18	Reserved for Options and Spares		-----	
through		through			-----	
24X	(BB)	24	Reserved for Options and Spares		-----	

Table 2-3. Read Data Connector

ACTIVE PIN		GROUND PIN	SIGNAL NAME		MNEMONICS	
1X	(A)	1	Reserved for Options and Spares		-----	
2X	(B)	2	Reserved for Options and Spares		-----	
3X	(C)	3	Reserved for Options and Spares		-----	
4X	(D)	4	Reserved for Options and Spares		-----	
5X	(E)	5	Reserved for Options and Spares		-----	
6X	(F)	6	Reserved for Options and Spares		-----	
7X	(H)	7	Reserved for Options and Spares		-----	
8X	(J)	8	Read Clock		RC	
IBM CHANNEL DESIGNATIONS						
			NINE-TRACK	SEVEN-TRACK	NINE-TRACK	SEVEN-TRACK
9X	(K)	9	Read Data P	Read Data C	RDP	RDC
10X	(L)	10	Read Data 0	-----	RD0	-----
11X	(M)	11	Read Data 1	-----	RD1	-----
12X	(N)	12	Read Data 2	Read Data B	RD2	RDB
13X	(P)	13	Read Data 3	Read Data A	RD3	RDA
14X	(R)	14	Read Data 4	Read Data 8	RD4	RD8
15X	(S)	15	Read Data 5	Read Data 4	RD5	RD4
16X	(T)	16	Read Data 6	Read Data 2	RD6	RD2
17X	(U)	17	Read Data 7	Read Data 1	RD7	RD1
18X	(V)	18	Reserved for Options and Spares		-----	
through	through				-----	
24X	(BB)	24	Reserved for Options and Spares		-----	

Table 2-4. Detailed Description of I/O Lines, Status, and Motion Control Connector

I/O LINE	DESCRIPTION	SIGNAL TYPE	SIGNAL DIRECTION
STATUS a. ON-LINE (SL = STATUS ON-LINE)	Acknowledges that the selected tape unit has been manually placed in an on-line condition.	Level	Output
b. READY (SR = STATUS READY)	Indicates that the tape unit is selected, is on-line, the initial loading sequence is complete, and the tape unit is not rewinding.	Level	Output
c. LOAD POINT (SLP = STATUS LOAD POINT)	Indicates that the tape unit is selected, is on-line, and the tape is positioned at the load point reflective strip.	Level	Output
d. DENSITY STATUS (SD = STATUS DENSITY) NOTE: Three individual lines SD2, SD5, and SD8	Indicates the manual setting of a tape unit density switch: 220, 556, 800 CPI. Only one density at a time can be asserted from a selected and on-line tape unit.	Level	Output
e. REWIND (SRW = REWIND STATUS)	Indicates that the selected and on-line tape unit is engaged in a rewind operation. This status remains true until the tape is positioned at the load point reflective strip.	Level	Output
f. FILE PROTECT (SFP = STATUS FILE PROTECT)	Indicates that the selected and on-line tape unit is not write enabled (write ring is not present in the file reel).	Level	Output
g. END-OF-TAPE (SET = STATUS END OF TAPE)	Indicates that an end-of-tape reflective strip has passed under the photosense head of a selected and on-line tape unit. Assertion is maintained until cancellation of the end-of-tape condition by the passage of the reflective strip in the reverse direction.	Level	Output
FUNCTION COMMANDS a. SELECT (CS = COMMAND SELECT) NOTE: Four individual lines for units 0, 1, 2, and 3	Selects a particular on-line tape unit from a group connected to a common interface cable.	Level	Input to tape unit
b. OFF-LINE (CL = COMMAND OFF-LINE)	Assertion of this line clears the write condition and terminates the on-line condition of the selected tape unit. Assertion should be maintained until acknowledged by the negation of the on-line status.	Level	Input to tape unit

Table 2-4. Detailed Description of I/O Lines, Status, and Motion Control Connector (Continued)

I/O LINE	DESCRIPTION	SIGNAL TYPE	SIGNAL DIRECTION
<p>FUNCTION COMMANDS (Continued)</p> <p>c. SET WRITE (WSW = WRITE SET WRITE)</p>	<p>The assertion transition of CF causes the WSW line to be sampled following a 20 μs maximum delay period.</p> <p>Assertion transition of the WSW line enables the setting of the selected and on-line tape unit's write condition, provided the tape unit is ready and write enabled.</p> <p>Negation of the WSW line enables the clearing of the tape unit's write condition.</p> <p>The desired logic level of WSW shall be maintained for not less than 20 μs after the assertion edge of CF.</p>	Level	Input to tape unit
<p>MOTION COMMANDS</p> <p>a. FORWARD (CF = COMMAND FORWARD)</p>	<p>Providing the tape unit is selected, and ready, this command causes tape to be driven in the forward direction.</p>	Level	Input to tape unit
<p>b. REVERSE (CR = COMMAND REVERSE)</p>	<p>When asserted, clears the write condition and causes the tape to be driven in the reverse direction, provided that the tape unit is selected, and ready. Load point status inhibits the response to this command.</p>	Level	Input to tape unit
<p>c. REWIND (CRW = COMMAND REWIND)</p>	<p>Clears the write command on the selected tape unit and initiates a rewind operation, provided that the tape unit is ready, and not at load point. Tape is positioned at load point at the end of this operation. Assertion should be maintained until acknowledged by rewind status. (Minimum 2 μs.)</p>	Level	Input to tape unit
<p>d. HIGH SPEED (CH = COMMAND HIGH SPEED)</p>	<p>When asserted with forward or reverse on a selected and ready tape unit, will cause tape speed to accelerate to 160 ips.</p>	Level	Input to tape unit

Table 2-5. Detailed Description of I/O Lines, Write Data Connector

I/O LINE	DESCRIPTION	SIGNAL TYPE	SIGNAL DIRECTION
<p>STATUS</p> <p>a. WRITE STATUS (SW = STATUS WRITE)</p>	<p>Indicates that the selected tape unit is write enabled and current is flowing in the write and erase heads.</p>	<p>Level</p>	<p>Output from tape unit</p>
<p>DATA TRANSMISSION</p> <p>a. WRITE DATA (WD = WRITE DATA)</p> <p>WD0 thru WD7, WDP</p> <p>NOTE: Refer to write data connector for channel designation.</p>	<p>These lines (any one of nine lines) receive data to be recorded on tape as a character and must be electrically stable at assertion transition time of write clock and for 2 μs, minimum, thereafter.</p>	<p>Level</p>	<p>Input</p>
<p>b. WRITE CLOCK (WC = WRITE CLOCK)</p>	<p>The assertion transition of this pulse causes the character, represented by the write data lines, to be written on tape. The tape unit must be in the write condition and the assertion of the write clock must be maintained for a minimum of 2 μs.</p>	<p>Level</p>	<p>Input</p>
<p>c. WRITE RESET (WRS = WRITE RESET)</p>	<p>The assertion transition causes the LRCC character to be written on tape, provided the unit is in the write mode. Assertion must be maintained for a minimum of 2 μs.</p>	<p>Pulse</p>	<p>Input</p>

Table 2-6. Detailed Description of I/O Lines, Read Data Connector

I/O LINE	DESCRIPTION	SIGNAL TYPE	SIGNAL DIRECTION
<p>READ DATA TRANSMISSION</p> <p>a. READ DATA (RD = READ DATA)</p> <p>RD0 thru RD7, RDP</p> <p>NOTE: Refer to read data connector for channel designation.</p>	<p>These lines (any one of nine lines) detected characters read from the tape and present them to the interface.</p> <p>The read data lines are settled at the assertion transition time of read clock, and remain settled until 1 μs, maximum, before the next read clock.</p>	<p>Level</p>	<p>Output</p>
<p>b. READ CLOCK (RC = READ CLOCK)</p>	<p>Indicates that a character has been read from tape and is present on the read data lines. Assertion time is 2 μs, minimum, 3 μs, maximum.</p>	<p>Pulse</p>	<p>Output</p>

CABLE AND CONNECTOR PARTS

ITEM	DESCRIPTION	PART NO.
1	CONNECTOR HOOD	5040-6071
2	SELF-TAPPING SCREW (A)	0624-0098
3	MOUNTING BLOCK	5040-6072
4	SELF-TAPPING SCREW (B)	0624-0098
5	PAN-HEAD SCREW (4-40 x .562")	-----
6	HEX NUT (4-40 x .187")	-----
7	CONNECTOR, 48 PIN	1251-2518
8	CABLE CLAMP	5040-6003 OR 5040-6004
9	SET SCREW	3030-0143
10	CABLE, 24 TWISTED PAIR	8120-0951 OR EQUIVALENT

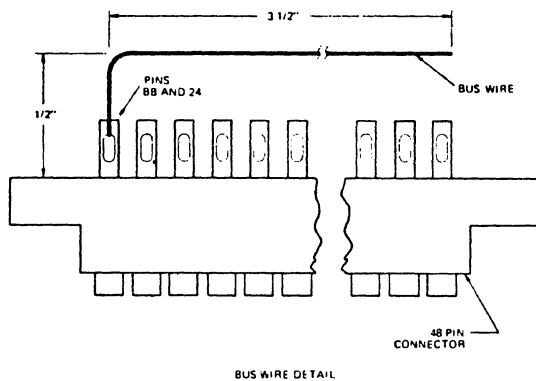
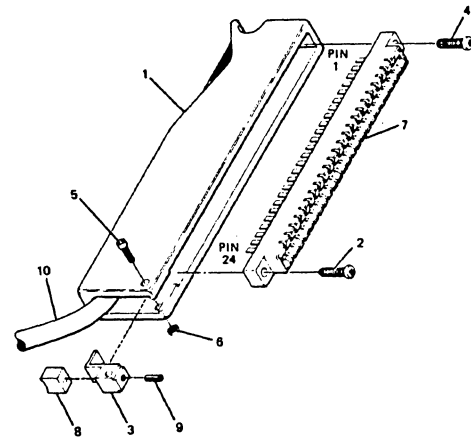

BUS WIRE DETAIL

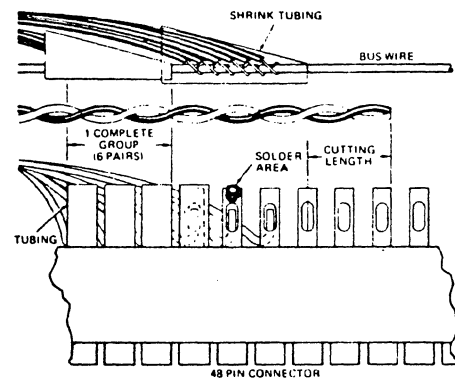

CABLE FABRICATION

To fabricate the interconnect cable refer to the above information and proceed as follows:

- a. Insert approximately 10 inches of cable (2) into connector hood (1).
- b. Strip the outer jacket of the cable back 5 inches.
- c. Prepare a bus wire from 22-gauge bare-copper wire and solder it to pins BB and 24 of the connector (7) as shown in bus wire detail above.
- d. Divide the 24 twisted pairs into groups of six pairs each.
- e. Starting at the end of the 48-pin connector nearest pins BB and 24, connect the first six pairs as follows:
 - (1) Solder the six signal (white) wires to the respective pins on the connector and insulate each pin with shrink tubing as shown above.
 - (2) Solder the six ground (black) wires to the bus wire and insulate with shrink tubing as shown above.
- f. Repeat steps (1) and (2) with the remaining groups of wires until all wires are soldered to the connector and insulated.
- g. Trim off any excess bus wire and install the 48-pin connector (3) in the connector hood (1) using the two self-tapping screws (2 and 4).
- h. Install cable clamp (8) and mounting block (3) and tighten in place with the setscrew (9).

7979-451

Figure 2-2. Interconnection Cable Fabrication

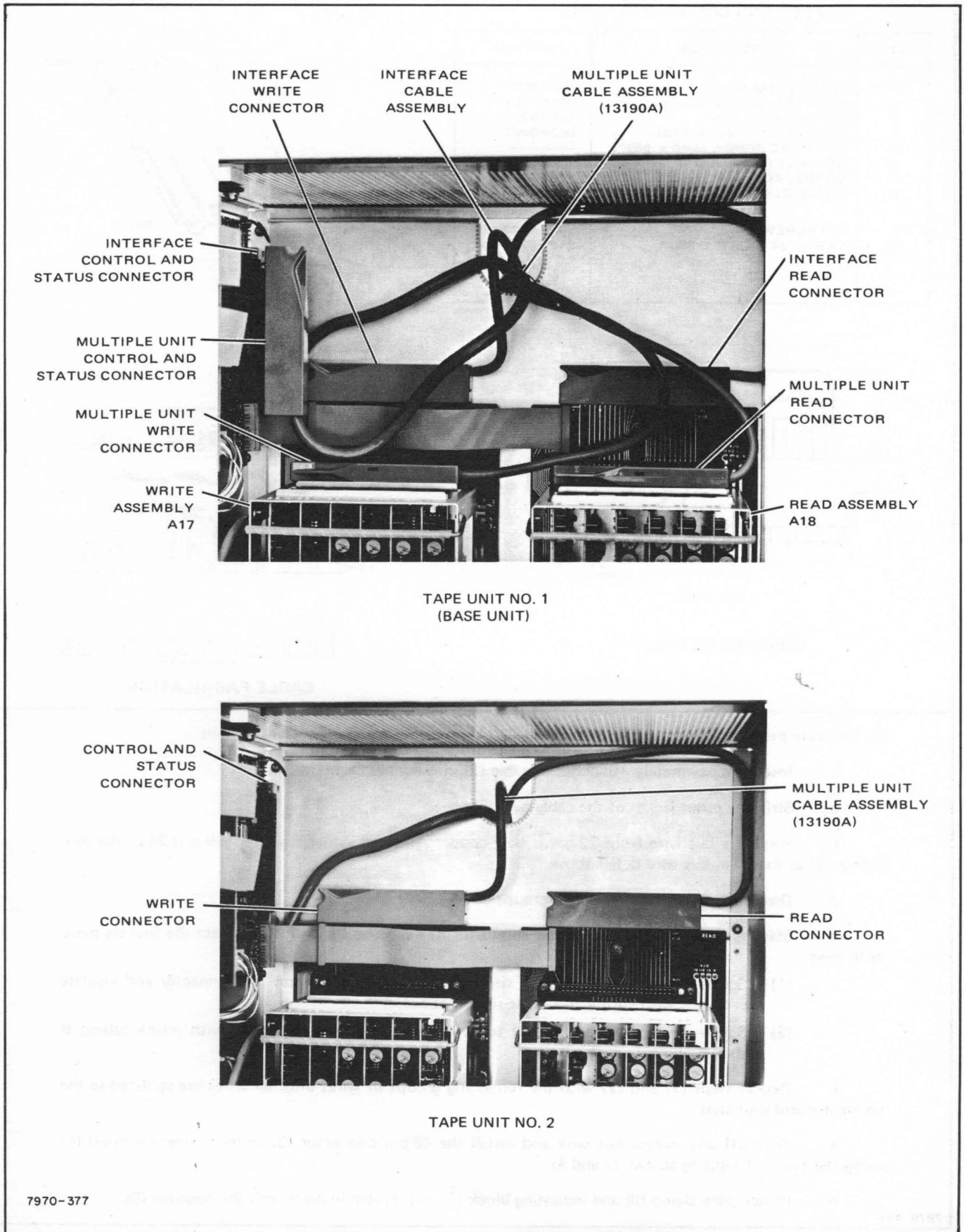

Figure 2-3. Multiple Unit Installation

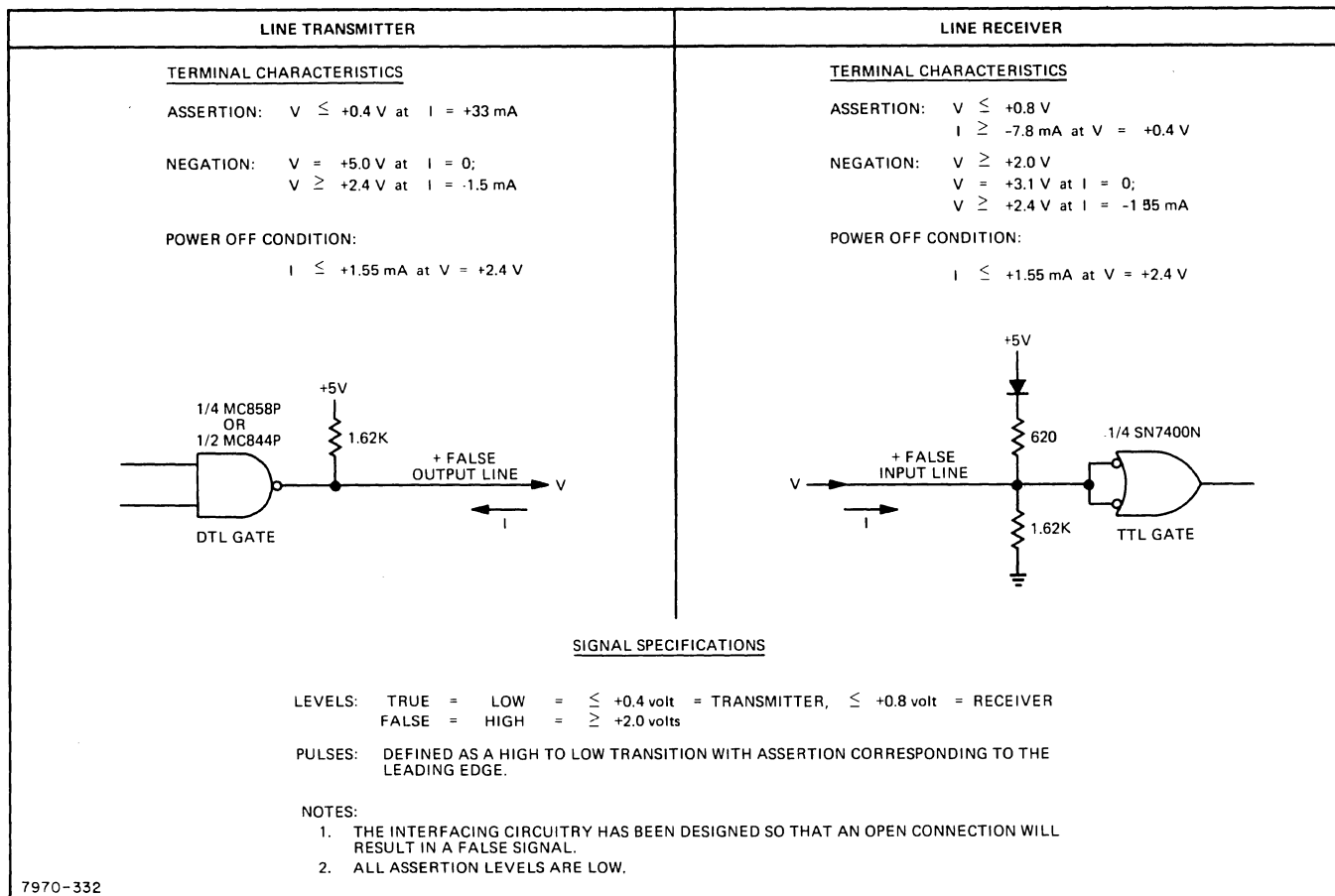

Figure 2-4. Electrical Parameters of the I/O Line Transmitters and Receivers

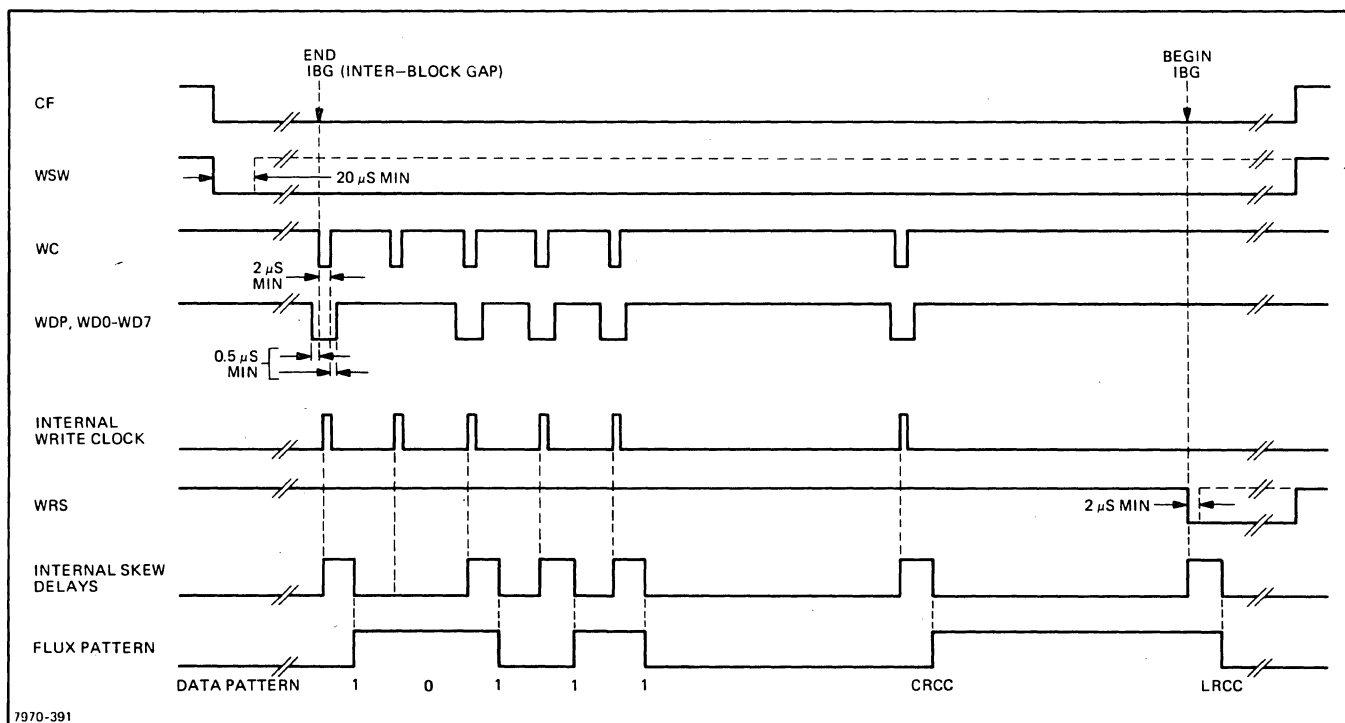

Figure 2-5. Write Waveforms

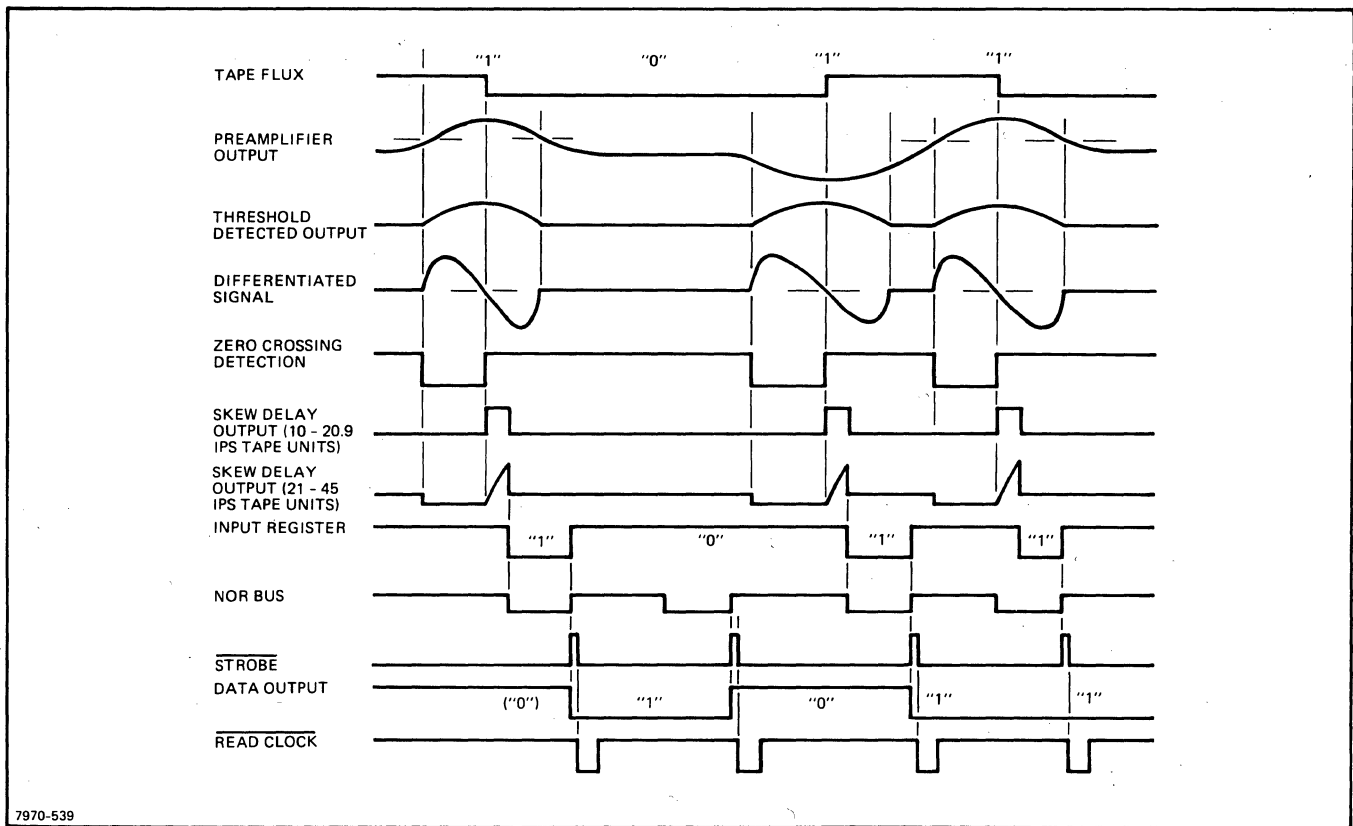

Figure 2-6. Read Waveforms

SECTION III

OPERATION

3-1. INTRODUCTION.

3-2. This section describes all operating controls and indicators of the tape unit. Information pertaining to magnetic tape, operation of the unit, checkout procedures, and operator maintenance is also included.

3-3. The tape unit will normally function as a peripheral unit of a computer. The operator will apply power to the unit, load tape, select density (optional), select unit address (optional), and place the unit on-line. The operator must also correct for power failure and unload the tape. The operator may rewind manually if required.

3-4. The write/read functions and the on-line tape control functions are computer programmable. The capability to handle seven or nine tracks, read-after-write, or read-only are dependent upon unit equipped head options and associated logic.

3-5. Operator control of off-line functions is limited to the built-in manual controls, equipment options, and user interfaced provisions.

3-6. OPERATING CONTROLS AND INDICATORS.

3-7. Figure 3-1 shows the location of operating controls and indicators, and table 3-1 defines the controls and indicators.

3-8. SELECTION AND CARE OF TAPE.

3-9. TAPE SELECTION.

3-10. Use computer grade tape, 0.5-inch wide and 1.5-mils thick.

3-11. CARE OF MAGNETIC TAPE.

3-12. Tape and reel should be handled carefully. Avoid unnecessary handling of tape to minimize tape contamination. Tape should be kept in the supplier's container when not in use, preferably stacked on end. Avoid exposure to strong magnetic fields or excessive heat (such as temporary

storage in direct sunlight). When handling reels, support the reel at the hub flange to minimize reel warpage.

3-13. TAPE STORAGE.

3-14. Store tape at operating room temperature (60° to 80° F, 15° to 25° C, 60% humidity) with reels on edge in the original boxes, book-shelf style. If reels are stored flat, avoid stacking. Run the tape occasionally to preserve its resistance to storage conditions. If tape is stored in an environment different from the using environment, allow 12 to 24 hours for the tape to reach environmental conditions before using.

3-15. INSTALLATION/REMOVAL OF WRITE ENABLE RING.

3-16. The write enable assembly is part of the write/read optional feature. Loaded tape reels from the tape supplier come fitted with a write enable ring. For write/read operation, the write enable ring is installed. For read-only operation, the write enable ring is removed. With the write enable ring removed, no inadvertent recording on the tape is possible. This, in essence, is a file protect feature.

3-17. INSTALLATION OF BOT AND EOT PHOTOSENSE TABS.

3-18. Install EOT (end-of-tape) and BOT (beginning-of-tape; also called load point) tabs as indicated in figure 3-2. The ten-foot (tab to end-of-tape) requirement is minimum. Handle tape with clean hands and avoid excessive handling in recording area. BOT and EOT tabs are installed by the tape supplier. However, if the tabs come loose or if new tabs are required because of tape breakage, they may be installed by the operator. Use IBM tabs (part number 352407) or equivalent. These tabs are made with a pressure-sensitive adhesive which is attached to the shiny side (non-oxide) of the tape.

3-19. TAPE REEL INSTALLATION.

3-20. Check supply reel before installing. Examine reel for warpage or accumulation of dust. Clean reel if dirty. Do not use damaged or warped reel. Open cover door and verify that transport area is clean. Pull supply hub locking lever outward. Handle supply reel by the hub flange, position on hub, press firmly and seat reel to hub. Keep even pressure on reel flange and seat quick disconnect lever.

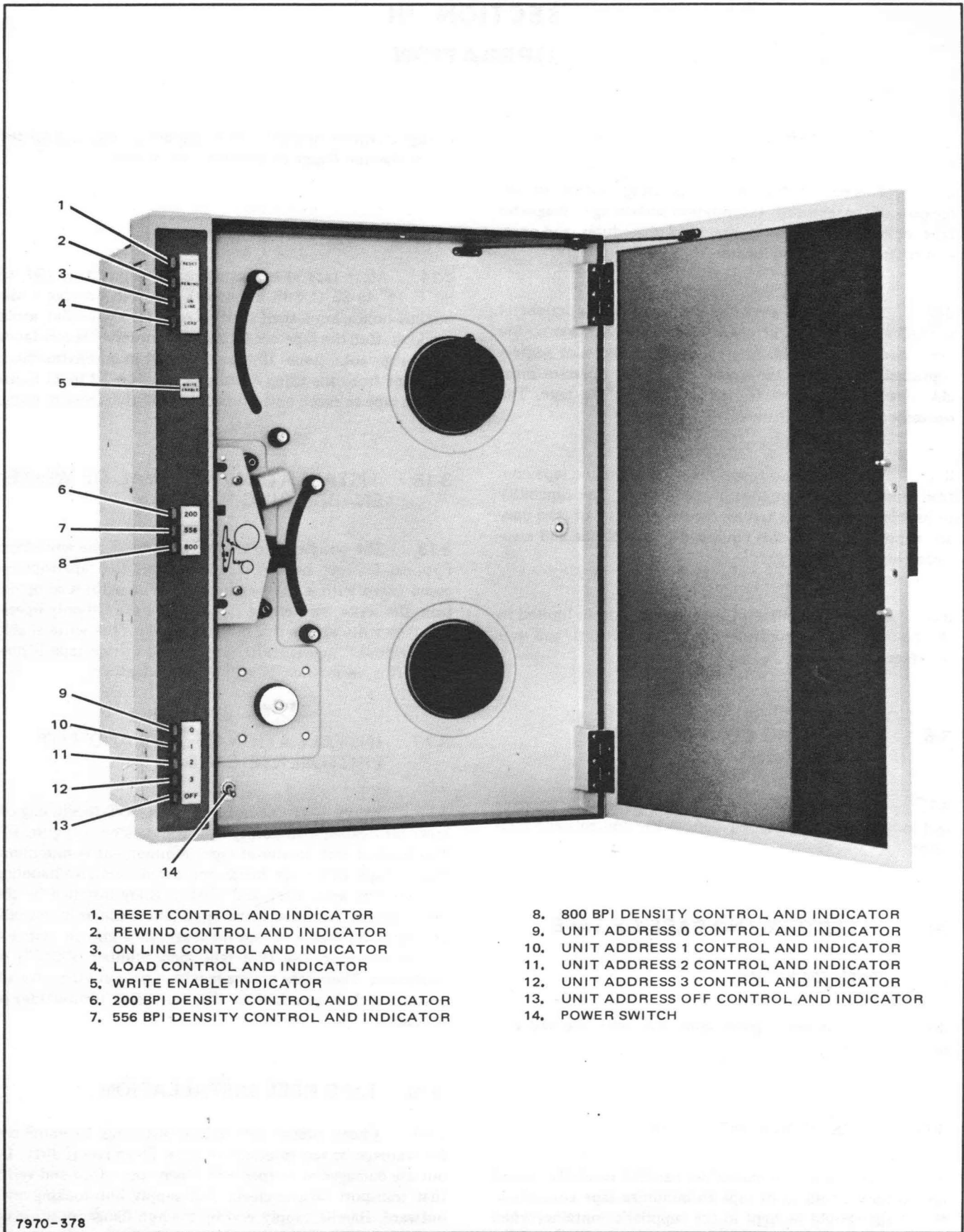

- 1. RESET CONTROL AND INDICATOR
- 2. REWIND CONTROL AND INDICATOR
- 3. ON LINE CONTROL AND INDICATOR
- 4. LOAD CONTROL AND INDICATOR
- 5. WRITE ENABLE INDICATOR
- 6. 200 BPI DENSITY CONTROL AND INDICATOR
- 7. 556 BPI DENSITY CONTROL AND INDICATOR

- 8. 800 BPI DENSITY CONTROL AND INDICATOR
- 9. UNIT ADDRESS 0 CONTROL AND INDICATOR
- 10. UNIT ADDRESS 1 CONTROL AND INDICATOR
- 11. UNIT ADDRESS 2 CONTROL AND INDICATOR
- 12. UNIT ADDRESS 3 CONTROL AND INDICATOR
- 13. UNIT ADDRESS OFF CONTROL AND INDICATOR
- 14. POWER SWITCH

7970-378

Figure 3-1. Tape Unit Controls and Indicators

Table 3-1. Tape Unit Controls and Indicators

CONTROLS AND INDICATORS	TYPE	FUNCTIONS
RESET	Momentary pushbutton switch with indicator.	<p>a. Press to:</p> <ul style="list-style-type: none"> (1) Stop tape travel in any mode. (2) Remove unit from on-line status. (3) Halt load point search if operator loads beyond load point. <p>b. Lamp illuminates indicating that unit is in manual mode.</p>
REWIND	Momentary pushbutton switch with indicator.	<p>a. Rewind places unit in rewind mode. Tape rewinds at 160 ips until BOT tab is sensed. The photosense signal to motion control logic initiates a load point search; tape stops at BOT reflective strips and LOAD lamp illuminates.</p> <p>b. Lamp illuminates indicating that unit is in rewind mode.</p> <p>c. Operational only from RESET. RESET indicator stays illuminated. Will override a Load command.</p> <p>d. Rewind is terminated by pressing RESET, or by logic when BOT tab is sensed.</p> <p>e. To unload tape: When tape is at load point, press REWIND pushbutton and hold momentarily until tape passes BOT tab and release.</p>
ON-LINE	Momentary pushbutton switch with indicator.	<p>a. Switches unit to on-line status when:</p> <ul style="list-style-type: none"> (1) Tape has completed a BOT search or search has been stopped by a Reset command. (2) ON-LINE pushbutton is pressed. <p>b. Lamp illuminates indicating that unit is available to processor.</p>
LOAD	Momentary pushbutton switch with indicator.	<p>a. Press pushbutton and release:</p> <ul style="list-style-type: none"> (1) Establishes tape tension. (2) Logic initiates load point (BOT) search. <p>b. Press RESET to terminate load point search. (Rewind will override load point search.)</p>

Table 3-1. Tape Unit Controls and Indicators (Continued)

CONTROLS AND INDICATORS	TYPE	FUNCTIONS
LOAD (Continued)		c. When transport stops at load point, unit will go to on-line status if ON-LINE pushbutton has been pressed during LOAD operation.
		d. Places reel motors under control of the tension arm photo-sense circuits.
		e. Lamp illuminates, indicating that tape is at load point.
		f. WRITE ENABLE indicator will also be illuminated if that operational feature is installed (and supply reel is fitted with a write enable ring).
WRITE ENABLE	Indicator	a. Available with write option package.
		b. When LOAD is pressed, indicator illuminates indicating that write enable ring is installed in supply reel.
		c. Enables power to be applied to write system.
DENSITY SELECT	Interlocked pushbutton switches with indicators.	a. Optional feature.
		b. Allows selection of read densities: 200, 556, and 800 cpi.
		c. Indicator illuminates indicating density selected.
		d. When unit is not equipped with a density select option, logic will normally be set for 800 cpi.
ADDRESS SELECT	Interlocked pushbutton switches with indicators.	a. Optional feature.
		b. When one of four switches is pressed and the indicator is illuminated, the unit is assigned an address which must be selected by the processor to control the tape unit if the unit is in on-line status.
		c. When the OFF switch is pressed, all four address switches are disabled and the OFF indicator is illuminated.
		d. In OFF position unit will not respond to any incoming signal.
Power	ON-OFF toggle switch.	a. Applies ac voltage to transformer primary circuit.
		b. Switches both sides of the ac line.

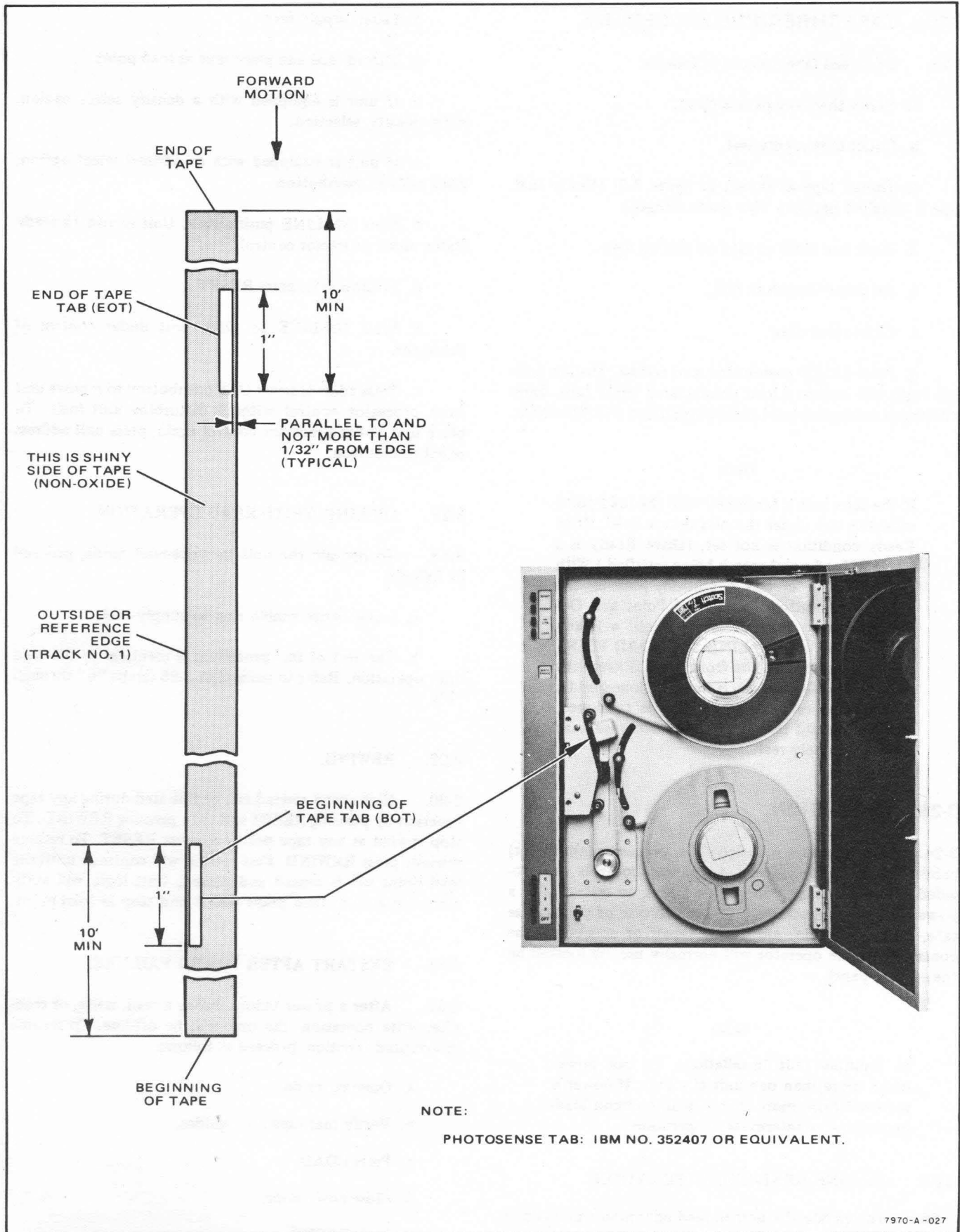

Figure 3-2. Installation of Photosense Tabs

3-21. TAPE THREADING PROCEDURE.

3-22. To thread tape proceed as follows:

- a. Verify that tape path is clean.
- b. Install tape supply reel.
- c. Thread tape as shown in figure 3-3. (Verify that tape is installed between tape guide flanges.)
- d. Work two turns of tape on takeup reel.
- e. Set power switch to ON.
- f. Close cover door.
- g. Press LOAD pushbutton and release. Motion control logic will initiate a load point search (BOT tab). Tape will stop at load point and LOAD pushbutton will illuminate.

Note

If the tape unit is tensioned with the load point reflective tab under the photosense head, Drive Ready condition is not set. (Drive Ready is a result of load point search being satisfied.) With the tape unit in this condition, pressing the LOAD pushbutton gates Load Point and On-Line status to the interface without a Ready status. However, ON-LINE and LOAD POINT will be indicated on the front panel. Ensure the load point reflective tab is not positioned under the photosense head when tape is tensioned. The tab should be before the photosense head or on the supply reel.

3-23. OPERATION.

3-24. The tape unit is designed for processor (computer) controlled operation. However, manual controls are provided to bring the unit to on-line status, to restart after a power failure, to position tape for addition of photosense tabs, and as a service aid during repair or checkout. The controls that the operator will normally use are located on the control panel.

Note

In multiple unit installations, do not power down more than one unit at a time. If power is removed from more than one unit, circuit loading may cause intermittent operation.

3-25. ON-LINE READ-ONLY OPERATION.

3-26. To operate the unit in read-only mode, proceed as follows:

- a. Remove write enable ring from supply reel.

- b. Install supply reel.

- c. Thread tape and place tape at load point.

- d. If unit is equipped with a density select option, press density selection.

- e. If unit is equipped with an address select option, press address pushbutton.

- f. Press ON-LINE pushbutton. Unit is now in ready status under processor control.

- g. To stop unit, press RESET.

- h. Press ON-LINE to place unit under control of processor.

- i. Press address select OFF pushbutton to remove unit from processor control without disturbing unit logic. To place unit under processor control again, press unit address select pushbutton.

3-27. ON-LINE WRITE-READ OPERATION.

3-28. To operate the unit in write-read mode, proceed as follows:

- a. Install write enable ring to supply reel.

- b. The rest of this procedure is identical to the read only operation. Refer to paragraph 3-26 (steps "b" through "i").

3-29. REWIND.

3-30. High-speed rewind can be initiated during any tape function by pressing RESET and then pressing REWIND. To stop rewind at any tape position, press RESET. To resume rewind, press REWIND. Fast rewind will continue until the load point tab is sensed and passed. Unit logic will automatically go into load point search and stop at load point.

3-31. RESTART AFTER POWER FAILURE.

3-32. After a power failure during a read, write, or read-after-write operation, the unit will be off-line. To resume interrupted function, proceed as follows:

- a. Open cover door.

- b. Verify that tape is on guides.

- c. Press LOAD.

- d. Close cover door.

- e. Press RESET.

- f. Press ON-LINE.

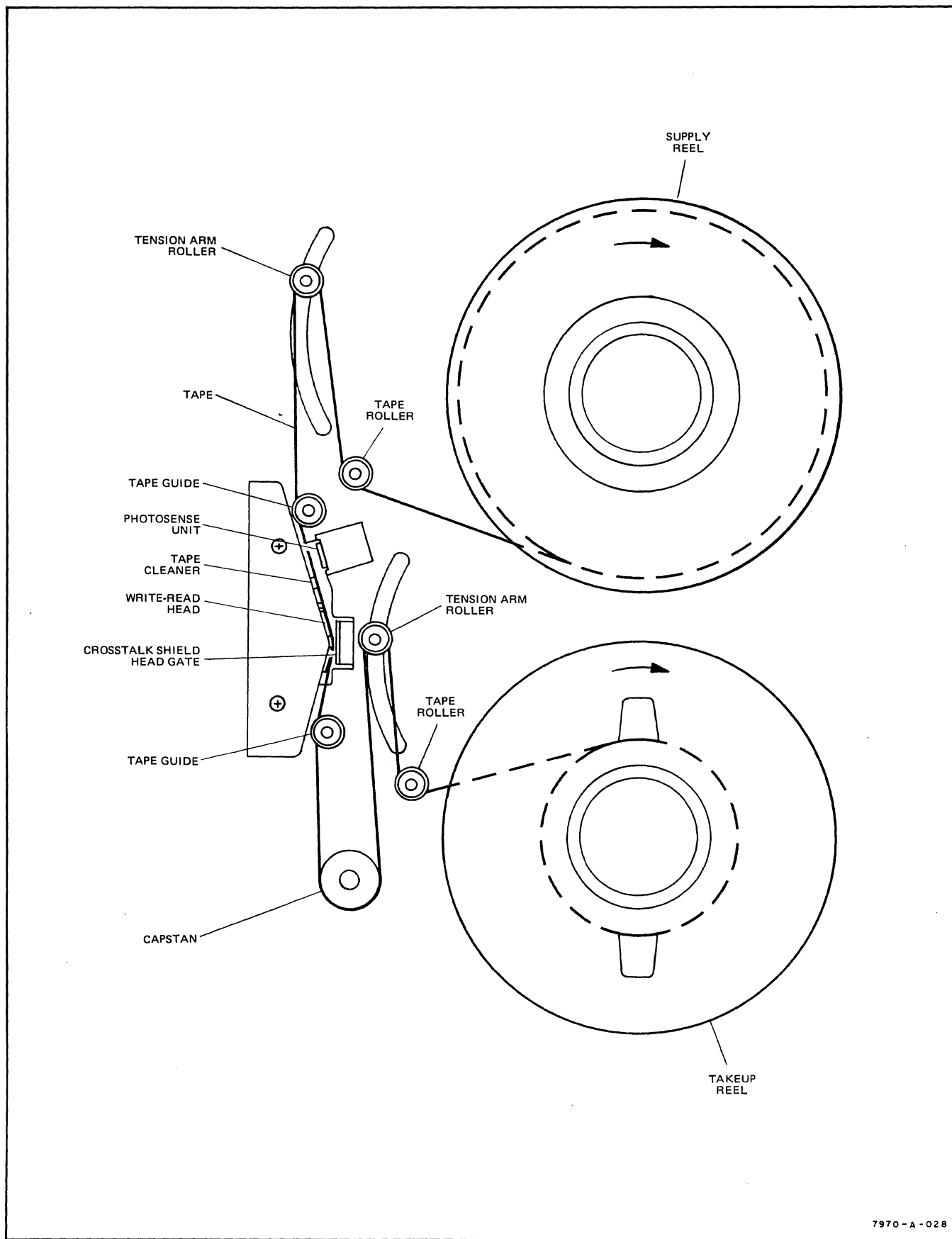

7970-A-028

Figure 3-3. Tape Threading

3-33. REV, FWD, and +160 CAPSTAN SERVO TOGGLE SWITCHES.

Note

These switches are for service only.

3-34. To use the REV (reverse), FWD (forward), and +160 (high-speed forward at 160 ips) switches proceed as follows:

- a. Open cover door.
- b. Install tape supply reel.
- c. Thread tape.
- d. Set power switch to ON.
- e. Tension tape.
- f. Release transport latch.
- g. Close cover door and swing transport open.
- h. Operate service switches as desired.
- i. Leave all switches in OFF position before assuming normal operation.

3-35. CHECKOUT PROCEDURES.

3-36. The following performance checks may be used for incoming inspection or as an overall performance check-out after making adjustments or repair. Off-line performance checks should be performed as soon as the unit is installed to determine that the unit is in proper working order. No test equipment is required. On-line performance checks will ensure that the unit will respond to external commands. On-line performance checks will depend upon unit application. On-line refers to a unit that is connected to a controlling device such as a computer, plotter, or key-to-tape system. An on-line unit is addressable by the controlling device and requires a minimum amount of operator intervention.

3-37. OFF-LINE PERFORMANCE CHECKS.

3-38. Off-line performance checks consist of a visual mechanical check and a motion control checkout procedure. The mechanical check is performed prior to applying power to the unit. The motion control checkout procedures require operating power and must be performed by a qualified system level maintenance technician or a Hewlett-Packard Service Representative.

3-39. MECHANICAL CHECK.

3-40. Perform mechanical check as follows:

- a. Open and close cover door and verify that detents hold firmly.

- b. Swing cover door open and verify that hinges are free and that the door stop bracket prevents the cover door opening more than approximately 105 degrees.

- c. Press upper control panel pushbuttons and verify that the RESET, REWIND, ON-LINE, and LOAD pushbuttons press freely and bottom.

- d. Press density select and address select pushbuttons and verify that the mechanical interlocks are working properly.

- e. Release the transport latch and swing the transport out.

- f. Verify that all cable connectors are securely seated.

- g. Verify that all motion and data cards are securely seated.

- h. Verify that there is unobstructed airflow for instrument cooling.

- i. Slowly open and close transport and note that wire harnesses, wire cable, and ribbon cables fold properly.

- j. Verify that select jumper is connected to the proper pin. The proper pin connection is as follows:

- (1) Tape units equipped with unit (address) select option: connect select jumper to pin labeled OFF.

- (2) Tape units not equipped with unit (address) select option: connect select jumper to pin labeled 0 (or any pin desired, 0 to 3).

- k. Close and latch transport.

- l. Open/close cover door and note that it rests snugly against rubber seal.

3-41. MOTION CONTROL CHECKOUT PROCEDURE.

3-42. Perform the motion control checkout procedure as follows:

- a. Check 115-230 Vac slide switch for proper line voltage, and connect ac power.

- b. Verify that manual control switches located on the capstan servo PCA are in the OFF position (switch levers down).

- c. Set power switch to ON. The following pushbutton indicators will illuminate: RESET, unit select, and density select.

- d. Remove write enable ring and place a reel of tape on the supply hub (with BOT and EOT tabs attached). Reel should be seated firmly to the hub when the quick disconnect hub is latched.

e. Verify that empty reel on the takeup hub is properly seated.

f. Thread tape and verify that tape is inserted between tape guide flanges.

g. Press LOAD pushbutton and hold. Tape will move until tape tension arms are centered and proper tape tension is established.

h. Release LOAD pushbutton. Motion control logic initiates a load point search. Tape will move forward at 20 ips and will stop at load point. LOAD indicator will illuminate.

i. Close cover door.

j. Press density select pushbuttons, one at a time, and note indicators. Pushbutton selected will illuminate and go dark when the next pushbutton is selected and illuminates.

k. Press address select pushbuttons: 0, 1, 2, 3, and OFF and note indicators. Leave one address selected. The 0 pushbutton indicator will illuminate and go dark when 1 pushbutton is pressed, etc. Note that all address select pushbuttons are dark, except OFF, when OFF pushbutton is pressed.

l. Press ON-LINE pushbutton and release. ON-LINE pushbutton indicator will illuminate; The tape unit is now ready for processor control. The on-line condition negates the REWIND and LOAD pushbutton circuits. A substantial number of logic functions are initiated by the ON-LINE pushbutton. However, the following logic functions must occur before the unit is gated to on-line status.

- (1) The On-Line signal is and-gated with a Load Complete signal to generate a Ready signal (RDY).
- (2) The RDY signal is "and" gated with a Select-On Line-Address (SOLA) signal to generate a Status Ready (SR) signal for the processor. (SR indicates that tape unit is selected, is on-line, the initial loading sequence is complete, and the tape is not rewinding.)

m. Press REWIND pushbutton; press LOAD pushbutton and observe transport response. No response should be observed.

n. Press RESET pushbutton. ON-LINE indicator will go dark and RESET pushbutton will illuminate. Unit is now in off-line status. Manual controls are operative.

o. Check REWIND and capstan manual controls as follows:

- (1) Open cover door and release transport latch.
- (2) Close cover door.
- (3) Swing transport open.
- (4) Set capstan servo FWD switch to ON (up). Observe that tape moves in forward direction.

(5) Set FWD switch to OFF. Observe that motion stops.

(6) Set capstan servo +160 (ips) switch to ON (up). Observe that tape winds onto takeup reel at high speed. Allow approximately 100 feet of tape to wind on takeup reel.

(7) Set +160 switch to OFF. Observe that tape motion stops.

(8) Set capstan servo REV switch to ON (up). Observe that tape moves in reverse direction. Set REV switch to OFF. Observe that tape movement stops.

p. Press REWIND pushbutton (control panel). Observe that tape winds onto supply reel at high speed.

q. Press RESET pushbutton. Observe that tape movement stops. REWIND pushbutton will go off and RESET indicator will illuminate.

r. Press REWIND pushbutton. Observe that transport goes into fast rewind. RESET indicator is off and REWIND indicator is illuminated. The tape will rewind past the load point tab, stop, and move forward at 20 ips to the load point. At this point, tape will stop and the LOAD indicator will illuminate.

s. Hold REWIND pushbutton down until EOT tab passes photosense unit and then release pushbutton. Observe that tape winds off the takeup reel. Observe that REWIND pushbutton goes dark. The following pushbutton indicators will illuminate: RESET, density select, and address select.

t. Remove supply reel and install write enable ring.

u. Install supply reel. Observe that WRITE ENABLE indicator is illuminated.

v. Return unit to original configuration.

3-43. ON-LINE PERFORMANCE CHECKS.

3-44. On-line performance checks consist of exercising the unit using external commands. The on-line performance checks must be performed by a qualified technician. The controlling device must be able to exercise the unit transport circuits, the read data circuits, and the write data circuits (units equipped with write data modules). Tape units interfaced to a computer may be exercised with the controller diagnostic. If a controlling device is not available, on-line performance checks may be simulated using the test board accessories. (HP 13191A Control and Status Test Board Accessory, HP 13192A Write Test Board Accessory, and HP 13193A Read Test Board Accessory.) The following procedures describe the use of the test accessories to simulate on-line performance checks.

3-45. TRANSPORT PERFORMANCE CHECKS (SIMULATED ON-LINE).

3-46. The following procedures describe transport performance checks using the HP 13191A Control and Status Test Board Accessory to simulate on-line conditions.

a. Check the 115/230 Vac slide switch for proper line voltage and connect power.

b. Verify that manual control switches on the capstan servo PCA are in the off position (switch levers down).

c. Ensure that power switch is in the OFF position. Install the control and status test board accessory as described in the manual supplement for the test board accessory.

d. Set all switches of the test board accessory in the down position.

e. Load the transport with a reel of scratch tape equipped with BOT and EOT tabs. The tabs should be positioned to allow at least 3 minutes of high-speed operation between tabs.

f. Place the unit on-line by pressing the tape unit ON-LINE pushbutton switch. The LOAD and ON-LINE indicators of the tape unit will illuminate, the SL, SLP, and SR indicators of the test board accessory will illuminate. If the reel of tape installed was not equipped with a write enable ring, the SFP indicator will illuminate indicating a file protect status.

g. Set the CH (high-speed) switch of the test board in the up position.

h. Set the CRW (rewind) switch of the test board in the center (off) position.

i. Set the CF (forward) switch of the test board in the up position. Tape moves forward at 160 ips (high-speed forward). Tape stops at EOT tab and SET indicator of test board illuminates.

j. Set the CF switch in the down position, press the RESET pushbutton of the tape unit, and rewind the tape by pressing the REWIND pushbutton. Tape will rewind past BOT tab, stop, move forward to search load point (BOT tab), and stop at the BOT tab. At this point, the LOAD indicator will illuminate.

k. Place the tape unit back on-line by pressing the ON-LINE pushbutton. The ON-LINE indicator will illuminate.

l. Set the CH (high-speed) switch in the down position.

m. Set the CF (forward) switch in the up position. Tape moves forward at synchronous speed. Tape stops at EOT tab and SET indicator of test board illuminates.

n. Repeat steps "j" and "k."

o. Set the PROG-MAN switch in the PROG position (up).

p. Set the CRW (rewind) switch in the down position.

q. Set the CF (forward) switch in the up position. Tape starts and stops at synchronous speed until EOT tab is detected. SET indicator of test board illuminates and tape rewinds to load point.

r. Set all switches of the test board in the down position, press the RESET pushbutton of the tape unit and press the REWIND pushbutton to remove the scratch tape. Set the tape unit power switch in the OFF position.

3-47. READ DATA PERFORMANCE CHECK (SIMULATED ON-LINE).

3-48. The following procedures describe read data performance checks using the HP 13193A Read Test Board Accessory to simulate on-line conditions. The transport performance checks must be performed prior to performing these procedures.

a. Ensure that tape unit power switch is in the OFF position. Install the read test board accessory as described in the manual supplement for the test board accessory.

b. Ensure that all switches of the control and status test board accessory have been set in the down position.

c. Set the RD BL switch of the read test board to the off position (right).

d. Select desired parity (odd or even) by placing the read test board parity select switch in the appropriate position.

e. Determine the synchronous speed of the tape unit and place the HI-LO switch (speed range) of the read test board in the appropriate position (HI position for 20.1 to 45 ips units or LO position for 10 to 20 ips units).

f. Load the tape unit with a reel of prerecorded tape.

g. Place the unit on-line by pressing the ON-LINE pushbutton.

h. Set the RD BL switch of the read test board to RD BL (left) position. Tape moves forward at synchronous speed, stopping and starting between data blocks.

Note

Ensure that the 10 clock period delay adjustment has been made as described in paragraph 36, steps "e" and "h" of read test board manual supplement.

i. Set the ERROR STOP-NORM switch of the read test board to the STOP position. If the prerecorded tape contains errors, the tape unit will stop when an error is detected and the error or errors will be displayed by the read test board.

j. Set the ERROR STOP-NORM switch of the read test board in the NORM position. The tape will continue forward at synchronous speed stopping and starting between data blocks, until EOT tab is detected or RD BL switch is returned to the off position (right).

k. Press the tape unit RESET pushbutton to place the unit off-line and rewind the tape by pressing the RE-WIND pushbutton.

l. Remove the pre-written tape and remove power to the unit by placing the power switch in the OFF position.

3-49. WRITE DATA PERFORMANCE CHECK (SIMULATED ON-LINE).

3-50. The following procedures describe write data performance checks using the HP 13192A Write Test Board Accessory to simulate on-line conditions. The transport performance and read data performance checks must be performed prior to performing the write data performance checks.

a. Ensure that tape unit power switch is in the OFF position. Install the write test board accessory as described in the write test board accessory manual supplement.

b. Set all switches of the control and status test board accessory in the down position.

c. Set the RD BL switch of the read test board accessory to the OFF (right) position.

d. Select the desired parity (odd or even) by placing the parity select switches of the read and write test board accessories in the appropriate positions.

e. Determine synchronous speed of the tape unit and place the HI-LO switch (speed range) of the read test board accessory in the appropriate position to (HI position for 20.1 to 45 ips or LO position for 10 to 20 ips).

f. Load the unit with a reel of blank tape equipped with a write enable ring.

g. Ensure that WCF lead (P1) from the write test board is connected to the CF terminal of the control and status test board.

h. Place the unit on-line by pressing the ON-LINE pushbutton.

i. Set the ERROR STOP-NORM switch of the read test board in the NORM position.

j. Set the XTALK-BLOCK switch of the write test board in the BLOCK position

k. Set the WSW switch of the control and status test board in the up position.

l. Rotate the PCF control fully counterclockwise.

m. Adjust the clock rate of the write test board as described in the write test board manual supplement.

n. Set the RD BL switch of the read test board accessory to the RD BL position (left). Tape moves forward at synchronous speed.

o. Set the CF switch of the control and status test board in the up position.

p. Rotate PCF control of the control and status test board clockwise until start-stop action begins.

q. Observe the read test board indicators for error indications.

r. Rotate PCF control of the control and status test board fully counterclockwise and set the CF switch in the down position.

s. Set the RD BL switch of the read test board in the off position (right).

t. Set the WSW switch of the control and status test board in the down position.

u. Press the tape unit RESET pushbutton to place the unit off-line and rewind the tape by pressing the RE-WIND pushbutton.

3-51. OPERATOR MAINTENANCE.

3-52. Operator maintenance is confined to simple preventive maintenance procedures. Periodic maintenance and mechanical/electrical checkout procedures should be performed on a scheduled basis by a qualified technician. These procedures require test equipment normally available in a well-equipped test facility. If a system-level maintenance technician is not available, a Hewlett-Packard Service Representative should be contacted.

3-53. The preventive maintenance schedule is contained in table 3-2. The operator should only perform the 8-hour interval procedure as indicated. However, the operator should keep an hourly operating log so that the equipment will be checked, adjusted, and serviced at the indicated intervals.

3-54. The preventive maintenance schedule listed in table 3-3 describes the routines to be performed on a scheduled basis by a maintenance technician.

Table 3-2. Operator Preventive Maintenance Schedule

MAINTENANCE INTERVAL (HOURS)	MAINTENANCE ROUTINE
8	<ol style="list-style-type: none"> 1. Clean tape path components. 2. Visually inspect tape drive components.
1000	<ol style="list-style-type: none"> 1. Perform 8-hour routine. 2. Notify maintenance technician that 1000-hour maintenance routine is due.
2000	<ol style="list-style-type: none"> 1. Perform 8-hour routine. 2. Notify maintenance technician that 2000-hour maintenance routine is due.
4000	<ol style="list-style-type: none"> 1. Perform 8-hour routine. 2. Notify maintenance technician that 4000-hour maintenance routine is due.

Table 3-3. Service Preventive Maintenance Schedule

MAINTENANCE INTERVAL (HOURS)	MAINTENANCE ROUTINE
1000	<ol style="list-style-type: none"> 1. Clean tape transport. 2. Check reel holddown assembly. (Refer to part 2.) 3. Check EOT/BOT photosense head assembly. (Refer to part 2.) 4. Check write enable assembly. (Refer to part 2.) 5. Check power supply. (Refer to part 2.) <ol style="list-style-type: none"> a. Regulated voltages. b. 20/40 volt switch circuit. 6. Check capstan servo. (Refer to part 2.) <ol style="list-style-type: none"> a. Off-set adjustments. b. Tape speed. c. Start/stop ramp. 7. Check reel servo adjustments. (Refer to part 2.) 8. Check all tape motion functions. (Refer to part 2.) 9. Check tension arm photosense masks. (Refer to part 2.) 10. Check data electronics. (Refer to parts 3, 4 or 5.) <ol style="list-style-type: none"> a. Read preamplifier gain. b. Read skews. c. Read character gate. d. Write skews.
2000	<ol style="list-style-type: none"> 1. Perform 1000-hour routine. 2. Replace BOT/EOT photosense lamp. 3. Replace tension arm photosense lamp.
4000	<ol style="list-style-type: none"> 1. Perform 2000-hour routine. 2. Replace capstan pulley. 3. Replace tension arm springs and pins. 4. Replace reel motor brushes. 5. Replace capstan motor brushes.

3-55. Perform the 8-hour procedure as follows:

a. Run tape and visually check for tape scraping on reel flanges, tape guide flanges, or uneven travel on the capstan. If tape reel flange scraping is observed, verify that the reel is properly seated on the hub. Notify maintenance technician if condition persists.

b. Remove tape reels.

c. Set power switch to OFF.

d. Push head gate inward and hold to clean write/read heads.

Note

Clean tape path components with cotton-tipped applicators (part number 8520-0023, or equivalent) and lint-free wipers moistened with one of the following cleaners:

1. Head Cleaner (HP 8500-1251).
2. Genesolve D (Allied Chemical).
3. Freon TF (Dupont).

Use cleaners sparingly and avoid contaminating bearings. Be alert to any mechanical malfunction to prevent possible damage to recorded data.

e. Clean heads and check for scratches.

f. Release head gate to operating position.

g. Clean tape cleaner.

h. Clean photosense head.

i. Clean stationary guides and rollers. Verify that moving rollers are revolving freely.

j. Clean capstan. (Use solvents on rubber capstan sparingly.)

k. Clean transport area.

Note

Cover door is fitted with plexiglas. Brush away any heavy residue with a soft-bristle brush and clean gently with a wiper and commercial glass cleaner.

l. Set power switch to ON.

m. Install tape reels.

n. Thread tape.

o. Tension tape and position at load point.

p. Make density selection.

q. Make address selection.

r. Place unit on-line.

3-56. FUSE REPLACEMENT.

3-57. AC LINE FUSES.

3-58. The two ac line fuses are located on the interior, rear panel. For 115 Vac operation, a 4 ATT fuse is required (TT: super time lag). For 230 Vac operation, a 2 ATT fuse is required.

3-59. SECONDARY VOLTAGE FUSES.

3-60. The secondary voltage fuses are mounted to the power supply PCA. Fuse values are placarded at or near the fuse clip. Place a small screwdriver under the metal end of the fuse and pry outward to remove fuse. Use caution not to damage fuse clip.

Table 3-4. Reference Designations and Abbreviations

REFERENCE DESIGNATIONS		
<p>A = assembly B = motor, synchro BT = battery C = capacitor CB = circuit breaker CR = diode DL = delay line DS = indicator E = Misc electrical parts F = fuse FL = filter J = receptacle connector</p>	<p>K = relay L = inductor M = meter P = plug connector Q = semiconductor device other than diode or integrated circuit R = resistor RT = thermistor S = switch T = transformer</p>	<p>TB = terminal board TP = test point U = integrated circuit, non-repairable assembly V = vacuum tube, photocell, etc. VR = voltage regulator W = jumper wire X = socket Y = crystal Z = tuned cavity, network</p>
ABBREVIATIONS		
<p>A = amperes ac = alternating current Ag = silver Al = aluminum ar = as required adj = adjust assy = assembly</p> <p>b = base bp = bandpass bpi = bits per inch blk = black blu = blue brn = brown brs = brass Btu = British thermal unit Be Cu = beryllium copper</p> <p>cp = characters per inch coll = collector cw = clockwise ccw = counterclockwise cer = ceramic com = common crt = cathode-ray tube CTL = complementary-transistor logic cath = cathode Cd pl = cadmium plate comp = composition conn = connector compl = complete</p> <p>dc = direct current dr = drive DTL = diode-transistor logic depc = deposited carbon dpdt = double-pole, double-throw dpst = double-pole, single-throw</p> <p>em = emitter ECL = emitter-coupled logic ext = external encap = encapsulated elctlt = electrolytic</p> <p>F = farads FF = flip-flop flh = flat head flm = film fxd = fixed filh = fillister head</p> <p>G = giga (10⁹) Ge = germanium gl = glass gnd = ground(ed)</p>	<p>gra = gray grn = green</p> <p>H = henries Hg = mercury hr = hour(s) Hz = hertz hdw = hardware hex = hexagon, hexagonal</p> <p>ID = inside diameter IF = intermediate frequency in. = inch, inches I/O = input/output int = internal incl = include(s) insul = insulation, insulated impgrg = impregnated incand = incandescent ips = inches per second</p> <p>k = kilo (10³), kilohm</p> <p>lp = low pass</p> <p>m = milli (10⁻³) M = mega (10⁶), megohm My = Mylar mfr = manufacturer mom = momentary mtg = mounting misc = miscellaneous met. ox. = metal oxide mintr = miniature</p> <p>n = nano (10⁻⁹) nc = normally closed or no connection Ne = neon no. = number n.o. = normally open np = nickel plated NPN = negative-positive-negative NPO = negative-positive zero (zero temperature coefficient) NSR = not separately replaceable NRFR = not recommended for field replacement</p> <p>OD = outside diameter OBD = order by description orn = orange ovh = oval head oxd = oxide</p> <p>p = pico (10⁻¹²) PC = printed circuit</p>	<p>PCA = printed-circuit assembly PWB = printed-wiring board phh = phillips head pk = peak p-p = peak-to-peak pt = point prv = peak inverse voltage PNP = positive-negative-positive pwv = peak working voltage porc = porcelain posn = position(s) pozi = pozidrive</p> <p>rf = radio frequency rdh = round head rms = root-mean-square rwv = reverse working voltage rect = rectifier r/min = revolutions per minute RTL = resistor-transistor logic</p> <p>s = second SB, TT = slow blow Se = selenium Si = silicon scr = silicon controlled rectifier sst = stainless steel stl = steel spcl = special spdt = single-pole, double-throw spst = single-pole, single-throw</p> <p>Ta = tantalum td = time delay Ti = titanium tgl = toggle thd = thread tol = tolerance TTL = transistor transistor logic</p> <p>U(μ) = micro (10⁻⁶)</p> <p>V = volt(s) var = variable vio = violet Vdcw = direct current working volts</p> <p>W = watts ww = wirewound wht = white WIV = working inverse voltage</p> <p>yel = yellow</p>