

IBM

Systems Reference Library

IBM 2740 Communication Terminal Models 1 and 2 Component Description

This publication describes the application areas, principles of operation, line-control signals, and special features of the IBM 2740 Communication Terminal Models 1 and 2. The communication facilities and data sets that can be used with this Tele-processing terminal are also discussed. Included is a glossary of communication terms used in this publication, and the timing formulas necessary to calculate the data-handling capability of the terminal.

Use this guide to determine what available publications will best fulfill your individual requirements

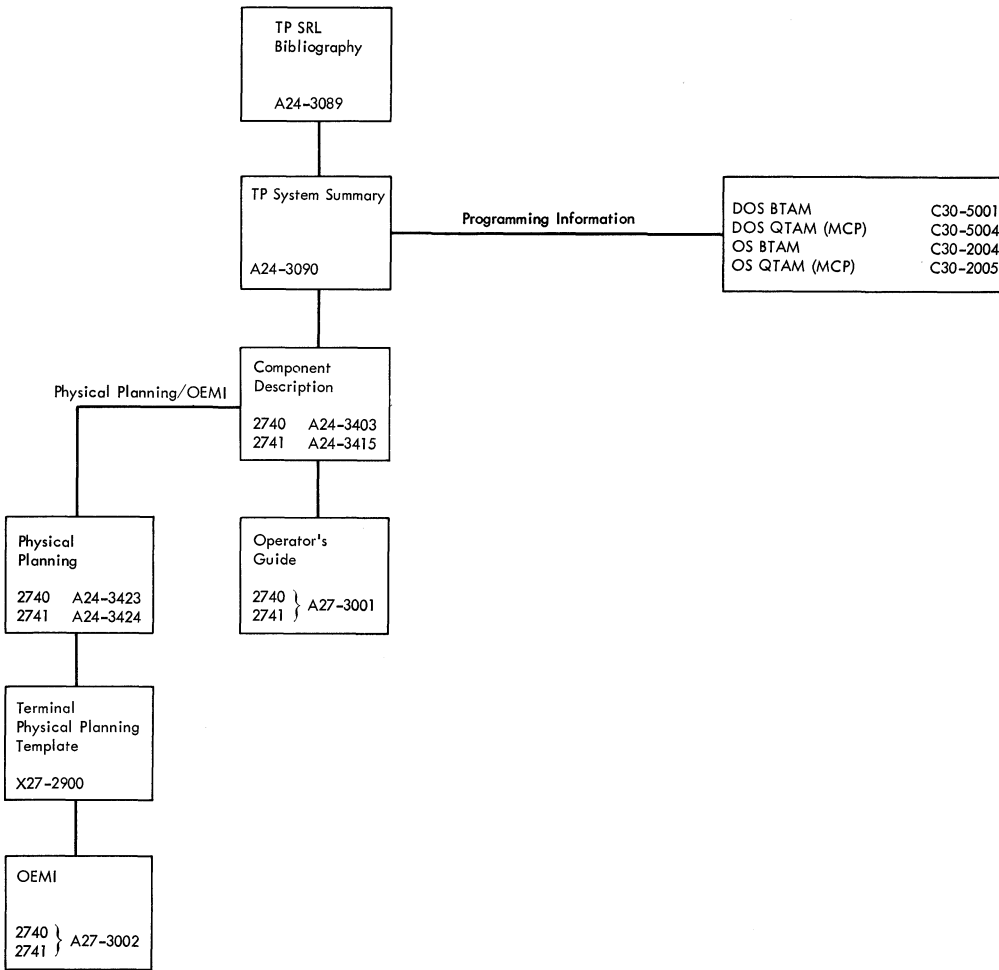

Fourth Edition (August, 1968)

This manual, Form A24-3403-3, is a major revision of, and obsoletes the previous edition, A24-3403-2. Significant changes have been made throughout the manual; therefore, it should be reviewed in its entirety.

Operating procedures for the IBM 2740 Models 1 and 2, and the IBM 2741, are described in the SRL publication IBM 2740/2741 Communications Terminal--Operator's Guide, Form A27-3001. For information on other IBM Tele-processing products, see IBM Tele-processing Bibliography, Form A24-3089.

Significant changes or additions to the specifications contained in this publication are continually being made. When using this publication in connection with the operation of IBM equipment, check the latest SRL Newsletter for revisions or contact the local IBM branch office.

This manual has been prepared by the IBM Systems Development Division, Product Publications, Dept. 860, P. O. Box 12275, Research Triangle Park, N. C. 27709. Address comments concerning the manual to this address.

IBM 2740 COMMUNICATION TERMINAL, MODEL 1	1	IBM 2740 COMMUNICATION TERMINAL, MODEL 2	27
Types of Operation	2	Introduction	27
Applications	3	Communication Facilities	28
Communication Facilities	3	Data Sets	28
Data Sets	4	Modes of Operation	28
Line-Control Signals	4	Local Mode	28
TRANSMISSION CONTROLS AND INDICATORS, MODEL 1	7	Communicate	29
Local/Communicate Key	7	Codes, Keyboard Arrangements, and Print Elements	29
Standby (S) Light	7	Transmission Controls and Indicators, Model 2	29
Transmit (T) Light	7	On/Off Power Switch	29
Receive (R) Light	7	Keys	29
Bid Key and Light	7	Switches	30
Restart (RST) Key and Light (Checking Special Feature)	8	Indicator Lights	31
Dial-Disconnect (Disc) Key and Dial-Connect Light (Dial- Up Adapter Special Feature)	8	Without Buffered Receive and Without Record Checking Special Features Installed	33
EOB (End-of-Block) Key (Checking Special Feature)	9	With Buffered Receive and Without Record Checking Special Features Installed	33
Automatic EOB (Prerequisite, Checking Feature)	9	With Record Checking and Without Buffered Receive Special Features Installed	33
EOT (End-of-Transmission) Key	10	With Record Checking and With Buffered Receive Special Features Installed	34
Transmit-Control Switch (MTC, Off) Transmit Control Special Feature	10	PRINCIPLES OF OPERATION, MODEL 2	35
Test Switch	10	Local Mode	35
PRINCIPLES OF OPERATION, 2740 MODEL 1	11	Communicate Mode	35
Point-to-Point Operation (Terminal-to-Terminal)	11	Station Control (Multiplexer Addressing and Polling)	36
Broadcast Operation	12	Polling	36
Dial-Up Operation	13	Addressing	36
Dial-Up Operation (with checking)	13	SPECIAL FEATURES, MODEL 2	39
Point-to-Point Operation--Multiplexer and Terminal	14	Buffer Expansion	39
Point-to-Point Operation--Multiplexer and Terminal with Dial-Up Feature Installed	15	Record Checking	39
Transmit Control--Multiplexer	16	Operation	39
Station Control--Multiplexer Addressing and Polling	16	Transmitting Terminal	39
SPECIAL FEATURES, MODEL 1	17	Receiving Terminal	39
Dial-Up Adapter	17	Buffered Receive	40
Transmit Control (Prerequisite, Dial-Up Adapter Feature)	17	Telegraph Line Adapter	40
Automatic Disconnect Feature (World Trade Only)	18	Speed Base--600 bps	40
Checking--Parity (VRC) and Block (LRC)	19	Header Control	40
Station Control (Multiplexer Addressing and Polling)	19	Edit	40
Automatic EOB (Prerequisite, Checking Feature)	21	Split Friction-Feed Platens	41
IBM 2760 Attachment	22	Document Insertion	41
IBM Line Adapter (Limited-Distance Type 1)	22	Ledger-Card Stock	43
IBM Line Adapter (Limited-Distance Type 2)	22	Operation	43
IBM Line Adapter (Leased Line)	22	Document Design	43
IBM Line Adapter (Shared Line)	22	Paper Guide, Tear Bar, and Roll Paper Holder	44
Pin-Feed Platens	22	Pin-Feed Platens	44
Paper Guide, Tear Bar, and Roll Paper Holder	23	IBM Line Adapter (Limited-Distance Type 1)	44
Timing Considerations, 2740 Model 1	23	IBM Line Adapter (Limited-Distance Type 2)	45
Time-Out Conditions	23	IBM Line Adapter (Leased Line)	45
Delay Conditions	23	IBM Line Adapter (Shared Line)	45
Typewriter Delay Conditions	23	Timing Considerations, Model 2	46
Data-Handling Capability, Model 1	24	Typewriter Delay Conditions	46
Terminal Transmission and Control Speed	24	IBM 2740 Model 2 Data-Handling Capability	46
Addressing Time	24	GLOSSARY	47
Polling Time (Negative Answer Back)	24	APPENDIX	49
Polling Time (Positive Answer Back)	24	INDEX	55
Checking Time (Receive Terminal, Positive Answer Back)	24		
Checking Time (Receive Terminal, Negative Answer Back)	24		
Checking Time (Transmit Terminal, Positive Answer Back)	24		
Checking Time (Transmit Terminal, Negative Answer Back)	24		

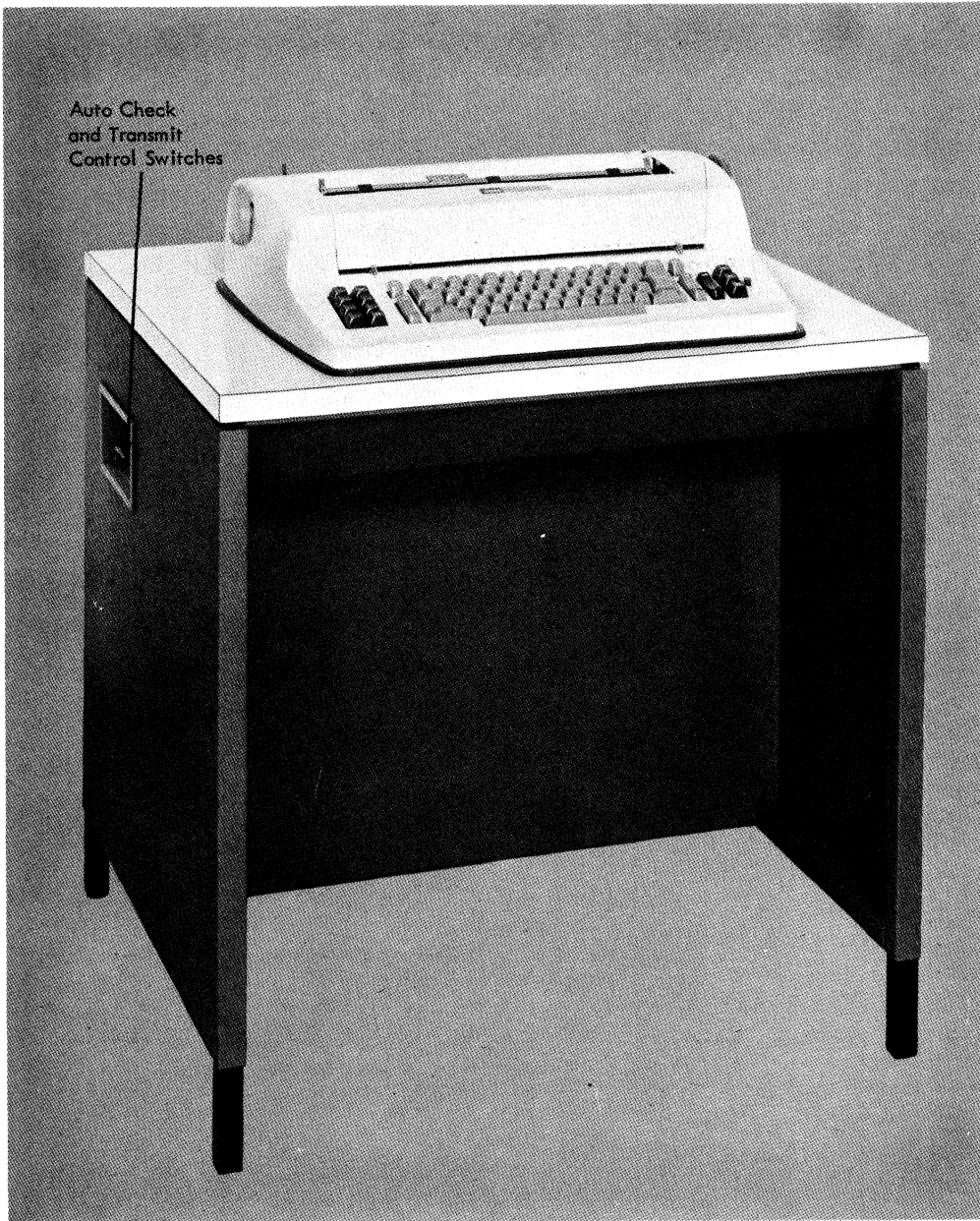

Figure 1. IBM 2740 Communication Terminal, Model 1

IBM 2740 COMMUNICATION TERMINAL, MODEL 1

The IBM 2740 Communication Terminal, Model 1 provides the capabilities of the standard Selectric typewriter combined with the added convenience and flexibility of a communications terminal. Thus, this dual-purpose unit can alternately function as:

- a document writer for correspondence or other normal secretarial applications (local mode);
- a data sending and receiving unit over communication lines (communicate mode), to another 2740 terminal (or terminals) or to a computer using an IBM 2701 Data Adapter Unit, an IBM 2702 or 2703 Transmission Control Unit, or an IBM 2712 Remote Multiplexer connected to a 2702 or 2703. Hereafter the above units will be referred to as multiplexers for ease of reading.

This Tele-processing terminal presents an opportunity for any company to provide quality correspondence copy at a customer's location to complete an inquiry-reply cycle on a same-day basis. This means that the 2740 can accomplish a significant time reduction in the normal cycle time involved in obtaining vendor information for executive-level decision making. With this terminal the total cycle time from the customer-initiated inquiry to receipt of the vendor reply is reduced from days (or weeks) to hours (or minutes).

The IBM 2740 Communication Terminal Model 1 (Figure 1) is a typing terminal that can be operated by a typist with a minimum of additional training.

The major advantages of the basic Selectric typewriter are retained, and added to these is the additional flexibility provided by the ability to communicate between remote locations. This typewriter offers the exclusive Selectric features of:

Stroke Storage. This permits faster keying action due to the reduction of interlocking action between the keys. Thus, when two keys are struck in rapid succession, the second character is stored until the first is printed.

*Perforated Tape and Transmission Code for Binary Coded Decimal environments, and Perforated Tape and Transmission Code for Extended Binary Coded Decimal environments (see code charts in Appendix.)

Typamatic Index Key. Pressing and releasing this key moves the paper up one line space. Pressing and holding this key down brings about the typamatic action, which causes the paper to rapidly line space until the key is released.

Interchangeable Print Elements. The print elements available for the 2740 Model 1 (PTTC/BCD*, and PTTC/EBCD* and Correspondence) are easily interchanged. This is accomplished by either pressing the spring levers or raising the handle (depending upon the element being used) and lifting it off the unit. The other element is positioned by snapping it into place.

NOTE: A choice of print elements (PTTC/BCD, PTTC/EBCD, or standard Selectric typewriter) is available at the time the 2740 Model 1 terminal is ordered.

Although the PTTC/BCD and PTTC/EBCD print elements are primarily used for terminal-to-computer applications (such as on-line computation or programming) they can also be used for terminal-to-terminal applications (such as inter/intra company communication or executive correspondence). However, the standard Selectric typewriter print element can also be used for terminal-to-computer applications (such as text handling) provided the users program is designed to accept the unique line code assignments for the associated graphics.

NOTE: The Correspondence code and the PTTC/BCD code (with their associated keyboard arrangements and print elements) are not System/360 Type 1 Program supported.

The graphics and associated line transmission bit values for the Correspondence code differ from the bit values of the PTTC/BCD and PTTC/EBCD codes. (See code charts and keyboards in Appendix). Although a choice of print elements is available, it is important that all interconnected terminals use the same type of print element: either all standard Selectric typewriter, all PTTC/BCD, or all PTTC/EBCD. Although the PTTC/BCD print element is manually interchangeable with the PTTC/EBCD print element (same line bit value assignments), the standard Selectric typewriter print element is not interchangeable with either of these print elements. In all cases, the keyboard interposers must match the associated print element to be used.

Compact Ribbon Cartridge. The ribbon cartridge provides a clean and efficient approach to ribbon changing. With this cartridge, ribbon changing consists of snapping one cartridge off and the new one on. The entire process is accomplished in seconds.

Maximum Keying Efficiency. The terminal can operate at speeds up to 14.8 characters-per-second (cps), however, the keying rate will vary depending upon the speed of the operator. The keyboard is designed to provide maximum keying efficiency and throughput by retaining the basic Selectric type-writer features combined with easily accessible communication controls (Figure 2).

Types of Operation

The IBM 2740 Communication Terminal Model 1 can be specified for any one of three types of operations: point-to-point, between two terminals or terminal and multiplexer; dial-up, between two terminals or terminal and multiplexer over a switched network; or station control, when two or more terminals and a multiplexer communicate over the same non-switched line and the multiplexer (transmission control unit) is the master station. The particular type of operation is specified when the terminal is ordered, and thus a customized terminal is installed for one of the following types of system operation.



Figure 2. 2740 Model 1 Keyboard (PTTC/BCD)

Point-to-Point. Point-to-point operation requires the use of leased or privately owned private line communication facilities. It is intended to operate between two points (terminal-to-terminal or terminal-to-multiplexer). For communication between terminals (no multiplexer) more than two points may be included. However, when more than two points are included, all stations can receive the transmitted message and this becomes a broadcast application. The basic 2740 is capable of either point-to-point (terminal-to-terminal or terminal-to-multiplexer), or broadcast operation.

Dial-Up. Dial-up operation allows the user to have access to common-carrier switched Telephone or Teletypewriter Exchange (TWX) networks. Any 2740 terminal connected to this network can call (or be called by) another similarly connected 2740 terminal (or multiplexer). However, the dial-up adapter special feature must be installed on each terminal.

Station Control. This operation uses private line facilities (non-switched) and provides for communication with 2740 terminals on a multipoint basis. All communications in this type of operation are centralized (controlled by the multiplexer) and individual station addressing or polling, as well as group or broadcast addressing, is permitted.

Applications

When operating in local mode, the performance of the 2740 Communication Terminal is similar to a typewriter. When assigned to communicate mode, each message character keyed at the sending terminal is printed at both the sending and receiving terminals. This data is transmitted over the communication lines attached to the terminals. Several of the many application areas for which the IBM 2740 is designed are:

Intracompany Communication. Internal communication between company departments can be expedited by using the 2740. A quality memorandum is provided at the receiving end, using the appropriate upper and lower case letters plus special symbols, as required. An identical monitor copy is also available at the sending end for filing. For example, this operation could be between a purchasing and receiving department, with the receiving terminal preparing a memorandum copy for departmental distribution, as well as a running log of all received messages for future reference.

Remote Inquiry and Reply with a Computer. Using this terminal, individuals having access to a CPU (Central Processing Unit) can accomplish inquiry and reply type operations without leaving their department area. For instance, an engineer using a 2740 can enter desired variables into a Fortran program (used for processing of scientific data) available in the CPU, and start the program running. When a program run is completed, a reply can be returned to the original terminal. This entire operation requires only minutes, and the engineer can stay close to his work area during this time. In addition, the engineer can interrogate the program during its run to determine if the problem is staying within preset limits.

Intercompany Correspondence. Customer orders and correspondence are available from key locations sooner, when using the 2740 terminal. As a sales aid and to expedite customer orders, a 2740 can be installed in the purchasing department of your major customers. Then, when an order is placed with your company, the customer merely dials your number and types out his order. This provides both you and your customer with a completed copy of the order. Confirmation of the order and availability of all ordered items is provided by reversing the procedure. Thus, the ordering and confirmation cycle time is reduced by a significant amount and customer service can be improved.

Executive Correspondence. Effective two-way communication is easily maintained between the executive offices and the sales or manufacturing locations by employing the 2740. All messages are transmitted directly to the individual's secretary (executive or middle-management level), thereby eliminating possible costly delays or security exposure if processed normally by a communication center or mail room. The message is handled only by the executives and their secretaries at the sending and receiving locations.

COMMUNICATIONS FACILITIES

The IBM 2740 Model 1 operates in half-duplex mode only over a:

- Common-carrier switched telephone network,
- Common-carrier switched 150 bits-per-second (bps) Teletypewriter Exchange (TWX) network.
- Common-carrier leased private line telephone service.

- Common-carrier leased private line telegraph service (Telephone Company 150 Baud Schedule 1006 channels),
- Western Union Class D (180 baud) channels,
- Western Union Class E channels, or
- Privately owned communication facilities or equivalent.

When the 2740 is used on common-carrier switched networks, common-carrier provided data sets must be used. IBM Line Adapters are available for use on common-carrier leased private line telephone channels, or privately owned communication networks. Commercially available data sets can also be used with private line facilities if they present the proper interface to the 2740.

Point-to-point data communication is possible on all these networks, however, multipoint communication is possible only on leased private line or privately owned networks.

Data Sets

The IBM 2740 Model 1 operates over communication facilities using the following data sets or their equivalent:

- Western Electric Data Set 103A1 or 103A2--for use in point-to-point dial-up connections.
- Western Electric Data Set 103F2--for use in multipoint or point-to-point leased private line telephone service.
- IBM Line Adapters (Limited Distance Type 1, Limited Distance Type 2, Leased Line, and Shared Line)--for use in multi-terminal or point-to-point operations on privately owned line connections or common-carrier leased private connections. Refer to "Special Features" in the 2740 Model 1 section for further information.
- An appropriate channel termination for use on Telephone Company 150 baud (Schedule 3A) channels.
- Western Union Data Loop Transceiver 1183-A for use on Western Union Class D (180 baud) channels.

LINE-CONTROL SIGNALS

In terminal operations with a multiplexer or other terminals, a control discipline is required on the

communication line. This discipline is called line control, and one of its functions is to prevent two or more stations from attempting to use the line simultaneously (line contention).

The line-control signals (EOA, EOT, EOB, Yes, No, SOA, and Inquiry) are represented in a shorthand form \textcircled{D} , \textcircled{C} , \textcircled{B} , \textcircled{Y} , \textcircled{N} , \textcircled{S} , and \textcircled{d} respectively. This form is used in programming, as well as in communications and line-control discussions. Also, the terms "response" and "answer" are used in a restricted manner. These terms and signals are defined in the following:

Answer. The negative, positive, or no answer at all to a check (VRC or LRC) following an EOB.

Response. The negative, positive, or no response at all to addressing or polling.

\textcircled{D} --EOA (Pound sign character). Signal indicates:

- the Bid key has been pressed and the transmission of text data is to follow. This pertains to point-to-point operation or broadcast operation without the station control feature installed.
- an end-of-address, with text data to follow. This is used in multiplexer operations with the station control feature installed. This signal starts the LRC counter at both the sending and receiving terminals. The EOA signal is not included in the following LRC check.
- positive response to a poll from the multiplexer.

\textcircled{C} --EOT. This signal indicates:

- an end-of-transmission, and resets the LRC counters at both sending and receiving terminals.

\textcircled{B} --EOB. This signal indicates the end-of-a-unit-block of text. This is used when the checking feature is installed and is followed by the LRC character. This provides an LRC check comparison at the receiving terminal with the EOB character included in the check.

\textcircled{Y} --Positive Response, Yes (Period character). When this is received, it indicates:

- a positive response to an address.
- a positive answer to an EOB/LRC sequence when the checking feature is installed.

\textcircled{N} --Negative Response, No (Hyphen character). When this is received, it indicates:

- a negative response to an address.
- a negative response to a poll.
- a negative answer to an EOB/LRC sequence when the checking feature is installed. Either the hyphen or underscore character is printed as an indication of this condition (a different character is printed on IBM World Trade machines).

Ⓢ--SOA (Comma character). This is used to indicate a start-of-address condition, and is used when the station control feature is installed.

ⓓ--Positive Answer, Inquiry (Pound sign character). This signal is used in a multiplexer operation as a positive answer to an EOB/LRC sequence from the terminal (Figures 11 and 15). At this time, the terminal switches to a receive status. The character associated with this signal is not printed.



These controls and indicators are located directly adjacent to the left and right of the typing keyboard, as shown in Figure 2. They provide additional controls required for operating in communicate mode. Certain keys are associated with special features (as indicated) and are provided only when that feature is installed.

Local/Communicate Key

Press the Local, bottom portion of this two-position key (Figure 3), for local mode (normal typing). If your terminal is addressed to receive a message while in this mode, an alarm sounds automatically. If the alarm sounds, press the Com (Communicate) portion of the Local/Communicate key to receive the incoming message from the calling terminal or multiplexer.

Pressing the Com (Communicate) portion of this key places the terminal in communicate mode and the terminal can alternately transmit and receive from the communication line. However, the terminal is switched to a receive status only when signaled to do so by another terminal or computer.

Standby (S) Light

This light (Figure 3) is on when your terminal is in the communicate mode, in a ready status, and neither transmitting nor receiving (standby status). The typewriter motor is not running when the terminal is in this status. If the Bid key is operated, or the terminal receives a signal to receive, the terminal automatically shifts to either transmit or receive status and the typewriter motor is automatically turned on. When the terminal changes status, the Standby light is automatically turned off, and either the Transmit or Receive light turns on.

Transmit (T) Light

This light (Figure 3) is on during the time one can transmit information from the keyboard to the communications line and consequently to other terminals or a multiplexer. During this time the keyboard is unlocked and the terminal is controlling the communications line. This light also turns on when the terminal transmits the answerback to an EOB/LRC sequence when the Checking special feature is installed.

Receive (R) Light

This light (Figure 3) is on when your terminal is ready to receive a character from another terminal on the line, or from a multiplexer in the communications system. During this time your terminal can receive characters only from the terminal or multiplexer which initiated the call, and your keyboard is locked. When the checking feature is installed, this light also turns on while the terminal is awaiting an answerback to an EOB/LRC sequence.

Bid Key and Light

Point-To-Point Operation

Press this key to obtain the line to transmit a message (Figure 3). The Bid key can be operated only when your terminal is in a standby status (Standby light on). Operating this key places your terminal in transmit status (Transmit light on), turns the typewriter motor on, and causes a signal to be transmitted to the other terminal on the line. The other terminal recognizes this signal and automatically shifts from standby status to receive status. If a terminal is without paper, without data set status, or operating in local mode, it does not shift to receive status, but does sound an alarm alerting the operator that corrective action is required. The Bid light (located to the right of the Bid key) is not operative in a terminal-to-terminal type of operation.

Broadcast Operation

When operating in broadcast mode (more than one other terminal on the same communications channel) press the Bid key to obtain the communications line to transmit a message. The Bid key can be operated only when your terminal is in standby status and the Bid light is on. The Bid light on indicates that the terminals in the broadcast network are in contention for the line; that is, no other terminal in the broadcast network is on the line and sending a message. Operating the Bid key shifts your terminal to transmit status (Transmit light on, Standby light off), turns the typewriter motor on, and turns the Bid light off (see Broadcast Operation under "Principles of Operation, 2740 Model 1;")

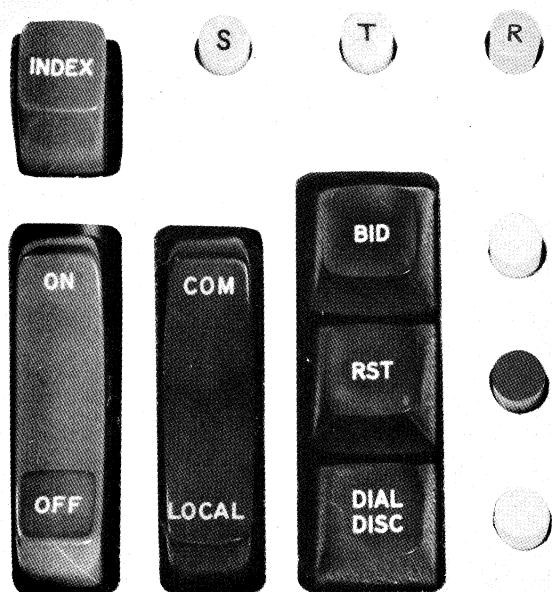

Figure 3. IBM 2740 Model 1 Transmission Controls (Right Side of Keyboard)

Check-Loop Test

The Bid key is also used to test a portion of the electronic circuitry of the terminal (see "Test Procedures" section in the IBM 2740/2741 Communication Terminal--Operator's Guide, Form A27-3001). Set the local/communicate switch to the local position to perform the test. While holding the Bid key down, a single operation of any one of the character keys on the keyboard (except Shift key) causes that character to print repeatedly. This indicates that the electronic circuitry associated with the printing of the character is functioning properly. Releasing the Bid key stops the repeat printing.

Station Control (Special Feature)

When the Station Control special feature is installed, operating the Bid key sets up a circuit to notify the multiplexer of a message to be transmitted when the multiplexer polls the terminal. The Bid light turns on to indicate a request to transmit the next time your terminal is polled (called) by the multiplexer. When your terminal is polled and shifts to transmit status, the Bid light turns off, the Transmit light turns on, and an alarm sounds to notify you that transmission can begin from your terminal (see Station Control under Special Features, Model 1).

Restart (RST) Key and Light (Checking Special Feature)

The Restart light is located to the right of the Restart key (Figure 3). When in transmit status, the Restart light at your terminal turns on when you perform a checking sequence (press EOB key) and remains on if the message you transmitted was received incorrectly at the receiving terminal. When in transmit status, pressing the Restart key turns the light off, unlocks the keyboard, and allows message transmission to continue, or the error message to be retransmitted. When in receive status, the Restart light turns on as soon as an error is detected and turns off automatically when your terminal sends a negative answer to the transmitting terminal.

Dial-Disconnect (Disc) Key and Dial-Connect Light (Dial-Up Adapter Special Feature)

Use this key to disconnect the line in a dial-up line connection (Figure 3). If in transmit status, the EOT key must be operated before operating this key.

Pressing this key, following the operation of the EOT key, releases both terminals from the communications line (provided both data sets have the Automatic Disconnect feature installed). Otherwise, this key must be operated at each terminal following the operation of the EOT key.

The Dial-Connect light on indicates that the terminal originating the dial connection is connected to a remote terminal and is in standby status (communicate mode). The Dial-Connect light at the remote terminal also turns on when the connection is established and turns off when the terminal shifts to transmit or receive status. When the originating terminal goes into the transmit or receive status, this light turns off and the Transmit or Receive light turns on.

EOB (End-of-Block) Key (Checking Special Feature)

This key is used to signal the end of a unit-block of text. Pressing this key (Figure 4) initiates a signal that causes the block of text just transmitted to be checked at the receiving terminal. This check does not provide an indication of accuracy as a typist, since typed copy can be checked, but it does ensure that all characters that were typed on your keyboard have reached the receiving terminal correctly.

Immediately following the operation of the EOB key, the Restart light turns on and the status lights change from transmit to receive momentarily, and then back to transmit, indicating that checking has been completed. If an error occurred, the Restart light remains on and the keyboard locks. Pressing the Restart key turns the light off, unlocks the keyboard, and allows you to retransmit the message (if necessary), or to continue message transmission. Pressing the EOT key also turns the light off, causes a © to be transmitted, and places the terminal in control receive mode. If the message was received correctly, the Restart light turns off automatically.

Automatic EOB (Prerequisite, Checking Feature)

Included with this feature is a three-position switch Auto Ck (auto check) located on the left side of the 2740 cabinet (Figure 1). The three positions of the switch are: Term (terminal), Mplx (multiplexer), and Off. Set the switch to Term when transmitting to another terminal and to Mplx when transmitting to a multiplexer. With the switch set to Term or Mplx, each operation of the Return key causes the carrier to return and the EOB/LRC sequence to be transmitted automatically, thereby causing the line of characters just transmitted to be checked at the receiving terminal. Your terminal shifts momentarily from transmit to receive status (Transmit light turns off, Receive and Restart lights turn on). If the receiving terminal responds with a positive answer, your terminal shifts back to transmit status (Transmit light turns on, Receive and Restart lights turn off, and keyboard unlocks) and you can continue with message transmission.

If the message is received incorrectly, the receiving terminal prints a hyphen (below the message block just completed) and a negative response is sent back to your terminal. This negative response causes a hyphen to print (below the message block just completed) at your terminal. The negative response also locks your keyboard, turns the Transmit light on, sounds the audible alarm, and causes the Restart light to remain on. The message can be retransmitted by pressing the Restart key. Operating this key turns the Restart light off, causes a CR/LF (carrier return and line feed) to occur at your terminal, and another CR/LF to occur at the receiving terminal if the switch is set to the Term position. If the switch is set to the Mplx position, the CR/LF code is not transmitted to the receiving terminal. The CR/LF operation positions the carrier on a new line (below the hyphen). The message can now be retransmitted.

When the switch is set to Off, the EOB key must be manually operated to initiate a record check (see Automatic EOB under Special Features, Model 1).

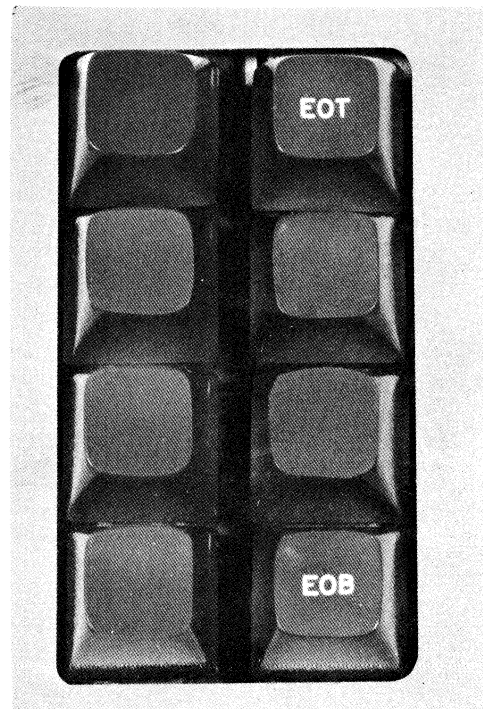

Figure 4. IBM 2740 Model 1 Transmission Controls (Left Side of Keyboard)

EOT (End-of-Transmission) Key

After typing the contents of a message on your keyboard, signal the other terminals that you have completed your message. Operating the EOT key (Figure 4) transmits a signal to all terminals that have received your message, causing them to shift to standby status (Standby light turned on and Receive light turned off). Operating the EOT key also causes your terminal to shift to standby status (Standby light turned on and Transmit light turned off).

Transmit-Control Switch (MTC, Off) Transmit Control Special Feature

This switch is located on the left side of the 2740 cabinet (See Figure 1). The two settings of this switch (MTC--Multiplexer Transmit Control, and Off) provide or inhibit the proper line-control signals for the transmit-control feature when operating between a 2740 and a multiplexer. With this switch set to the MTC position and in control receive mode,

the terminal shifts to transmit status when the multiplexer transmits a special two-character code (/ space). The Off position of this switch places the transmit-control feature in an inactive status. (See Transmit Control under Special Features, Model 1.

Test Switch

The Test switch is present only on terminals using certain IBM Leased or Shared Line Modems (special feature) to connect to the communications line. The Test switch, labeled Mod (Modem), Line and Off is used when communication cannot be established with a remote terminal. Refer to IBM 2740 Terminal and Line Adapter Test Procedure under Test Procedures in the IBM 2740/2741 Communication Terminal Operator's Guide, Form A27-3001 for test procedure and use of this switch.

This section covers the operation of the basic IBM 2740 Communication Terminal Model 1, without any special features, and then with special features installed. The communication line operations required for each are shown in Figures 5 through 15. A detailed description of operating procedures is included in the IBM 2740/2741 Communication Terminal--Operators Guide, Form A27-3001.

The IBM 2740 Communication Terminal is a modified Selectric typewriter that retains its basic typing features for both local and communicate mode operations (Figure 2). The significant differences in the typewriter are in the addition of transmission controls and indicators on either side of the typing keyboard, and in the standardization of the available print elements to conform with those available with other IBM terminals (e. g. , IBM 1050). This means that the 2740 can interchangeably use the print elements provided with the PTTTC/BCD and the PTTTC/EBCD codes unless the standard Selectric typewriter print element was specified at the time of ordering. (Refer to "Interchangeable Print Elements" in the introductory section.) See Appendix for a full description of these codes, associated keyboards, and the various character sets available.

In addition to the Selectric features previously discussed (stroke storage, typamatic index key, interchangeable print elements, and the compact ribbon cartridge) this typewriter has:

- 10 or 12 characters per inch horizontal spacing.
- 15 1/2 inch paper-width capacity.
- 13 inch wide writing line with a standard friction platen.
- pin-feed platen is available as a special feature.
- 6 or 8 lines per inch vertical spacing (6 lines is standard).

The standard 2740 Model 1 is designed for point-to-point operations using a private line (leased private line or privately owned line) between two 2740 terminals or a 2740 terminal and a multiplexer. However, the computer program must be designed to handle the basic line-control signals used with this type of operation (Bid character, $\text{\textcircled{D}}$, and End-of-Transmission, EOT $\text{\textcircled{C}}$ Refer to "Line Control Signals" in this manual for a complete explanation of all signals.

These two line-control signals also permit a broadcast type of operation. In this operation, a message transmitted from one terminal is received by all terminals on this line. Installation of an available special feature additionally allows terminal-to-computer operation on a multipoint basis (more than one 2740 terminal on a communication line).

Point-to-Point Operation (Terminal-to-Terminal)

This operation is performed on a contention basis, which means that both terminal operators independently attempt to acquire the line by pressing the Bid key (Figure 5). The first terminal acquiring the line retains control of this line until its EOT key is pressed. (Refer to Transmission Controls and Indicators, Model 1 in this section of manual, for a complete explanation of these keys.) When a terminal acquires the line, the other terminal automatically switches to a receive status and its keyboard is locked. This terminal remains in the receive status until an EOT code is received.

Before attempting to acquire the line, each terminal is in one of the following conditions:

- Standby status (communicate mode)
- Typing status (local mode)
- Off

Transmit

Before attempting to acquire the line, the terminal must have status; this requires:

- On-off switch (located on the keyboard) must be on.
- Paper must be properly inserted in the typewriter to close the paper-presence contact. (This contact can be deactivated by using the contact lockout.)
- Local/Communicate switch must be positioned to Communicate.
- Power must be supplied to data set (if used).

As a result, the Standby light will be on. The following operation can now be performed:

- Press the Bid key. This transmits a \textcircled{D} signal to the other terminal on the line (Figures 5 and 6). Upon receipt of the \textcircled{D} signal, the receiving terminal automatically switches to receive status provided the terminal was originally in standby status. This change to receive status causes the keyboard to remain locked and the terminal motor to be turned on. If this terminal is operating in local mode or is not in standby status when the \textcircled{D} signal is received, an audible alarm is automatically sounded at the terminal.

Once the initiating terminal acquires the line through use of the Bid key, it automatically switches to transmit status. In conjunction with this, the Transmit light is turned on, the keyboard is unlocked to permit the transmission of text, and the terminal motor is turned on. This terminal can now transmit a message (or messages) of any length and retain control of the line until it signals an End-of-Transmission (EOT).

- Press the EOT key. This transmits an EOT \textcircled{C} signal to the receiving terminal. Both terminals (the transmitting, as well as receiving) switch to a standby status. The Standby light at both terminals is turned on, the keyboards are locked (except for the Bid key and EOT key), and both terminal motors are turned off.

- Receipt of the \textcircled{D} signal switches this terminal to receive status (Receive light on, keyboard locked, and motor turned on). The terminal remains in this status until an EOT signal is received (see Figures 5 and 6). However, if this terminal runs out of paper while receiving, or drops status for any other reason, it switches to a no status condition (all status lights off, keyboard locked, and still in communicate mode). Until this condition is corrected (by inserting paper or deactivating the paper presence contact) and the line connection is re-established, the terminal is unable to receive any further transmissions. Thus, a procedural requirement providing for message retransmission when this occurs should be established for each system.

- Receipt of the EOT signal switches this terminal to standby status (Standby light on, keyboard remains locked except for the Bid and EOT keys, and the terminal motor is turned off).

- If this terminal is in the local mode or is in communicate mode but out of paper when the \textcircled{D} signal is received, an alarm sounds at this terminal. The operator should now switch to the communicate mode (by positioning the Communicate/Local key to Com), or insert paper (or deactivate the paper-presence contact). Message reception is not possible until this is accomplished.

Receive

The initial requirement for this terminal is that it be in standby status. In order to have Status, the terminal and data set must have power supplied, and the terminal must be in communicate mode with paper present in the typewriter.

Broadcast Operation

This operation (without any special features installed) is essentially the same as a point-to-point

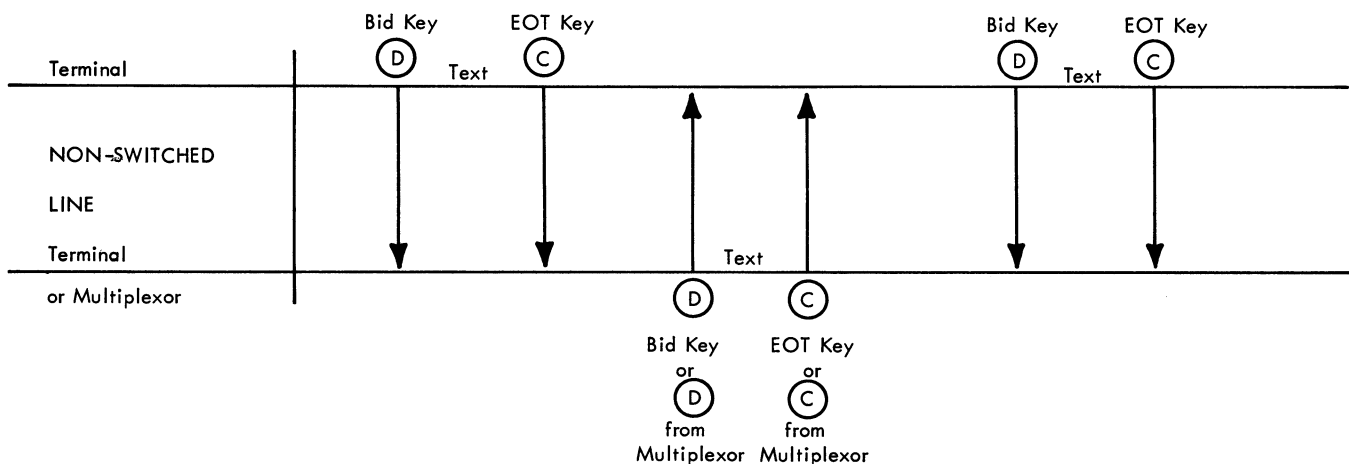

Figure 5. Point-to-Point Operation (No Special Features)

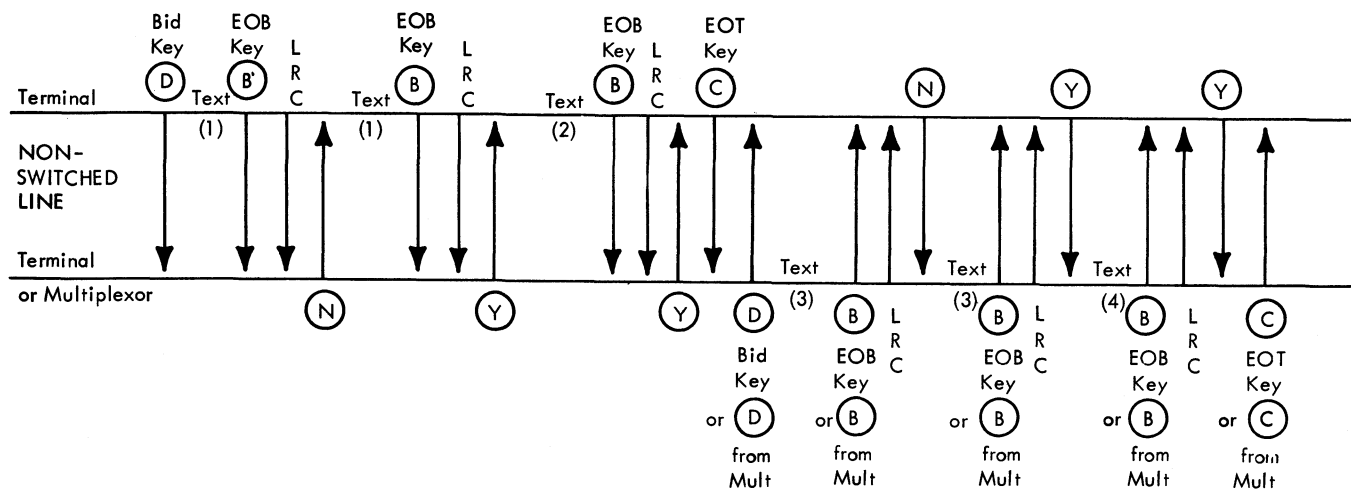

Figure 6. Point-to-Point Operation (With Checking Special Feature)

operation. The basic difference is that now message transmission is on a broadcast basis (Figure 7). Thus, all terminals on this line, in a ready condition and in a standby status, switch to a receive status when the (D) signal from the initiating terminal is received. All terminals now in receive status accept and print all transmitted messages, until an EOT signal is sent from the transmitting terminal, or until terminal runs out of paper (paper presence contact not locked out). At this time, all terminals switch to a standby status.

NOTE: The checking special feature is not available for broadcast operation.

Dial-Up Operation

This type of operation requires that each terminal have the dial-up adapter special feature installed. This feature permits the terminal to be interconnected to common-carrier switched networks by means of common-carrier provided data sets. Refer to Dial-Up Adapter in the Special Features, Model 1 section for a detailed explanation.

Dial-up is essentially the same as point-to-point operation except for the type of communication facilities employed. Since a dial-up operation connects the terminal to a line accessible to the general public, this line connection must be dropped when message transmission is completed. (For a private line, however, the connection to the terminal is permanently assigned).

The dial-up line connection is dropped by use of the Dial Disconnect key at one of the terminals (or if the status is lost). With the automatic disconnect feature (supplied by the common carrier when the

data set is installed or by a 2740 Model 1 special feature on IBM World Trade machines), operating this Dial Disconnect key at one terminal disconnects both ends of the line (Figure 8). Refer to Dial Disconnect Key and Dial Connect Light under Transmission Controls and Indicators, Model 1 in this section of the manual.

Dial-Up Operation (with checking)

This operation (Figure 9) is similar to the previously described dial-up operation, except that both terminals must have the checking special feature (VRC--Vertical Redundancy Checking, and LRC--Longitudinal Redundancy Checking) in addition to the dial-up adapter special feature installed. Provided with the checking feature is the EOB key and the Restart key and light (refer to Transmission Controls and Indicators, Model 1 in this section of the manual for a detailed description of these items).

With checking installed, each transmitted character is checked for parity (an odd number of bits) as it arrives at the receiving terminal (VRC). Any character in error is not printed. Instead, a hyphen character (or an underscore if in upshift) is printed in its place, and message reception continues. A different character is printed on IBM World Trade machines. Also, at the end of each message block, the total message block is checked by an LRC comparison at the receiving terminal.

If either a VRC error or an LRC error is detected in a message block, a hyphen character is printed at both terminals (following the LRC comparison). Also, the transmitting terminal keyboard is locked (while the receiving terminal keyboard re-

mains locked), the Restart light is turned on, and the audible alarm sounds at the transmitting terminal. The Transmit light will remain on.

The Bid and EOT keys are used the same in this operation as previously described. However, the EOB key now permits the transmitting terminal operator to designate blocks of data by pressing this key when desired. When the EOB key is pressed, an LRC comparison occurs automatically following this action. The transmitting terminal is notified of the check results by receipt of either a positive answer, Yes (Y), or a negative answer, No (N). The transmitting terminal is then either available for further transmissions (Transmit light on), or the keyboard is locked (with the Restart light and the Transmit light on). In the second instance, further transmissions cannot occur until the Restart key is pressed, turning out the associated light and unlocking the keyboard.

The line connection is dropped by operating the Dial Disconnect key at one of the terminals (or if either terminal runs out of paper). Operating this key has no effect when the terminal is in transmit status.

Point-to-Point Operation--Multiplexer and Terminal

When operating point-to-point with a multiplexer, the 2740 Model 1 terminal operates basically the same as when operating point-to-point with another 2740 Model 1 terminal. See "Point-to-Point Operation (Terminal-to-Terminal)" in this section of the manual.

Transmit

Press the Bid key. This transmits a (D) signal to the multiplexer (Figures 5 and 6). This signal causes the multiplexer to automatically switch to a receive status. Once the terminal acquires the line through use of the Bid key, it automatically switches to a transmit status. In conjunction with this, the transmit light is turned on, the keyboard is unlocked to permit the transmission of text, and the terminal motor is turned on. The terminal can now transmit a message (or messages) of any length and retain control of the line until it transmits an EOT (C) signal. Press the EOT key. This transmits a (C) signal to the multiplexer and places the terminal in a standby status. The Standby light at the terminal is turned on, the keyboard is locked (except for the Bid key and EOT key), and the motor is turned off.

Receive

The multiplexer initiates a transmission by placing a (D) signal on the communication line, which causes the terminal to switch from a standby status to a receive status (Figures 5 and 6). The Standby light turns off, the Receive light turns on, the keyboard is locked, and the terminal motor is turned on.

NOTE: One Idle character must follow the (D) to enable the terminal motor to attain full speed.

The terminal remains in this status until a (C) signal is received from the multiplexer, or until terminal

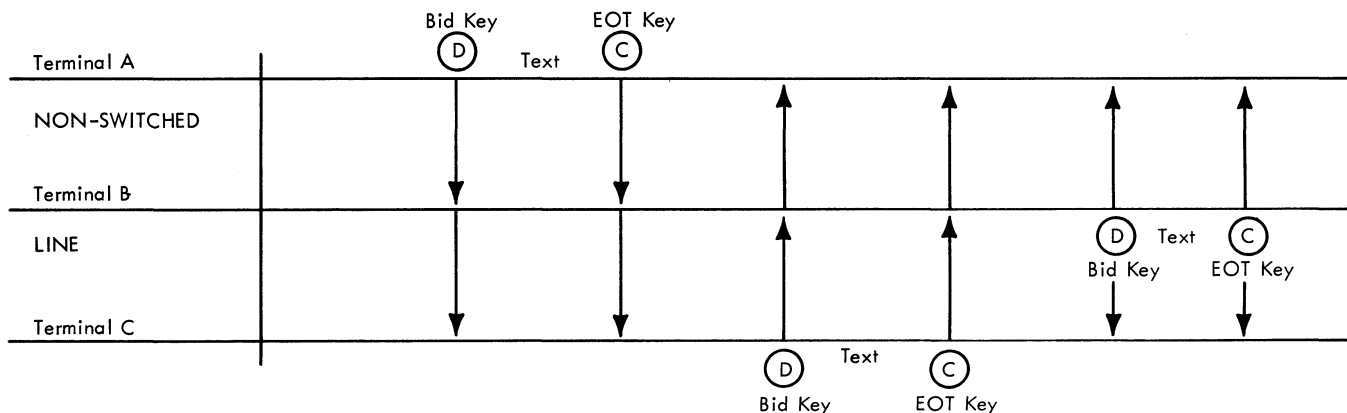

Figure 7. Broadcast Operation (No Special Features)

runs out of paper (paper presence contact not locked out).

The (C) signal switches the terminal to standby status (Standby light on, keyboard remains locked, except for the Bid and EOT keys, and the terminal motor is turned off).

If the terminal is in local mode (or is in communicate mode but without Status) when the (D) signal is received, an alarm sounds at the terminal. The operator may now switch to the communicate mode (by positioning the Local/Communicate switch to Com) or insert paper. Message reception from the multiplexer is not possible until this is accomplished.

Point-to-Point Operation--Multiplexer and Terminal with Dial-Up Feature Installed

The dial-up operation of a terminal and multiplexer is essentially the same as a point-to-point terminal and multiplexer operation without the dial-up feature installed. When the dial-up feature is used, a communication line connection must be established before the terminal and multiplexer can communicate with each other (Figures 8 and 9). The terminal must be in a standby status before attempting to make a line connection.

Transmit

Before transmitting from the terminal to the multiplexer, a communication line connection must be established in the following manner. Lift receiver, press Talk button on data set, and dial the multiplexer. The data set at the multiplexer should be equipped with the auto-answer feature. This feature places a high-pitched tone on the line when the multiplexer is called (provided the Auto button on

the multiplexer data set has been operated previously), which indicates that a line connection has been established.

Press Data button on terminal data set and place receiver in cradle. The Dial-Connect light will be on indicating the line is connected and the terminal is in a standby status. From this point on, the operation of the terminal is the same as a terminal-to-multiplexer operation without the dial-up feature (see "Point-to-Point Operation--Multiplexer and Terminal" in this section of manual and Figures 5 and 6). While the terminal is in a receive or transmit status the Dial-Connect light is off, even though the line is still connected. The light turns on again when the terminal switches to a standby status.

At the completion of transmission, the line must be disconnected as follows. Press Dial-Disconnect key; this disconnects the line at both the terminal and the multiplexer, provided both data sets have the automatic disconnect feature installed. Auto disconnect is available as a terminal special feature on IBM World Trade machines.

Receive

To receive from the multiplexer, the terminal must be in a standby status with the Auto button on the data set pressed down. The auto-call capability of the multiplexer data set (special feature) enables the multiplexer to call the terminal automatically. The Auto button on the data set (having previously been operated) enables the terminal to answer the incoming call automatically, establish a line connection, and turn the Dial-Connect light on. Once the line connection is established, the multiplexer transmits a (D) signal, which switches the terminal to a receive status.

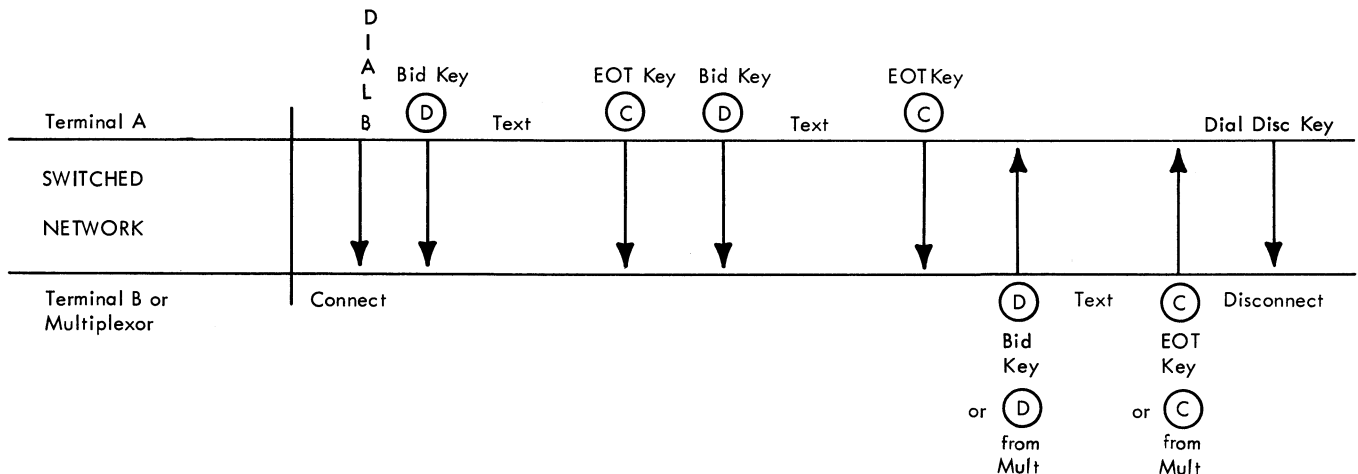

Figure 8. Dial-Up Operation (Dial-Up Adapter Special Feature)

NOTE: One Idle character must follow the (D) to enable the terminal motor to attain full speed.

The Standby and Dial-Connect lights turn off, the Receive light turns on, the terminal motor turns on, and the keyboard locks. The terminal is now conditioned to receive the data transmitted by the multiplexer.

At the completion of transmission the communication line can be disconnected automatically by the multiplexer (if the Auto-Disconnect feature is installed on the multiplexer data set), or by operating the Dial-Disconnect key at the terminal.

Transmit Control--Multiplexer

See Transmit Control Under Special Features, Model 1 in this section of the manual and also 2740 Terminal and Multiplexer with Transmit Control Feature Installed in the IBM 2740/2741 Communication Terminal--Operator's Guide, Form A27-3001.

Station Control--Multiplexer Addressing and Polling

See Station Control under Special Features, Model 1 in this section of the manual and also 2740 Terminals and Multiplexer--Station Control Special Feature Installed in the IBM 2740/2741 Communication Terminal--Operator's Guide, Form A27-3001.

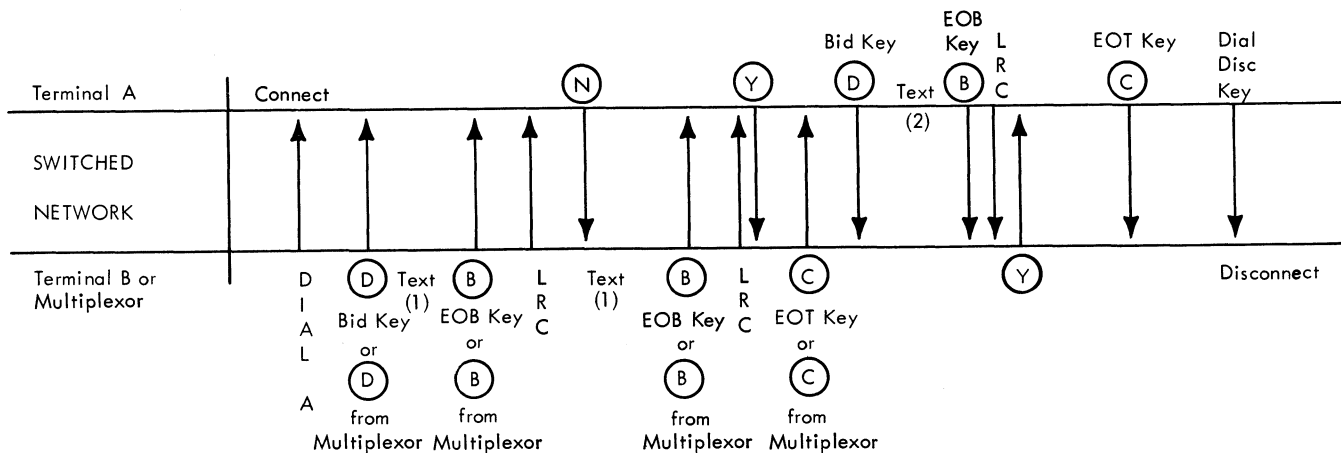

Figure 9. Dial-Up Operation with Checking (Dial-Up Adapter and Checking Special Features)

Dial-Up Adapter

With this special feature installed, the 2740 can communicate with another 2740 terminal or with a multiplexer over common-carrier switched networks. This feature permits interconnection of the appropriate common-carrier data set and line facilities with the terminal. Included with this feature is a Dial Connect light which is on when a line connection is established while in the standby status, and a Dial Disc (disconnect) key which permits disconnecting the terminals at both ends of the line by operating this key at only one terminal (provided the terminal is not in transmit mode).

NOTE: Disconnecting the terminals at both ends of the line with the operation of either of the Dial-Disc keys is possible only if the common-carrier data sets have the auto-disconnect feature installed, or, in the case of IBM World Trade machines, the terminal is equipped with the auto-disconnect special feature.

Once the line connection is established, it remains intact (regardless of EOT and Bid key operation) until the Dial Disconnect key is pressed at one of the two terminals, or until one of the terminals loses status (see Figures 8 and 9). If a line connection is established between a terminal and a

multiplexer, the multiplexer also has the ability to disconnect the line.

Any dialed terminal with this feature installed is prevented from answering if an out-of-paper condition exists, the terminal is in a local mode, or the terminal power is off (no status). However, if the terminal is called while operating in the local mode, the telephone bell sounds at the called terminal (providing the data set has been left in Talk mode, or in Auto mode if the data set has the Automatic Answering feature installed).

NOTE: This feature cannot be used if the station control special feature is installed.

Transmit Control (Prerequisite, Dial-Up Adapter Feature)

This special feature permits a multiplexer to control the send/receive status of a remote terminal. When the multiplexer transmits a special two-character control code (/ space), the terminal shifts to transmit status and sends a (D) to the multiplexer. The (D) code shifts the multiplexer to receive status. (Figures 10 and 11).

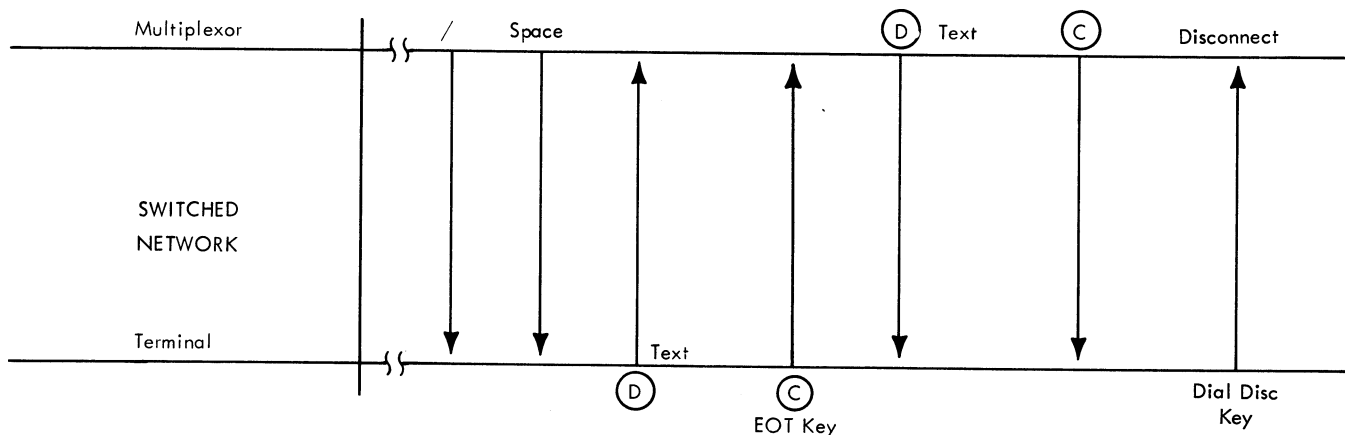

Figure 10. Multiplexer Transmit Control (Without Checking)

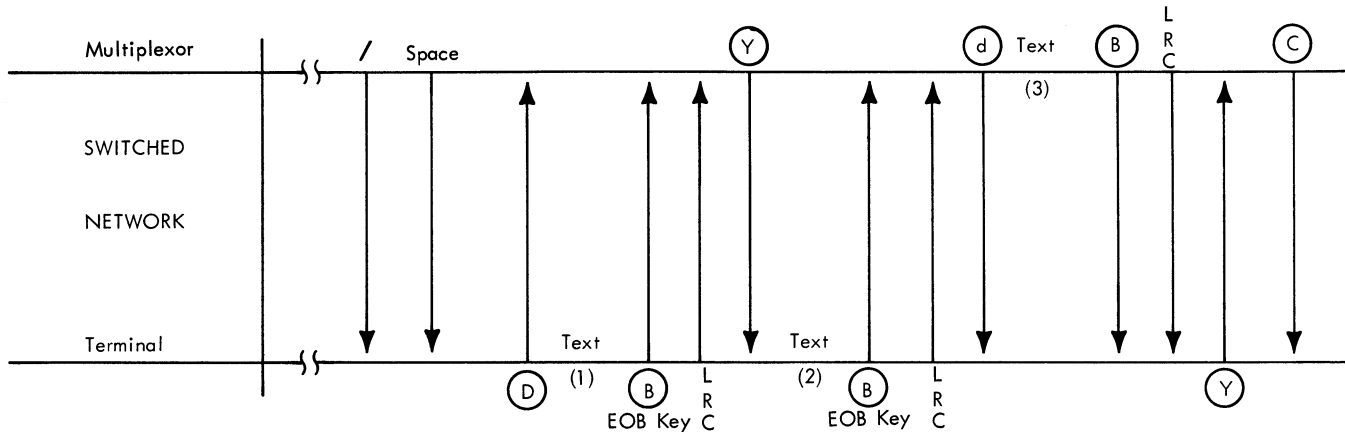

Figure 11. Multiplexer Transmit Control (With Checking Special Feature)

NOTE: The / (slash) character is used with the PTTC/BCD and PTTC/EBCD codes. A lower case x is used with the Correspondence code. However, in each one the transmission bit value (AC1) is the same.

An alarm is also turned on at the terminal to alert the operator that the transmission of text can begin. This feature can be installed only with dial-up line facilities for point-to-point operation.

After an EOT code is transmitted the terminal reverts to a standby status. If no transmission occurs from the terminal for a period of 15 seconds, while in transmit mode, the terminal times out and reverts to a standby status. This status is indicated at the terminal by the Standby light and the Dial Connect light on. The line connection is maintained between the terminal and multiplexer until: (1) a dial-disconnect operation is initiated by pressing the Dial Disc key at the terminal, (2) the terminal loses status, or (3) the multiplexer drops the line. In addition, if the terminal fails to receive a carrier signal due to a faulty line, when the data set is in the data mode, the terminal will disconnect after approximately 15 seconds. Until one of these dial-disconnect operations occurs the terminal and multiplexer can communicate with each other as controlled by the multiplexer.

Provided with this feature is a Transmit Control switch (MTC, OFF) located on the left side of the 2740 cabinet (see Figure 1). This switch permits the operator to set up the terminal for proper line control when communicating with a multiplexer (MTC) using the transmit control code (/ space). The OFF position inhibits the terminal from recognizing the two-character control code. The 15 second

time-out is still active in this case if the terminal is in transmit status and fails to transmit for 15 seconds; however, in addition to reverting to a standby status, the terminal will automatically transmit an EOT $\text{\textcircled{C}}$ signal.

NOTE: This feature cannot be used when an IBM 2760 Optional Image Unit is attached to the 2740 terminal.

Automatic Disconnect Feature (World Trade Only)

This feature is used with the IBM World Trade Modem to insure that a communication line is not left open because of a transmission interruption, a wrong-number call, or because the telephone handset has not been cradled (hung up). It permits the 2740 terminal to automatically disconnect the line under the following conditions:

1. When a valid character has not been received for approximately 15 seconds.
2. When the operator has not transmitted a valid character for approximately 15 to 30 seconds.
3. When the received carrier has been interrupted for approximately 15 seconds.

When automatic disconnect occurs, an audible alarm will sound briefly at the terminal, and the Receive and Transmit lights will turn on simultaneously. The lights are extinguished and the automatic disconnect condition is reset at the terminal when the terminal operator keys an EOT.

Checking--Parity (VRC) and Block (LRC)

This feature consists of VRC (Vertical Redundancy Checking) and LRC (Longitudinal Redundancy Checking). Thus, with this feature installed, each transmitted character is checked for correct parity (odd number of bits) at the receiving terminal, and each message block is checked for correct transmission.

NOTE: The feature is a prerequisite when an IBM 2760 Optional Image Unit is attached to the IBM 2740 Communication Terminal, Model 1.

VRC

Each character transmitted by the 2740 must contain an odd number of bits. As each character is generated at the keyboard, an additional bit (C-bit) is inserted into all even bit characters. The parity checking of each transmitted character is performed by the receiving terminal.

Any parity error received is printed as a hyphen or underscore character. The character printed on IBM World Trade machines depends upon the print element used and the error condition is remembered by the receiving terminal. When the transmitting station sends an EOB/LRC sequence, the receiving terminal replies with either a positive or negative response to the transmitting station (see Figure 9).

A negative answer to the checking sequence causes a hyphen or underscore to print at both the transmitting and receiving terminals. In addition, the Restart light and audible alarm are turned on at the transmitting terminal. The operator of the transmitting terminal then chooses to ignore the error or to resend the message to correct the error. In either case, the Restart key at the transmitting terminal must first be pressed before transmission can continue. The EOT key can also be used to recover

from the error condition. Operating the EOT key causes the transmitting terminal to send a (C) which places both terminals in standby status.

LRC

During transmission, each terminal (transmitting and receiving) records the bit structure of each character. The LRC counter at each terminal is started by the transmission of an EOA (D) signal which indicates the start of a message. The bits of all the characters of the message which then follow are recorded at both terminals until the EOB (B) signal is transmitted. This signal causes the contents of the transmitting terminal LRC counter to be sent to the receiving terminal (Figure 9).

At the receiving terminal the two LRC characters are compared. If these characters are equal (and there is no parity error), a positive answer is sent to the transmitting terminal. This permits the transmission of further message blocks.

If the LRC characters are unequal (or a parity error has been received), a negative answer is returned to the transmitting terminal and a hyphen or underscore is printed at both terminals. The audible alarm and Restart light are also turned on at the transmitting terminal. The Restart key must be operated at this terminal before transmission can continue. The EOT key can also be used to recover from the error condition. Operating the EOT key causes the transmitting terminal to send a (C) which places both terminals in standby mode.

Station Control (Multiplexer Addressing and Polling)

This feature provides the terminal with the ability to be addressed (a signal indicating "Prepare to receive"), or to be polled (a signal indicating, "Prepare to send") from the multiplexer (Figures 12, 13,

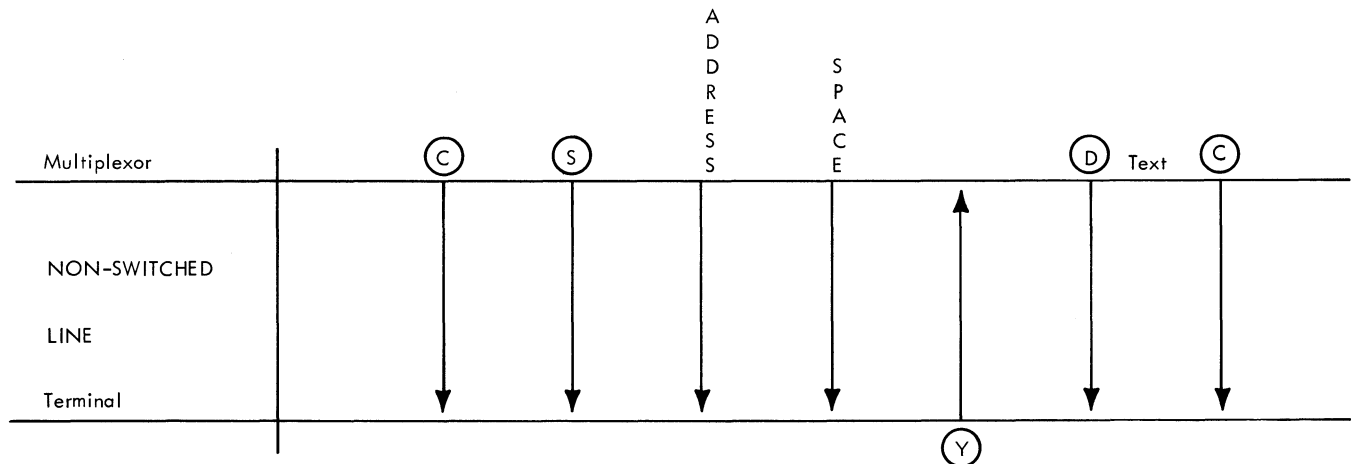

Figure 12. Station Control (Multiplexer Addressing, Without Checking)

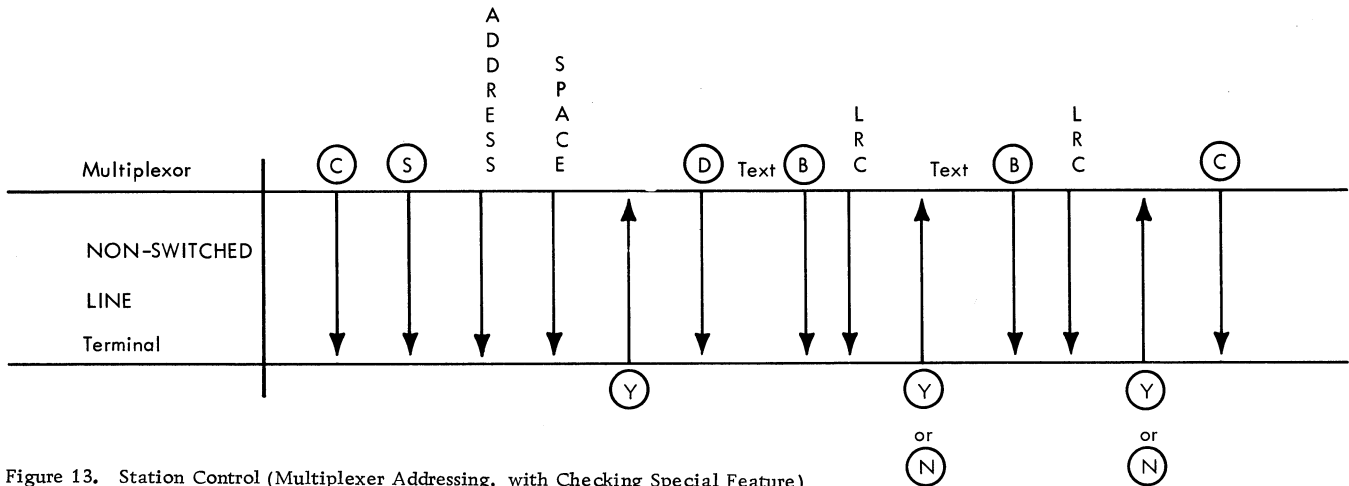

Figure 13. Station Control (Multiplexer Addressing, with Checking Special Feature)

14, and 15). The terminal can be attached to either a leased private line or a privately owned line when using this feature.

NOTE: Each 2740 master terminal (either group or all call), requires its own local loop when using a 4-wire leased or shared line IBM Line Adapter. A local loop is considered to be the communication line between the common-carrier connecting office and the customer's 2740 terminal installation. This local loop cannot be shared by other 2740 terminals. Subordinate 2740 terminals will fail to print the first text character following an EOB/LRC sequence if they are on the same local loop as the master terminal.

All communication in the multiplexer operation is centralized (from the terminals to the multiplexer and from the multiplexer to the terminals). The multiplexer does all the necessary polling and addressing. Anytime there is no transmission from a terminal (in transmit status) for a fifteen second time period, a time-out occurs and the terminal shifts to standby status.

Each terminal is assigned a single character identification code (either alphabetic A-Z, numeric 0-9, or any five additional characters). When using the PTTC/BCD and PTTC/EBCD codes, the five additional characters are: @, -, \$, ., and &. When using the correspondence code, the five additional characters are: t, !, w, j, and -. This identification character is specified by the customer and wired by IBM personnel at installation time. This character assignment is always followed by the Space Character to form a two-character polling or addressing sequence which permits each 2740 terminal sharing a specific communication line to recognize its unique station identification. When this recognition occurs, the terminal participates in

either a polling operation (transmitting), or an addressing operation (receiving), as designated by the transmitted line-control codes. The remaining terminals are prevented from using the line until the present transmission is completed.

In addition to the primary identification character, a secondary identification character can be assigned to each terminal in a designated group at the time of installation. Using this character permits group addressing (simultaneously addressing all stations in the group). The secondary (group) identification character is always followed by the Space character to form a two-character addressing sequence. The specific group assignments are completely flexible within the terminals on any one communication line. However, the group identification character assigned must not conflict with the assigned terminal identification characters on this communication line. A station is limited to one group identification character. For example, if three terminals are used on a communications line, and they are to be addressed individually and also as a group, the addressing sequence could be as follows:

	<u>Individual Identification Character</u>	<u>Group Identification Character</u>
Terminal 1	A Space	D Space
Terminal 2	B Space	D Space
Terminal 3	C Space	D Space

One terminal (Master terminal) within the group is preselected to provide the necessary checking and

addressing responses for the group.

All-call addressing (transmitting to all stations on the line simultaneously) is accomplished by the transmission of a special two-character code (/ space).

NOTE: The / (slash) character is used with the PTTC/BCD and PTTC/EBCD codes. A lower case x is used with the Correspondence code. However, in each case the transmission bit value (AC1) is the same.

When this code is received, all terminals shift to receive status. One terminal is preselected to provide the addressing and checking responses for all terminals.

NOTE: The Station Control feature cannot be used if the Dial-Up Adapter special feature is installed.

Automatic EOB (Prerequisite, Checking Feature)

This feature provides a three-position switch located on the left side of the 2740 cabinet (see Figure 1). The three positions of the switch are: Term (terminal), Mplx (multiplexer), and Off. The switch is set to the Term position when transmitting to another terminal and set to the Mplx position when transmitting to a multiplexer.

When this switch (on the transmitting station) is set to the Term or Mplx position, an EOB code followed by an LRC character is automatically transmitted directly after the CR/LF code each time a carrier return is keyed.

At the receiving station, the EOB/LRC sequence is received and either a positive (Y) or negative (N)

answer is returned to the transmitting terminal. In the first instance, normal transmission continues. If, however, an error is detected in this message block, a hyphen is printed below the message block just completed (receiving 2740 terminal only), and a negative answer (N) is returned to the transmitting terminal. This (N) signal causes a hyphen to print below the message block just completed at the transmitting terminal. The (N) signal also locks the keyboard at the transmitting terminal, turns on the Restart light, and sounds the audible alarm.

The message can be retransmitted by initially pressing the Restart key. This unlocks the keyboard and turns the Restart light off. Operating this key also causes a CR/LF to occur at the transmitting terminal, and a CR/LF to occur at the receiving terminal, if the switch at the transmitting terminal is set to the Term position. If the switch is set to the Mplx position, the CR/LF code is not transmitted to the multiplexer. The CR/LF operation positions the carrier on a new line (below the hyphen). The message can now be keyed again.

When the switch is off, the EOB/LRC sequence can be initiated only by manually pressing the EOB key.

If the receiving terminal does not have the Automatic EOB feature installed, the printing position of the hyphen is altered at this terminal. In this case, the hyphen is printed at the receiving terminal during the carrier return (in-flight printing). This places the hyphen within two inches of the right margin (or point of carrier return initiation). The printing position of the hyphen character at the transmitting terminal is not altered.

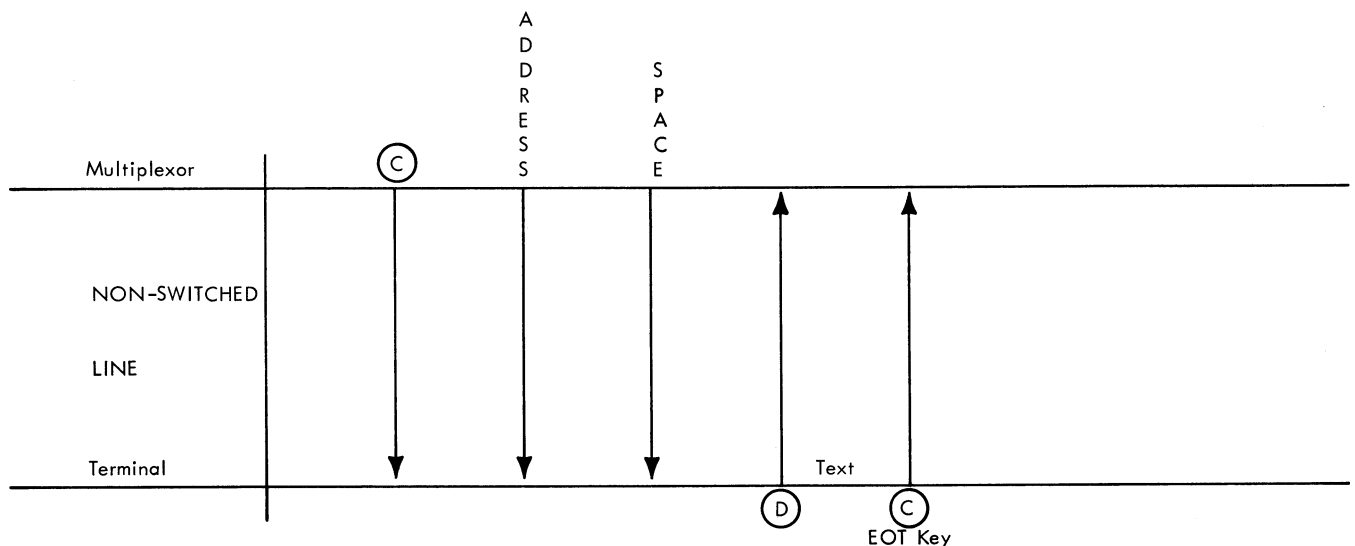

Figure 14. Station Control (Multiplexer Polling, without Checking)

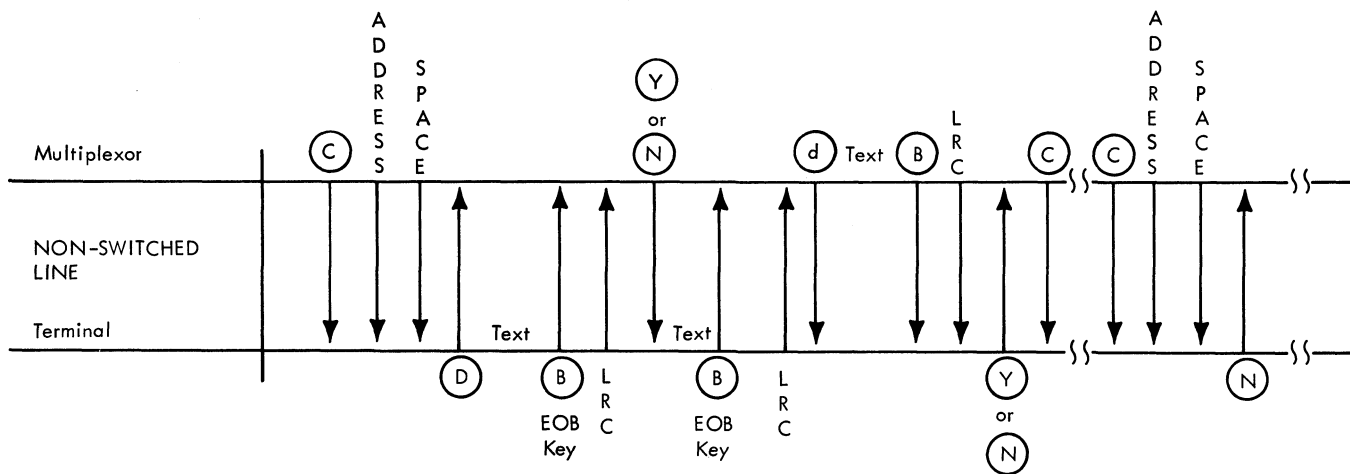

Figure 15. Station Control (Multiplexer Polling, with Checking Special Feature)

IBM 2760 Attachment

This feature is required when an IBM 2760 Optical Image Unit is attached to the IBM 2740 Communication Terminal, Model 1.

IBM Line Adapter (Limited-Distance Type 1)

This feature permits the customer to attach an IBM 2740 Terminal to customer-installed communication lines or leased common-carrier private line channels. The line adapter feature (installed within the 2740) provides the necessary signal modulation and demodulation for transmission on two-wire or four-wire communication lines up to 4.75 miles in length with a single 2740 attached. Two versions of this line adapter are available: Type 1A for two-wire systems, and Type 1B for four-wire systems.

IBM Line Adapter (Limited-Distance Type 2)

This feature permits the customer to attach an IBM 2740 Terminal to customer-installed communication lines or leased common-carrier private line channels. The line adapter feature (installed within the 2740) provides the necessary signal modulation and demodulation for transmission on two-wire communication lines up to 8.0 miles in length.

IBM Line Adapter (Leased Line)

This feature permits the customer to attach an IBM 2740 Terminal to a leased common-carrier private

line or equivalent privately owned facility. This line adapter feature (installed within the 2740) provides the necessary signal modulation and demodulation for transmission on a communication line without length restriction.

IBM Line Adapter (Shared Line)

This feature permits the customer to attach an IBM 2740 Terminal to one of four subchannels which can be obtained from either the customer's privately owned or leased common-carrier telephone-grade communication facilities. This line adapter also provides the necessary signal modulation and demodulation required for data communications. With this feature, one telephone line can provide up to four separate paths for simultaneous data transmission. This line adapter is available for operation on either two-wire or four-wire communication facilities.

NOTE: For additional information on the use of IBM line adapters, see Planning and Installation of a Data Communications System Using IBM Line Adapters, Form A24-3435.

Pin-Feed Platens

Pin-feed platens are available in the following inch sizes for the IBM 2740 Communication Terminal Model 1 Selectric Typewriter. Any one of these platens may be ordered in place of the standard friction-feed platen.

<u>Over-all Forms Width</u>	<u>Hole-to-Hole Width</u>	<u>Writing Line</u>
5 3/4	5 1/4	4 3/4
6 1/2	6	5 1/2
8	7 1/2	7
8 1/2	8	7 1/2
9 1/2	9	8 1/2
9 7/8	9 3/8	8 7/8
10 3/8	9 7/8	9 3/8
10 1/2	10	9 1/2
10 5/8	10 1/8	9 5/8
11 3/4	11 1/4	10 3/4
12	11 1/2	11
13 5/8	13 1/8	12 5/8

Paper Guide, Tear Bar, and Roll Paper Holder

This accessory provides for mounting rolls of continuous forms or paper on the back of the typewriter. It also serves as a guide for the paper after printing has been completed. A tear bar is provided for tearing off printed matter.

TIMING CONSIDERATIONS, 2740 MODEL 1

The following timings are based on a wide variety of system configurations and applications. These timings will vary for specific applications.

Time-Out Conditions

The IBM 2740 Communication Terminal Model 1 will time out whenever any of the following conditions exist:

- If no data has been transmitted over the line for an interval of 15 seconds by a terminal in transmit status (with the Station Control feature installed). The terminal will return to a standby status and no code is transmitted.
- If no data has been transmitted over the line for an interval of 15 seconds by a terminal in transmit status (with the Transmit Control feature installed). If the transmit control switch is set to the MTC position, the terminal reverts to a standby status and no EOT (C) code is trans-

mitted. If the transmit control switch is set to the off position, an EOT (C) code is transmitted and the terminal reverts to a standby status.

- If the Dial-Up feature is used and the line connection is lost, the terminal returns to standby status. If the Dial-Up feature is used and the terminal has the Transmit Control feature installed, loss of the line connection for a period of 15 seconds causes the terminal to disconnect from the line and no code is transmitted.

Delay Conditions

When power is initially turned on, the terminal requires a delay of 0.53 to 3.09 seconds in order to reset the various circuits to home position. If Limited-Distance Type 2, Leased or Shared Line line adapters are used by the terminal, an additional delay of 4 to 10 seconds is required. If the Station Control feature is installed, an additional delay of 10.8 to 20.0 seconds is required. This delay takes place following the 4 to 10 second delay, if both features are installed (Line Adapter and Station Control). Following the delay(s), the terminal is switched to a standby status with only the control circuits active. The keyboard is locked and the typewriter motor is not running.

Typewriter Delay Conditions

The following formula is used to calculate the elapsed time (in milliseconds) when the typewriter is performing a carrier return and line feed operation (CR/LF), or a tabulate (tab) operation.

$$(1.5 + T) \times 67.5 = \text{Elapsed time in milliseconds}$$

T = The number of inches of carrier travel.

The number of idle codes required for each mechanical operation is as follows, where N is the number of codes required, and T is the number of inches of carrier travel. Round off the result to the next whole number.

$$\text{Carrier return: } N = T + 1.5$$

$$\text{Tab: } N = T + 1.5$$

$$\text{Index: } N = 1$$

The keyboard speed will vary according to the operator's typing ability, with the maximum speed not to exceed 14.8 cps (characters per second).

DATA-HANDLING CAPABILITY, MODEL 1

To compute the data-handling capability of the 2740 Terminal, Model 1, the following basic timings must be considered. They represent terminal timings only and do not include timings for operations in the computer and the transmission control unit.

Terminal Transmission and Control Speed

The speed of the 2740 terminal is 14.8 characters per second; therefore the character time is 67.5 milliseconds per character. Each character consists of a start bit, six data bits, a check bit, and a stop bit (Figure 16). Since each character contains nine bits, the speed of the terminal is 133.2 bits per second (9 x 14.8).

Addressing Time

The time required to address a terminal (735 ms) is calculated as follows:

$$(6 \times 67.5) + 330^* = 735 \text{ ms}$$

$$(6 \times 67.5) = 6 \text{ character times } (\textcircled{\text{C}}), (\textcircled{\text{S}}), \text{ address, space, response, and } (\textcircled{\text{D}})$$

$$330^* = \text{Delay before transmission of response (sample data set turn-around time). This does not include any delays at multiplexer, such as between response and } (\textcircled{\text{D}}).$$

Polling Time (Negative Answer Back)

The time required for a polling operation with negative answer back (600 ms) is calculated as follows:

$$(4 \times 67.5) + 330^* = 600 \text{ ms}$$

$$(4 \times 67.5) = 4 \text{ character times } (\textcircled{\text{C}}), \text{ address, space and } (\textcircled{\text{N}}) \text{ response}$$

$$330^* = \text{Delay before transmission of response}$$

Polling Time (Positive Answer Back)

The time required for a polling operation with positive answer back (600 ms) is calculated as follows:

$$(4 \times 67.5) + 330^* = 600 \text{ ms}$$

$$(4 \times 67.5) = 4 \text{ character times } (\textcircled{\text{C}}), \text{ address, space, and } (\textcircled{\text{D}}) \text{ response}$$

$$330^* = \text{Delay before transmission of response}$$

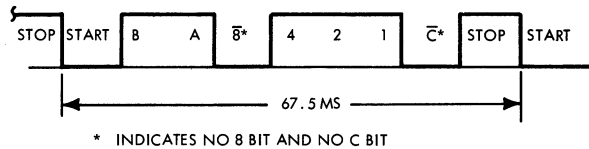

Figure 16. Bit Configuration for the Character G (PTTC/BCD and PTTC/EBCD Code)

Checking Time (Receive Terminal, Positive Answer Back)

The time required for checking at the receiving terminal with a positive answer back (533 ms) is calculated as follows:

$$(3 \times 67.5) + 330^* = 533 \text{ ms}$$

$$(3 \times 67.5) = 3 \text{ character times } (\textcircled{\text{B}}), \text{ LRC, and } (\textcircled{\text{Y}}) \text{ response}$$

$$330^* = \text{Delay before sending response}$$

Checking Time (Receive Terminal, Negative Answer Back)

The time required for checking at the receiving terminal with a negative answer back is calculated as follows:

$$(3 \times 67.5) + 330^* = 533 \text{ ms}$$

$$(3 \times 67.5) = 3 \text{ character times } (\textcircled{\text{B}}), \text{ LRC, and } (\textcircled{\text{N}}) \text{ response}$$

$$330^* = \text{Delay before transmitting response}$$

Checking Time (Transmit Terminal, Positive Answer Back)

The time required at the transmitting terminal awaiting a positive answer back from the receiving terminal (203 ms), is calculated as follows:

$$(3 \times 67.5) = 203 \text{ ms}$$

$$(3 \times 67.5) = 3 \text{ character times } (\textcircled{\text{B}}), \text{ LRC, and } (\textcircled{\text{Y}}) \text{ response}$$

NOTE: 203 ms does not include the time the receiving terminal requires to respond with the $\textcircled{\text{Y}}$ signal after receiving the LRC.

Checking Time (Transmit Terminal, Negative Answer Back)

The time required at the transmitting terminal awaiting a negative answer back from the receiving terminal (270 ms) is calculated as follows:

$(3 \times 67.5) + 67.5^* = 270 \text{ ms}$

$(3 \times 67.5) = 3 \text{ character times } (\textcircled{\text{B}}), \text{ LRC, and } (\textcircled{\text{N}}) \text{ response}$

$67.5^* = \text{Delay included in printing negative response before switching to the transmit text lock mode.}$

NOTE: 270 ms does not include the time the receiving terminal requires to respond with the $(\textcircled{\text{N}})$ signal after receiving the LRC.

*This figure may vary depending upon the type of data set used and how it is connected.



INTRODUCTION

The IBM 2740 Communication Terminal Model 2 (Figure 17) is a buffered version of the IBM 2740 Communication Terminal Model 1. The 2740 Model 2 enables key input from the typewriter keyboard (Figure 18) to be printed, stored in a buffer, visually verified, and subsequently transmitted to an IBM System/360. The basic buffer in the IBM 2740 Model 2 can accommodate up to 120 characters (248 and 440 positions are available as special features), and is capable of reading out without destroying its contents.

The IBM 2740 Communication Terminal Model 2 (without special features) transmits over leased common-carrier or privately-owned communication facilities at the rate of 14.8 characters per second. Station control is a standard function in the basic IBM 2740 Model 2 terminal, therefore the Model 2 cannot be used terminal-to-terminal. The line-control signals used by the IBM 2740 Model 2 are identical to those used for the Model 1 and the operation of the Model 2 is basically the same as the operation of Model 1.

The IBM 2740 Model 2 is designed to be used in a wide variety of applications, such as: payment entry, journal entry, inquiries, administrative messages, file updating, and renewals. The terminal can also be used off-line for other typing applications.

In addition to handling standard forms, the Model 2 can print portions of the output data on manually

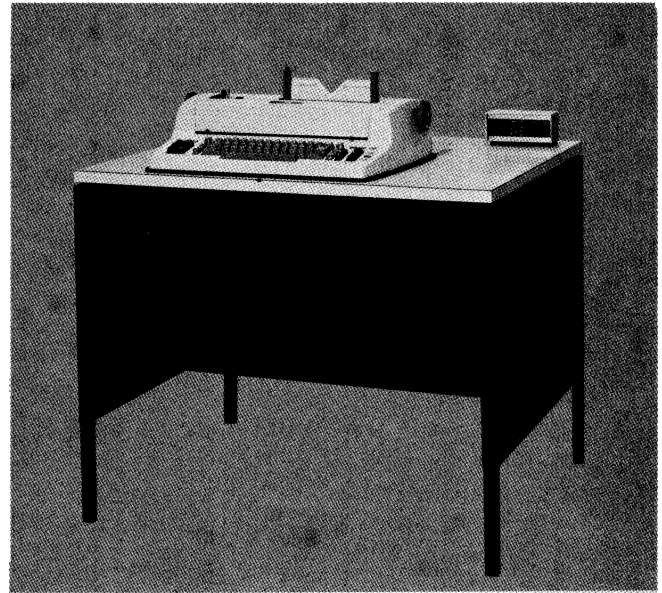

Figure 17. IBM 2740 Communication Terminal, Model 2 with Document Insertion Feature.

inserted individual forms, such as: ledger cards, checks, and single-part forms. The Document Insertion special feature provides for easy insertion and removal of the individual documents (see Document Insertion under Special Features, Model 2 in this section of the manual).

The buffer of the IBM 2740 Model 2 enhances the various application areas by providing:

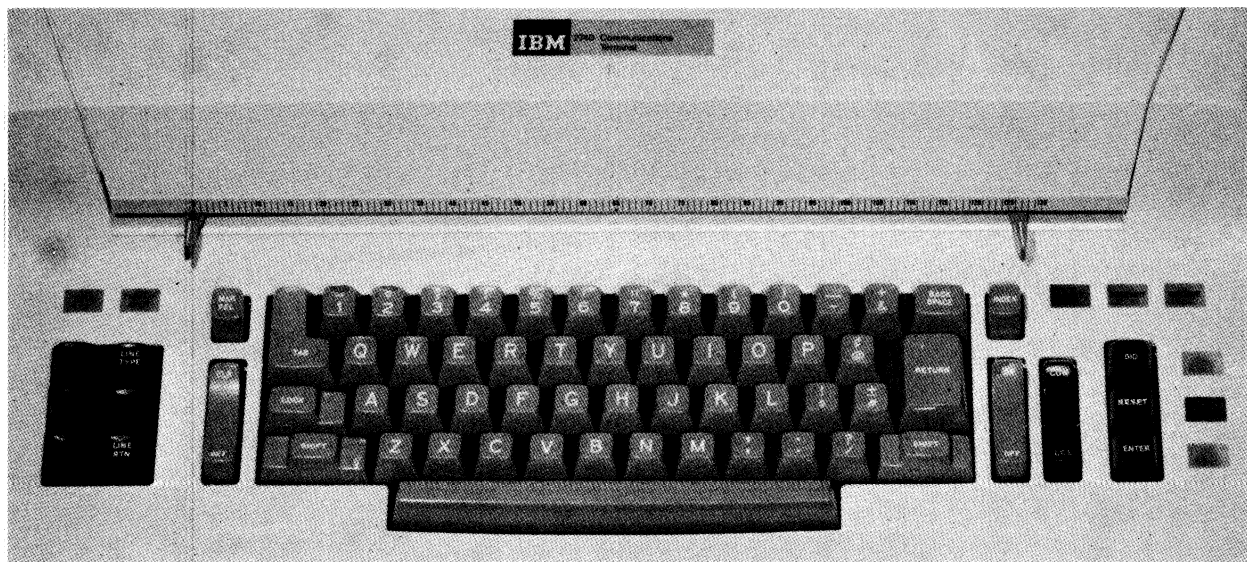

Figure 18. IBM 2740 Model 2 Typewriter Keyboard

- Faster transmission speed to and from the buffer.
- A reduction in manual entry.
- Visual verification before transmission.
- Clean copy output (with Buffered Receive feature installed).
- Ease in correction of keying errors.
- Automatic retransmission, if Record Checking feature is installed.
- Flexibility in selection of communication facilities.

COMMUNICATIONS FACILITIES

The IBM 2740 Model 2 is designed for communicating with an IBM System/360 Model 25, 30, 40, 50, 65, 75, or 85 through an IBM 2701 Data Adapter Unit, an IBM 2702 or 2703 Transmission Control Unit, or an IBM 2712 Remote Multiplexer over privately owned or leased common-carrier facilities. The Model 2 operates in a half-duplex mode only over:

- Common-carrier leased private-line telephone service.
- Common-carrier leased private-line telegraph service:
 - Telephone Company Type 1006 (150 Baud) channels
 - Telephone Company Type 1005 (75 Baud)* Channels
 - Western Union Class C (75 Baud)* Channels.
- Western Union Class D (180 Baud) Channels.
- Western Union Class E Channels, or
- Equivalent privately owned communications facilities.

*Telegraph Line Adapter (IBM special feature) is required. The channel must be capable of operating at 75 bps (bits per second) with the 9-bit-per-character code, and must be terminated in a 62.5-ma neutral dc loop at the terminal. Non-code-sensitive regenerators must also be used on the channel.

Data Sets

The IBM 2740 Model 2 operates over communication facilities using the following data sets or their equivalent:

- Western Electric Data Set 103F2--for use in multipoint or point-to-point leased private line telephone service.
- Western Electric Data Set 202D1--for use in multipoint or point-to-point leased private-line telephone service (4-wire facilities only).
- IBM Line Adapters (Limited Distance Type 1, Limited Distance Type 2, Leased Line, and Shared Line)--for use in multi-terminal or point-to-point operations on privately-owned line connections or common-carrier leased private connections. Refer to the Special Features, Model 2 section for further information.
- An appropriate channel termination for use on Telephone Company 150 baud (Schedule 1006) channels.
- Western Union Data Loop Transceiver 1183-A for use on Western Union Class D (180 baud) channels.

Line-Control Signals

The line-control signals used for the 2740 Model 2 are identical to those used for the 2740 Model 1 (See Line-Control Signals in the 2740 Model 1 section of this manual).

MODES OF OPERATION

The IBM 2740 Model 2 can operate in either local or communicate mode.

Local Mode

In local mode, the terminal will be in one of three status conditions:

Enter. Keyboard-entered data will be loaded into the buffer as well as printed.

Print Back. The contents of the buffer will print out with each operation of the Bid key.

Typewriter. The terminal may be used for normal office typing without entering or affecting the buffer (Enter key not operated prior to typing). If the terminal is polled or addressed while operating in local mode, a (N) negative-response signal is sent to the CPU. The Attention light and audible alarm also turn on when the terminal is addressed.

Communicate

When operating in communicate mode, the terminal will be in one of five status conditions:

Standby. Terminal is in a ready condition and capable of sending or receiving data; however, the keyboard is locked until an operation is initiated (see Communicate Mode under Principles of Operation, Model 2 for other conditions that lock the keyboard). If the terminal is addressed while in standby status, it responds with a (Y) positive response and shifts to receive status.

Transmit. Terminal is in the process of sending data to the communications line from the buffer.

Enter. Terminal prints and loads the operator-initiated information from the keyboard into the buffer. If the terminal is addressed while in enter status, the Attention light turns on, the alarm sounds, and a (N) negative-response signal is sent to the CPU. If the terminal is polled while in enter status, it responds with a (N) negative-response signal to the CPU.

Receive. Terminal is receiving data from the communications line or printing the received data. If the Buffered Receive feature is installed and the terminal is addressed while printing from the buffer, the Attention light turns on, the alarm sounds, and a (N) negative response is sent to the CPU. If the terminal is polled while printing from the buffer, the terminal responds with a (N) negative-response signal to the CPU.

Bid. Operator has pressed the Bid key and terminal is waiting to be polled in order to transmit the data residing in the buffer. If the terminal is addressed while in bid status, it responds with a (N) negative-response signal, and turns on the Attention light and audible alarm.

Codes, Keyboard Arrangements, and Print Elements

Since the 2740 Model 2 is designed to operate primarily with an IBM System/360 on a multipoint basis, the use of the PTTC/EBCD code (with its

associated keyboard arrangement and print element containing System/360 graphics), is recommended (see Code Charts and Keyboard Arrangements in Appendix). The PTTC/BCD code and the Correspondence code, with their associated print elements and keyboard arrangements, can be requested on an RPQ (Request Price Quotation) basis.

NOTE: The PTTC/BCD code and Correspondence code are not System/360 Type 1 program supported.

The backspace code cannot be transmitted by the Model 2 terminal and is used only for error-correction purposes prior to transmitting the message. However, backspace codes received by the Model 2 terminal from the CPU will cause normal backspacing to occur.

Transmission Controls and Indicators, Model 2

The reader should be familiar with the operation of the IBM 2740 Communication Terminal as described in the 2740 Model 1 section of this manual, and the IBM 2740/2741 Communication Terminal--Operator's Guide, Form A27-3001. Only the additional keys, lights, and switches, or those keys, lights, and switches whose functions are altered in the Model 2, are described in this section of the manual.

The (B) EOB key and (C) EOT key have been removed from the IBM 2740 Model 2 keyboard, since those signals are provided automatically; however, the (B) EOB signal is provided only if the Record Checking special feature is installed.

On/Off Power Switch

This switch (see Figure 20) controls all terminal power. Each time power is turned on, all electronic controls are reset. The buffer is reset when power is turned off.

When the terminal is attached to an active communications line, power should be left turned on. Turning power on and off places power transients on the communications line with a possibility of disrupting line operation. The typewriter motor runs only when the terminal is active and turns off automatically when the terminal is not being used.

Keys

The following keys are located to the left and to the right of the 2740 Model 2 keyboard, Figures 19 and 20.

Enter Key. The Enter key, when operated, enables keyboard-initiated data to enter the buffer in either

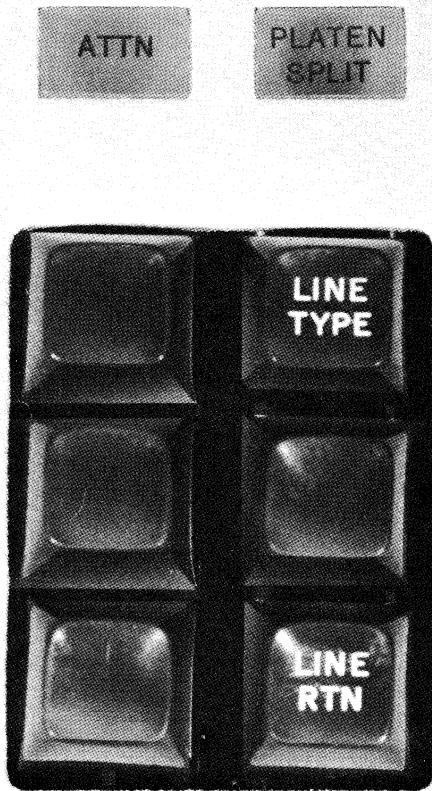

Figure 19. IBM 2740 Model 2 Operator Controls (Left Side of Keyboard)

local or communicate mode. Pressing the Enter key turns on the Enter light (located to the right of key), resets the buffer to the first position of storage, unlocks the keyboard, and places the terminal in enter status. If the terminal is polled or addressed while in enter status, a **(N)** negative-response signal is sent to the CPU. The Attention light and audible alarm also turn on if the terminal is addressed.

Bid Key. The Bid key is used to initiate the transmission of data when the terminal is in communicate mode. Pressing the Bid key turns on the Bid light (located to the right of key) and causes the contents of the buffer to be transmitted when the terminal is polled by the CPU. The bid operation will not occur if the Reset light is on. The Bid key is operational only when the terminal is in enter status or after a **(C)** is received in response to an EOB/LRC sequence. The key is operated after the **(C)** is received, when a message is to be retransmitted.

After the operator has completed keying a message, made any corrections, and pressed the Bid key, the terminal shifts to lower case (and stores the lower-

case code) if necessary. A **(B)** EOB or **(C)** EOT is entered in the buffer in the position following the last keyed character (or lower-case code, if inserted). The **(B)** is entered only if the Record Checking special feature is installed. When the terminal is polled by the CPU, the terminal sends a **(D)** followed by the contents of the buffer (starting with the first position of storage and ending with the EOB or EOT character). The contents of the buffer will not be printed during transmission since printing occurred as the buffer was loaded. When operating in local mode, each operation of the Bid key causes the contents of the buffer (keyed in while in local enter mode) to print out.

Reset Key. When operating in enter status and communicate mode, pressing the Reset key resets the buffer to its first storage position and shifts the terminal to standby status. Operating the Reset key while in enter local mode resets the buffer to its first storage position and removes the terminal from enter mode. If the Reset light (located to the right of key) is turned on because (1) the terminal received a **(C)** in response to an EOB signal, (2) an error was entered into the buffer while in enter status, or (3) an error was read from the buffer in a buffer print-out operation, operating the Reset key turns the light off.

Line Rtn (Return) Key (Special Feature). See Edit feature under Special Features, Model 2.

Line Type Key (Special Feature). See Edit feature under Special Features, Model 2.

Switches

The following switches are on a switch panel that is located at the right rear corner of the 2740 Model 2 table, Figures 17 and 21.

Header Switch (Special Feature). See Header Control under Special Features, Model 2.

Parity Switch. Operating this self-restoring switch resets the Parity light adjacent to the switch.

Test Switch. The Test switch is present only on terminals using certain IBM Leased or Shared Line Modems (special feature) to connect to the communications line (see IBM Line Adapters under Special Features, Model 2.)

Mod (Modem) Test. The switch is set to this position when running the Modem Test. The Modem test is used by the operator to determine (in most cases),

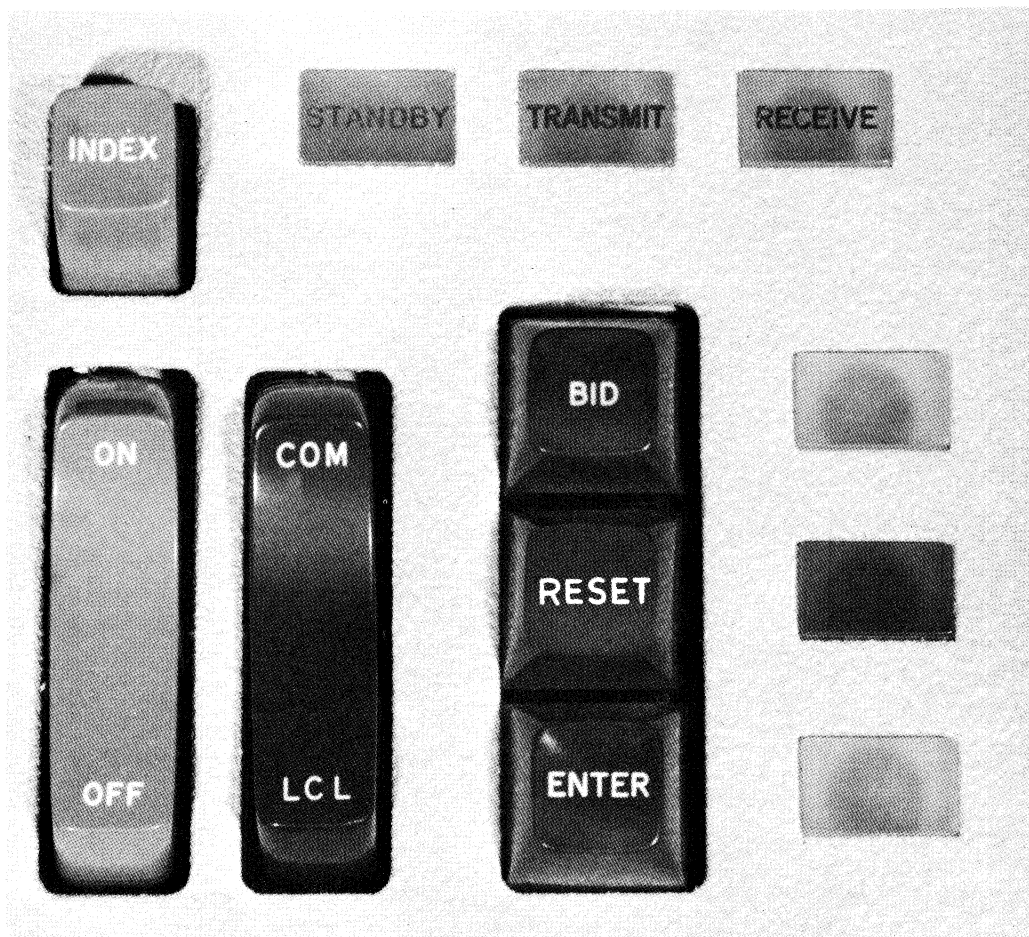

Figure 20. IBM 2740 Model 2 Operator Controls (Right Side of Keyboard)

whether the terminal or IBM Modem; or the receiving multiplexer, modem, or communications line is at fault when experiencing difficulty in communicating with the CPU. The Modem Test procedure is as follows:

- Set Local/Communicate switch to Communicate position.
- Press Enter key and type the test message. The test message should be of sufficient length to include all alphabetic and numeric characters.
- Press Bid key. Bid light turns on.
- Set Test switch to Mod (Modem) position.
- Transmit and Receive lights will blink indicating test is functioning properly. At completion of test, Receive light only remains on. If the Record Checking feature is installed, the Reset light will also be on at the completion of the test.

NOTE: If a failure occurs during the test, both the Transmit and Receive lights remain on. The Parity light will also be on if the type of error detected is a parity error.

- At completion of test, set Test switch to Off position.
- If the Reset light is on, set local/communicate switch to Local position and press Reset key.

Line Test. The Line position of the Test switch is used only at the request of the telephone company. The telephone company must ensure the user that this test will not interfere with the system's operation.

Indicator Lights

Standby Light. When on, this light (Figure 20) indicates the terminal has paper in the typewriter, is in communicate mode, and is ready to receive data.

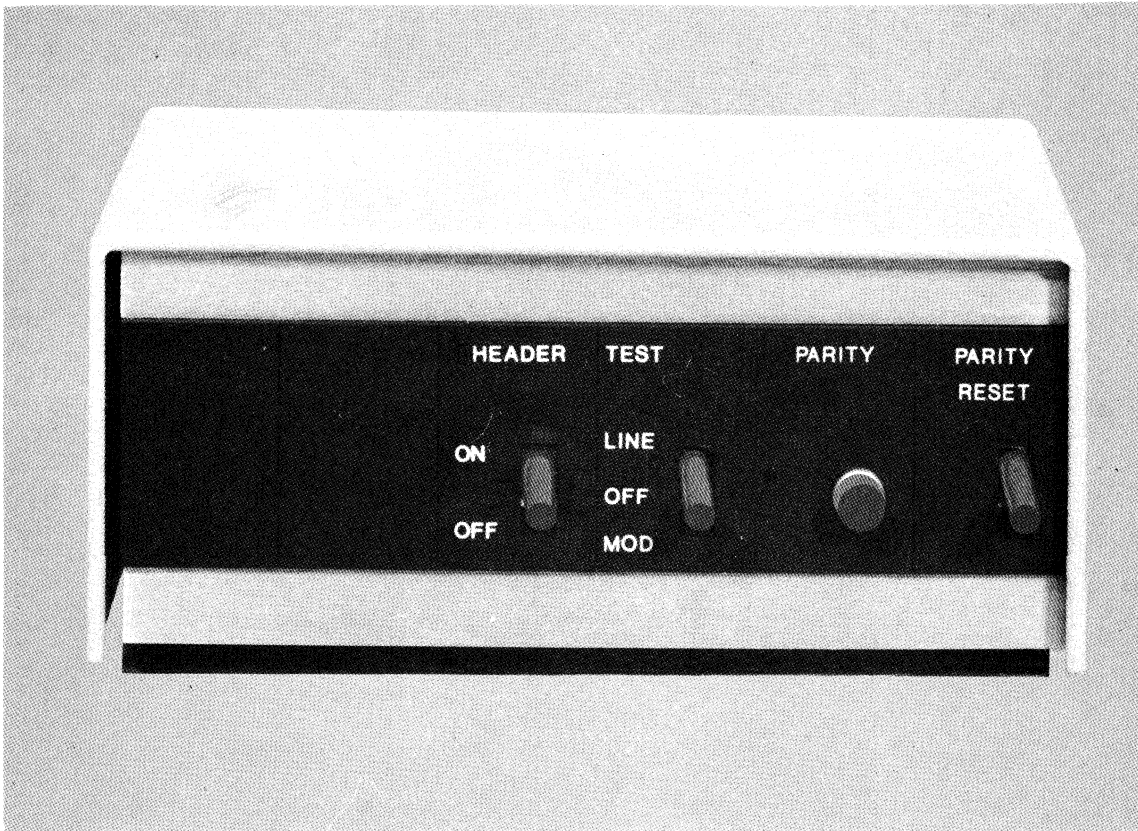

Figure 21. IBM 2740 Model 2 Switch Panel

Receive Light. The Receive light (Figure 20), when on, indicates the terminal is receiving and printing incoming data. If the Buffered Receive special feature is installed, the light is on while data is being received into the buffer and also during the buffer printout.

NOTE: The Receive light blinks each time a character is received.

Transmit Light. The Transmit light (Figure 20), when on, indicates the terminal is transmitting data from the buffer to the communications line.

NOTE: The Transmit light blinks each time a character is transmitted.

Enter Light. The Enter light (Figure 20), turns on whenever the Enter key is operated and remains on until the Bid key or Reset key is operated. When on, the Enter light indicates that information entered at the keyboard is being loaded into the buffer. The light will blink and the audible alarm will sound when each of the last eight characters is entered into the buffer, warning the operator that the buffer is nearly filled (120, 248, or 440 positions). The Enter light is adjacent to the Enter key.

Bid Light. The Bid light (Figure 20), turns on when the Bid key is operated indicating that the message in the buffer is ready to be transmitted whenever the terminal is polled by the CPU. The light turns off when the terminal is polled and transmission begins. The Bid light is adjacent to the Bid key.

Attn (Attention) Light. The Attention light (Figure 19), turns on and the audible alarm sounds momentarily if the terminal is addressed while in enter, local, or buffer-print status condition, or if the terminal typewriter is without paper. The Attention light turns off when the condition that caused it to turn on is corrected.

Platen Split Light (Special Feature). The Platen Split light (Figure 19), is on whenever the platen is in a split condition. This light may also glow (with less brilliance) when the standard friction feed platen is substituted for the split platen. See Split Friction-Feed Platen under Special Features, Model 2 in this section of the manual.

Parity Light. This light (Figure 21), turns on whenever the terminal receives or transmits a parity

error. The Parity light can be reset only by operating the Parity Reset switch located to the right of the light.

Reset Light. The Reset light (Figure 20), is turned on when any one of the following conditions exist:

Without Buffered Receive and Without Record Checking Special Features Installed

- Terminal receives parity error. Hyphen prints, Reset and Parity lights turn on, and printing of message continues. The Reset light is turned off automatically when the © EOT code is received at completion of message. Parity Reset switch turns Parity light off.
- Terminal receives incorrect-case code. Hyphen prints, Reset light turns on and printing of message continues. The Reset light is turned off automatically when © EOT code is received at completion of message.
- Printer overrun. Speed of characters received faster than printing speed. Reset light turns on at time of overrun, character(s) lost, however, printing of message continues. Reset light turned off automatically when © EOT code is received at completion of message.
- Parity error transmitted. Reset and Parity lights turn on when error is detected. Reset key turns Reset light off. Parity Reset switch turns Parity light off.
- Buffer parity error detected while in enter local or enter communicate mode. Keyboard locks and Reset light turns on. Reset key turns light off, restores the buffer, and terminates enter operation.
- Buffer parity error detected during printback after operating Bid key while in enter local mode. Reset light turns on, keyboard locks, but printout is completed. Reset key turns Reset light off, restores the buffer, and terminates the enter operation.

With Buffered Receive and Without Record Checking Special Features Installed

- Parity error detected during buffered-receive printout. Incorrect character prints, Reset light turns on, and printout continues. Reset key turns Reset light off.

- Overflow of receive buffer (garbled message printed). Reset light turns on at time of overflow and turns off automatically when © EOT code is received at completion of message.
- Parity error detected when transmitting. Reset and Parity lights turn on when error is detected. Reset key turns Reset light off and Parity Reset switch turns Parity light off.
- Buffer parity error detected while in enter local or enter communicate mode. Keyboard locks and Reset light turns on. Reset key turns Reset light off, restores the buffer, and terminates the enter operation.
- Buffer parity error detected during printback after pressing Bid key when in enter local mode. Reset light turns on, keyboard locks, but printout is completed. Reset key turns Reset light off, restores the buffer, and terminates the enter operation.

With Record Checking and Without Buffered Receive Special Features Installed

- Terminal receives a parity error in text (hyphen prints in place of error character). Reset and Parity lights turn on when error is detected and printing continues. Reset light turns off automatically when terminal receives © or © code at end of message. Parity Reset switch turns Parity light off.
- Terminal receives a © EOT answerback to a © LRC checking sequence. Reset light and audible alarm turn on and keyboard locks. Reset key turns Reset light off.
- Detection of buffer parity error when terminal is operating in enter local or enter communicate mode. Keyboard locks, Reset light turns on, and the Bid key function, while in communicate mode, is suspended. Reset key turns Reset light off, restores the buffer and terminates the enter operation.
- Detection of parity error during a local mode buffer printout operation. Reset light turns on, keyboard locks; however, printout is completed. Operating Reset key turns Reset light off, restores the buffer, and terminates the enter operation.

- Incorrect-case code received. Hyphen prints, Reset light turns on and remainder of message is printed. Reset light turns off automatically when Ⓒ EOT answerback is sent to CPU.
- Printer overrun. Speed of characters received faster than printing speed. Reset light turns on at time of overrun and character(s) lost; however, printing of message continues. Reset light turns off automatically when Ⓒ EOT answerback is transmitted to CPU at completion of message.
- Terminal transmits parity error. Reset and Parity lights turn on. Reset key turns Reset light off. Parity Reset switch turns Parity light off.
- No answerback to Ⓑ LRC sequence. Reset light turns on and remains on. Reset light can be turned off only by switching the local/communicate switch to local and operating the Reset key.

With Record Checking and With Buffered Receive Special Features Installed

- Parity error received in receive buffer. Reset light turns on and no printout occurs. Reset light turns off automatically when Ⓒ answerback is sent to CPU.
- Receive buffer overflowed. Reset light turns on and no printout occurs. Reset light turns off automatically when Ⓒ answerback is sent to CPU.
- Parity error detected during buffered receive

printout. Incorrect character is printed, Reset light turns on, and printout continues. Reset key turns Reset light off.

- Terminal receives Ⓒ answerback to Ⓑ LRC sequence. Reset light turns on and is reset by operating Reset key.
- Terminal transmits parity error. Reset and Parity lights turn on. Reset key turns Reset light off and Parity Reset switch turns Parity light off.
- No answerback to Ⓑ LRC sequence. Reset light turns on and remains on. Reset light can be turned off only by switching the Local/Communicate switch to local and operating the Reset key.
- Buffer parity error detected while operating in enter local or enter communicate mode. Reset light turns on and keyboard locks. Reset key turns Reset light off, restores the buffer, and terminates the enter operation.
- Detection of parity error during a local mode buffer printout operation. Reset light turns on, keyboard locks, however, printout is completed. Operating the Reset key turns the Reset light off, restores the buffer, and terminates the enter operation.
- With the Buffered Receive feature installed, only one message or message segment can be received at a time followed by an EOB/LRC sequence. A positive response to the EOB/LRC sequence followed by the receipt of a Ⓒ from the multiplexer causes a buffer printout to occur.

Local Mode

When operating in local mode, the information typed at the keyboard can also enter the buffer provided the Enter key is operated before typing. Pressing the Bid key after typing is completed causes the contents of the buffer to be printed. The information stored in the buffer can also be transmitted at a later time by switching the terminal to communicate mode and pressing the Bid key. In normal local-mode operation, no indicator lights are on; in local-enter mode, the Enter light is on. If a terminal is addressed or polled while operating in local mode, a (N) negative response is sent to the CPU. The Attention light and audible alarm are also turned on to alert the operator when the terminal is addressed.

Communicate Mode

When operating in communicate mode, pressing the Enter key unlocks the keyboard, turns the Enter light on, and enables the information typed at the keyboard to enter the buffer. The Enter light blinks and the audible alarm sounds as each of the last eight character positions of the buffer is filled to warn the operator that the buffer is nearly filled. The keyboard locks when the capacity of the buffer (120, 248, or 440 characters) is exceeded. After the message has been typed (or the buffer has been filled), transmission is initiated and the Enter light is turned off by operating the Bid key. The message stored in the buffer is transmitted after the Bid key is operated, when the terminal is polled by the CPU (see Figure 22). If addressed after the Bid key is oper-

ated, the terminal responds with a (N) negative response and turns on the Attention light and audible alarm. A (C) EOT signal is included automatically at the end of message transmission if the terminal does not have the Record Checking special feature installed. If the terminal is equipped with the Record Checking special feature, a (B) EOB signal is transmitted instead of the (C) EOT signal (see Figure 24). The (C) EOT signal is transmitted automatically after a (Y) positive response is received from the CPU.

If the CPU responds to checking with a (d), the terminal shifts to receive status in order to receive the incoming message (see Figure 24). A (N) negative response to checking from the CPU causes the terminal to shift back to transmit status and to retransmit the contents of the buffer. A (C) EOT response from the CPU will shift the terminal to standby status and turn on the Reset light, Standby light, and audible alarm. The (C) response from the CPU is received only after a predetermined number of retransmissions have been unsuccessful. The number of retransmissions is determined by the CPU program.

When operating in communicate mode, the typewriter keyboard is locked under the following conditions:

- If terminal is in communicate mode, but not in enter status.
- When a buffer VRC error is detected.

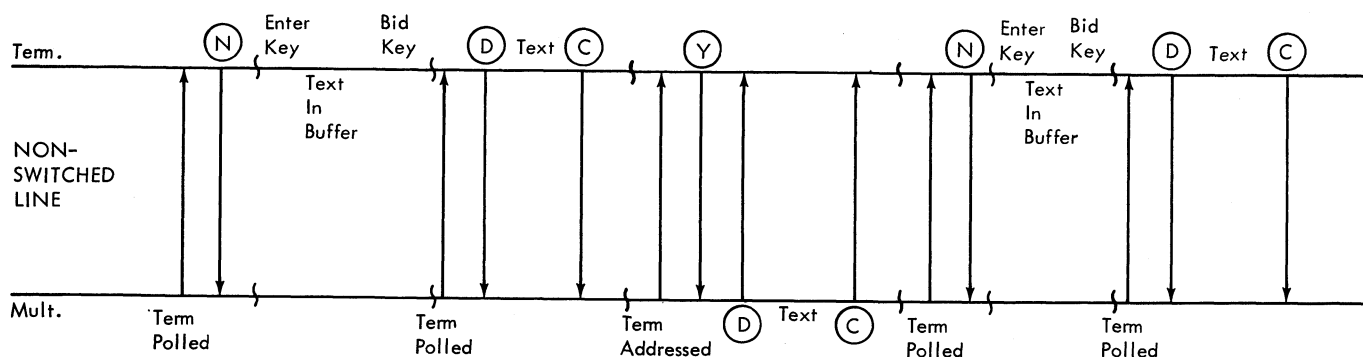

Figure 22. Addressing and Polling Operation (No Special Features)

- When the buffer is filled while in Enter mode.
- During a carrier-return or tab operation.
- If terminal is in buffer print mode.

To return the carrier to the left margin, when the keyboard is locked; shift to local mode, and press the Reset and Return keys.

Station Control (Multiplexer Addressing and Polling)

Station Control provides the terminal with the ability to be addressed indicating "Prepare to receive", or to be polled (a signal indicating "Prepare to send") from the multiplexer (Figures 22, 23, 24, and 25).

NOTE: Each 2740 master terminal (either group or all call), requires its own local loop when using a 4-wire IBM leased or shared line IBM Line Adapter. A local loop is considered to be the communication line between the common-carrier connecting office and the customer's 2740 terminal installation. This local loop cannot be shared by other 2740 terminals. Subordinate 2740 terminals will fail to print the first text character following an EOB/LRC sequence if they are on the same local loop as the master terminal.

All communication in the multiplexer operation is centralized both to and from the multiplexer to the terminal. The multiplexer does all the necessary polling and addressing. Anytime there is no transmission from a terminal (in transmit status) for a fifteen second time period, a time-out occurs and the terminal shifts to standby status.

Each terminal is assigned a single character identification code (either alphabetic A-Z, numeric 0-9, or any of five additional characters). The five additional characters are: @, -, \$, ., and &. This identification character is specified by the customer and wired by IBM personnel at installation time.

Polling

The polling sequence is an identification code followed by the Space character. The terminal responds with a (N) if it is not ready to transmit data and a (D) followed by text if it is ready to transmit (Figures 22 and 24).

Addressing

Each 2740 Model 2 terminal can be addressed by three different means: an Individual address, a Group address, or an All-Call address. The Individual address consists of an identification code, selected at time of installation, followed by the Space character. Only the addressed terminal responds to an individual address.

A group address consists of the group identification code, selected at time of installation is followed by the Space character. This character cannot be one that is used as an individual address. The group address is used for addressing only and allows all terminals in the group (wired for the particular identification code) to receive the message transmitted from the CPU. Only one terminal (designated Master terminal) of the group responds to the group addressing sequence.

The All-Call address is the slash (/) character followed by the Space character. The All-Call Address enables all terminals on the line (in Standby status) to accept the transmitted message. Only one terminal (Master terminal) responds for the group. The Group or All-Call Master terminal is designated by the user at the time of installation and wired by an IBM Customer Engineer. If the addressed terminal is not ready to receive data, it responds with a (N), or if ready, with a (Y) (Figures 22, 23, and 25). An All-Call or Group Master terminal responds for the group with (N) or (Y), depending upon the condition.

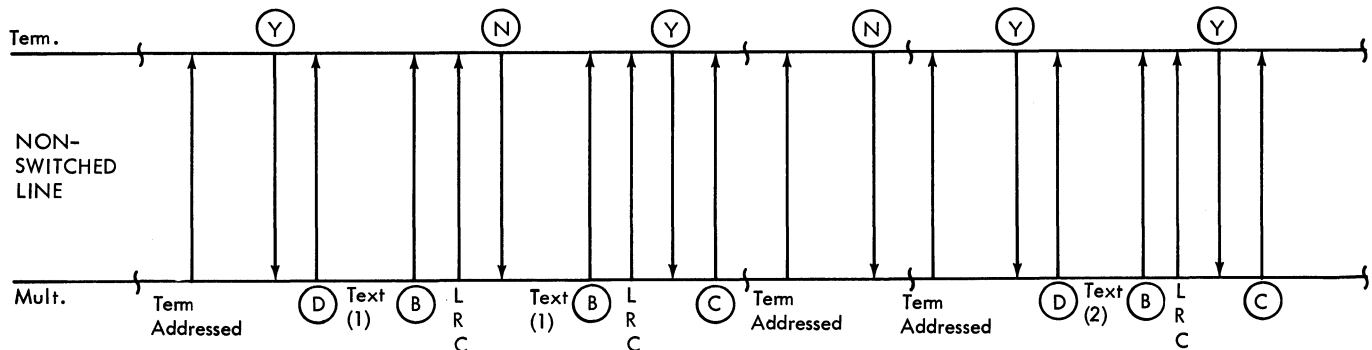

Figure 23. Addressing Operation (With Record Checking Special Feature Only)

Figure 24. Polling Operation (With Record Checking Special Feature Only)

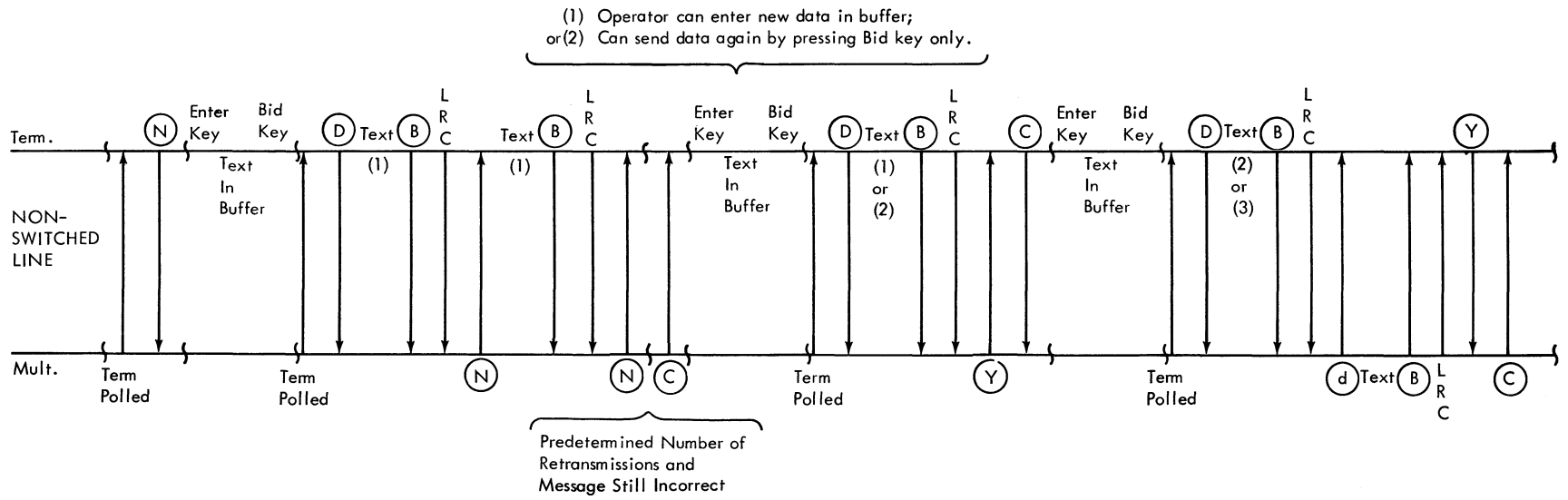
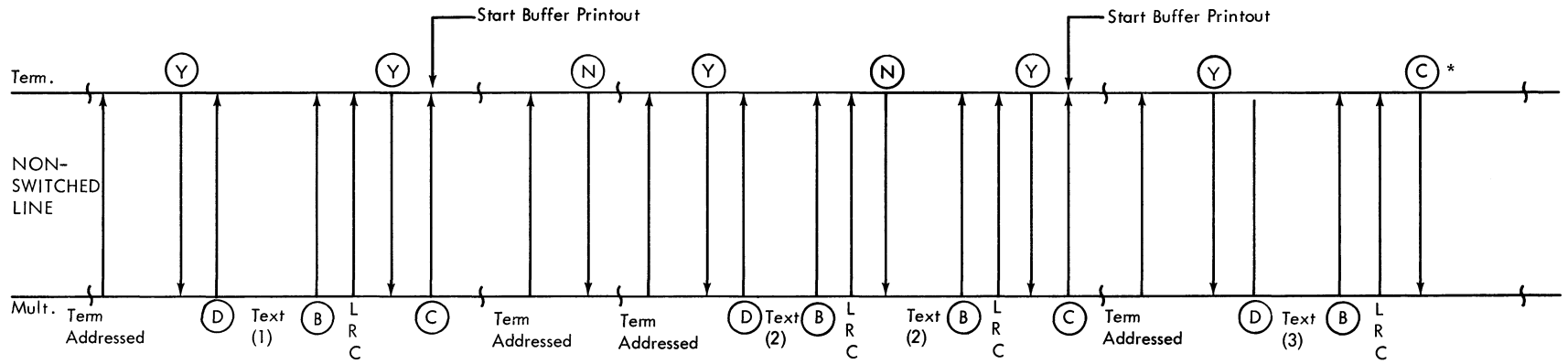

Figure 25. Addressing Operation (With Record Checking and Buffered Receive Features Installed)



* The (C) is a negative answerback in this case. The contents of the buffer will not be printed.

Buffer Expansion

The buffer is also available in 248- and 440- position sizes. The increase in buffer capacity permits a longer message to be transmitted at any one time.

Record Checking

The Record Checking feature is comprised of two parts: VRC (vertical redundancy check) and LRC (longitudinal redundancy check). A VRC (odd parity) check is made on each character as it is received at the receiving terminal. An error received is printed as a dash (-) character (if Buffered Receive feature is not installed) and the Parity and Reset lights turn on. During transmission, each terminal (transmitting and receiving) records the bit structure of each character. The LRC counter at each terminal is started by the transmission of the **(D)** signal which indicates the start of a message. All character bits are recorded at both terminals until the **(B)** EOB signal is transmitted. The **(B)** signal causes the contents of the transmitting LRC counter to be sent to the receiving terminal. At the receiving terminal the two LRC characters are compared. If the two LRC characters agree, and there is no VRC parity error (or any other error such as incorrect case, overrun, etc.), a positive answer **(Y)** is sent to the transmitting terminal.

OperationTransmitting Terminal

When the operator has completed keying a message, made any necessary corrections and pressed the Bid key, the terminal is shifted to lower case (the shift code is stored, if necessary), and a **(B)** EOB code is stored in the buffer. The **(D)** followed by the contents of the buffer (starting with the first position of storage and ending with the **(B)** LRC character), is transmitted when the terminal is polled by the CPU (Figure 24). The contents of the buffer will not print while the data is being transmitted.

After transmission is completed and the message is acknowledged by the CPU (**(Y)** only), the Transmit light turns off and the Standby light turns on. If the CPU acknowledgment indicated an error condition **(N)**, the terminal retransmits the message automatically (Figure 24). The message continues to be retransmitted until a positive response **(Y)**, a **(d)**,

or a **(C)** EOT response is received from the CPU. A **(C)** EOT response indicates the CPU has not received the message correctly and continues to be retransmitted until a positive response **(Y)**, a **(d)**, or a **(C)** EOT response is received from the CPU. A **(C)** EOT response indicates the CPU has not received the message correctly and wants to terminate the transmission. Upon receipt of the **(C)** code the terminal switches to Standby status (with the Standby light, Reset light, and audible alarm turned on, and the keyboard locked), to indicate to the operator that the message was in error. The message can be retransmitted without rekeying, by pressing the Reset key and then the Bid key. The message will be retransmitted when the terminal is polled by the CPU.

If the message is received correctly, the Transmit light turns off automatically when the positive acknowledgment **(Y)** or **(d)** is received from the CPU (Figure 24). When a **(Y)** response is received, the terminal sends a **(C)** EOT code to the CPU and switches to Standby status (Standby light on). When a **(d)** response is received, the terminal switches to Receive status automatically (Receive light on) to receive the incoming message from the CPU. If any character other than **(C)**, **(Y)**, or **(d)** is received as a response to the **(B)** LRC sequence, it is treated as a **(N)** and the message is retransmitted.

Receiving Terminal

After receiving the **(B)** code, the receiving terminal compares the next character received (LRC character) with its accumulated LRC character. If they do not compare, if a VRC error occurred previously, or if any other error (incorrect case, buffer overflow, etc.) occurred, the negative response could be a **(N)** or **(C)** depending on the type of error (Figures 23 and 25). An error message is never printed at the terminal if the Buffered Receive feature is installed. If the Buffered Receive feature is not installed, the message is printed as it is received. Characters of incorrect parity (VRC check) or of incorrect case print as dashes (-). If a **(N)** is sent to the multiplexer, a dash prints at the end of the message.

When the message is received correctly, the terminal sends a **(Y)** code to the CPU. With the Buffered Receive feature installed, the CPU must respond with a **(C)** code to initiate printing of the correctly received message stored in the buffer of

the terminal. Without the Buffered Receive feature installed, the CPU may respond to the (Y) with another block of text, or a (C) EOT code.

When the Buffered Receive feature is installed, only single blocks of data can be transmitted by the CPU. If multiple blocks of data are transmitted, only the last correctly received message preceding the (C) code will print. This condition is not detectable at the CPU and results in lost message blocks at the receiving terminal.

NOTE: The use of the Record Checking and Buffered Receive special features is recommended when the Document Insertion special feature is installed. The use of these two features prevents the printout of incorrectly received messages on ledger cards that are manually inserted in the Document Insertion device (see Buffered Receive and Document Insertion special features in this section of the manual).

Buffered Receive

This feature permits the IBM 2740 Model 2 terminal to receive data into the buffer from the communications line. The printout of the buffer takes place after the message (C) EOT signal is received from the CPU, thereby reducing the time that the transmission line is in use (Figure 25). The Receive light is on and the keyboard is locked during the buffered-receive printout operation. If the terminal is addressed during the printout operation, it responds with a (N) signal. The terminal switches from receive status to standby status after the buffer printout has been completed. Idle characters are not required after function codes (CR, Tab, and Index), since the Buffered Receive feature allows completion before continuing the printout. This reduces the number of transmitted characters. The length of transmission cannot exceed buffer capacity (120, 248, or 440 positions). If the Record Checking feature is installed and a buffer overflow occurs, the Reset light turns on, no printout occurs, and a (C) EOT code is sent to the CPU. If a buffer overflow occurs and the Record Checking feature is not installed, a garbled message will print out.

With this feature and the Record Checking feature installed, only single blocks of data can be transmitted by the CPU. If multiple blocks of data are transmitted, only the last correctly received message preceding the (C) code will print. This condition is not detectable at the CPU and results in lost message blocks at the receiving terminal.

Telegraph Line Adapter

This feature provides an adapter that enables the

IBM 2740 Model 2 to be used with a 75-bps leased private-line telegraph service. With this feature, the terminal can operate over leased common-carrier or equivalent privately owned 75-bps telegraph channels. When using these facilities, non-code-sensitive regenerators must be used. The channel must be able to operate at 75 bps with the 9-bit-per-character code, and must be terminated in a 62.5-ma neutral dc loop at the terminal. Transmission rate is 8.33 characters per second (cps).

Speed Base--600 bps

This feature provides for operating over leased common-carrier private-line telephone service or equivalent privately owned facilities at 600 bps (66.7 cps). The Buffered Receive feature is a prerequisite.

Header Control

This feature allocates up to 28 positions of the buffer for storing repetitive header information. Starting with position 1, increments of four positions (up to 28 maximum) can be specified at the time of ordering. With the Header switch in the OFF position (switch located at right rear corner of typewriter table), data typed at the keyboard can be entered into the header area of the buffer (Enter key operated). This data is available every time the buffer reads out to the line. Changes in data in the header area of the buffer must be made by retyping the entire area. Once header data has been entered, turning the Header switch to the ON position allows subsequent data entered to automatically start at the end of the header area of the buffer. Transmission will be from the beginning of the header area to the end of information stored in the buffer. All positions of the header area must be filled with characters and/or spaces. If the terminal power is turned off, the buffer information will be lost. Data keyed into the buffer (including the header area) can be printed out for verification by entering the data while in local-enter mode (with Header switch in OFF position) and pressing the Bid key after all data has been entered.

NOTE: If the Buffered Receive feature is installed, the positions used for header control are not available to receive data from the line when the Header switch is set to the ON position.

Edit

The Edit feature simplifies the method of correcting typing errors entered into the buffer; however, the

backspace-retype and restart-retype methods of correction (described under Typing Error Correction Procedure) may still be used. The Edit feature is controlled by the following keys:

Line Return Key. This key is operative only when the terminal is in the enter-local or enter-communicate mode. Pressing the Line Return key immediately following the operation of the Line Type Key or keyboard operation causes the buffer to back up and erase all characters up to and including the first character of the present line.

Line Type Key. The Line Type key is operative only in enter-local or enter-communicate mode. Operating this key immediately after the buffer is restored to position 1 by the Enter key causes the buffer to print out to, and perform, the next carrier return stored in the buffer. Subsequent lines may be typed out by repeated operation of the Line Type key, which becomes inoperative after typing a character or reaching the character where the Enter key was operated.

Enter Key. Pressing this key while in the enter mode causes the buffer address to be reset to the first position and the terminal to remain in enter mode.

Edit Error-Correction Routines

If an error occurs in the present line of typing, the correction procedure is as follows:

1. Press CR/LF key (moves print element to left margin and next line).
2. Press Line Return key to back up the buffer to the beginning of the line.
3. Rekey the entire line.

If the error is not in the present line of typing, the correction procedure is as follows:

1. Press CR/LF key (moves print element to left margin and next line).
2. Press Enter key (restores buffer to position 1). This is the second operation of the Enter key since this key was operated before typing was started.
3. Press Line Type key, advance the buffer line-by-line (by repeated operation of the Line Type key) until the end of the line to be corrected is reached.
4. Press Line Return key.
5. Retype the line in error and all succeeding lines of the message.

The stored information can be verified by switching to local mode and pressing the Bid key or by repeating the Line Type key operation. This causes the contents of the buffer to be printed. If the message is correct, switch to communicate mode and press the Bid key. Transmission will occur when the terminal is polled.

Split Friction-Feed Platen

A Split Friction-Feed Platen is available to further enhance the forms-handling capability of the IBM 2740 Model 2 terminal. This feature can only be installed at the plant and must be specified with the order. However, the operator can interchange the split platen with a standard friction-feed platen. The two sections of the platen may be manually disengaged by pulling out on the left platen knob, and will remain disengaged until this knob is pushed in. When the platen is split (disengaged), only the right portion will be indexed by manually operating the Index key, the platen knobs, or by receipt of line feed or new line code from the CPU. When the platen is not split (engaged), both sections are indexed normally. The platen is split so that 5-1/2 inches of the printing line is available on the left portion. The print positions that would print directly on the split in the platen should not be used since they may not be legible. For a 10-pitch machine, this could be the 56th or 57th character. For a 12-pitch machine, this could be the 67th or 68th character.

The Platen Split indicator light (Figure 19), is on whenever the platen is in a split condition. This light may also glow (with less brilliance) when the standard friction feed platen is substituted for the split platen. When the Document Insertion feature is operated, the keyboard will lock if the platen is split. The keyboard will unlock when the platen is restored to normal.

NOTE: The Document Insertion feature is a prerequisite when ordering the Split Friction-Feed Platen feature.

Document Insertion

The Document Insertion feature (Figure 26) enables the operator to easily insert and position individual forms to receive all or a portion of the printed output. A typical application might be printing on a continuous-form journal and simultaneously posting on ledger cards that are manually inserted by the operator. If the Split Platen feature is installed and the Document Insertion feature is not in use, the entire writing line of the typewriter is available

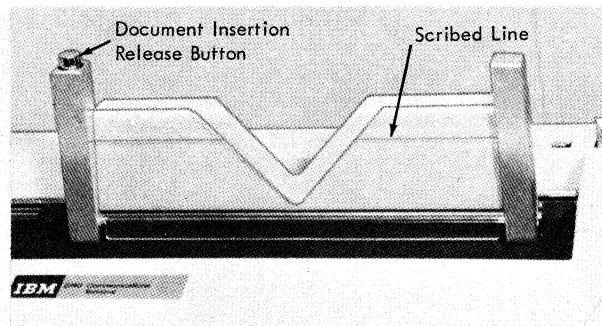

A

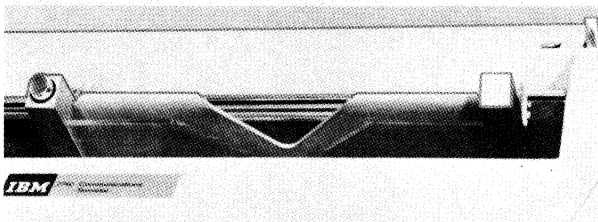

B

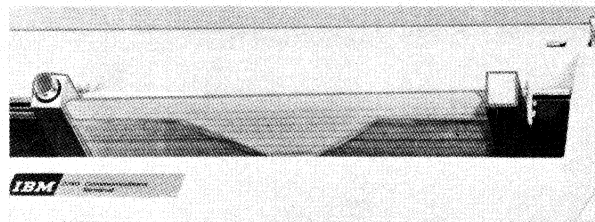

C

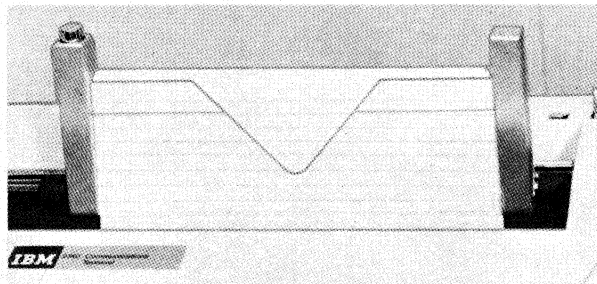

D

Figure 26. Document Insertion Feature

for printing if the operator replaces the split platen with a standard friction-feed platen (see Split Friction-Feed Platen).

NOTE: Pin-feed platens cannot be used when the Document Insertion feature is installed.

When either of the Document Insertion features are used (6 inch or 7-3/8 inch) the left margin stop must be positioned at least 2.3 inches to the left of the first character to be printed on the document. This allows the print element and carrier mechanism to clear the document chute when the document insertion device is tilted forward to insert the document. Margins are set by pushing the Margin Stop lever to the rear and moving it either to the left or right to the desired location. Therefore, the initial operation of a line-message

printout must begin with an HT (Horizontal Tab) code to move the carrier a minimum of 23 print positions to the right. The same line-message printout should conclude with an NL (New Line, Carrier Return and Line Feed) code to return the print element to its extreme left position. The following versions of the Document Insertion feature are available:

Feature Number 3401. This version of the Document Insertion feature accepts cards 6 inches wide and permits the operator to position them so that the left edge of the card is 2-1/2 inches to the right of the first print position. If a 10 or 12 cpi (character-per-inch) print element is used, 25 (10 cpi) or 30 (12 cpi) characters, respectively, may be

printed before printing on the ledger card occurs. Print-position 26 (10 cpi) or 31 (12 cpi) cannot be used, and position 27 (10 cpi) or 32 (12 cpi) will print on the ledger card.

Feature Number 3402. This version of the Document Insertion feature accepts cards 7 3/8 inches wide and permits the operator to position them so that print-position 57 (10 cpi) or print-position 68 (12 cpi) is the first position to print on the card. Print-position 56 (10 cpi) or 67 (12 cpi) cannot be used.

Ledger-Card Stock

The ledger card should be of single-part, 90- to 120 pound stock (IBM card stock meets these specifications).

NOTE: The grain of the paper stock used should be in the same direction as the printing on the document (horizontal). The length of the card should be 5 inches.

The location of the first printable line on the document depends upon the version of Document Insertion feature being used. The last printable line is 1.0 inches from the bottom of the card regardless of which feature is used.

Operation

The Document Insertion feature provides a means of inserting ledger cards in front of the typewriter platen without using the platen knobs (Figure 26). To insert the ledger card, push down on the Release button (Figure 26, Part A) and simultaneously pull the post toward the front of the terminal (Part B). When the feature is tilted forward, the feed rolls are open and the card can be inserted (Part C). A pressure arm pushes the card against the left card guide while the feed rolls are open.

After the card is inserted, the feature can be moved toward the rear of the machine. This action requires very little effort as the device is spring loaded. The card can still be moved at this time, and can now be positioned for printing (see Document Design). The feature is locked in position by again pushing down on the Release button. The spring-loaded mechanism returns the feature to its home position, and the card is held securely in place and is ready to receive the printed data. The card is removed by repeating the Release button and tilt-forward action. An interlock locks the keyboard whenever the feed rolls are open.

Document Design

When designing the format of documents to be used in the Document Insertion device, one must consider the location of the operator print-line indicators and the distance between the indicators and their corresponding lines of printing on the docu-

ment. The print-line indicators can be either numerals or alphabetic characters (6-inch), or lines identified by numerals or alphabetic characters (7-3/8 inch). The print-line indicators are printed commercially on the document and are a part of the document design specifications provided by the customer.

Document Alignment (6 Inch Width)

When using 6 inch documents, the first operator print-line indicator (upper A in Figure 27) should be printed 1/4 inch in from the right-hand edge and a minimum of 9/16 inch from the top of the document. Succeeding print-line indicators B, C, D, etc., are spaced 6 to the inch.

When the document is inserted and the first print-line indicator (A) is aligned between the two red scribed lines on the document chute, the bottom of the first line of printing will be 1.3 inches below the centerline of the two scribed lines (Figure 27). Each succeeding line of printing will be 1.3 inches below the centerline of the corresponding print-line indicator. The vertical spacing of the print-line indicators should be 6 lines per inch.

Additional numerals or alphabetic characters can be printed on either the right or left edge of the document (when it is commercially printed) to identify the lines of printing. These numerals or alphabetic characters are used when periodic posting is done on the document. The operator can quickly identify the next line to be printed and can insert and position the document accordingly. That is, if line D is the next line to be printed, the document is positioned so that operator print-line indicator D is centered between the two red scribed lines on the document chute. The identifying numerals or alphabetic characters are vertically spaced 6 per inch.

Document Alignment (7 3/8 Inch Width)

When using a 7-3/8 inch document, a line should be printed that extends in from the right edge of the document a minimum of 1/4-inch and that this line be a minimum of 7/16-inch from the top of the document (Figure 28). Succeeding lines are vertically spaced 6 lines per inch.

When document is inserted and the first print-line indicator (1) is aligned with the red scribed line on the document chute, the bottom of the first line of printing on the document will be 2.28 inches below the indicator line (Figure 28). The bottom of each succeeding line of printing will be 2.28 inches below the corresponding print-line indicator.

Additional numbers or alphabetic characters can be printed on either the right or left edge of the document (when commercially printed) to identify the lines of printing. These numerals or alphabetic characters are used when periodic posting

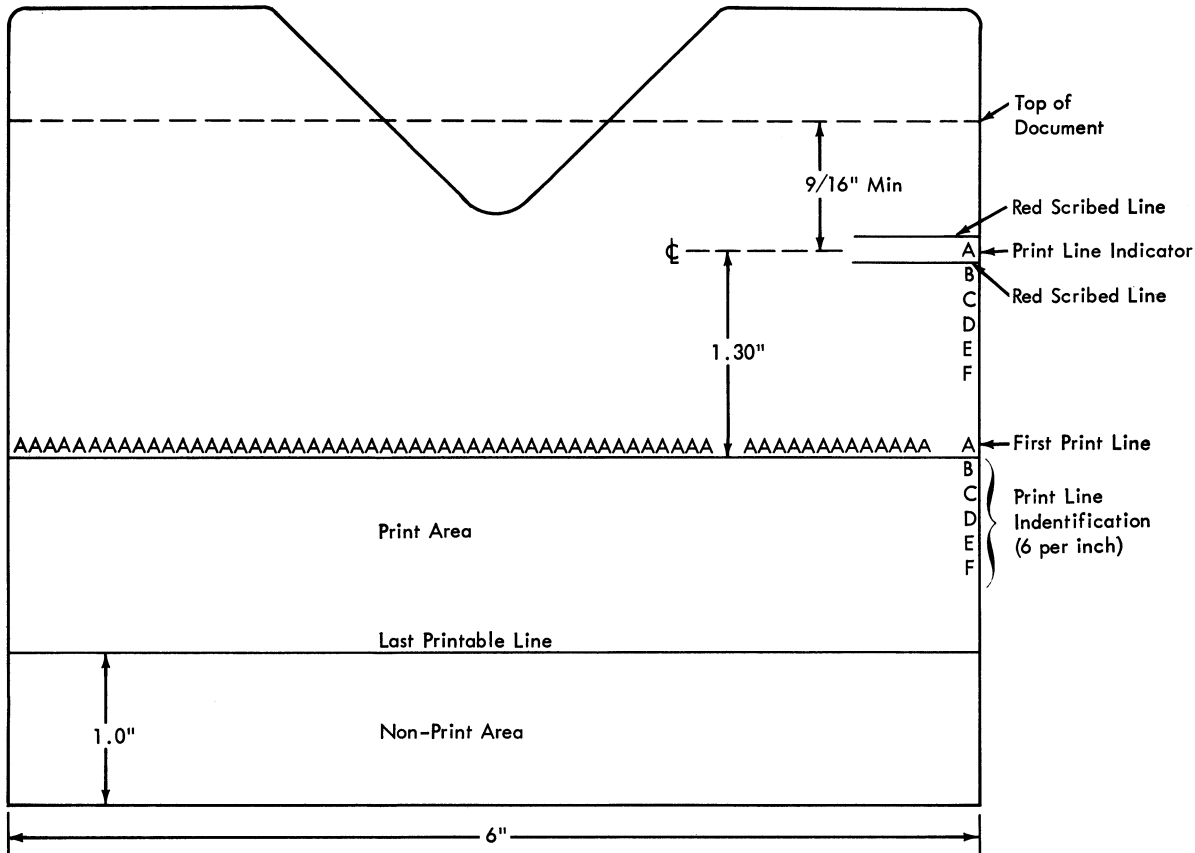

Note: Not Drawn to Scale

Figure 27. Document Alignment (Six Inch Document)

is done on the document. The operator can quickly identify the next line to be printed and can insert and position the document accordingly. That is, if line 4 is the next line to be printed, the document is positioned so that the number 4 print-line indicator is in alignment with the red scribed line on the document chute. The identifying numerals or alphabetic characters are spaced 6 per inch.

Paper Guide, Tear Bar, and Roll Paper Holder

This accessory provides for mounting rolls of continuous forms or paper on the back of the typewriter. It also serves as a guide for the paper after printing has been completed. A tear bar provides for tearing off printed matter.

Pin-Feed Platens

Pin-feed platens are available in the following inch sizes for the IBM 2740 Communication Terminal Model 2 Selectric Typewriter. Any one of these platens may be ordered in place of the standard friction-feed platen.

NOTE: Pin-Feed platens cannot be used when the Document Insertion special feature is installed.

<u>Over-all Forms Width</u>	<u>Hole-to-Hole Width</u>	<u>Writing Line</u>
5 3/4	5 1/4	4 3/4
6 1/2	6	5 1/2
8	7 1/2	7
8 1/2	8	7 1/2
9 1/2	9	8 1/2
9 7/8	9 3/8	8 7/8
10 3/8	9 7/8	9 3/8
10 1/2	10	9 1/2
10 5/8	10 1/8	9 5/8
11 3/4	11 1/4	10 3/4
12	11 1/2	11
13 5/8	13 1/8	12 5/8

IBM Line Adapter (Limited-Distance Type 1)

This feature permits the customer to attach an IBM 2740 Terminal Model 2 to customer-installed communications line or leased common-carrier private

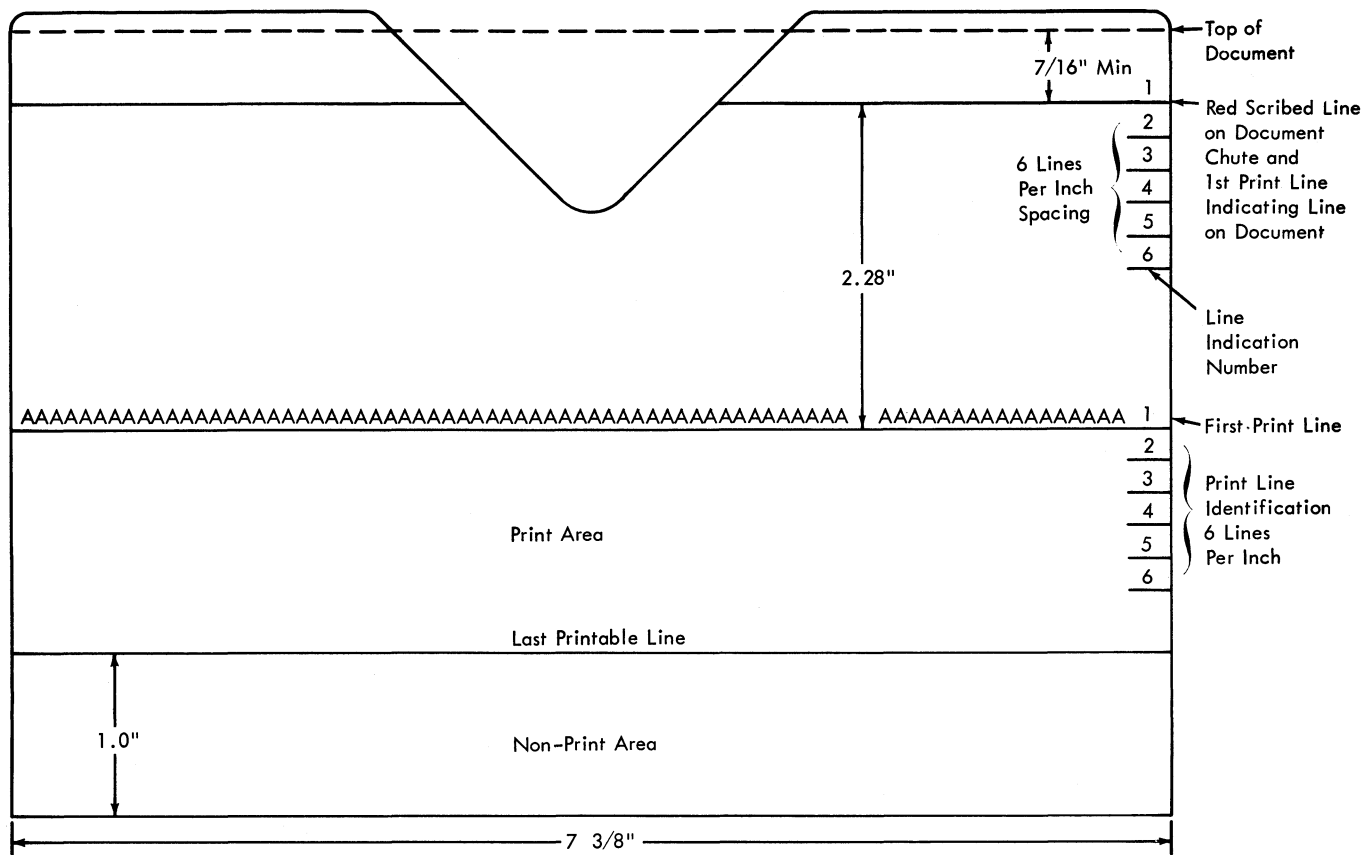

Note: Not Drawn to Scale

Figure 28. Document Alignment (Seven and Three Eights Inch Document)

line channels. The line adapter feature (installed within the 2740) provides the necessary signal modulation and demodulation for transmission on two-wire or four-wire communications lines up to 4.75 miles in length with a single 2740 attached. Two versions of this line adapter are available: Type 1A for two-wire systems, and Type 1B for four-wire systems.

IBM Line Adapter (Limited-Distance Type 2)

This permits the customer to attach an IBM 2740 Terminal Model 2 to customer-installed communications lines or leased common-carrier private line channels. The line adapter feature (installed within the 2740) provides the necessary signal modulation and demodulation for transmission on two-wire communications lines up to 8.0 miles in length.

IBM Line Adapter (Leased Line)

This feature permits the customer to attach an IBM 2740 Terminal Model 2 to a leased common-carrier private line or equivalent privately owned facility. This line adapter feature (installed within the 2740) provides the necessary signal modulation and demodulation for transmission on a communications line without length restriction.

IBM Line Adapter (Shared Line)

This feature permits the customer to attach an IBM 2740 Terminal Model 2 to one of four subchannels which can be obtained from either the customer's privately owned or leased common-carrier telephone-grade communications facilities. This line adapter also provides the necessary signal modulation and de-

modulation required for data communications. With this feature, one telephone line can provide up to four separate paths for simultaneous data transmission. This line adapter is available for operation on either two-wire or four-wire communications facilities.

NOTE: For additional information on the use of IBM line adapters, see Planning and Installation of a Data Communications System Using IBM Line Adapters, Form A24-3435.

TIMING CONSIDERATIONS, MODEL 2

The timing considerations for the IBM 2740 Model 2, with the following exceptions, are the same as those described for Model 1 in this manual.

Typewriter Delay Conditions

The typewriter delay formula (Model 1) reflects the operation of the typewriter at its maximum speed of 14.8 characters per second. If the Speed Base (600 bps) special feature is installed on the Model 2, transmission speed is 66.7 characters per second. This, however, would have no effect on the formula,

since the Speed Base feature requires the Buffered Receive feature as a prerequisite.

To compute the number of idle codes required when operating at 8.33 characters per second (Telegraph Line Adapter special feature installed), divide the results of N in the formula as shown by 1.7, and round off to the next whole number. If the Buffered Receive special feature is installed, idle characters are not required after function codes (NL, HT, and LF), as the receive buffer allows the function to be completed before continuing the printout.

IBM 2740 Model 2 Data-Handling Capability

The timing formulas for addressing, polling and checking, as shown for Model 1, use a 67.5 milliseconds-per-character timing factor. This factor is based on a 14.8 character-per-second operation. To calculate the addressing, polling, and checking time for 66.7 character-per-second operation, use 15 milliseconds instead of 67.5 milliseconds. To calculate the addressing, polling, and checking time for an 8.33 character-per-second operation, use 120 milliseconds instead of 67.5 milliseconds.

The following is a listing of the communications terms used in this manual. For a complete listing of communications terms refer to the manual IBM Data Processing Techniques, Data Communications Glossary, Form C20-1666.

Addressing. The sending by a terminal (or multiplexer) of a series of characters that specify the remote terminal (or terminals) to receive the succeeding message.

All Call. A method by which a transmitting terminal or CPU sends a message that is received by all terminals on the communications line.

Bit. Contraction of "binary digit," the smallest unit of information in a binary system. A bit may be either a one or a zero.

Bit Rate. The speed at which bits are transmitted, usually expressed in bits-per-second.

Buffer. A storage device used to compensate for a difference in rate of flow data, or time of occurrence of events, when transmitting data from one device to another.

Contention. A situation that exists on a communications line when more than one terminal attempts to use the line at the same time. Line control prevents contention.

Data Set. A modulation/demodulation device designed to provide compatibility between input/output equipment and communications facilities.

Demodulation. The conversion of frequency signals from a communications line to signals for a business machine.

Half-Duplex. A communication channel capable of transmitting in both directions, but in only one direction at a time.

Line Control. The system used by either the operator or the machine controlling a communication system to positively determine the transmit-receive relations of the various terminals.

Master Terminal. A remote terminal on a multipoint line which is designated to perform all

addressing or checking answer-back functions for a group of terminals.

Modulation. The conversion of signals from a business machine to frequency signals for transmission over communications lines.

Multiplexer. A device for collecting the input from many communications lines and transferring it to the CPU; also, for accepting information from the CPU and transferring it to one of many communications lines without forcing the CPU's timing to match that of the connected terminal(s).

Non-Switched Line. A communications line devoted to one user, not part of a switched network; a leased private line or privately owned line.

On Line. Associated with a processor either directly or through a transmission control unit. The physical connection can be accomplished by either multiwire cable or a communications line.

Point-to-Point Transmission. Transmission of data directly between two points with no intermediate terminal.

Polling. The sending by a terminal (or multiplexer) of a series of characters that allows a particular remote terminal to transmit a message.

Subordinate Terminal. A remote terminal on a multipoint line which has no answer-back capability and depends on a master terminal to provide all answer-back functions, in addressing or checking.

Switched Line. A communications line used by more than one customer; part of a switched network.

Terminal. A machine or group of machines capable of generating and/or receiving signals transmitted and/or received from a communications line.

Time-Out. The time interval allotted for certain operations before system operation is interrupted and must be restarted.

Transmission Control Unit. A communications multiplexer.



APPENDIX

This Appendix includes the code charts, keyboards,
and graphics involved for the three types of codes

used with the 2740 Communication Terminal.

LOWER CASE	BIT VALUE							UPPER CASE
	B	A	C	8	4	2	1	
.	B		C			2		.
i	B	A	C		4		1	:
/	B	A			4	2	1	/
!	B		C		4			"
=	B	A				2		o
-	B	A		8		2	1	+
/	B	A		8				-
1/3							1	?
2						2		±/£
3			C			2	1	@
4				8				#
5					4			\$
6			C		4	2		%
7			C		4		1	¢
8					4	2	1	&
9				8		2	1	*
0			C	8			1	(
a	B		C		4	2	1)
b		A	C	8		2	1	A
c		A	C		4	2	1	B
d		A			4		1	C
e		A	C		4			D
f	B	A	C			2	1	E
g	B	A					1	F
h		A		8			1	G
i	B				4	2		H
j	B	A	C					I
k		A			4	2		J
l		A	C	8				K
m	B		C				1	L
n		A	C			2		M
o	B		C	8				N
p	B	A			4			O
q	B	A	C		4	2		P
r	B				4		1	Q
s	B			8			1	R
t		A						S
u		A				2	1	T
v	B					2	1	U
w	B		C	8		2	1	V
x		A	C				1	W
y	B	A	C	8			1	X
z			C	8		2		Y
								Z

THE CODES BELOW ARE NOT PRINTABLE

FUNCTION CODES	MEANING	
PN	C 8 4	Punch On
BY	A 8 4	Bypass
RES	B 8 4	Restore
PF	B A C 8 4	Punch Off
RS	8 4 1	Reader Stop
LF	A C 8 4 1	Line Feed
NL	B C 8 4 1	New Line (Carrier Return and Line Feed)
HT	B A 8 4 1	Horizontal Tab
UC	8 4 2	Upper Case
EOB	A C 8 4 2	End of Block
BS	B C 8 4 2	Backspace
LC	B A 8 4 2	Lower Case
EOT	C 8 4 2 1	End of Transmission
PRE	A 8 4 2 1	Prefix
IL	B 8 4 2 1	Idle
DEL	B A C 8 4 2 1	Delete
Space	C	Space

Code Chart (Standard Selectric Typewriter Print Element)

NOTE: Available only on an RPQ (Request Price Quotation) basis for Model 2.

LOWER CASE CHARACTER SET				Bit Value							UPPER CASE CHARACTER SET			
Std.	A	H	Typ.	B	A	C	8	4	2	1	Std.	A	H	Typ.
.				B	A		8		2	1	.			
\$				B		C	8		2	1	!			:
'					A	C	8		2	1	'			:
#	=						8		2	1	±	±±		"
@	'	1/2			A						¢	Δ		1/4
&	+	=		B	A	C					+	<		+
-				B							—	\		—
/					A	C				1	?			
1										1	=	>		±
2								2			°)	@
3						C			2	1	:	;		#
4							4				:	;		\$
5						C	4			1	%		(%
6						C	4	2			'		:	¢
7							4	2	1		"			&
8							8					*		
9						C	8			1	([(
0						C	8		2)])
a				B	A					1	A			
b				B	A				2		B			
c				B	A	C			2	1	C			
d				B	A			4			D			
e				B	A	C		4		1	E			
f				B	A	C		4	2		F			
g				B	A			4	2	1	G			
h				B	A		8				H			
i				B	A	C	8			1	I			
j				B		C				1	J			
k				B		C			2		K			
l				B					2	1	L			
m				B		C		4			M			
n				B				4		1	N			
o				B				4	2		O			
p				B		C		4	2	1	P			
q				B		C	8				Q			
r				B			8			1	R			
s					A	C			2		S			
t					A				2	1	T			
u					A	C		4			U			
v					A			4		1	V			
w					A			4	2		W			
x					A	C		4	2	1	X			
y					A	C	8				Y			
z					A		8			1	Z			

THE CODES BELOW ARE NOT PRINTABLE														
FUNCTION CODES										MEANING				
PN						C	8	4			Punch On			
BY					A		8	4			Bypass			
RES				B			8	4			Restore			
PF				B	A	C	8	4			Punch Off			
RS							8	4		1	Reader Stop			
LF					A	C	8	4		1	Line Feed			
NL				B		C	8	4		1	New Line (Carrier Return and Line Feed)			
HT				B	A		8	4		1	Horizontal Tab			
UC							8	4	2		Upper Case			
EOB					A	C	8	4	2		End of Block			
BS				B		C	8	4	2		Backspace			
LC				B	A		8	4	2		Lower Case			
EOT						C	8	4	2	1	End of Transmission			
PRE					A		8	4	2	1	Prefix			
IL				B			8	4	2	1	Idle			
DEL				B	A	C	8	4	2	1	Delete			
Space						C					Space			

Code Chart (PTTC/BCD)

NOTE: Available only on an PRQ (Request Price Quotation) basis for Model 2

LOWER CASE	Bit Value							UPPER CASE
	B	A	C	8	4	2	1	
	B	A		8		2	1	—
\$	B		C	8		2	1	!
/		A	C	8		2	1	
#				8		2	1	"
@		A						¢
&	B	A	C					+
-	B							-
/		A	C				1	?
1							1	=
2						2		<
3			C			2	1	;
4					4			:
5			C				1	%
6			C		4	2		'
7					4	2	1	>
8				8				*
9			C	8			1	(
0			C	8		2)
a	B	A					1	A
b	B	A				2		B
c	B	A	C			2	1	C
d	B	A			4			D
e	B	A	C			4	1	E
f	B	A	C		4	2		F
g	B	A			4	2	1	G
h	B	A		8				H
i	B	A	C	8			1	I
j	B		C				1	J
k	B		C			2		K
l	B					2	1	L
m	B		C		4			M
n	B				4		1	N
o	B				4	2		O
p	B		C		4	2	1	P
q	B		C	8				Q
r	B			8			1	R
s		A	C			2		S
t		A				2	1	T
u		A	C		4			U
v		A			4		1	V
w		A			4	2		W
x		A	C		4	2	1	X
y		A	C	8				Y
z		A		8			1	Z

THE CODES BELOW ARE NOT PRINTABLE

FUNCTION CODES		MEANING	
PN	C 8 4	Punch On	
BY	A 8 4	Bypass	
RES	B 8 4	Restore	
PF	B A C 8 4	Punch Off	
RS	8 4 1	Reader Stop	
LF	A C 8 4 1	Line Feed	
NL	B C 8 4 1	New Line (Carrier Return and Line Feed)	
HT	B A 8 4 1	Horizontal Tab	
UC	8 4 2	Upper Case	
EOB	A C 8 4 2	End of Block	
BS	B C 8 4 2	Backspace	
LC	B A 8 4 2	Lower Case	
EOT	C 8 4 2 1	End of Transmission	
PRE	A 8 4 2 1	Prefix	
IL	B 8 4 2 1	Idle	
DEL	B A C 8 4 2 1	Delete	
SPACE	C	Space	

Code Chart (PTTC/EBCD)

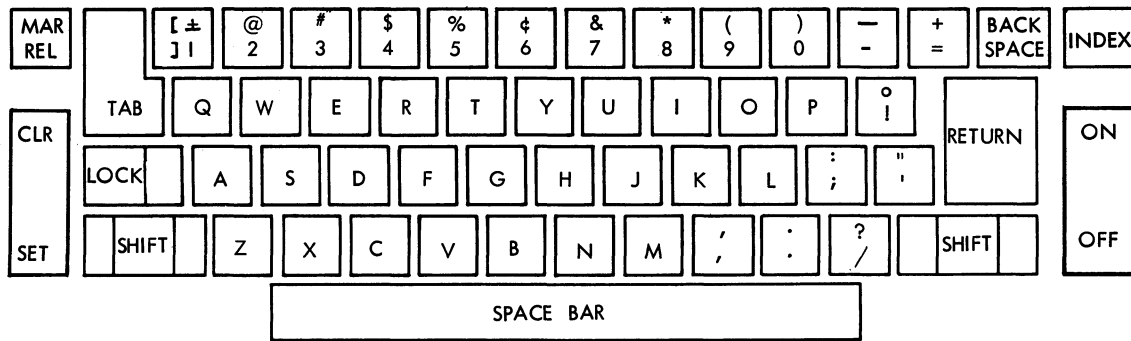

Keyboard (Standard Selectric Typewriter)

NOTE: When this keyboard and associated print elements are specified, the line code assignments of the graphic characters change and are not compatible with the PTT/BCD and PTTC/EBCD print elements and associated keyboards. This keyboard and print element is available only on an RPQ (Request Price Quotation) basis for Model 2.

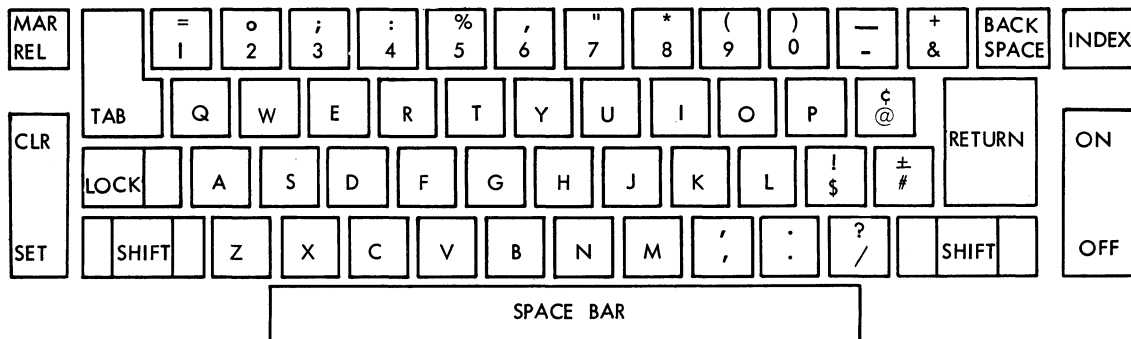

Keyboard (PTTC/BCD)

NOTE: This keyboard and print element is available only on an RPQ (Request Price Quotation) basis for Model 2.

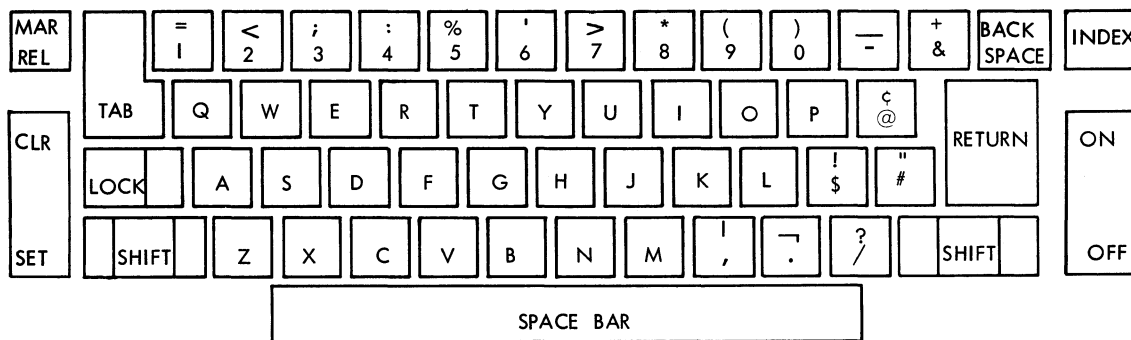

Keyboard (PTTC/EBCD)

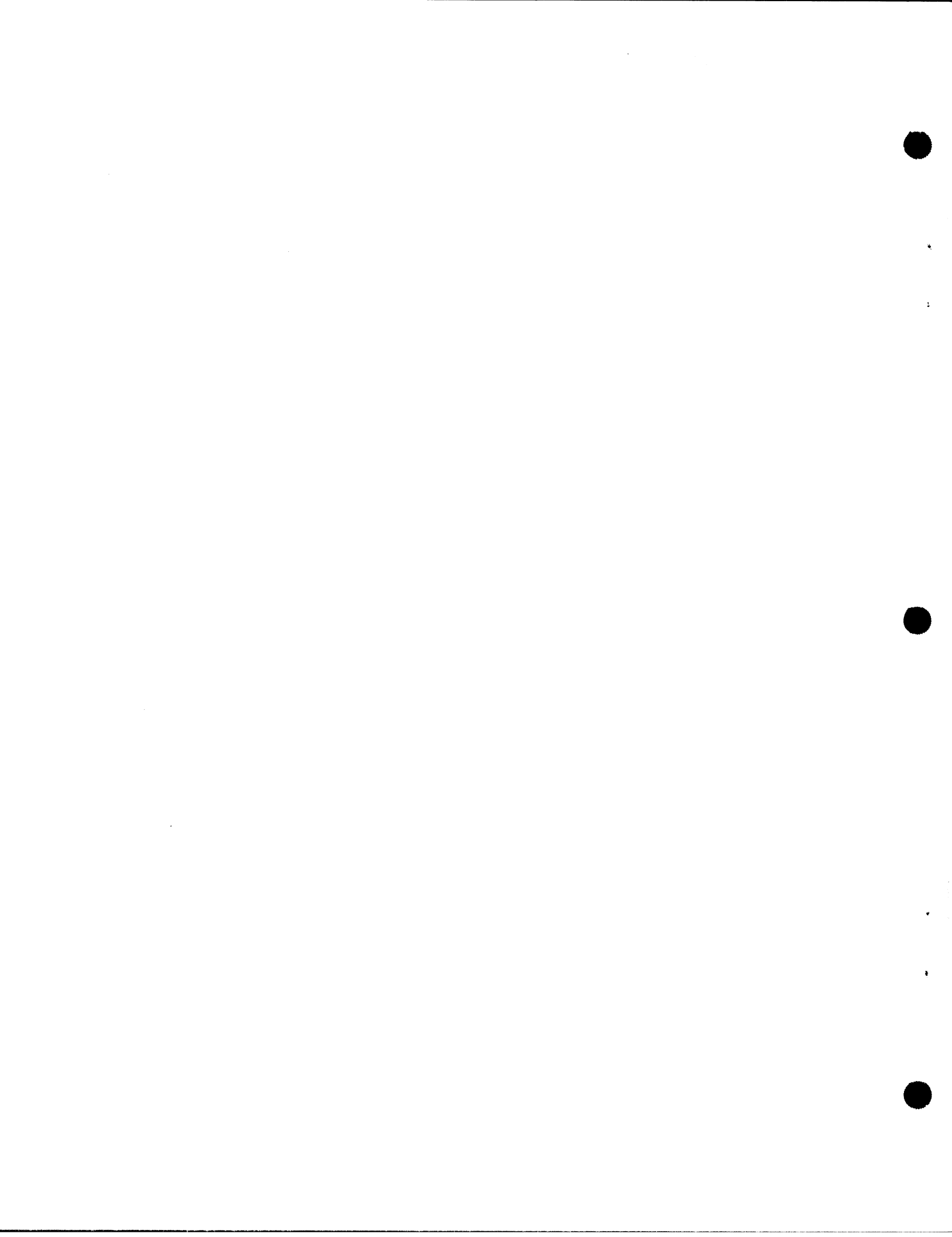

IBM 2740 MODEL 1

- Addressing Time 24
 - Answer 4
 - Appendix 49
 - Applications 3
 - Automatic Disconnect 18
 - Automatic EOB Feature 9, 21
 - ⓑ EOB Signal 4
 - Bid Key and Light 7
 - Broadcast Operation 7, 12
 - ⓒ EOT Signal 4
 - Checking (VRC-LRC) Feature 19
 - Checking Time (Receive Terminal, Negative Answerback) 24
 - Checking Time (Receive Terminal, Positive Answerback) 24
 - Checking Time (Transmit Terminal, Negative Answerback) 24
 - Checking Time (Transmit Terminal, Positive Answerback) 24
 - Check-Loop Test 8
 - Code Chart (PTTC/BCD) Appendix
 - Code Chart (PTTC/EBCD) Appendix
 - Code Chart (Standard Selectric Typewriter Print Element) Appendix
 - Communications Facilities 3
 - Data-Handling Capability 24
 - ⓓ EOA Signal 4
 - ⓓ Positive Answer, Inquiry Signal 5
 - Data Sets 4
 - Delay Conditions 23
 - Dial-Disconnect (Disc) Key and Dial-Connect Light 8
 - Dial-Up Adapter 17
 - Dial-Up Operation 3, 13
 - Dial-Up Operation (With Checking) 13
 - EOB (End-of-Block) Key 9
 - EOT (End-of-Transmission) Key 10
 - Glossary 47
 - IBM Line Adapter (Leased Line) 22
 - IBM Line Adapter (Limited-Distance Type 1) 22
 - IBM Line Adapter (Limited-Distance Type 2) 22
 - IBM Line Adapter (Shared Line) 22
 - IBM Line Adapters 22
 - IBM 2760 Attachment 22
 - Interchangeable Print Elements 1
 - Line-Control Signals 4
 - Local/Communicate Key 7
 - Ⓝ Negative Response Signal 4
 - Paper Guide, Tear Bar, and Roll Paper Holder 23
 - Pin-Feed Platens 22
 - Point-to-Point Operation 3, 7
 - Point-to-Point Operation (Multiplexer and Terminal) 14
 - Point-to-Point Operation (Multiplexer and Terminal with Dial-Up Feature Installed) 15
 - Point-to-Point Operation (Terminal-to-Terminal) 11
 - Polling Time (Negative Answerback) 24
 - Polling Time (Positive Answerback) 24
 - Principles of Operation 11
 - Receive Operation (Multiplexer and Terminal) 14
 - Receive Operation (Multiplexer and Terminal with Dial-Up Feature Installed) 15
 - Receive Operation (Terminal-to-Terminal) 12
 - Receive (R) Light 7
 - Response 4
 - Restart (RST) Key and Light 8
 - Ribbon Cartridge 2
 - Ⓢ SOA Signal 5
 - Special Features 17
 - Standby (S) Light 7
 - Station Control 3, 8
 - Station Control (Multiplexer Addressing and Polling) 16, 19
 - Stroke Storage 1
 - Terminal Transmission and Control Speed 24
 - Test Switch 10
 - Timing Considerations 23
 - Timeout Conditions 23
 - Transmission Controls and Indicators 7
 - Transmit Control 17
 - Transmit-Control Switch (MTC, OFF) 10
 - Transmit Control (Multiplexer) 16
 - Transmit Operation (Multiplexer and Terminal) 14
 - Transmit Operation (Multiplexer and Terminal with Dial-Up Feature Installed) 15
 - Transmit Operation (Terminal-to-Terminal) 11
 - Transmit (T) Light 7
 - Typamatic Index Key 1
 - Types of Operation 2
 - Typewriter Delay Conditions 23
- Ⓨ Positive Response Signal 4

IBM 2740 MODEL 2

- Addressing 36
- Appendix 49
- Attn (Attention) Light 32
- Bid Key 30
- Bid Light 32
- Bid Status 29

Buffer Expansion 39
 Buffered Receive 40

 Codes, Keyboard Arrangements, and Print Elements 29
 Communicate Mode 29, 35
 Communicate Mode, Principles of Operation 35
 Communications Facilities 28

 Data-Handling Capability 46
 Data Sets 28
 Document Design 43
 Document Insertion Feature 41

 Edit Error-Correction Routines 41
 Edit Feature 40
 Enter, Communicate Mode 29
 Enter, Local Mode 28
 Enter Key 29, 41
 Enter Light 32

 Glossary 47

 Header Control 40
 Header Switch 30

 IBM Line Adapter (Leased Line) 45
 IBM Line Adapter (Limited Distance Type 1) 44
 IBM Line Adapter (Limited Distance Type 2) 45
 IBM Line Adapter (Shared Line) 45
 Indicator Lights 31
 Introduction 27

 Keys 29

 Ledger-Card Stock 43
 Line Return Key 30, 41
 Line Type Key 30, 41
 Local Mode 28, 35

 Local Mode, Principles of Operation 35

 Modes of Operation 28, 35

 On/Off Power Switch 29

 Paper Guide, Tear Bar, and Roll Paper Holder 44
 Parity Light 32
 Parity Switch 30
 Pin-Feed Platens 44
 Platen-Split Light 32
 Polling 36
 Principles of Operation 35
 Print Back, Local Mode 28

 Receive Light 32
 Receive Status 29
 Record Checking 39
 Reset Key 30
 Reset Light 33

 Special Features 39
 Speed Base--600 bps 40
 Split Friction-Feed Platen 41
 Standby Light 31
 Standby Status 29
 Station Control (Multiplexer Addressing and Polling) 36
 Switches 30

 Telegraph Line Adapter 40
 Test Switch 30
 Timing Considerations 46
 Transmission Controls and Indicators 29
 Transmit Light 32
 Transmit Status 29
 Typewriter Delay Conditions 46
 Typewriter Local Mode 29



2

3



4

5



IBM

International Business Machines Corporation
Data Processing Division
112 East Post Road, White Plains, N.Y. 10601
[USA Only]

IBM World Trade Corporation
821 United Nations Plaza, New York, New York 10017
[International]

Staple

YOUR COMMENTS, PLEASE . . .

This publication is one of a series that serves as a reference source for systems analysts, programmers, and operators of IBM systems. Your answers to the questions on the back of this form, together with your comments, help us produce better publications for your use. Each reply is carefully reviewed by the persons responsible for writing and publishing this material. All comments and suggestions become the property of IBM.

Please note: Requests for copies of publications and for assistance in using your IBM system should be directed to your IBM representative or to the IBM sales office serving your locality.

Fold

Fold

FIRST CLASS
PERMIT NO. 155
RALEIGH, N. C.

BUSINESS REPLY MAIL
NO POSTAGE NECESSARY IF MAILED IN THE UNITED STATES



POSTAGE WILL BE PAID BY . . .

IBM Corporation
P.O. Box 12275
Research Triangle Park
North Carolina 27709

Attention: Product Publications, Dept. 860

Fold

Fold

Cut Along Line

Additional Comments: