



System/360
System/370



Operator's Reference Guide



System/360
System/370

Operator's Reference Guide

This edition (October 1971) of the Operator's Reference Guide (SR20-1078-3) is a major revision which obsoletes and replaces all previous editions of this publication.

Requests for copies of IBM publications should be made to your IBM representative or to the IBM branch office serving your locality. Address comments concerning the contents of this publication to IBM Corporation, DPD Education Development - Publications Services, Education Center, South Road, Poughkeepsie, New York 12602.

© Copyright International Business Machines Corporation 1968, 1971

	PAGE	
SECTION I	Trouble Analysis Flow Charts	1
SECTION II	Central Processor Unit (CPU) Manual Procedures	17
	● Functional Characteristics of Manual Controls	17
	● How to Display the Current PSW	19
	● Alter the Current PSW	23
	● Alter Main Storage	25
	● Display Main Storage	29
	● Clear Main Storage	31
	● Display a General Purpose Register	34
	● Alter a General Purpose Register	36
	● Stop on Main Storage Address	38
	● Power-On Procedure	40
	● Power-Off Procedure	40
	● Record ROS Address	41
SECTION III	General Information	43
	● How to Call IBM for Service	43
	● Doubleword Layout	44
	● Hexadecimal and Decimal Conversion	44
	● Code Charts	45
	● Program Status Word Layout	46
	● Code for Program Interruption	46
	● Permanent Storage Assignment	46
	● Condition Code Setting	47
	● Input/Output Operations and Commands	48
	● 2400/3420 MTU Command Code Format	51
	● Message Format for DOS/TOS	53
	● Message Format for OS	54
	● 1052 and 1442 Status and Sense Data	61
	● 1443 Status and Sense Data	62
	● 2250 and 2821 Sense Data	63
	● 2803 Sense Data	64
	● 2800/2400 Tape Control	65
	● 2841 Sense Data	71
SECTION IV	IPL and Checkpoint Restart Procedures	75
	● Operating System IPL Procedure	77
	● DOS/TOS IPL Procedure	82
	● O/S (PCP) Checkpoint Restart	83
	● O/S (MFT/MVT) Checkpoint Restart	83
	● Restarting a Job From a Checkpoint (DOS)	84
SECTION V	I/O Device Handling Procedures	85
	● General Hints About Tape Drives	85
	● 24XX Tape Drives	86
	● 3420 Tape Drives	88
	● 23XX Direct Access	92
	● 2314 Operator Controls and Indicators	95
	● Printers - General	100
	1443 Printer	101
	1403 Printer	103
	● 2501 Card Reader	106
	● Restart Procedures	107
	● 2520 Card Punch	108
	● 2540 Card Read Punch	109
	Operating and Restart Procedures	110
	● Restart Procedures - Standard and PFR Operation	112
	● 1442 N1, N2	120
	● Card Readers - General	121

SECTION VI	System Operating Commands	123
	● OS PCP and MFT-I Commands	123
	● MVT and MFT Commands	129
	DOS/TOS Operator to System Communication	147
SECTION VII	Utilities	165
	● OS	165
	● IBCDASDI	168
	● IBCDMPRS	175
	● SEREP	179
	● OLTEP for OS	186
	● OLTEP for DOS	194
SECTION VIII	Bibliography	197

TROUBLE ANALYSIS

DEFINITION OF SYMBOLS USED IN FLOW CHARTS

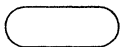

Starting or terminating step.

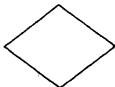

Question block which is asking for a "yes - no" or "on - off" answer. Output lines will be labeled.



Indicates some action is required or gives a brief description of situation.



Refers reader to some other page for directions of particular operator action required.



Number within this symbol indicates one of the following:

1. Page number which references this page.
2. This page number, if this is a common entry from several other pages
3. Page to exit to in order to continue usage of charts

TROUBLE ANALYSIS (continued)

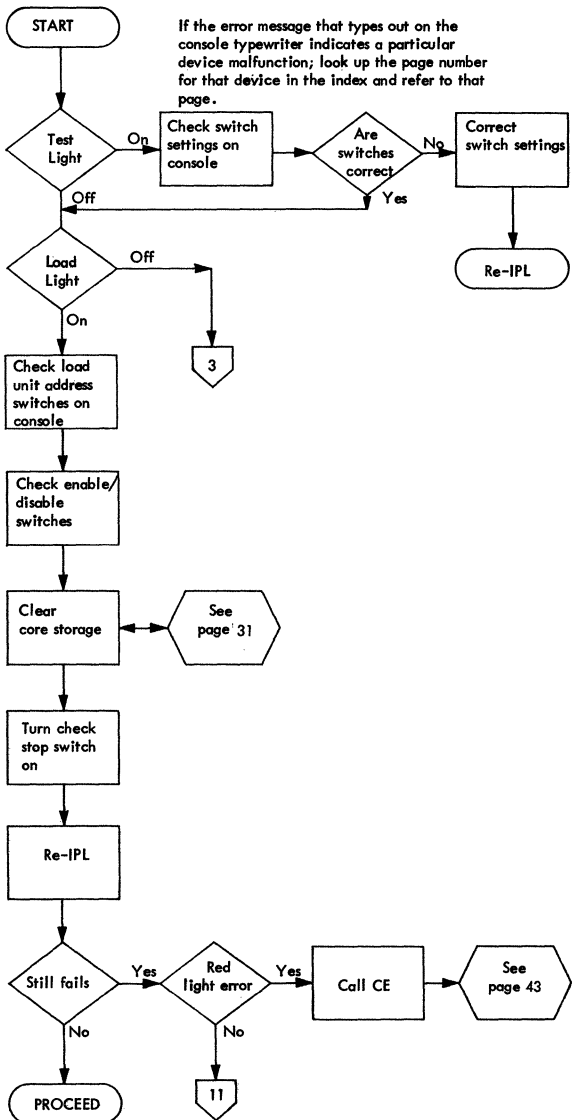

TROUBLE ANALYSIS (continued)

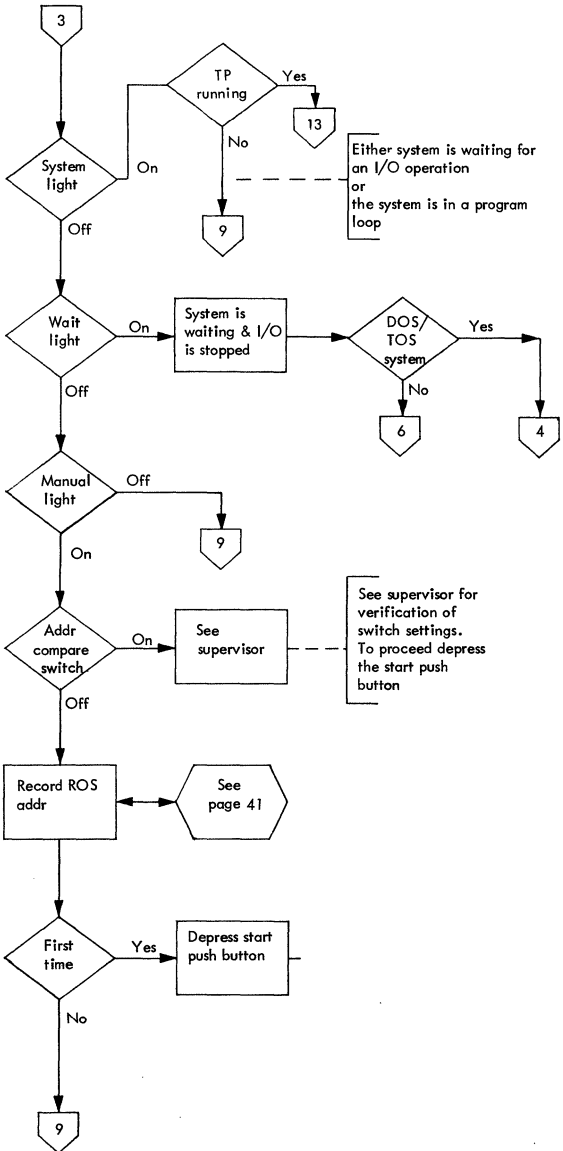

TRUBLE ANALYSIS (continued)

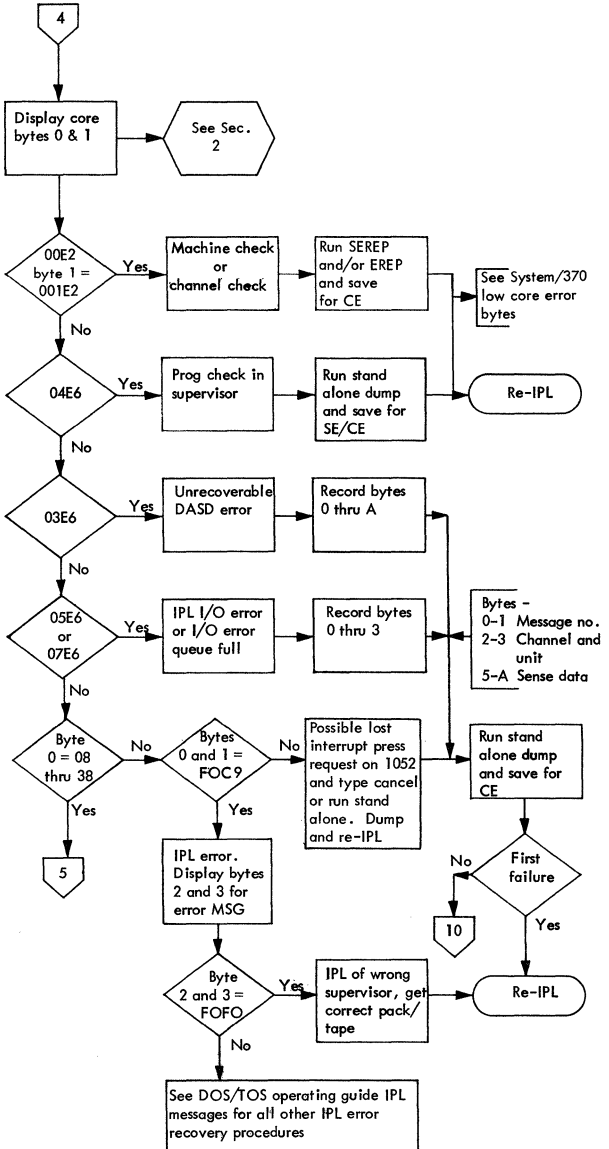

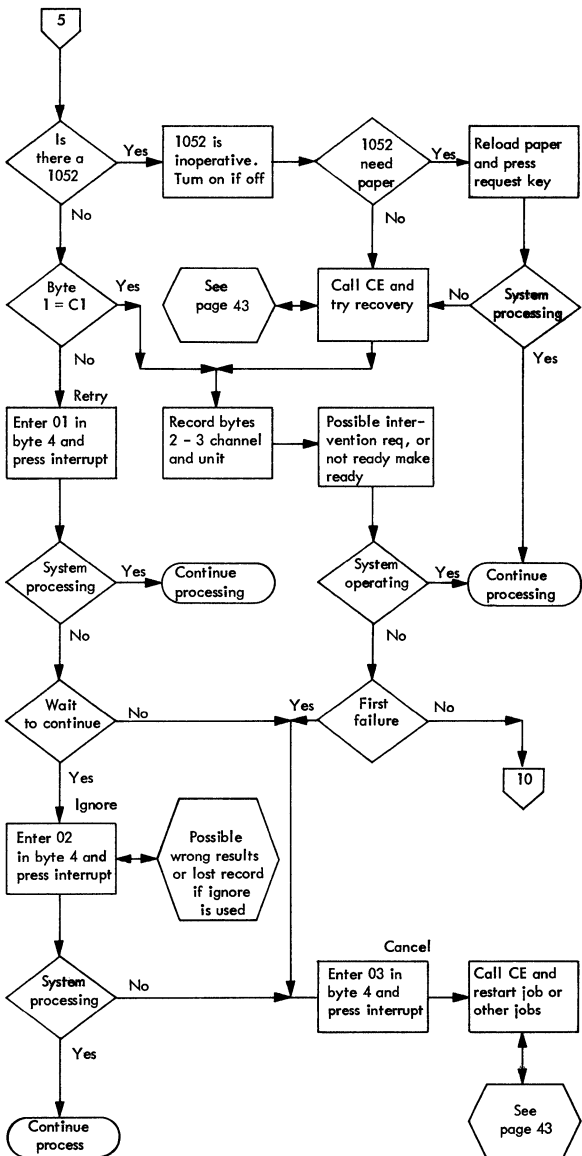

TROUBLE ANALYSIS (continued)

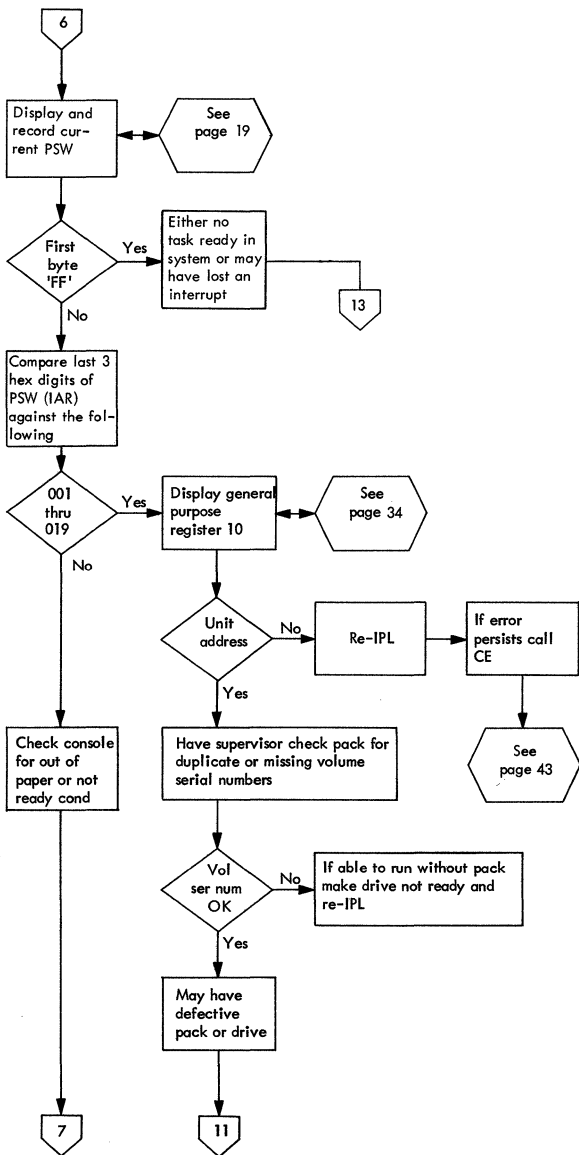

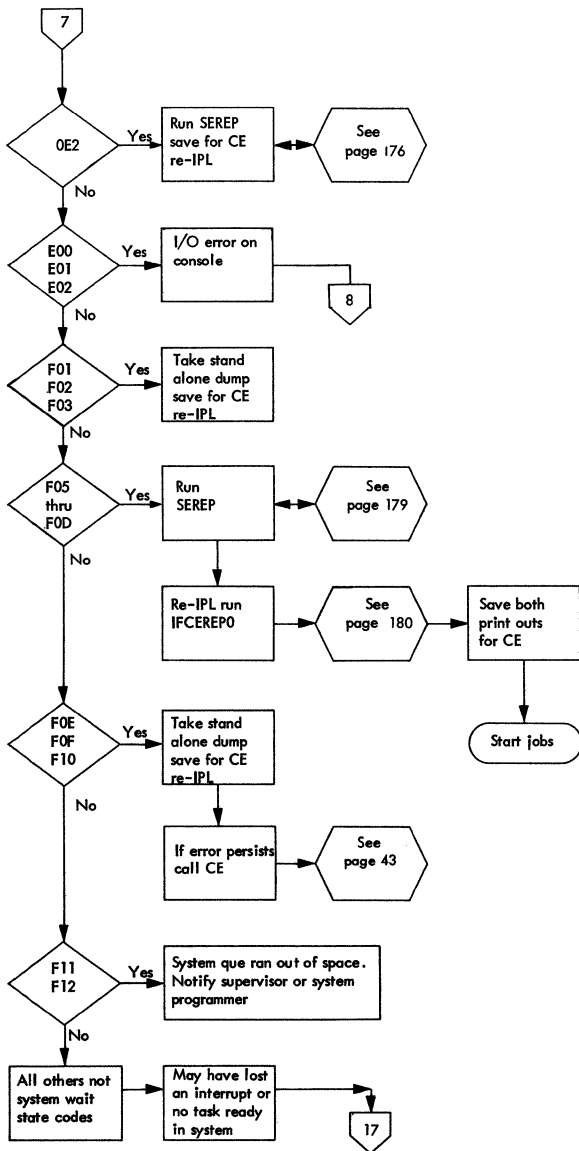

TROUBLE ANALYSIS (continued)

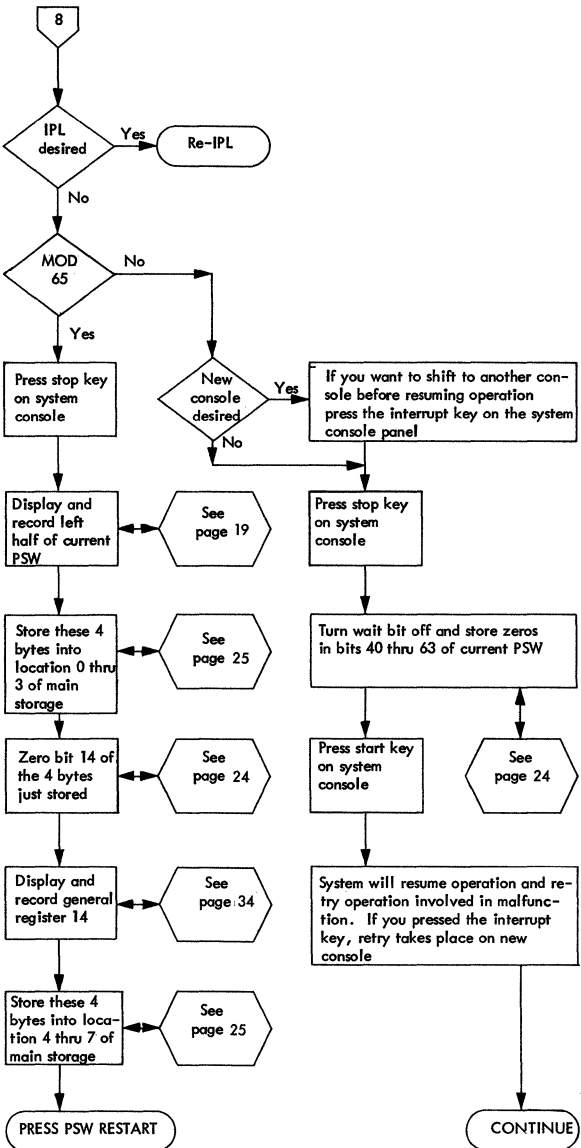

TROUBLE ANALYSIS (continued)

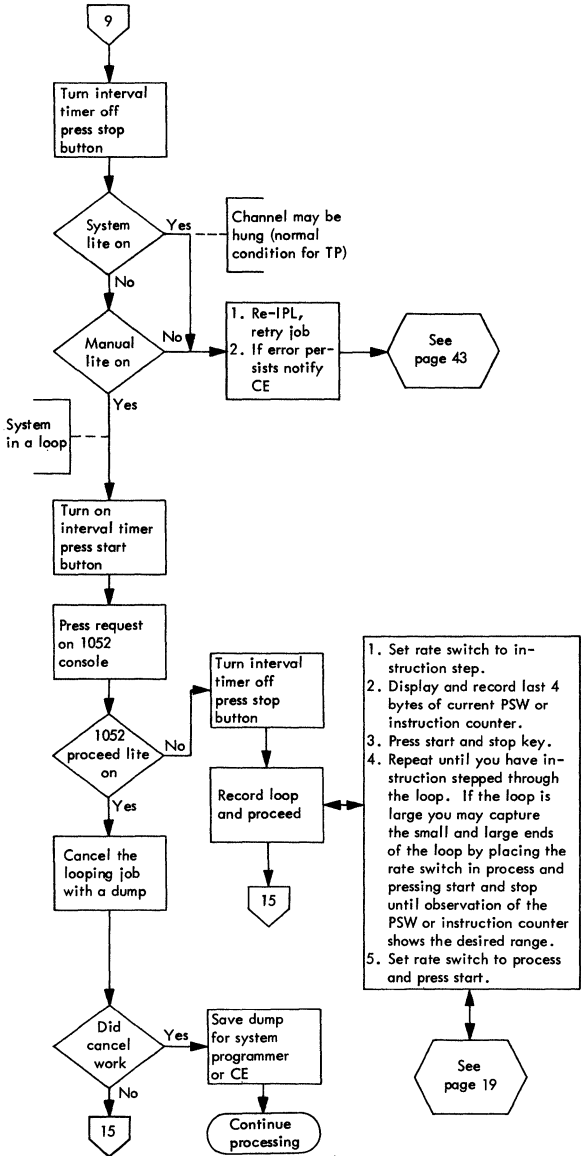

TROUBLE ANALYSIS (continued)

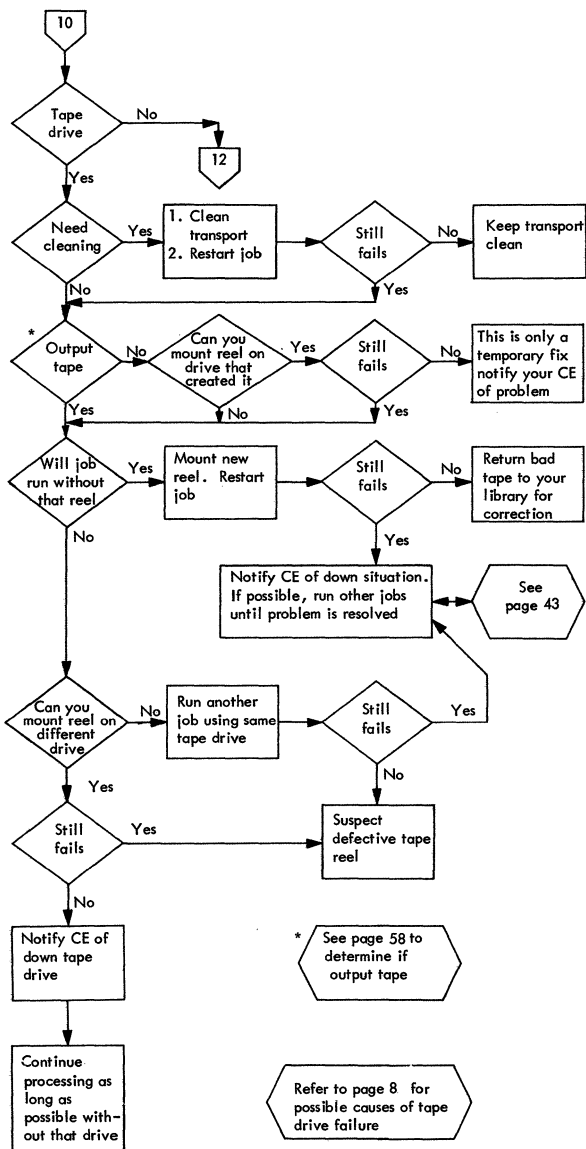

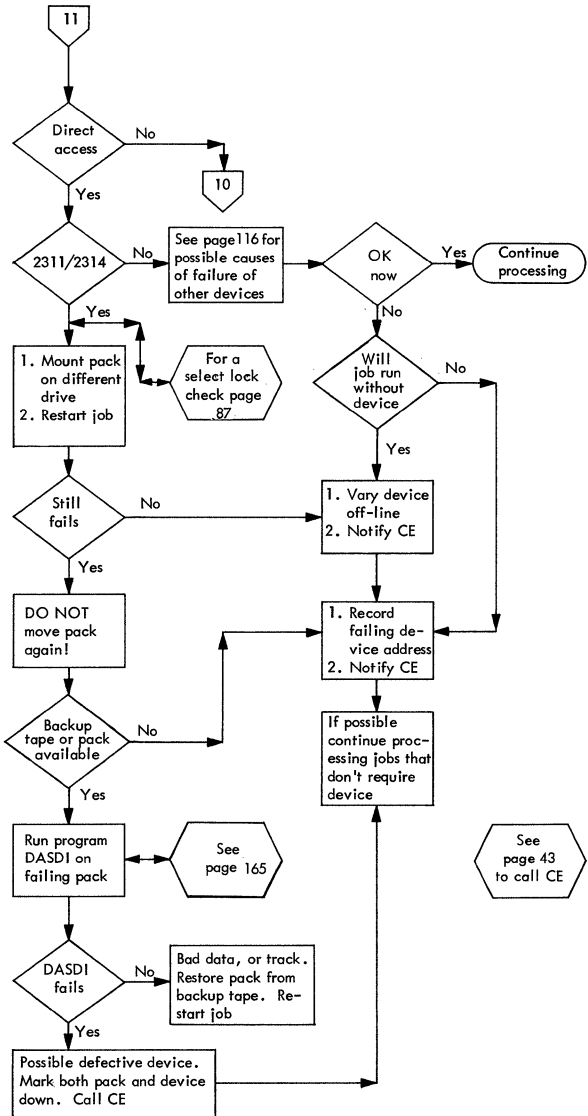

TROUBLE ANALYSIS (continued)

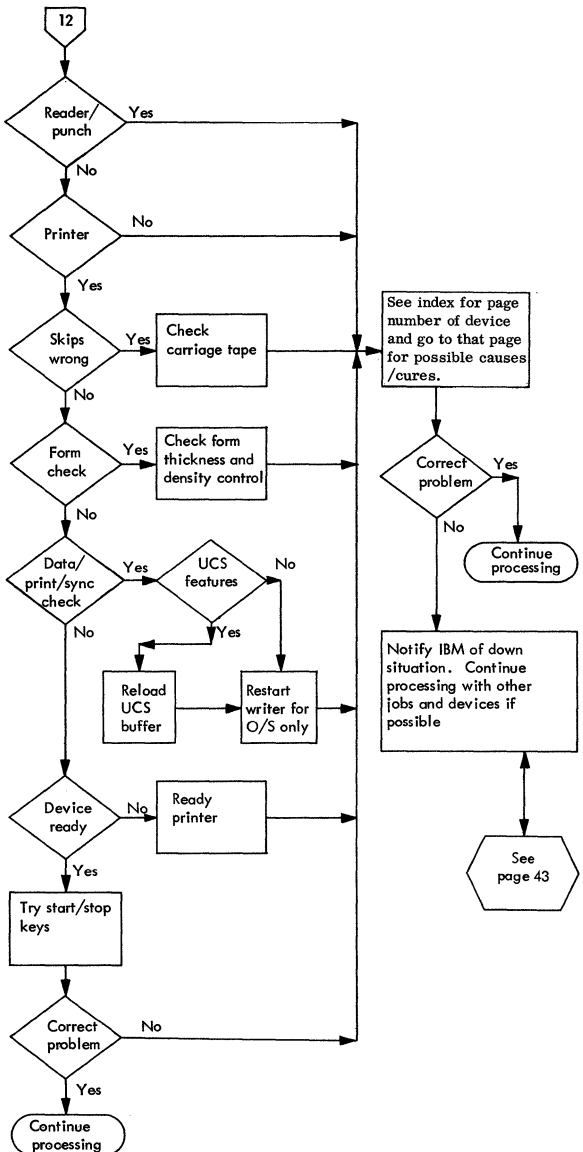

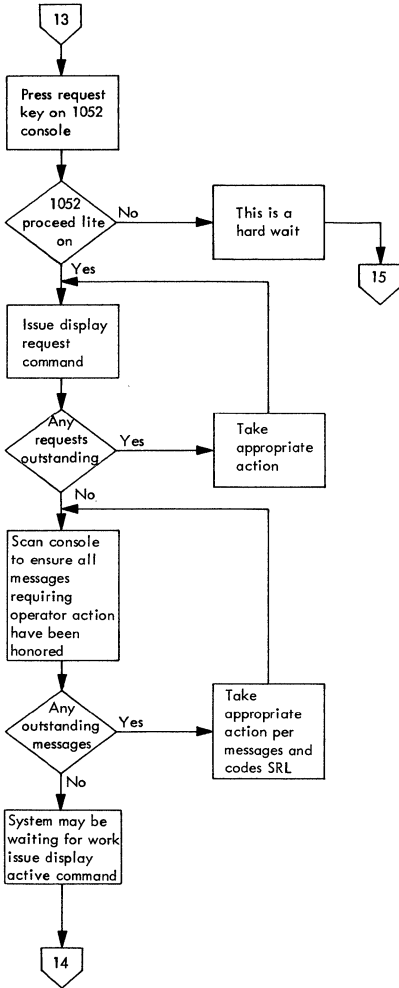

TROUBLE ANALYSIS (continued)

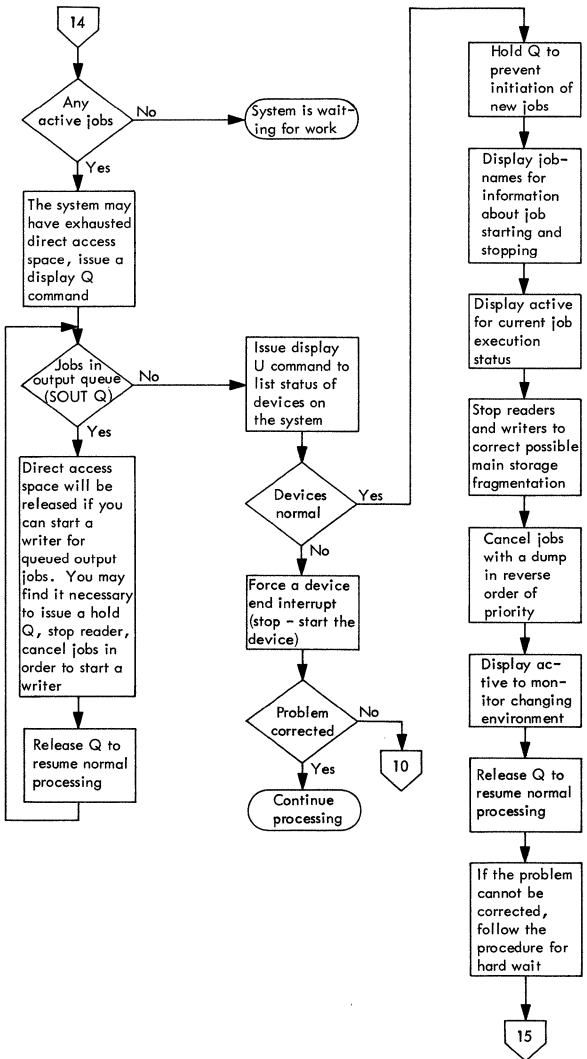

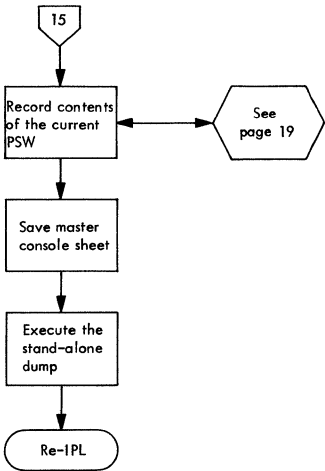



FUNCTIONAL CHARACTERISTICS OF MANUAL CONTROLS

This chapter is a grouping of techniques and related data you will need to use in running the system.

LOAD key	Loads an IPL program.
START key	Starts instruction execution. (Works only if the CPU is in the stopped mode.)
STOP key	Puts the CPU in the stopped mode.
SYSTEM RESET key	Interrupts instruction processing, and resets the CPU, channels, on-line non-shared control units, and I/O devices. Does <u>not</u> reset registers.
CHECK RESET key	Resets the console check lights.
INTERRUPT key	Interrupts program execution by causing an external interruption. The operating system allows you to switch from the primary console to the alternate console. -OS only
DISPLAY key	Displays information you specify by setting appropriate panel switches. Works only if the CPU is in the stopped mode.
ADDRESS COMPARE switch	Stops the CPU when it reaches any address you select in advance. Used to load a secondary nucleus at IPL time. -OS only
LOAD UNIT switches	Tell the system where to get the IPL program when you push the LOAD key.
PR-KB	The printer-keyboard is an I/O device that provides alter/display and operator control functions.
RATE switch	Sets the rate the CPU will operate at (used only when the CPU is already in stopped mode): PROCESS rate -- normal speed; INSTRUCTION STEP rate -- one whole instruction per push of the START key; SINGLE CYCLE rate -- one whole micro-program instruction per push of the START key.
STORAGE SELECT switch	Works only if the CPU is in the stopped mode. Selects the storage area addressed by the address switches: FP -- floating point registers GP -- general purpose registers PSW -- current program status word MS -- main storage LS -- local storage SP -- storage protection IC -- instruction counter
LOAD light	Goes on when the LOAD key is pushed, goes off when the IPL chain is broken.
WAIT light	Goes on when the CPU is in the wait state.

MANUAL light	Goes on when the CPU is in the stopped mode.
TEST light	Goes on when the switches with a NORMAL position are not pointing to that position.
SYSTEM light	Goes on when the CPU or channels are running.
STORAGE DATA lights	Goes on after the DISPLAY key is pressed when their corresponding keys are set to specify data to be loaded into storage or into registers.

HOW TO DISPLAY THE CURRENT PSW

Displaying the PSW varies from one machine model to the next, so the steps are described according to model number.

PSW For Model 20 Only

Left Half of Current PSW

Not Used	C C	Not Used	ASCII	CHAN Mask	Device Address	Function Specification
----------	-----	----------	-------	-----------	----------------	------------------------

0 1 2 3 4 5 6 7 8 9 10 11 12 13 14 15

Right Half of Current PSW

Next Sequential Instruction Address

16

31

On the Model 20

Main storage displaying is done one byte at a time on the Model 20. Register displaying, including displaying the current PSW, is done two bytes at a time on the Model 20.

- Press STOP
- Turn MODE switch to the DISPLAY REGISTER position.
- Turn DATA SWITCH 1 to position 2 for left half of PSW or position 3 for right half of current PSW.
- Depress START key.
- Proper halfword is displayed in the E, S, T, and R registers.

Left Half of Current PSW

System Mask	Key	AMWP	Interruption Code
-------------	-----	------	-------------------

0 8 12 16 31

Not valid in
Current PSW

Normal Right Half of Current PSW

ILC	CC	Program Mask	Instruction Address
-----	----	--------------	---------------------

32 34 36 40 63

On the Model 25

Aux storage and main storage displaying is done two bytes at a time on the Model 25. Local storage displaying is done one byte at a time on the Model 25.

To display System Mask, Key, AMWP:

- Press STOP.
- Set MODE switch to A S DATA position.
- Set console switches A, B, C, and D to 00A8.
- Depress DISPLAY key.
- System mask, key, and AMWP will be displayed in the BYTE 0 and BYTE 1 indicators.

HOW TO DISPLAY THE CURRENT PSW (continued)

To display rest of PSW:

- Set MODE switch to MOD/LS position - information will now be coming out of local storage and can only be displayed one byte at a time in the console BYTE 1 indicators.
- Set console switches A and B to 00.
- Set console switches C and D to the desired location. PSW fields will be found at the locations below.

Switch C D

Instruction Length	84 (bits 0 and 1 of BYTE 1)
Condition Code	8C (bits 0 thru 3 of BYTE 1)
Program Mask	8D (bits 0 thru 3 of BYTE 1)
Instruction Address	88 and 89

Note: The 4 bit decode of the condition code is as follows:

Bits -	0	1	2	3
Cond. code 0 -	0	0	0	0
Cond. code 1 -	0	1	0	1
Cond. code 2 -	0	0	1	0
Cond. code 3 -	0	1	1	1

On the Model 30

Storage displaying, including displaying the current PSW, is done one byte at a time on the Model 30.

- Press STOP.
- Turn the STORAGE SELECT switch E to 'AS' with red flag up.
- Turn switch A to 'LS' or numeric 7.
- Turn MAIN STORAGE switches: B to zero, C and D to the desired location. PSW fields will be found at the locations below.

Switch C D

System Mask	B8
Protect Key	B9 (high order 4 bits)
AMWP	B9 (low order 4 bits)
Interruption Code	External old PSW (bits 16-31)
Instruction Length	8C (bits 4 and 5)
Condition Code	BB (high order 4 bits)
Program Mask	BB (low order 4 bits)
Instruction Address	A9 & AA (or I & J register)

Note: Condition code is displayed as four bits (8, 4, 2, 1), one bit at a time.

- Press DISPLAY to display the data in the main storage data register and the address in the low order eight bits of the main storage address register.

HOW TO DISPLAY THE CURRENT PSW (continued)

On the Model 40

Storage displaying, including displaying the current PSW, is done two bytes at a time on the Model 40.

- Press STOP.
- Set the STORAGE SELECT switch to PSW.
- Set the STORAGE ADDRESS bit switches as follows:

All bits off for the first half-word of the PSW.

Bit 7 on for the second half-word.

Bit 6 on for the third.

Bits 6 and 7 on for the last half-word.

- Press the DISPLAY key.

On the Model 44

- Depress the STOP key.
- Turn the STORAGE SELECT switch to the desired half of the PSW.
- Depress the DISPLAY key.

On the Model 50

Storage displaying, including displaying the current PSW, is done 4 bytes (one word) at a time on the Model 50.

- Press STOP.
- Set the ADDRESS switches to 170.
- Set the STORAGE SELECT switch to LOCAL.
- Press the DISPLAY key.
- Rotate roller 3 (CPU 1) to position 1, showing the L register which contains the first half of the PSW.
- Rotate roller 4 (CPU 2) to position 3 and examine bits 32-39, labeled PSW, to find the first byte of the second word of the PSW.
- The last three bytes of the PSW are in the instruction address register.

On the Model 65

Storage displaying, including displaying the current PSW, is done eight bytes (two separate words) at a time on the Model 65.

- Press STOP.
- Look at roller 4 position 1 for the left half of the current PSW, CC and program mask.
- Look at the D register (roller 1 position 2) for the Instruction Address.

On the Model 75

Storage displaying, including displaying the current PSW, is done eight bytes (one whole double-word) at a time on the Model 75.

- Press STOP.
- Look at the PSW register indicator lights for the current PSW.

HOW TO DISPLAY THE CURRENT PSW (continued)

On the Model 91/95

Storage displaying, including displaying the current PSW, is done eight bytes (one whole double word) at a time on the Model 91/95.

- Press STOP.
- Look at the PSW register indicator lights for the current PSW.

Note: To insure the validity of the instruction address, be sure machine is in the STOP STATE. If this cannot be done by depressing the STOP button, it may be necessary to either hit SYSTEM RESET button or put the RATE switch to the SINGLE CYCLE position and depress the HARD STOP button.

On the Model 145/155

Refer to Alter/Display Operations on the Model 145/155 (page 27).

On the Model 165

- Press STOP.
- Set CRT MODE SELECT to CE.
- See bits 40-63 at IC on CRT.
- See bits 0-15 and 32-39 at image A3 on indicator viewer. (Bits 16-31 are 0's.)
- To resume, set CRT MODE SELECT to OP and press START.

ALTER THE CURRENT PROGRAM STATUS WORD (PSW)

On the Model 20

- Press STOP.
- Turn MODE switch to the ALTER REGISTER position.
- Turn DATA SWITCH 1 to position 2 to alter the left half of current PSW or position 3 to alter the right half of current PSW.
- Set new data in switches E, S, T, and R.
- Depress START key.

On the Model 25

Note: An alter function must be preceded by a display function on the Model 25

- To alter system mask, key, AMWP area.
- Do a PSW display operation to the system mask, key, and AMWP area.
- Put desired information in console switches A, B, C, and D.
- Depress STORE key.
- To alter any part of rest of PSW.
- Do a PSW display operation on the desired area of the PSW to be changed.
- Put desired information in console switches A and B.
- Depress STORE key.

On the Model 30

- Proceed as in displaying the current PSW.
- Put new data in the data keys.
- Hit STORE and the new data will be entered.

On the Model 40

- Proceed as in displaying the current PSW.
- Put new data in the data keys.
- Hit STORE and the new data will be entered.

On the Model 44

- Depress the STOP key.
- Turn the STORAGE SELECT switch to the desired half of the PSW.
- Enter the desired PSW information in the DATA SWITCHES.
- Depress the STORE key.

On the Model 50

- Be sure machine is in manual mode.
- Record address in INSTRUCTION ADDRESS REGISTER.
- Set address keys to 170.
- Set storage switch to LOCAL.
- Put new data in data keys.
- Hit STORE and new data will be entered.
- Hit SYSTEM RESET key.
- Put address noted in step 2 in address keys.
- Hit SET IC key.

ALTER THE CURRENT PROGRAM STATUS WORD (PSW) (continued)

On the Model 65

- Put new PSW doubleword in the data keys.
- Store the data at location zero.
- Hit PSW RESTART.

On the Model 75

- Put new PSW doubleword in the data keys.
- Hit SET PSW. The whole PSW, including the instruction counter, will be set to that data.

On the Model 91/95

- Put new PSW in CBR data keys.
- Hit SET PSW. The whole PSW, including the instruction counter, will be set to that data.

On the Model 145 and 155

Refer to Alter/Display Operations on the Model 145/155 (page 27).

On the Model 165

- Press STOP.
- Set CRT MODE SELECT to CE.
- See bits 40-63 at IC on CRT.
- See bits 0-15 and 32-39 at image A3 on indicator viewer. (Bits 16-31 are 0's.)
- Set MANUAL ENTRY SELECT to MCDR.
- Enter desired data via data keys. (If error is made, press \Rightarrow until wraparound, then return to desired byte and enter correct data.)
- When all eight bytes are in MCDR, press SET PSW. To verify, perform steps 1-4 of "Display Current PSW."
- To resume, set CRT MODE SELECT to OP and press START.

TO ALTER MAIN STORAGE

On the Model 20

- Press STOP.
- Turn MODE switch to STORAGE ALTER position.
- Set new hex data byte in DATA SWITCH 1 and DATA SWITCH 2.
- Set the address to be altered in switches E, S, T, and R.
- Depress START key.

On the Model 25

- Do a display function on the desired address.
- Set Data into console switches A, B, C, D.
- Depress STORE key.

On the Model 30

- Set up address as you would in displaying main storage (machine must be in manual mode).
- Set the byte of data to be stored into the rotary data switches H and J (use hexadecimal representation of data).
- Press STORE; the new data is displayed in the main storage data register.

On the Model 40

- Set up address as you would in displaying main storage.
- Set the half-word of data to be entered into the data keys.
- Press STORE.

On the Model 44

- Depress the STOP key.
- Turn the STORAGE SELECT switch to MS.
- Set the address of the location to be modified in the STORAGE ADDRESS switches.
- Set the data to be stored in the DATA SWITCHES.
- Depress the STORE key.

On the Model 50

- Machine must be in manual mode.
- Set address to be stored into, in the address keys.
- Set STORAGE SELECT switch to MAIN.
- Put data to be stored in the data keys.
- Press STORE.

Note: Any location not ending in 0, 4, 8, or C. must be stored at its proper byte location in the selected word.

TO ALTER MAIN STORAGE (continued)

On the Model 65

To alter a doubleword:

- Press STOP.
- Put address to be altered in the address keys.
- Set STORAGE SELECT to MAIN.
- Put data in the 64 data keys.
- Press STORE.

To alter a byte do the same as above but:

- Put into address keys 21-23 the byte number of the data keys that are to be stored.
- Set STORAGE SELECT to MAIN BYTE.
- Press STORE.

On the Model 75

- Press STOP.
- Set address switches to the location of the lowest byte of the doubleword to be altered.
- Set STORAGE SELECT to MAIN STOR.
- Press DISPLAY. Contents of doubleword will be displayed in J register.
- Set data switches to match J register.
- Set new information in the appropriate data switches.
- Press STORE.
- Repeat first four steps to check for accuracy.

On the Model 91/95

- Press STOP.
- Set ADDRESS switches (CAR) to the lowest doubleword that contains the byte(s) to be altered.
- Set STORE/DISPLAY to main storage.
- Press DISPLAY. Contents of the doubleword will be displayed in the CBR pos 0-31, 32-63.
- Set CBR data switches to match CBR lights.
- Set new information in appropriate CBR data switches.
- Press STORE.
- Repeat first four steps to check for accuracy.

TO ALTER MAIN STORAGE (continued)

On the Model 145 and 155

Alter/display operations are performed by the operator from the PR-KB. The PR-KB provides a record of the operation, the location(s) accessed, and the data involved.

Display operations print data from storage for inspection by the operator. The data is not changed.

Alter operations change the stored data.

Alter/Display Procedure:

- Press the CPU STOP key.
- Press the ALTER/DISPLAY key.
- Wait for both ALTER/DISPLAY MODE and PROCEED to turn on.
- Type the appropriate two-character mnemonic and address of the information or register to be altered or displayed from the following.

Storage Area	Alter Mnemonic	Display Mnemonic	Address Range
Main Storage	AM	DM	000000-03FFFF
Storage Key	AK	DK	000000-03FFFF
General-Purpose Register	AG	DG	0-F
Floating-Point Register	AF	DF	0, 2, 4, 6
Current PSW	AP	DP	None required

Alter: Data may be entered, one digit at a time, using the spacebar to skip over positions not being altered. The data in the skipped-over positions remains unchanged and prints out each time the spacebar is operated. To end the alter operation, press the ALTER/DISPLAY or END key.

Display: Data is printed starting at the address specified and continues until the ALTER/DISPLAY or END key is pressed. When zeros are typed to the left of the address, the operation is started automatically. When zeros are not inserted, press the RETURN key.

- To continue program processing, press the CPU START key.

TO ALTER MAIN STORAGE (continued)

On the Model 145 and 155 (continued)

Note: When the operation is ended with the ALTER/DISPLAY key, the PR-KB remains in alter/display mode (ALTER/DISPLAY MODE indicator on).

When the operation is terminated with the END key, alter/display mode is terminated.

For alter/display of general-purpose and floating-point registers, a wraparound is performed (F to 0 for GP registers, and 6 to 0 for floating-point registers).

When addressing main storage, either a word or byte address may be used. If the starting address is not on a word boundary, the PR-KB spaces and aligns at the byte addressed.

Alter/Display Error Messages

INVAL CHAR prints when one of the following errors occurs:

- The first character of a mnemonic is not A or D.
- The second character is not M, S, L, K, C, G, F, or P. S, L, and C are used by service personnel.
- An invalid digit is typed when addressing or altering data.
- The CANCEL key is pressed.

INVAL ADDR prints when one of the following errors occurs:

- Invalid starting address.
- The updated address exceeds the capacity of specified storage.

On the Model 165

- Press STOP.
- Set CRT MODE SELECT to CE and MANUAL ENTRY SELECT to MCAR.
- Set STORAGE SELECT to MAIN STOR.
- Press ⇨ until cursor underscores second byte.
- Enter six-digit-hex address via data keys. (If error is made, press ⇨ until wraparound, then return to desired byte and enter correct data.)
- When six-digit address shows at MCAR, press DISPLAY. See eight bytes of storage displayed at MCAR on the CRT.
- To see next doubleword, press ADV ADDRESS, then press DISPLAY.
- Press ⇨ until cursor underscores desired byte.
- Enter desired data via data keys. (If error is made press ⇨ until wraparound, then return to desired byte and enter correct data.)
- When MCDR shows desired data (eight bytes), press STORE. To verify, perform steps 1-7 of "Display Storage."
- To resume, set CRT MODE SELECT to OP and press START.

TO DISPLAY MAIN STORAGE

On the Model 20

- Press STOP.
- Turn MODE switch to STORAGE DISPLAY position.
- Set the display address in switches E, S, T, and R.
- Depress START key.
- Data byte is displayed in the U and L registers.

On the Model 25

- Press STOP.
- Set MODE switch to the MS DATA position.
- Set console switches A, B, C, and D, to the lowest halfword that contains the byte(s) to be displayed.
- Hit DISPLAY key.
- Data will be displayed in the BYTE 0 and BYTE 1 indicators.

On the Model 30

- Press STOP.
- Turn the STORAGE SELECT switch E to 'MS' with the red flag up.
- Turn the main storage address switches A, B, C, and D to the address to be displayed.
- Press DISPLAY. The data will be in the main storage data register, while the address will be in the main storage address register.

On the Model 40

- Press STOP.
- Set the STORAGE SELECT switch to 'MS'.
- Set the STORAGE ADDRESS switches to the address to be displayed.
- Press DISPLAY. The data will be in the STORAGE DATA registers, bytes 0 and 1.

On the Model 44

- Depress the STOP key.
- Turn the STORAGE SELECT switch to MS.
- Set the address to be displayed in the STORAGE ADDRESS switches.
- Depress the DISPLAY key.

On the Model 50

- Press STOP.
- Set the address switches to the address to be displayed.
- Set the STORAGE SELECT switch to MAIN.
- Press DISPLAY. The data will be in the storage data register.

On the Model 65

- Press STOP.
- Set the STORAGE SELECT lever switch to the middle position—main storage.
- Set the address switches to the address to be displayed.
- Press DISPLAY. The data will be in the ST register (roller 1 position 3 and roller 2 position 3), the AB register (roller 3 position 3 and roller 4 position 3) and position 0 and 1 of E register - ILC (roller 5 position 3).

TO DISPLAY MAIN STORAGE (continued)

On the Model 75

- Press STOP.
- Set the STORAGE SELECT switch to MAIN STOR.
- Set the address switches to the address to be displayed.
- Press DISPLAY. The data will be in the J register.

On the Model 91/95

- Press STOP.
- Set the STORE/DISPLAY switch to STORAGE.
- Set address switches (CAR) to the lowest doubleword that contains the byte(s) to be displayed.
- Press DISPLAY. The data will be in the CBR pos 0-31, 32-63.

On the Model 145 and 155

Refer to Alter/Display Operations on the Model 145/155 (page 27).

On the Model 165

- Press STOP.
- Set CRT MODE SELECT to CE and MANUAL ENTRY SELECT to MCAR.
- Set STORAGE SELECT to MAIN STOR.
- Press ⇒ until cursor underscores second byte.
- Enter six-digit-hex address via data keys. (If error is made, press ⇒ until wraparound, then return to desired byte and enter correct data.)
- When six-digit address shows at MCAR, press DISPLAY. See eight bytes of storage displayed at MCAR on the CRT.
- To see next doubleword, press ADV ADDRESS, then press DISPLAY.
- To resume, set CRT MODE SELECT to OP and press START.

HOW TO CLEAR MAIN STORAGE

On the Model 20

- Press STOP.
- Set MODE switch to the STORAGE CLEAR position.
- Set starting address in switches E, S, T, and R.
- Depress START key.
- To stop operation, depress STOP key.

On the Model 25

- Press STOP.
- Put MODE switch to any position in the SINGLE CYCLE range.
- Set console switches A, B, C, D, to 0000.
- Set DIAGNOSTIC CTRL switch to the LOAD PRGM STOR position.
- Put MODE switch to the PROCESS position.
- Depress SYSTEM RESET key.
- Depress START key.

On the Model 30

- Press STOP.
- Set instruction address keys to 0BF8.
- Set ROS CONTROL to ROS SCAN.
- Set CHECK CONTROL to DISABLE.
- Press SYSTEM RESET.
- Press ROAR RESET.
- Press START.
- To stop the clearing process momentarily set RATE switch to SINGLE CYCLE.
- Press SYSTEM RESET.

On the Model 40

- Press STOP.
- Set CHECK CONTROL to DISABLE.
- Disable the interval timer.
- Press SYSTEM RESET.
- Set the RATE switch to SINGLE CYCLE.
- Enter 1000 (hexadecimal) in STORAGE DATA keys.
- Flip up the STORAGE STATS switch.
- Set RATE switch to PROCESS.
- Set DIAGNOSTIC CONTROL switch to MS ADDRESS.
- Press START. The microprogram light should come on when main storage is cleared. If any other red lights are on, main storage is not fully cleared; repeat procedure.
- Turn DIAGNOSTIC CONTROL switch to OFF.
- Press SYSTEM RESET.

HOW TO CLEAR MAIN STORAGE (continued)

On the Model 44

- Depress the SYSTEM RESET key.
- Turn all STORAGE ADDRESS switches and DATA SWITCHES off (up).
- Depress the SET IC key.
- Depress the SYSTEM RESET key.
- Turn on STORAGE ADDRESS switch 30.
- Turn the MS ADDRESS COMPARE switch to LOAD.
- Depress the START key.
- Depress the STOR EXTN switch to clear extension storage.
- Restore the STOR EXTN and MS ADDRESS COMPARE switches to normal.
- Depress the STOP key.

On the Model 50

- Press STOP.
- Hit SYSTEM RESET.
- Set IC to zero.
- Set RATE switch to SINGLE CYCLE.
- Put 0200 in storage data keys.
- Flip ROS REPEAT INSN down.
- Hit START.
- Set RATE switch to PROCESS.
- Flip up all data keys.
- Flip up ROS REPEAT INSN.
- Hit START.
- Hit SYSTEM RESET.
- Hit STORE.

On the Model 65

- Press STOP.
- Flip data keys up.
- Flip down address keys 0, 21, 22.
- Hit SYSTEM RESET.
- Hit ROS TRANSFER.
- Set STORAGE SELECT to LOCAL and then back to MAIN.
- Hit SYSTEM RESET.

On the Model 75

- Press STOP.
- Press SYSTEM RESET.
- Set general purpose register 0 to zeros.
- Set PSW to zeros.
- Set the data switches to 90 in first byte, 01 in second.
- Flip down ENABLE STORAGE RIPPLE.
- Flip up all other switches.
- Press LOAD A-B REGS.
- Hit START.
- Hit SYSTEM RESET.
- Flip up ENABLE STORAGE RIPPLE.

HOW TO CLEAR MAIN STORAGE (continued)

On the Model 91/95

- Press STOP.
- Hit CLEAR CBR.
- Hit CLEAR CAR.
- Put STORAGE TEST switch EMS ONLY - BOTH - MWS ONLY in appropriate position.
- Put STORAGE TEST switch STORE - OFF - FTH in the STORE position.
- Hit START STOR TEST key.
- To stop operation put STORAGE TEST switch STORE - OFF - FTH to the OFF position.

On the Model 145 and 155

- Hold the ENABLE SYSTEM CLEAR key in the operated position.
- Press the SYSTEM RESET or LOAD key.

On the Model 165

- Hold SYSTEM CLEAR; press SYSTEM RESET.
- Release SYSTEM CLEAR; manual light turns on.
- Perform IPL.

HOW TO DISPLAY A GENERAL PURPOSE REGISTER (GPR)

On the Model 20

- Proceed as in displaying the current PSW except dial in the correct GPR (8 thru F) to be displayed in DATA SWITCH 1.

On the Model 25

- Press STOP.
- Set MODE switch to the AS DATA position.
- Set console switches A and B to 00.
- Set console switch C from 0 to F to display GPR's 0-15.
- Set console switch D to 0 or 2 to display the left halfword or the right halfword of the GPR selected by console switch C.
- Depress DISPLAY key.
- The proper halfword of the selected GPR will be displayed in the BYTE 0 and BYTE 1 indicators.

On the Model 30

- Machine must be in manual mode.
- Set switch A to LS.
- Set switch B to zero.
- Set switch C to desired GPR.
- Set STORAGE SELECT switch E to AS position with red flag up.
- Set switch D to correspond to desired byte of GPR - that is, to 0, 1, 2, or 3.
- Press DISPLAY. The data is displayed in the main storage data register.

On the Model 40

- Set STORAGE SELECT switch to GP.
- Enter into the storage address bank of keys labeled REGISTER SELECT the number in binary of the register desired, and the specific half-word desired in the portion marked HALF-WORD.
- Press DISPLAY. The half-word will be displayed in the storage data lights.

On the Model 44

- Depress the STOP key.
- Turn the STORAGE SELECT switch to GPR.
- Operate the STORAGE ADDRESS switches for the desired GPR (binary code in the low-order four digits).
- Depress the DISPLAY key.

HOW TO DISPLAY A GENERAL PURPOSE REGISTER (GPR) (continued)

On the Model 50

There are four "sectors" in local storage:

- 00 - Channel Sector
- 01 - Working Sector
- 10 - Floating Point Registers (FPR)
- 11 - General Purpose Registers (GPR)

The machine must be in manual mode in order to display any sector of local storage.

- Put sector number to be displayed in address keys 22 and 23.
- Put register to be displayed in address keys 24-27.
- Set STORAGE SELECT to LOCAL.
- Press DISPLAY.
- Rotate roller 3 (CPU 1) to position 1 (L register). The contents of the specified location in local storage is now displayed in the L register.
- To resume processing, press start key. Manual light goes off.

On the Model 65

- Set STORAGE SELECT to LOCAL.
- Put GPR number in address keys 20-23.
- Hit DISPLAY. The contents of the register will be displayed in the T register - position 3 of roller 2.

On the Model 75

- Set STORAGE SELECT to GP REGS.
- Put the register number in the REGISTER SELECT keys.
- Hit DISPLAY. The left word of RBL REG will show the contents of the GPR. The right word will be blank with parity bits on.
- To display an FPR, set STORAGE SELECT to FP REGS and proceed as for GPR.

On the Model 91/95

- Set STORE/DISPLAY switch to the GEN REGS position.
- Put the register number in address keys (CAR) positions 28-31.
- Hit DISPLAY. CBR positions 0-31 will show the contents of the GPR.

On the Model 145 and 155

Refer to Alter/Display Operations on the Model 145 and 155 (page 27).

On the Model 165

- Press STOP.
- Set CRT MODE SELECT to CE and MANUAL ENTRY SELECT to M CAR.
- Set STORAGE SELECT to GEN PUR.
- Press \Rightarrow until cursor underscores high-order (leftmost) byte in M CAR.
- Select the register: enter two digits via data keys. (If error is made, press \Rightarrow until wraparound, then return to desired byte and enter correct data.)
- Press DISPLAY. See the fullword desired at the right-half of MCDR on the CRT.
- To resume, set CRT MODE SELECT to OP and press START.

HOW TO ALTER A GENERAL PURPOSE REGISTER (GPR)

On the Model 20

- Proceed as in altering the current PSW except dial in the correct GPR (8 thru F) to be displayed in DATA SWITCH 1.

On the Model 25

- Do a display function to the GPR to be altered.
- Set desired data into console switches A, B, C, and D.
- Depress the STORE key.

On the Model 30

- Follow same procedure as in displaying a register.
- Put the data you wish to enter into the storage data portion of the keys.
- Press STORE.

On the Model 40

- Follow same procedure as in displaying a register.
- Put data in storage data keys.
- Press STORE.

On the Model 44

- Depress the STOP key.
- Turn the STORAGE SELECT switch to GPR.
- Place GPR address in the STORAGE ADDRESS switches.
- Place data in the DATA SWITCHES.
- Depress the STORE key.

On the Model 50

- Machine must be in manual mode.
- Put sector number in address keys 22 and 23.
- Put word to be stored into in address keys 24-27.
- Set STORAGE SELECT to LOCAL.
- Put data in the data keys.
- Press STORE.

On the Model 65

Proceed as in displaying a register but:

- Put in the bottom bank of data keys the data you wish to store.
- Hit STORE.

HOW TO ALTER A GENERAL PURPOSE REGISTER (GPR) (continued)

On the Model 75

To alter a GPR proceed as in displaying and:

- Put data into the left half of the data keys.
- Hit STORE.

To alter a FPR proceed as in displaying and:

- Put data into the data keys. Put the characteristic in the 0 byte; when you display the FPR, the characteristic will be in Byte 7.
- Hit STORE.

On the Model 91/95

To alter a GPR proceed as in displaying and:

- Put data into CBR positions 0-31.
- Hit STORE.

On the Model 145 and 155

Refer to Alter/Display Operations on the Model 145 and 155 (page 27).

On the Model 165

- Press STOP.
- Set CRT MODE SELECT to CE and MANUAL ENTRY SELECT to MCAR.
- Set STORAGE SELECT to GEN PUR.
- Press \Rightarrow until cursor underscores high-order (leftmost) byte in MCAR.
- Select the register: enter two digits via data keys. (If error is made, press \Rightarrow until wraparound, then return to desired byte and enter correct data.)
- Press DISPLAY. See the fullword desired at the right-half of MCDR on the CRT.
- Check that the \Rightarrow underscores high-order byte.
- Enter desired data via data keys. (If error is made, press \Rightarrow until wraparound, then return to desired byte and enter correct data.)
- When the right-half of MCDR shows desired data (four bytes), press STORE. To verify, press DISPLAY.
- To resume, set CRT MODE SELECT to OP and press START.

STOP ON MAIN STORAGE ADDRESS

On the Model 20

- Press STOP.
- Set MODE switch to the ADDRESS STOP position.
- Set the stop address in switches E, S, T, and R.
- Depress START key.

On the Model 25

- Press STOP.
- Set the address to be stopped at in console switches A, B, C, and D.
- Set MODE switch to MS ADR STOP position.
- Depress START KEY.
- When desired address is reached the machine will stop with the ADR MATCH light on under CPU STATUS.

On the Model 30

- Put the address you wish to stop on in address switches A, B, C, and D.
- Put ADDRESS COMPARE switch on SAR DELAYED STOP.
- The CPU status MATCH indicator will come on when the address is reached.

On the Model 40 (Not effective during IPL)

- Put the address you wish to stop on in the storage address keys.
- Turn ADDRESS COMPARE to MS STOP.

On the Model 44

- Depress STOP key.
- Place stop address in the STORAGE ADDRESS switches.
- Set MS ADDRESS COMPARE switch to STOP.
- Depress START key -- the machine will stop at the end of the instruction that accesses the selected address.

STOP ON MAIN STORAGE ADDRESS (continued)

On the Model 50

Do not perform the following steps while a program is executing.

- Put address to be stopped on in the address keys.
- Set IAR switch to STOP.
- The instruction pointed to by the address keys will be executed and the next address in the program will be displayed in the IAR.
- If the instruction pointed to by the address keys is a branch instruction and the branch is taken, the address of the branch instruction will be displayed in the IAR.

On the Model 65

- Put the address to stop on in the address keys.
- Flip down the ADDRESS COMPARE STOP switch.
- Press START.

On the Model 75

- Put address to be stopped on in the address keys.
- Flip down the ADDRESS COMPARE STOP switch.
- Press START.

On the Model 91/95

- Put address to be stopped on in the address keys (CAR).
- Put ADDRESS COMPARE switch to the INSN position in the CPC HARD STOP range.
- Put CYCLIC PROGRAM COUNTER ENTRY switches to a value of zero.
- Press START.

On the Model 145 and 155

- Press the STOP key.
- Set ADDRESS COMPARE switch to the I COUNTER position.
- Put address to be stopped on in the console switches CDEFGH.
- Set the ADDRESS COMPARE CONTROL toggle switch to the STOP position.
- Press the START key.

On the Model 165

- Press STOP.
- Set CRT MODE SELECT to CE.
- Set ADDRESS COMPARE/SYNC to IC.
- Set STOP ON COMPARE (MS) to STOP.
- Set CS/MS to MS.
- Set MANUAL ENTRY SELECT to MRAR.
- Press → until cursor underscores second byte in MRAR. Enter six-digit-hex stop address via data keys. (If error is made, press → until wraparound, then return to desired byte and enter correct data.)
- To resume, set CRT MODE SELECT to OP and press START.

POWER-ON PROCEDURE

1. Before depressing power-on, insure that all preparation has been completed and that no one is involved in manual manipulations with any machinery attached to the system.
2. Depress power on push button.
3. The length of time required by the system to complete its automatic cycling up process depends on the type system and the number of devices attached to it.
4. Do not attempt any operation until the power on push button has a white glow. This indicates that the system is completely powered up and ready for use.
5. If some of the devices attached fail to power up, an IBM representative should be notified.

Note: For Models 65, 75 and 91/95

Before the power up cycle is complete the power on push button should have a red glow. This should indicate that the system is not ready for use yet.

POWER-OFF PROCEDURE

1. In preparation to turn power off:
 - a. Depress system reset push button.
 - b. Unload all disk and tape drives.
 - c. Open or disengage the print unit release lever on all 1403's.
2. Depress the power off push button.
3. Some devices may not go off in which case the CE should be notified.

HOW TO RECORD THE ROS (READ ONLY STORAGE) ADDRESS

Note: The only time that the ROS address may be accurately recorded is when the ROS unit has stopped. To accomplish this it is advisable to set the rate switch to the single cycle position.

On the Model 30

- Record the hexadecimal value of the W register and the X register. These registers are shown in the read only storage area of the main console in the upper right section.

On the Model 40

- Insure that the display switch (located just below the emergency off knob) is in its center position.
- Record the hex value found in the "ROBAR-ROSAR-ROAR-ROSCAR" indicators (located just beneath and to the left of the display switch).

On the Model 50

- The current ROS address is indicated on roller number 4 (labeled CPU2), roller position 7.
- The previous ROS address is indicated on the same roller described in the previous step except at roller position 8.

On the Model 65

- Roller number one, position number 4 indicates the ROS address, ROS previous address A and ROS previous address B. Each one of these is 3 hex bytes long and should all be recorded (see section V of this manual for a definition of "hex byte").
- Roller number three, position number 4 has one light whose status should be recorded. It is the second from the right, and is labeled "PREV ADR A". Simply record whether it is on or off.

TO CALL IBM FOR SERVICE

1. First check to see if there is a CE on site.
2. If not call your local IBM dispatch at:
Normal IBM Branch Office hours _____.
Outside of Normal Office hours _____.
3. Give dispatch the following information:
 1. Your company name, your name and extension.
 2. Type of machine (box) that gives the error indications.
 3. Type of system attached to (Mod 30, Mod 65, etc.)
 4. What is your urgency?
 5. If known, is your trouble hardware or software.
 6. Any special instructions a CE might need to know to get to your account.
 7. The CE that normally services your Account.
CE NAME--_____.

CODE CHARTS

EXTENDED IBM CARD CODE TO HEXADECIMAL

	Bl	T	E	O	TEO	TE	TO	EO
	(Zones)							
Bl	40	50	60	F0	70	6A	C0	D0
1	F1	C1	D1	61	B1	91	81	A1
2	F2	C2	D2	E2	B2	92	82	A2
3	F3	C3	D3	E3	B3	93	83	A3
4	F4	C4	D4	E4	B4	94	84	A4
5	F5	C5	D5	E5	B5	95	85	A5
6	F6	C6	D6	E6	B6	96	86	A6
7	F7	C7	D7	E7	B7	97	87	A7
8	F8	C8	D8	E8	B8	98	88	A8
9	F9	C9	D9	E9	B9	99	89	A9
18	79	49	59	69	B0	90	80	A0
28	7A	4A	5A	E0	BA	9A	8A	AA
38	7B	4B	5B	6B	BB	9B	8B	AB
48	7C	4C	5C	6C	BC	9C	8C	AC
58	7D	4D	5D	6D	BD	9D	8D	AD
68	7E	4E	5E	6E	BE	9E	8E	AE
78	7F	4F	5F	6F	BF	9F	8F	AF
19	31	01	11	21	71	51	41	E1
29	32	02	12	22	72	52	42	62
39	33	03	13	23	73	53	43	63
40	34	04	14	24	74	54	44	64
59	35	05	15	25	75	55	45	65
69	36	06	16	26	76	56	46	66
79	37	07	17	27	77	57	47	67
89	38	08	18	28	78	58	48	68
189	39	09	19	29	30	10	00	20
289	3A	0A	1A	2A	FA	DA	CA	EA
389	3B	0B	1B	2B	FB	DB	CB	EB
489	3C	0C	1C	2C	FC	DC	CC	EC
589	3D	0D	1D	2D	FD	DD	CD	ED
689	3E	0E	1E	2E	FE	DE	CE	EE
789	3F	0F	1F	2F	FF	DF	CF	EF

Bl = Blank
 T = Twelve
 E = Eleven
 O = Zero

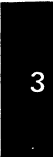

PROGRAM STATUS WORD

System Mask*	Key	AMWP*	Interruption Code
0	7 8	11 12	15 16
			23 24
			31

ILC	CC	Prog. Mask*	Instruction Address
32	33 34 35 36	39 40	47 48
			55 56
			63

0	Multiplexer channel mask	13	Machine check mask (M)
1	Selector channel 1 mask	14	Wait state (W)
2	Selector channel 2 mask	15	Problem state (P)
3	Selector channel 3 mask	32-33	Instruction Length code (ILC)
4	Selector channel 4 mask	34-35	Condition code (CC)
5	Selector channel 5 mask	36	Fixed-point overflow mask
6	Selector channel 6 mask	37	Decimal overflow mask
7	External mask	38	Exponent underflow mask
12	ASCII mode (A)	39	Significance mask

*A one-bit equals on, and permits an interrupt.

CODE FOR PROGRAM INTERRUPTION

Interruption Code			Program Interruption Cause
DEC	HEX	BINARY	
1	01	0000 0001	Operation
2	02	0000 0010	Privileged operation
3	03	0000 0011	Execute
4	04	0000 0100	Protection
5	05	0000 0101	Addressing
6	06	0000 0110	Specification
7	07	0000 0111	Data
8	08	0000 1000	Fixed-point overflow
9	09	0000 1001	Fixed-point divide
10	0A	0000 1010	Decimal overflow
11	0B	0000 1011	Decimal divide
12	0C	0000 1100	Exponent overflow
13	0D	0000 1101	Exponent underflow
14	0E	0000 1110	Significance
15	0F	0000 1111	Floating-point divide

PERMANENT STORAGE ASSIGNMENT

DEC	ADDRESS HEX	BINARY	LENGTH	PURPOSE
0	0	0000 0000	double-word	Initial program loading PSW
8	8	0000 1000	double-word	Initial program loading CCW1
16	10	0001 0000	double-word	Initial program loading CCW2
24	18	0001 1000	double-word	External old PSW
32	20	0010 0000	double-word	Supervisor call old PSW
40	28	0010 1000	double-word	Program old PSW
48	30	0011 0000	double-word	Machine-check old PSW
56	38	0011 1000	double-word	Input/output old PSW
64	40	0100 0000	double-word	Channel status word
72	48	0100 1000	word	Channel address word
76	4C	0100 1100	word	Unused
80	50	0101 0000	word	Timer (uses bytes 50, 51 & 52)
84	54	0101 0100	word	Unused
88	58	0101 1000	double-word	External new PSW
96	60	0110 0000	double-word	Supervisor call new PSW
104	68	0110 1000	double-word	Program new PSW
112	70	0111 0000	double-word	Machine-check new PSW
120	78	0111 1000	double-word	Input/output new PSW
128	80	1000 0000	(1)	Diagnostic scan-out area

(1) The size of the diagnostic scan-out area depends on the particular model and I/O channels; for models 30 through 75, maximum size is 256 bytes.

CONDITION CODE SETTING

	0	1	2	3
FLOATING-POINT ARITHMETIC				
Add Normalized S/L	zero	< zero	> zero	overflow
Add Unnormalized S/L	zero	< zero	> zero	overflow
Compare S/L (A:B)	equal	A low	A high	--
Load and Test S/L	zero	< zero	> zero	--
Load Complements S/L	zero	< zero	> zero	--
Load Negative S/L	zero	< zero	--	--
Load Positive S/L	zero	--	> zero	--
Subtract Normalized S/L	zero	< zero	> zero	overflow
Subtract Unnormalized S/L	zero	< zero	> zero	overflow
FIXED-POINT ARITHMETIC				
Add H/F	zero	< zero	> zero	overflow
Add Logical	zero, not carry	not zero, not carry	zero carry	not zero, carry
Compare H/F (A:B)	equal	A low	A high	--
Load and Test	zero	< zero	> zero	--
Load Complement	zero	< zero	> zero	overflow
Load Negative	zero	< zero	--	--
Load Positive	zero	--	> zero	overflow
Shift Left Double	zero	< zero	> zero	overflow
Shift Left Single	zero	< zero	> zero	overflow
Shift Right Double	zero	< zero	> zero	--
Shift Right Single	zero	< zero	> zero	--
Subtract H/F	zero	< zero	> zero	overflow
Subtract Logical	--	not zero, not carry	zero, carry	not zero, carry
DECIMAL ARITHMETIC				
Add Decimal	zero	< zero	> zero	overflow
Compare Decimal (A:B)	equal	A low	A high	--
Subtract Decimal	zero	< zero	> zero	overflow
Zero and Add	zero	< zero	> zero	overflow
LOGICAL OPERATIONS				
AND	zero	not zero	--	--
Compare Logical (A:B)	equal	A low	A high	--
Edit	zero	< zero	> zero	--
Edit and Mark	zero	< zero	> zero	--
Exclusive OR	zero	not zero	--	--
OR	zero	not zero	--	--
Test Under Mask	zero	mixed	--	one
Translate and Test	zero	incomplete	complete	--
INPUT/OUTPUT OPERATIONS				
Halt I/O	not working	halted	stopped	not oper
Star I/O	available	CSW stored	busy	not oper
Test Channel	not working	CSW ready	working	not oper
Test I/O	available	CSW stored	working	not oper

INPUT/OUTPUT

CHANNEL ADDRESS WORD

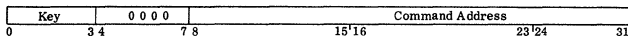

CHANNEL COMMAND WORD

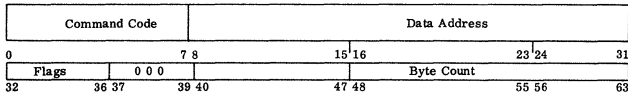

Refer to OPERATION CODE tables for flag bit (Bits 32-36) assignments.

Bit 32 causes the address portion of the next CCW to be used.

Bit 33 causes the command code and data address in the next CCW to be used.

Bit 34 causes a possible incorrect length indication to be suppressed.

Bit 35 suppresses the transfer of information to main storage.

Bit 36 causes an interruption as Program Control Interrupt.

CHANNEL STATUS WORD

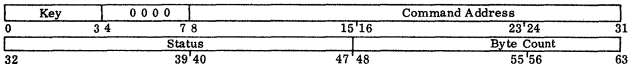

32 Attention	36 Channel end	40 Program - controlled interruption	43 Protection check
33 Status modifier	37 Device end	41 Incorrect length	44 Channel data check
34 Control unit end	38 Unit check	42 Program check	45 Channel control check
35 Busy	39 Unit exception	44 Channel data check	46 Interface control check
		46 Interface control check	47 Chaining check

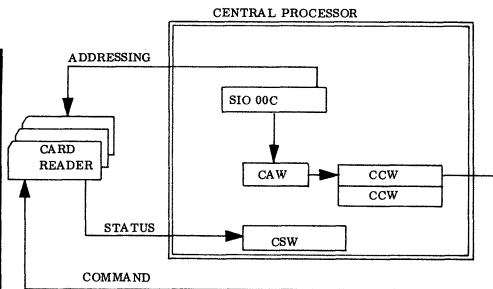

1. The start I/O instruction selects an I/O Device and causes the central processor to look at the Channel Address Word. (CAW)
2. The Channel Address Word tells the Central Processor where in storage it can find the Command (CCW) to be performed on the selected device.
3. At the end of the I/O operation the device causes its status to be stored in a fixed location in storage which is called the Channel Status Word (CSW).

DASD CHANNEL COMMAND CODES (See A26-5988)

Command for CCW		Count	Multiple Track (M-T) Off		M-T On †
			8-Bit Code 0123 4567	Hex Dec	Hex Dec
Control	No Op	X	0000 0011	03 03	
	Seek	6	0000 0111	07 07	
	Seek Cylinder	6	0000 1011	0B 11	
	Seek Head	6	0001 1011	1B 27	
	Set File Mask	1	0001 1111	1F 31	
	Space Count	X	0000 1111	0F 15	
	Transfer in Channel	X	XXXX 1000	X8	
	Recalibrate (2311 only)		0001 0011	13 19	
	Restore (2321 only)	X	0001 0111	17 23	
	Sense I/O	4	0000 0100	04 04	
Sense					
Switching	Release Device	X	1001 0100	94 148	
	Reserve Device	X	1011 0100	B4 180	
Search †	Home Address EQ	4 (usually)	0011 1001	39 57	B9 185
	Identifier EQ	5 (usually)	0011 0001	31 49	B1 177
	Identifier HI	5 (usually)	0101 0001	51 81	D1 209
	Identifier EQ or HI	5 (usually)	0111 0001	71 113	F1 241
	Key EQ	1 to 255	0010 1001	29 41	A9 169
	Key HI	1 to 255	0100 1001	49 73	C9 201
	Key EQ or HI	1 to 255	0110 1001	69 105	E9 233
	Key & Data EQ*		0010 1101	2D 45	AD 173
	Key & Data HI*		0100 1101	4D 77	CD 205
	Key & Data EQ or HI*		0110 1101	6D 109	ED 237
	Continue Scan EQ*	Note 1	0010 0101	25 37	
	Continue Scan HI*		0100 0101	45 69	
	Continue Scan EQ or HI*		0110 0101	65 101	
	Continue Scan No Compare*		0101 0101	55 85	
Continue Scan Set Compare*		0111 0101	75 117		
Read †	Home Address	5	0001 1010	1A 26	9A 154
	Count	8	0001 0010	12 18	92 146
	Record R0	Number of bytes trans- ferred	0001 0110	16 22	96 150
	Data		0000 0110	06 06	86 134
	Key & Data		0000 1110	0E 14	8E 142
	Count, Key & Data		0001 1110	1E 30	9E 158
Initial Program Load (IPL)		0000 0010	02 02		
Write	Home Address	5 (usually)	0001 1001	19 25	
	Record R0	8+KL+DL of R0	0001 0101	15 21	
	Count, Key & Data	8+KL+DL	0001 1101	1D 29	
	Special Count, Key & Data*	8+KL+DL	0000 0001	01 01	
	Data	DL	0000 0101	05 05	
	Key & Data	KL & DL	0000 1101	0D 13	

* Special Feature Note 1. Includes mask bytes in search argument.

† M-T On = M-T Off except, during Search and Read bit 0 = 1 in M-T On.

X = not significant; KL = Key Length DL = Data Length; EQ = Equal; HI = High

CHANNEL COMMAND CODES

Device	Command for CCW		8-Bit Code							Hex	Dec																																																																								
			0	1	2	3	4	5	6			7																																																																							
2540	Read, Feed, Select Stacker SS		Type AA	S	S	D	0	0	0	1	0																																																																								
	Read		Type AB	1	1	D	0	0	0	1	0																																																																								
	Read, Feed (1400 compatibility mode only)			1	1	D	1	0	0	1	0																																																																								
	Feed, Select Stacker SS		Type BA	S	S	1	0	0	0	1	1																																																																								
	PFR Punch, Feed, Select Stacker SS		Type BA	S	S	D	0	1	0	0	1																																																																								
	Punch, Feed; Select Stacker SS		Type BB	S	S	D	0	0	0	0	1																																																																								
	<table border="1" style="display: inline-table; margin-right: 20px;"> <tr><th>SS</th><th>Stacker</th></tr> <tr><td>00</td><td>R1</td></tr> <tr><td>01</td><td>R2</td></tr> <tr><td>10</td><td>RP3</td></tr> </table> <table border="1" style="display: inline-table;"> <tr><th>D</th><th>Data Mode</th></tr> <tr><td>0</td><td>EBCDIC</td></tr> <tr><td>1</td><td>Column Binary</td></tr> </table>		SS	Stacker	00	R1	01	R2	10	RP3	D	Data Mode	0	EBCDIC	1	Column Binary																																																																			
	SS	Stacker																																																																																	
	00	R1																																																																																	
	01	R2																																																																																	
10	RP3																																																																																		
D	Data Mode																																																																																		
0	EBCDIC																																																																																		
1	Column Binary																																																																																		
1442 N1	Read	0 0 X	Eject and SS1	Read	M	M	M	0	0	0	1	0																																																																							
	Read	1 0 X	Eject and SS1	Write	M	M	M	0	0	0	0	1																																																																							
	Read	0 1 X	Eject and SS2	Control	M	M	0	0	0	0	1	1																																																																							
	Read	1 1 X	Eject and SS2	No Op	0	0	0	0	0	0	1	1																																																																							
	Write	0 0 X	SS1	Sense	0	0	M	M	0	1	0	0																																																																							
	Write	1 0 X	Eject and SS1																																																																																
	Write	0 1 X	SS2																																																																																
	Write	1 1 X	Eject and SS2																																																																																
	Control	1 0	Eject and SS1																																																																																
	Control	0 1	SS2																																																																																
	Control	1 1	Eject and SS2																																																																																
	Sense		1 1	Punch diagnostic																																																																															
	Sense		0 1	Read diagnostic																																																																															
	X = 0 means EBCDIC mode																																																																																		
	X = 1 means Column Binary Mode																																																																																		
1403 or 1443	Write, No Space			0	0	0	0	0	0	0	1	0	01	01																																																																					
	Write, Space 1 After Print			0	0	0	0	1	0	0	0	1	09	09																																																																					
	Write, Space 2 After Print			0	0	0	1	0	0	0	1	1	11	17																																																																					
	Write, Space 3 After Print			0	0	0	1	1	0	0	1	1	19	25																																																																					
	Write, Skip To Channel N After Print			1	C	H	A	N	0	0	1																																																																								
	Diagnostic Read (1403)			0	0	0	0	0	0	1	0	0	02	02																																																																					
	Diagnostic Read (1443)			0	0	0	0	0	1	1	0	0	06	06																																																																					
	Test I/O			0	0	0	0	0	0	0	0	0	00	00																																																																					
	Sense			0	0	0	0	0	1	0	0	0	04	04																																																																					
	Carriage Control	Space 1 Line Immediately			0	0	0	0	1	0	1	1	1	0B	11																																																																				
Space 2 Line Immediately			0	0	0	1	0	0	1	1	1	13	19																																																																						
Space 3 Line Immediately			0	0	0	1	1	0	1	1	1	1B	27																																																																						
Skip To Channel N Immediately			1	C	H	A	N	0	1	1	1																																																																								
No Op			0	0	0	0	0	0	1	1	1	03	03																																																																						
<table border="1" style="display: inline-table; margin-right: 20px;"> <tr><th>C</th><th>H</th><th>A</th><th>N</th><th>Channel</th></tr> <tr><td>0</td><td>0</td><td>0</td><td>1</td><td>1</td></tr> <tr><td>0</td><td>0</td><td>1</td><td>0</td><td>2</td></tr> <tr><td>0</td><td>0</td><td>1</td><td>1</td><td>3</td></tr> <tr><td>0</td><td>1</td><td>0</td><td>0</td><td>4</td></tr> <tr><td>0</td><td>1</td><td>0</td><td>1</td><td>5</td></tr> <tr><td>0</td><td>1</td><td>1</td><td>0</td><td>6</td></tr> </table> <table border="1" style="display: inline-table;"> <tr><th>C</th><th>H</th><th>A</th><th>N</th><th>Channel</th></tr> <tr><td>0</td><td>1</td><td>1</td><td>1</td><td>7</td></tr> <tr><td>1</td><td>0</td><td>0</td><td>0</td><td>8</td></tr> <tr><td>1</td><td>0</td><td>0</td><td>1</td><td>9</td></tr> <tr><td>1</td><td>0</td><td>1</td><td>0</td><td>10</td></tr> <tr><td>1</td><td>0</td><td>1</td><td>1</td><td>11</td></tr> <tr><td>1</td><td>1</td><td>0</td><td>0</td><td>12</td></tr> </table>		C	H	A	N	Channel	0	0	0	1	1	0	0	1	0	2	0	0	1	1	3	0	1	0	0	4	0	1	0	1	5	0	1	1	0	6	C	H	A	N	Channel	0	1	1	1	7	1	0	0	0	8	1	0	0	1	9	1	0	1	0	10	1	0	1	1	11	1	1	0	0	12												
C		H	A	N	Channel																																																																														
0		0	0	1	1																																																																														
0		0	1	0	2																																																																														
0		0	1	1	3																																																																														
0	1	0	0	4																																																																															
0	1	0	1	5																																																																															
0	1	1	0	6																																																																															
C	H	A	N	Channel																																																																															
0	1	1	1	7																																																																															
1	0	0	0	8																																																																															
1	0	0	1	9																																																																															
1	0	1	0	10																																																																															
1	0	1	1	11																																																																															
1	1	0	0	12																																																																															

IBM 2400/3420 Magnetic Tape Unit Command Code Format

Command Code Format	0	1	2	3	4	5	6	7	
Write	0	0	0	0	0	0	0	1	
Read	0	0	0	0	0	0	1	0	
Read Backward	0	0	0	0	1	1	0	0	
Sense	R	R	R	R	0	1	0	0	
Control	0	0	C	C	C	1	1	1	(Tape motion operation)
	D	D	M	M	M	0	1	1	(Seven-track mode setting operation)
	1	1	N	N	N	0	1	1	(Nine-track mode setting operation - 2400 Models 4-6. NOP for Models 1-3.)
Data Security Erase (DSE)	1	0	0	1	0	1	1	1	(3803/3420 only)

C	C	C (Control Code)	N	N	N	D	D (Density Set) -- Seven Track Operation Only	
0	0	0 = Rewind (REW)	0	0	0	0	0 = 200 bpi	
0	0	1 = Rewind and Unload (RUN)				0	1 = 556 bpi	
0	1	0 = Erase Gap (ERG)	0	0	1	1	0 = 800 bpi Reset condition	
0	1	1 = Write Tape Mark (WTM)				1	1 = Set Nine-Track Mode - Models 4-6	
1	0	0 = Backspace Block (BSB)	NOTE: Other bit patterns in this group reserved for future use.					
1	0	1 = Backspace File (BSF)						
1	1	0 = Forward Space Block (FSB)						
1	1	1 = Forward Space File (FSF)						

R	R	R	R
1	1	1	1 = Sense Control Unit Reserve (3803 with two-ch sw feature only)
1	1	0	1 = Sense Control Unit Release (3803 with two-ch sw feature only)
0	0	0	0 = Sense Command (All Control Units)

- Notes:**
1. Nine-track operation overrides but does not reset a seven-track mode setting. Seven-track operation overrides but does not reset a nine-track mode setting. Nine-track operations on 2400 Models 1, 2, 3 force 800 bpi and odd parity.
 2. A DSE must follow and be command chained to an ERG. Failure to do so results in command reject.
 3. The 3803 does not write 7-track at 200 bpi (issuing a 200 bpi mode set forces 556 bpi, odd parity).
 4. A sense reserve or sense release command issued to a tape control without the two-channel switch feature results in command reject.
 5. A sense reserve or sense release command must be issued by themselves or be the first command in a chain. Failure to do so results in command reject.

<u>M M M (Mode Modifiers)</u>			Set Density	Set Odd Parity	Set Even Parity	Data Converter On (Note 4)	Data Converter Off	Translator On	Translator Off	Request TIE (Note 3)	
0	0	0	-----								NOP (No Operation) Reserved for Diagnostic use ONLY.
0	0	1	-----								
0	1	0	-----	X	X	X			X		Reset Cond (Note 1)
0	1	1	-----							X	Nine-track NRZI only - Note 5
1	0	0	-----	X		X	X	X			
1	0	1	-----	X		X	X				
1	1	0	-----	X	X		X		X		Reset Cond (Note 2)
1	1	1	-----	X	X		X	X			

X = Condition set on or activated by related mode modifier bit configuration.

- NOTES:
- Reset condition if data converter feature is installed with the seven-track feature. This command will be rejected by control units that have the seven-track feature, but do not have the data converter feature installed. Density, odd parity, and translator off will be set.
 - Reset condition if data converter feature is not installed with the seven-track feature.
 - TIE - Track in error
 - A read backward command overrides data converter on mode set.
 - Request TIE issued to a Model 4, 5, 6 PE or 2415 results in NOP.

MESSAGE FORMAT FOR OS

The exact formats and meanings of individual messages are contained in the publication IBM System/360 Operating System: Messages and Codes, GC28-6631.

A console message from an IBM program is up to 120 characters long and has the following format:

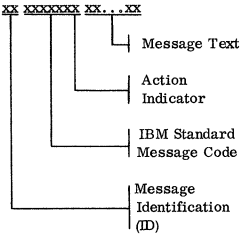

Message Identification (ID)

A 2-character numeric field called the message ID appears to the left of, and is separated by one blank from any message that requires a reply. Use this number with the REPLY command to enable the system to identify the reply. When the message does not require a reply, the message ID does not appear.

The maximum number of IDs, not exceeding 100, is set at the time the system is generated. The system assigns a unique ID to each reply-requesting message.

After processing a REPLY, the ID may be reassigned to another message. If a job ends before you can REPLY to a message, another message is written listing all the message IDs you should ignore.

IBM Standard Message Code

The IBM Standard message code is a unique alphanumeric code of at least six characters assigned to each message written by IBM programs. The code identifies the program that is the source of the message.

For example, codes starting with the following characters identify the programs listed:

<u>Codex</u>	<u>Program</u>
IBC	Independent Utilities
IEA	Supervisor
IEB	Utilities
IEC	Data Management
IEE	Master Scheduler
IEF	Job Scheduler

Action Indicator

The action indicator is a 1-character alphabetic mnemonic that denotes the general class of action required. It appears immediately following the IBM standard message code. It is separated from the message text by at least one blank character.

The following action indicators are defined for System/360 Operating System programs:

- A: An "await action" condition that requires you to perform a specific action before the task will continue. The action is specified either in the message text field or in a supplemental listing. An example of such action is the mounting or required data volumes.
- D: An "await decision" condition that requires you to choose between alternative courses of action. For example, if a job requires more input/output devices than are currently available, you can either vary a device or cancel the job.
- E: Eventual action; operator must perform action when he has time.
- I: An information message that does not require immediate action. For example, this type of message could be used to indicate that a certain control program phase has been completed, or that certain tape units are now available for the mounting of new volumes.
- W: A "cannot proceed" condition that stops processing until the action to be taken is determined, and this action is performed. For example, this condition could be caused by a suspected machine malfunction requiring investigation by the Customer Engineer.
- S: A "cannot proceed" condition caused by a hardware malfunction that cannot be corrected by retry. Run the standard, stand-alone diagnostic program called SEREP, following the procedure given in Chapter 4.

Message Text

The message text is a brief statement of information, a request for action, or a request by the program for information to be supplied.

Internal, Serial Numbers:

You may find internally-generated serial numbers of the form LGLxxx or /xxxxx in the text of messages requesting you to dismount unlabeled tape volumes. If you are asked to retain these volumes, mark them with their internal serial numbers, using any convenient means, such as masking tape and a felt-tipped pen. The system may later ask you to remount the volumes, using their internal serial numbers, in an order different from the one in which they were dismounted.

Input-Output Error Messages

1. IEA000A adr,INT REQ,cm,stat,sensbbbbbb,,ser,jjj
IEA000A adr,INT REQ,CC=3/NO PATHS AVAILABLE,, ,jjj

Explanation:

For the first format of the message, the input/output supervisor detected a device that requires intervention; for the second format of the message, the input/output supervisor received a not operational indication on the last available path to a device.

In the message text in hexadecimal, the fields are:

adr	Unit address of the device.
cm	Operation code of the channel command word (CCW) during whose execution the error occurred. If the channel command word cannot be found, this field appears as **.
stat	Status portion of the channel status word (CSW).
sens	First 2 sense bytes for the error condition.
bbbbbb	Next 3 sense bytes for the error condition. This field appears only for devices that give more than 2 bytes of sense information.
ser	Serial number of the volume on which intervention is required. This field appears only for magnetic tape or direct access devices.
jjj	Job name, in characters, during which intervention is required. (If the job name cannot be determined, this field will be left blank.)

Operator Response:

For the first format of the message, take an appropriate action, such as:

- Make the unit ready. If the unit cannot be made ready, cancel the job.
- Feed more cards to the reader or punch.
- Clear a card jam.
- Empty a stacker.
- Empty the chip box.
- Put paper into the printer or console typewriter.

For the second format of the message, either physically turn on a path to the device (for example, a control unit switch or a channel switch) or VARY a path online that has been previously varied offline. Then, if necessary, make the device ready.

If the above action does not result in continuation of system operation, do the following before calling IBM:

- Execute the IMDSADMP service aid program, specifying the TYPE=HI option, to produce a storage dump to tape. If a tape is not available, execute the IMDSADMP program with TYPE=LO option to produce a dump to the printer.
- Execute the IMDPRDMP service aid program with the 'GO' option after restarting the system. The input to IMDPRDMP is the dump tape from IMDSADMP. Save the formatted dump output.

2. IEA000I adr, errmsg, cm, stat, sensbbbbbb, dcbctfd, ser, jjj
IEA000I lna, errdscrptn, cm, stat, ibss, opxxterm, , jjj
IEA000I adr, errdscrptn, cm, stat, sensbbbbbb,
 { binxcylntreck, ser, jjj
 { binxsbstcytr }
 dcbctfd }

Explanation

The input/output supervisor, the basic telecommunication access method (BTAM), or the queued telecommunication access method (QTAM) routine found an uncorrectable input/output error. The first format of the message is used only for magnetic tapes; the second format only for telecommunication devices; and the third format for all devices other than telecommunication devices.

In the message texts, the fields are:

errmsg

Message describing the error:

- ERASE G-CONTINUE to indicate that a data check occurred during an erase gap operation. The operation was initiated by the write recovery procedures. This message is an indication that some residual data remained on the tape; a later reread through the erased area may indicate a noise record. Depending on the length of the noise, a permanent error (read data check) may occur.
- NOISE-FIRST RETRY to indicate that a noise record (a record whose length is less than 12 bytes) was recognized as a cause of a data check. The noise record is ignored, and no repositioning for a reread is attempted.
- NOISE-ERP IN PROG to indicate that error recovery procedures were in progress when a short record-data check condition was encountered. This situation should not occur, and is a good indication of either faulty hardware media, a crimp in the tape, or noise on the bus line. Repositioning of the tape cannot be guaranteed under these conditions.

errdscrip

Description of the error based on status and sense information:

- CHAN CTL CK - channel control check.
- INTF CTL CK - interface control check.
- CHAIN CHECK - chaining check.
- CHAN DATA CK - channel data check.
- EQUIP CHECK - equipment check.
- BUS OUT CK - bus out check.
- CMD REJECT - command reject.
- DATA CHECK
- SNS I/O MALF - a unit check occurred during a sense operation. (When this condition is present, the fields cm, stat, sensbbbbbb, and binxcylntreck do not appear in the message text.)
- OVERRUN - (for direct access and magnetic tape only).
- SEEK CHECK - (for direct access only).
- NO REC FOUND - no record found (for direct access only).
- MISSING A. M. - missing address marker (for direct access only).
- DATA CONV CK - data converter check (for magnetic tape only).
- UNUSUAL CMD - unusual command (for 2540 card reader and punch only).
- TIMEOUT - (for telecommunications only).
- LOST DATA - (for telecommunications only).
- I/O ERR - input/output error (for errors other than those described above).

adr

Unit address, in hexadecimal, of the device.

lna

Line address, in hexadecimal.

cm

Command code, in hexadecimal, of the channel command word (CCW) being executed when the error occurred. If the channel command word cannot be found, this field appears as **.

stat

Status portion, in hexadecimal, of the channel status word (CSW).

sens

First two sense bytes, in hexadecimal, for the error condition. This field appears only if a unit check condition is indicated in the stat field (which precedes this field in the message text).

bbbbbb

Next three sense bytes, in hexadecimal, for the error condition. This field appears only for devices that give more than two bytes of sense information.

ib

The sense byte describing a unit check type error condition for telecommunication devices.

ss

Sense information resulting from the execution of a diagnostic Write/Read command which ended with a unit check status (2701 Data Adapter Unit only). This information may result from a Write/Break or Read/Skip command for QTAM.

dcbtffd

Record count, in hexadecimal, not including label records. This field appears only for magnetic tape. (For the first format of this message, this field indicates the count of the record preceding the error record.)

op

TP operation code, in hexadecimal, describing the type of channel command word (CCW) being executed when the error occurred.

xx

Not used.

term

Terminal identification characters, in hexadecimal. It may be either two bytes or one byte, depending upon the terminal type. If it is one byte, it is left justified. If a dial line is being used with QTAM, the last four digits of the dial number are provided.

binxcyltrck

Address, in hexadecimal, of the bin (binx), the cylinder (cyl), and the track (trck) where the error occurred. When an error occurs while trying to obtain this data, the last seek address is substituted. This field appears only for disk and drum direct access devices.

binxsbstcyr

Address, in hexadecimal, of the bin (binx), the subcell (sb), the strip (st), the cylinder (cy), and the track (tr) where the error occurred. When an error occurs while trying to obtain this data, the last seek address is substituted. This field appears only for data cell direct access storage devices.

ser

Serial number of the volume on which the error occurred. This field appears only for magnetic tape or direct access devices.

jjj

Job name, in characters, during which the error occurred. If the job name cannot be determined, this field will be left blank.

Note:

Two consecutive commas or a blank field in the message text indicate that a field could not be determined.

Operator Response:

Probable hardware error. For the first format of the message, proceed with caution in accepting, unconditionally, the results of the operation. Consider cancelling the job if there is a requirement to expect perfect results. Each message should be considered as a potential warning of a marginal condition. If the problem recurs, do the following before calling IBM for hardware support:

- Have the master console log available.

For the second and third formats of the message, note that some abnormal error condition occurred. Depending on the severity of the error (check the status and sense information) and depending on the installation requirements, take appropriate action.

3. IEA001I UNIT adr, PATH pth INOPERATIVE (FOR CPU x)

Explanation:

One path to a multipath device has become inoperative. The system will continue all operations on a limited basis, using the remaining paths.

In the message text, the fields are:

adr

Unit address, in hexadecimal, of the device.

pth

Channel and unit control path, in hexadecimal, by which the device could not be accessed. If the path cannot be determined, this field appears as **.

x

Central processing unit, A or B, for which the path is inoperative. The field FOR CPU x appears only for multiprocessing systems.

Operator Response:

Probable hardware error. The system will automatically begin reusing the path when it becomes operational. If the problem persists, do the following before calling IBM for hardware support:

- Have the master console log available.

1052 PRINTER-KEYBOARD

	Bit							
	0	1	2	3	4	5	6	7
Write without Carrier Return	0	0	0	0	0	0	0	1
Write with Carrier Return	0	0	0	0	1	0	0	1
Read	0	0	0	0	1	0	1	0
Control Alarm	0	0	0	0	1	0	1	1
No-op	0	0	0	0	0	0	1	1
Test I/O	0	0	0	0	0	0	0	0
Sense	0	0	0	0	0	1	0	0

Status Byte

Bit	Name	Description
0	Attention	Request Button
1	Not Used	
2	Not Used	
3	Busy	
4	Channel End	
5	Device End	
6	Unit Check	Defined by Sense Byte
7	Unit Exception	Read Cancel Button

Sense Byte

Bit	Name	Description
0	Command Reject	Invalid Command
1	Intervention Required	Not Ready
2	Bus-Out Check	Parity Error on Bus Out
3	Equipment Check	Typewriter Parity Error

1442 CARD READ PUNCH

Status Byte

Bit	Name	Description
3	Busy	
4	Channel End	
5	Device End	
6	Unit Check	-- further explained by sense byte
7	Unit Exception	-- EOF and last card has been read

Sense Byte

Bit	Name	Description
0	Command Reject	
1	Intervention Required	-- not ready
2	Bus-Out Check	
3	Equipment Check	-- reader check, punch check, invalid card code punched and data error on CE read or write.
4	Data Check	-- invalid card code on read
5	Overrun Check	

1443 PRINTER

Status Byte

Bit	Name	Description
0, 1, 2	Not Used	
3	Busy	Command stored or status stacked.
4	Channel End	
5	Device End	
6	Unit Check	Channel 9 sensed in carriage tape.
7	Unit Exception	Channel 12 sensed in carriage tape.

Sense Byte

Bit	Names	Description
0	Command reject	Because read-backward command was received, or because more than 3 line spaces were requested, or because skip to channel 0, 13, 14, or 15 was received.
1	Intervention required	Printer not ready because forms check-ran out or jammed, or stop key or carriage stop key pressed, or cover interlock open.
2	Bus-Out Check	Parity error on bus-out during initial selection with command-out tag up, or data transfer with service-out tag up.
3	Equipment Check	Printer malfunction because of buffer register parity error or typebar synchronization error.
4 & 5	Typebar Selection	Changed only by repositioning the typebar-character indicator switch. 0 0 52-character set 0 1 13-character set 1 0 39-character set 1 1 63-character set
6	Channel 9	Hole sensed in channel 9 of carriage control tape during last write or control command.
7	Channel 12	Hole sensed in channel 12 of carriage control tape during last write or control command.

2250-MODEL 1 GRAPHIC DISPLAY UNIT

Summary of Status and Sense Information

<u>Status Byte</u>		<u>Sense Byte 1</u>	
<u>Bit</u>	<u>Name</u>	<u>Bit</u>	<u>Name</u>
0	Attention	0	Light Pen Detect
1, 2	Unused	1	End Order Sequence
3	Busy	2	Character Mode
4	Chan End	3-7	Unused
5	Device Ena		
6	Unit Check	<u>Sense Byte 2</u>	
7	Unused	<u>Bit</u>	<u>Name</u>
<u>Sense Byte 0</u>		0, 1, 2	Unused
<u>Bit</u>	<u>Name</u>	3-7	Hi-order Buffer Address Ctr
0	Command Reject	<u>Sense Byte 3</u>	
1	Intervention Required	<u>Bit</u>	<u>Name</u>
2	Bus Out Check	0-5	Lo-order Buffer Address Ctr
3	Equipment Check	6, 7	Unused
4-7	Unused		

Note: Sense byte 2 and 3 will be zero if the buffer is running when the sense command is issued.

2821 CONTROL UNIT

Status Byte

<u>Bit</u>	<u>Name</u>	<u>Description</u>
0	Not Used	
1	Not Used	
2	Not Used	
3	Busy	
4	Channel End	
5	Device End	
6	Unit Check	Further defined by Sense Byte
7	Unit Exception	Reader--last card Read and Stacked Printer--Channel 12 sensed-- further defined by Sense Byte

Sense Byte

<u>Bit</u>	<u>Name</u>	<u>Description</u>
0	Command Reject	
1	Intervention Required	Not Ready
2	Bus Out Parity	Parity of command on Bus Out
3	Equipment Check	Parity Error in Control Unit or Device
4	Data Check	On Reader Invalid Card Code. On PFR also.
5	UCS Parity	Printer UCS Parity Error.
6		Reader 2 reads no feed. Punch Only PFR. Printer Channel 9.
7		Reader Punch--not used. Printer--Channel 9

2803 TAPE CONTROL

Status Byte

<u>Bit</u>	<u>Name</u>	<u>Description</u>
0	Attention	Not used.
1	Status Modifier	Present with busy to indicate TCU busy.
2	Control Unit End	Signaled by the TCU: (a) At completion of operations during which a TCU busy was indicated. (b) At the completion of a control immediate operation during which a unit check or unit exception is detected.
3	Busy	When presented without bit 1 (status modifier bit), indicates that the tape unit is busy.
4	Channel End	Indicates that a read, read backward, write, mode set or sense has been completed, or that a control command has been accepted.
5	Device End	Indicates that the tape unit has completed operation at TU level of command. Device end indicated with channel end at the completion of command.
6	Unit Check	Set whenever: (a) Any bit is on in sense byte 0. (b) Tape unit performing read backward, backspace record or backspace file into or at load point. (c) A rewind and unload is completed at the TCU level.
7	Unit Exception	Set when: (a) A write, WTM or ERG operation is performed in the end of tape area. (b) A tape mark is sensed during a read, read backward, forward space record, or backspace record.

Bit	Designation	2401-2404, 2415 and 2420 Interpretation	
		Models 1-3 (and Models 4-6, 800 bpi, NRZI Mode)	Models 4-7 (1,600 bpi PE)
0	Command reject	Set when a write, write tape mark, or erase command is addressed to a file protected tape unit, on a data-converter-on control command that is addressed to a seven-track tape unit is recognized on a TCU with the seven-track compatibility feature but without the data converter feature. In this case, mode set is executed for parity, density, and translator.	Same as Models 1-3
1	Intervention required	Set whenever tape unit status A is inactive, i.e., tape unit is not ready or nonexistent. See "Sense Byte 1."	Same as Models 1-3
2	Bus-out check	Set whenever even parity appears on the information bus lines from the channel to the control unit.	Same as Models 1-3
3	Equipment check (excluding 2415) Equipment check (2415)	Set when reject tape unit (bit 1, byte 4) or sequence error (bit 5, 6, or 7 of byte 4) is set. Set whenever C-compare or clock check occurs. See "Sense Byte 3."	Set when reject tape unit (bit 1, byte 4) is set. Same as Models 1-3
4	Data check	Set when a data check occurs. See "Sense Byte 3."	Same as Models 1-3; see "Sense Byte 4."
5	Overrun	Set if service is requested, but data cannot be transferred during a read, write, or read backward operation. Data transfer stops as soon as condition is detected. Note: Data check during overrun suppresses the overrun indication.	Same as Models 1-3
6	Word count zero	Set during a write operation if transfer of data is prevented before the first byte of data. When word count zero is set, no tape motion occurs.	Same as Models 1-3
7	Data converter check	This bit is set when an error occurs during operation of the data conversion feature.	Same as Models 1-3

Sense Byte 1

Bit	Designation	2401-2404, 2415 and 2420 Interpretation	
		Models 1-3 (and Models 4-6, 800 bpi, NRZI Mode)	Models 4-7 (1,600 bpi, PE)
0	Noise (excluding 2415)	<p>During a read forward space block, indicates that data was recognized after the normal LRC byte time but not long enough after to be considered a new block. Data before the LRC byte is checked and transferred; data after the LRC byte turns on the noise bit and maintains tape motion, but is not transferred.</p> <p>When connected to Model 2 control, during a read backward or backspace block, if data is recognized after the disconnect sequence is started. With Model 1 control, data recognized after start of disconnect, is transferred as part of block. Noise bit is not set; data check is probable.</p> <p>During a write, erase gap, or write tape mark, indicates that data (or noise caused by tape defects) was detected at the read head before the block or tape mark was written, or during erase gap while the tape was being erased. Data check and unit check are indicated.</p>	<p>Set during read or read backward if a data check occurs.</p> <p>Same as Models 1-3</p>
0	Noise (2415)	<p>During a write or write tape mark, indicates that data (or noise caused by tape defects) was detected at the read head before the block or tape mark was written.</p>	<p>Same as Models 1-3</p>
1*	TU Status A	Selected and ready.	Same as Models 1-3
2*	TU Status B (non-2415)	Not ready, or rewinding, or under the control of another TCU via the 2816 Switching Unit. Assuming no outstanding device end status, the bits determine response to initial selection as follows:	Same as Models 1-3

2*	TU Status B	Tape Unit Status A	Tape Unit Status B	Tape Unit Status	Response to Initial Selections		
		0	0	Nonexistent	Unit check		
		0	1	Not ready	Unit check, arm for device end		
		1	0	Ready and not rewinding and not switched.*	Clear status		
		1	1	Ready and rewinding or switched or power is down on a tape unit attached through a switching unit.	Busy, arm for device end		
		Note: Unit check is not signaled for a sense operation. Following unit check or busy indication, device end will be signaled when the tape unit becomes ready and not rewinding.					
	(2415)	No references to the 2816 Switching Unit apply.					
3	Seven-track	The selected tape unit has the seven-track feature installed.			Same for 2415 Always 0 for 2401-2402 Models 4-7.		
4	Load point	The selected tape unit is at load point.			Same as Models 1-3		
5	Selected and write status	The selected tape unit is in write status.			Same as Models 1-3		
6	File protect	The selected tape unit is in file protect status.			Same as Models 1-3		
7	Not capable	Not used, always set to zero.			Tape unit and/or control are not compatible with mounted tape (indicated after read from load point).		
* Switched means that the tape unit is selected by some other control unit under control of a tape unit switch.							

Sense Byte 2

2401-2404, 2415 and 2420 Interpretation	
Models 1-3 (and Models 4-6, 800 bpi, NRZI Mode)	Models 4-7 (1,600 bpi, PE)
This sense byte contains the track-in-error indicator bits that are set at the end of a read or read backward command if a data check has been encountered. See "Cyclic Redundancy Check." At the end of a properly executed read or read backward with no data check and at the end of all other commands, sense byte 2 contains at least bits 6 and 7 set to 1's. No error correction is attempted when operating with seven-track tape units; bits 6 and 7 are set to 1's in sense byte 2.	Not applicable
2415: Not applicable; bits 6 and 7 set to 1 unconditionally.	

Sense Byte 3

2401-2404, 2415 and 2420 Interpretation			
Bit	Designation	Models 1-3 (and Models 4-6, 800 bpi, NRZI Mode)	Models 4-7 (1,600 bpi, PE)
0	R/W VRC (2401-4 Models 1-6) Data reg VRC (2415 Models 1-6)	A vertical redundancy check occurred during a read or read backward operation. Indicator is not set after an overrun or after receipt of a stop signal. *	A vertical parity error occurred during read or read backward operation that could not be corrected, or a Model 7 write operation.
1	LRCR (Models 1-3) Multiple Track Error (Models 4-6)	A longitudinal redundancy check occurred during write, write tape mark, read, or read backward operation.	Weak signal in more than one track on a read or read backward operation. Data is incorrect. Also velocity check on write operation.

2	Skew	Excessive skew detected by a read back check during a write, write tape mark, or erase operation.	Excessive skew detected during a read or read backward operation.
3	CRC (Models 1-3) End data check (Models 4-6)	A cyclic redundancy check occurred during a read or read backward operation (nine-track only). 2415: Not applicable.	Set when sync burst following data block is not properly recognized, or is improperly recognized before actual end of data, 2415: Set with false end-of-block indication.
4	Skew reg VRC (Models 1-3) Envelope check (Models 4-6)	A character with incorrect parity detected in skew register during write, write tape mark, or erase operation.	Indicates at least one track with low signal while writing.
4 (2415)	Read reg VRC (Models 1-3) Envelope check (Models 4-6)	A character with incorrect parity detected in read register during write or write tape mark operation.	Indicates at least one track with low signal while writing.
5	Phase encoding	Not applicable; always set to zero.	Selected tape unit is set to PE recording mode.
6	Backward	The selected tape unit is in backward status.	Same as Models 1-3
7	C compare	C compare is a data check. It indicates that parity of data into the register did not equal that out of the data register.	Same as Models 1-3
<p>Note: Bits 0-4 and 7 of byte 3 indicate data checks. Any of these will set data check (bit 4, byte 0). 2415: Bit 7 causes equipment check.</p>			
* Stop signal resulted from halt I/O instruction in CPU.			

Sense Byte 4

Bit	Designation	2401-2404, 2415 and 2420 Interpretation	
		Models 1-3 (and Models 4-6, 800 bpi, NRZI Mode)	Models 4-7 (1,600 bpi, PE)
0	Not used	Same	Same as Models 1-3
1	Reject TU	Selected tape unit failed to respond to set read or set write status when instructed, or became not ready during execution of a tape motion operation. Equipment check (bit 3, byte 0) also set.	Same as Models 1-3
2	Read clock	Maintenance aids	Not used
3	Write clock		Maintenance aid
4	Delay counter		Not used
5	C sequence	These sequence indicators are maintenance aids. They are set only in the event of a machine failure and cause equipment check and unit check. 2415: All zero bits transmitted for sense byte 4.	Set in event of a machine failure and cause a data check and unit check.
6	B sequence		
7	A sequence		

Sense Byte 5

Bit	Designation	2401-2404, 2415 and 2420 Interpretation	
		Models 1-3 (and Models 4-6, 800 bpi, NRZI Mode)	Models 4-7 (1,600 bpi, PE)
0	Reserved for future use	Always zero	Always zero
1	Reserved for CE function		
2-6	None	Always zero	Always zero
7	Reserved for RPQ use	Always zero	Always zero

2841 STORAGE CONTROL

Status Byte

<u>Bit</u>	<u>Name</u>	<u>Note</u>
0	Attention	Not Used
1	Status Modifier	Used with Search and Control Unit Busy.
2	Control Unit End	The control unit has finished an operation.
3	Busy	Indicates addressed access mechanism is moving; or used in conjunction with Status Modifier to indicate Control Unit Busy.
4	Channel End	The control unit has received all the data from the channel needed to do the operation called for and the channel is freed.
5	Device End	Indicates that an access mechanism is free to be used.
6	Unit Check	Indicates that a control unit or programming error or device hardware check has been detected.
7	Unit Exception	End-of-File.

Sense Information Summary

Sense Bit:

<u>Position</u>	<u>Condition</u>
-----------------	------------------

Byte 0

<u>Bit</u>	<u>Condition</u>
------------	------------------

0	Command Reject includes Invalid Command, Invalid Sequence, and File Protected.
1	Intervention Required
2	Bus Out Parity
3	Equipment Check
4	Data Check
5	Overrun
6	Track Condition Check
7	Seek Check

Byte 1

<u>Bit</u>	<u>Condition</u>
------------	------------------

0	Data check in count field; also causes Byte 0, Bit 4 (Data Check) to be turned on.
1	Track Overrun. Indicated on Write.
2	End of Cylinder
3	Invalid Sequence also causes Command Reject (Byte 0, Bit 0) to be turned on.
4	No Record Found
5	File Protected also causes Command Reject (Byte 0, Bit 0)
6	Missing Address Marker
7	Overflow Incomplete

Byte 2

<u>Bit</u>	<u>Condition</u>
------------	------------------

0	Unsafe	} Also turn on Equipment Check Byte 0, Bit 3
1	Not Used	
2	Serializer/Deserializer Check	
3	Not Used	
4	ALU Check	
5	Unselected Status	

2841 STORAGE CONTROL (Continued)
 Sense Information Summary (Continued)

Byte 3

Bit	2311	2321	2302	2303	2314
0	Ready	Drive Ready	Access Ready		Busy
1	On Line	Drive Operative	Access Operative		On Line
2	Unsafe	Read Safety	Read Safety		Unsafe
3	-----	Write Safety	Write Safety		Not Used
4	On Line	Strip Ready	On Line	On Line	Pack Change
5	End of Cylinder	Invalid Address	-----		End of Cylinder
6	-----	Auto Restore	-----		Not Used
7	Seek Incomplete	CE Cell Located	CE Cylinder Located		Seek Incomplete

Byte 4

Module Identification - Sense Byte 4

Four bits in sense byte 4 are used for module identification. These bits are now used on all 2314s. Since each of the nine modules can be assigned any of the logical channel addresses, the following sense bit indications are provided to allow the system program to identify which particular module is assigned a given address. Sense byte 4 will contain the identity of the disk drive corresponding to the address to which the sense command was issued.

The following shows the code used for module identification of disk drives. Bits 0 and 1 (shown as X) are not used.

Sense Byte 4	Disk Drive
XX000000	A
XX000001	B
XX000010	C
XX000011	D
XX000100	E
XX000101	F
XX000110	G
XX000111	H
XX001000	J
XX001111	Module not defined

2841 STORAGE CONTROL (Continued)

Sense Information Summary (Continued)

Byte 5

This byte is zero at all times except when overflow incomplete occurs (Byte 1, Bit 7). When overflow incomplete occurs, this byte has one of the following configurations:

- 00000110 - A read command was in progress when the overflow incomplete interrupt occurred.
- 00000101 - A non-formatting write command was in progress.
- 00100101 - A search equal key data command was in progress, and the compare is equal to this point.
- 01000101 - A search high key data command was in progress, and the compare is equal to this point.
- 01100101 - A search high or equal key data command was in progress, and the compare is equal to this point.
- 01010101 - Any search key data was in progress and the compare is low, or a search equal key data was in progress and the compare is unequal to this point (i. e. , it has already been determined that no status modifier would be set on the entire logical record.)
- 01110101 - A search high or high-equal key data command was in progress, and the compare is high to this point (i. e. , it has already been determined that a status modifier would be set on the logical record).

If a "SPECIFY SYSTEM PARAMETERS" message is issued during nucleus initialization, it may be necessary to alter or cancel some of the following optional features:

OPTION	OPERATOR ACTION	PURPOSE OF OPTION
<u>PASS</u>	REPLY id, 'U'	No alteration is necessary.
<u>BLDL</u>	REPLY id, ' <u>BLDL</u> =xx'	Directory of the link library in main storage. 'xx' is change code.
<u>RAM</u>	REPLY id, ' <u>RAM</u> =xx, xx'	xx=List of access method modules to be placed into main storage.
<u>RERP</u>	REPLY id, ' <u>RERP</u> =xx, xx'	xx=List of error recovery procedures routines to be placed into main storage.
<u>RQ</u>	REPLY id, ' <u>RQ</u> =n'	n=Number of input queue records to be made resident in main storage. PCP only.
<u>RSVC</u>	REPLY id, ' <u>RSVC</u> =xx, xx'	xx=List of non-resident routines to be placed into main storage.
<u>ALTSYS</u>	REPLY id, ' <u>ALTSYS</u> =ddd'	ddd=Alternate system residence device MFT & MVT only.
<u>MIN</u>	REPLY id, ' <u>MIN</u> =nn'	nn=Number of 1024 byte areas required to initiate a job. MFT & MVT only.
<u>SQS</u>	REPLY id, ' <u>SQS</u> =n'	n=Number of 2048 byte areas to be added to the system queue area. MFT & MVT only.
<u>HRAM</u>	REPLY id, ' <u>HRAM</u> =xx, xx'	xx=List of modules to be made resident in Hierarchy 1 storage. MVT only.
<u>HSVC</u>	REPLY id, ' <u>HSVC</u> =xx, xx'	xx=List of non-resident SVC routines to be made resident in Hierarchy 1 storage. MVT only.
<u>MOD</u>	REPLY id, ' <u>MOD</u> =nn'	nn=CPU model (40, 50, etc.). MVT only.
<u>MPS</u>	REPLY id, ' <u>MPS</u> =nn'	nn=Number of 2048 byte areas reserved for the Master Partition. MVT only.
<u>QBF</u>	REPLY id, ' <u>QBF</u> =nnn'	nnn=Number of 1024 byte areas reserved for buffers for the job queue. MVT only.
<u>CANCEL</u>	REPLY id, ' <u>BLDL</u> ='	Example would cancel the BLDL option generated into the system.
<u>LIST</u>	REPLY id, 'U, L' REPLY id, ' <u>RAM</u> =xx, L'	List BLDL, RAM, RSVC modules. Example will alter RAM option and list the RAM module.

The following is an example of a combination of option alterations not to exceed 80 characters/line:

```
REPLY id, 'RAM=xx, xx, xx, L CONT'  
REPLY id, 'BLDL=xx, L RSVC=xx, xx, xx, xx, L'
```

REDEFINING PARTITIONS

At the time the nucleus is initialized, alterations may be made to the size and number of partitions which were generated into the system.

- The number of partitions may be reduced.
- The size of each partition may be changed with the following limitations:
 - 1 - A partition cannot be less than 6144 bytes or 8192 bytes (MFT).
 - 2 - The lowest priority partition cannot be smaller than the scheduler (except for MFT).
 - 3 - Systems with storage protection will round partitions to the next higher 2048 bytes multiple.

REDEFINING PARTITIONS (continued)LIST PARTITION SIZES?

Message issued by MFT system

REPLY id, 'YES'

Redefine partitions

REPLY id, 'NO'

Proceed with no changes

Operator response

P0=number P1=number P2=number P3=numberEXCESS=NUMBER BYTES WILL BE GIVEN TO LOWEST PRIORITY PARTITIONINDICATE CHANGE, LIST, OR END

Message by system in response to operator message of 'YES' above

REPLY id, 'END'

No further changes needed

REPLY id, 'Pn=x', 'Pn1=x1'

Change size:

n=decimal partition number

x=decimal size desired

REPLY id, 'Pn=LAST END'

Reduce number of partitions:

n=highest partition number desired

REPLY id, 'Pn=LAST LIST'

To list partition sizes

ERROR RECOVERYINVALID PARAMETER/FORMAT - RESPECIFY

Error message caused by operator command

To correct, reissue command.

TOTAL SIZE OF PARTITIONS IS X BYTES TOO LARGE FOR STORAGE

To correct, redefine partition size.

READY

Message by system indicating partition alteration is complete.

OPERATING SYSTEM IPL PROCEDURE

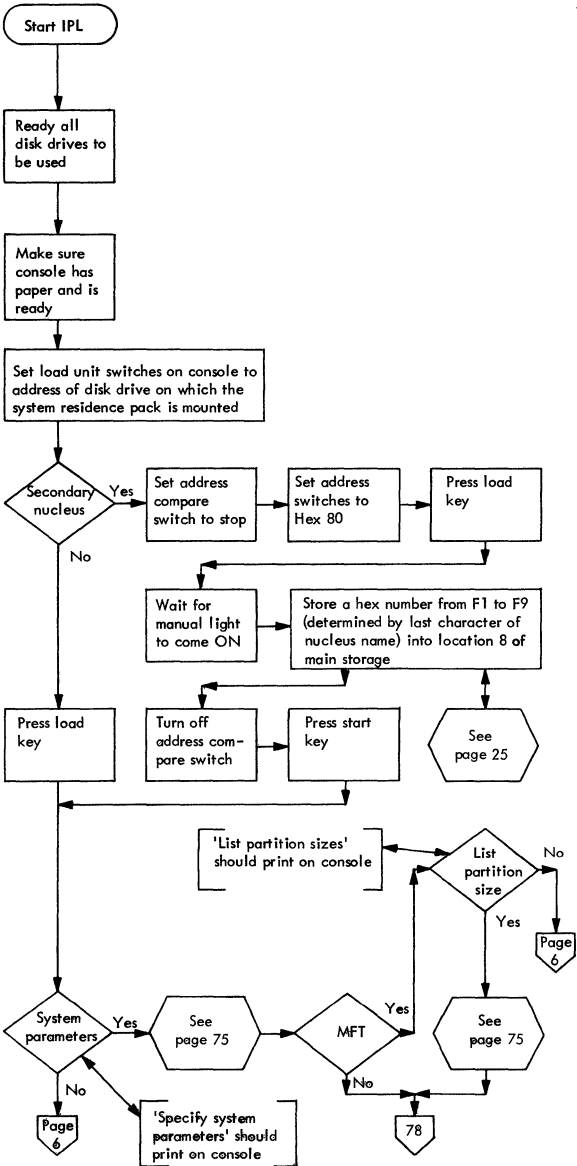

4

OPERATING SYSTEM IPL PROCEDURE

OS

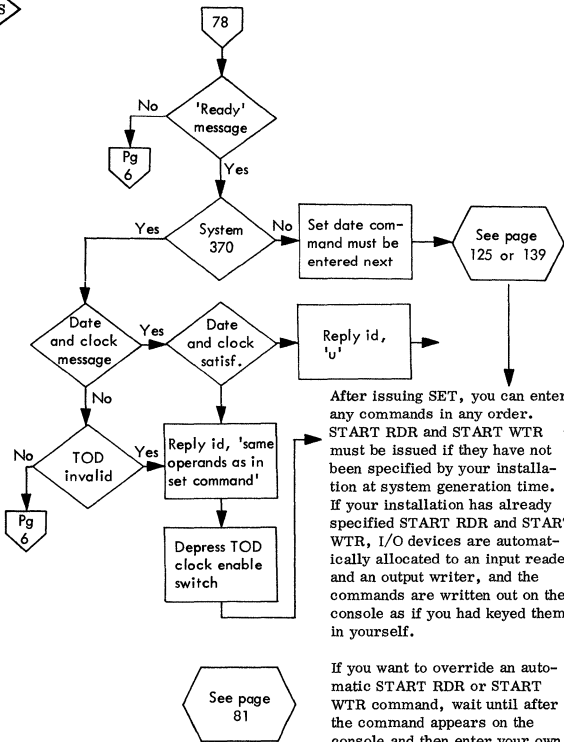

After issuing SET, you can enter any commands in any order. START RDR and START WTR must be issued if they have not been specified by your installation at system generation time. If your installation has already specified START RDR and START WTR, I/O devices are automatically allocated to an input reader and an output writer, and the commands are written out on the console as if you had keyed them in yourself.

If you want to override an automatic START RDR or START WTR command, wait until after the command appears on the console and then enter your own command manually.

If PCP, you must enter a START command with no parameters as the last command.

TO COMPUTE DAY OF YEAR FOR SET DATE ddd PARAMETER

PARAMETER: $ddd = (m-1) 30 + t + a$
 Where m = month number
 t = day of month
 a = adjustment for month (see table)

EXAMPLE:

June 5, 1969
 $ddd = (6-1) 30 + 5 + 1$
 $5 \times 30 + 5 + 1$
 $= 156$

NOTE: For Leap Year add 1 to ddd AFTER Feb 29.

ADJUSTMENT TABLE (SEE NOTE)

Month	m	a	month	m	a
Jan	1	0	July	7	1
Feb	2	1	Aug	8	2
Mar	3	1	Sept	9	3
Apr	4	0	Oct	10	3
May	5	0	Nov	11	4
Jun	6	1	Dec	12	4

PCPExamples:

1. To start a system with automatic START RDR and START WTR:

```
SET DATE=yy.ddd,Q=(unitname,F)
START
```
2. To start a system and to remove an I/O device from the system before processing:

```
SET DATE=yy.ddd,Q=(unitname,F)
START RDR,unitname
START WTR,unitname
VARY unitname,OFFLINE
START
```
3. To start a system with a timer, and to remove two I/O devices before processing:

```
SET DATE=yy.ddd,CLOCK=hh.mm.ss,
    Q=(unitname,F)
START RDR,unitname
START WTR,unitname
VARY unitname,OFFLINE
VARY unitname,OFFLINE
START
```

MFT

1. To start a system that has automatic START reader, START writer, and START INIT commands (the CLOCK operand in each example is optional) (x = partition number):

```
SET DATE = yy.dd,CLOCK = hh.mm.ss
DISPLAY JOB NAMES
```
2. To start a system that has automatic commands, but to suppress them:

```
SET DATE = yy.ddd,CLOCK = hh.mm.ss,AUTO = NONE
DISPLAY JOB NAMES
START WTR.Px
START RDR.Px
START INIT.P2,,,ACB
```
3. To start a system that does not have automatic commands, and to remove an I/O device from the system before processing:

```
SET DATE = yy.ddd,CLOCK = hh.mm.ss
VARY unitaddr,OFFLINE
START writer.Px
START reader.Px
START INIT.P0,,,A
START INIT.P2
```

MFT

Example:

IPL WITH PARTITION CHANGES, OVERRIDING OF THE AUTOMATIC
COMMANDS AND UCS PARAMETER SETTINGS

```

IEA101A    SPECIFY SYSTEM PARAMETERS

00 IEE801D CHANGE PARTITIONS ?

r 00, 'YES'

00 IEE802D ENTER DEFINITION

r 00, 'p1=(a,80k), p2=(a,80k,last), end'

IEE812I P 02 HAS      12288 EXCESS BYTES ADDED
IE
    E805I DEFINITION COMPLETED
IEE101A READY
S WTR.P0,00E *
S RDR.S,00C *
S INIT.ALL *

t date=69.091,q=190,auto=nnn,clock=10.04.00

IEF249I FOLLOWING P/R & RSV VOLUMES ARE MOUNTED
WORK01 ON 190      (P/R-PUB)
LANG01 ON 191      (P/R-PUB)
DLIB02 ON 290      (P/R-PUB)
SYSRES ON 291      (P/R-PUB)

v (192,193),offline
d jobnames
s init.p2
s psrdr.pl
s wtr.p0,00f,,ab

P01 IEF403I PSRDR      STARTED
P01 IEF281I DEVICE 192  NOW OFF-LINE PSRDR
P01 IEF281I DEVICE 193  NOW OFF-LINE PSRDR
P01 IEF236I ALLOC. FOR PSRDR      P1
P01 IEF237I IEFRDER  ON 00C
IEA000A INT REQ,00C,02,0200,4000
P02 IEF403I WTR      STARTED
P02 IEF236I ALLOC. FOR WTR      P0
P02 IEF237I IEFRDER  ON 00F
00 P00 IEC123D 00F SPECIFY UCS PARAMETER

r 00, 'U'
P00 IEF868I WTR 00F WTR WAITING

```

OPERATING SYSTEM IPL PROCEDURE (continued)

MVT

1. To start a system that has automatic START RDR, START WTR, and START INIT commands:

```
SET DATE=yy.ddd,CLOCK=hh.mm.ss,  
    Q=(unitname,F)
```

2. To start a system that has automatic commands, but to suppress them, and to start a reader, a writer, and an initiator:

```
SET DATE=yy.ddd,CLOCK=hh.mm.ss,  
    Q=(unitname,F),AUTO=NONE  
START WTR,unitname  
START RDR,unitname  
START INIT
```

3. To start a system that does not have automatic commands, and to start a reader and two initiators, and to remove an I/O device from the system before processing:

```
SET DATE=yy.ddd,CLOCK=hh.mm.ss,  
    Q=(unitname,F)  
START RDR,unitname  
START INIT  
START INIT  
VARY unitname,OFFLINE
```

DOS/TOS IPL PROCEDURE

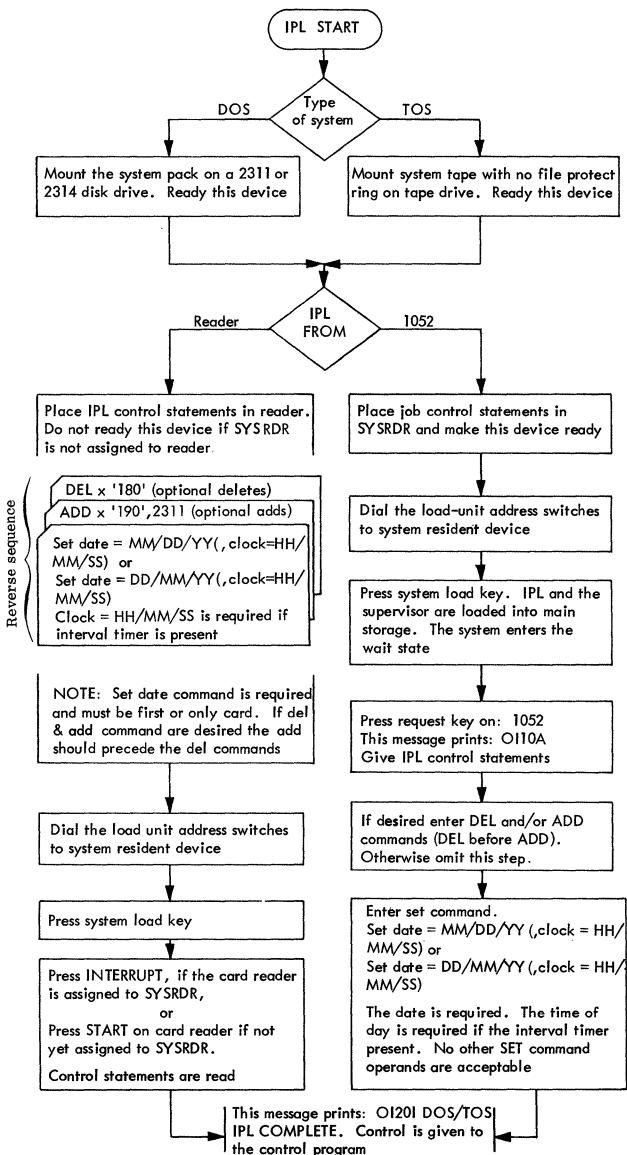

O/S (PCP) CHECKPOINT RESTART

HOW TO RESTART A JOB

Automatic Restart

When you receive the message requesting your authorization for a restart:

IEF225D SHOULD job RESTART

and the JCL statements describing the ended job are punched into cards, return all cards in the input stream to the hopper. After replying YES, you will get a message:

IEF226A LOAD JOB jjj INTO DEVICE utn

Ignore the message for card input, because you've already loaded the job.

If the failing job step used one or more card input data sets, you must return, to the appropriate hoppers, all data cards that may have been read during this job step.

Enter r id, 'YES'

Follow the mounting instructions issued by the system.

Deferred Restart

The job to be restarted is submitted by the programmer as a normal run. When the system completes the restart procedure on the job, you will get a message:

IHJ0081 job RESTARTED

and the job will continue. No action on your part is necessary.

O/S (MFT/MVT) CHECKPOINT RESTART

HOW TO RESTART A JOB

Automatic Restart

When the system is requesting your authorization for an automatic restart, you will receive the message:

IEF225D SHOULD job RESTART

Use the REPLY command, and answer the message with one of the following:

- | | |
|--------------|--|
| r id, 'YES' | This authorizes an immediate restart. |
| r id, 'NO' | The restart is canceled. |
| r id, 'HOLD' | The restart is suspended until you enter either the RELEASE jobname or CANCEL jobname command. |

Deferred Restart

The job to be restarted is submitted by the programmer as a normal run. When the system completes the restart procedure on the job, you will get the message:

IHJ0081 job RESTARTED

and the job will continue. No action on your part is necessary.

RESTARTING A JOB FROM A CHECKPOINT (DOS)

When a job is canceled before the normal end-of-job, it can be restarted immediately or at some later time. If checkpoints are not taken as part of the job, the job must be re-executed from the beginning as a new job.

If the programmer has included checkpoints in his job, the message,

```
0C00I CHKPT nnnn WAS TAKEN ON SYSxxx=cuu
```

is given each time a checkpoint is taken.

Checkpoint/restart capabilities are provided for background and foreground programs operating in a batched mode, within the following limitations:

- The checkpoint job must be restarted in the same partition in which the checkpoint was taken.
- Checkpoint records written by previous versions of the system cannot be restarted in the current system.
- It is possible to increase the size of the partition between the time the checkpoint is taken and the time the program is restarted, provided the starting address of the partition remains unchanged.
- The checkpoint can be recorded on a tape or 2311/2314 disk unit.

Most programs can be restarted after a checkpoint by using the following procedure. Some IBM-supplied programs (e.g., Disk Sort Merge) use other procedures for restarting from a checkpoint. For these cases, the appropriate program specifications manual should be consulted for the correct restarting procedure.

- Replace the // EXEC statement with a // RSTRT statement using the information in the last 0C00I message received. The programmer should have specified the checkpoint unit when the job was submitted. There is no need to linkage edit the program again. When labeled multi-volume tape reels are concerned, the volume sequence number must be changed to reflect the volumes for restarting if they are other than specified for volume number 1. Otherwise, a header check error will occur when trying to open subsequent volumes for the files. All other Job Control statements should be the same as when the job was originally run. If necessary, the channel and unit addresses for the // ASSGN statement may be changed.
- Rewind all tapes used by the program being restarted and mount them on devices assigned to the symbolic units required by the program.
- Execute the job.

Note: If the Job Control statements were read from a tape or disk, the operator might not be able to restart the job conveniently. In this case, the job should be returned to the programmer.

GENERAL HINTS ABOUT TAPE DRIVES

1. When you put the tape on the hub, make sure the reel is completely on.
2. Make sure the tape is taut and that the load point sticker is in the correct place before pressing the load (start) button.
3. If the tape drive doesn't load (become ready) check the capstans (2401 Mod 2-6), they may be stuck in the retracted position or in a partially extended position. Also if during on-line operation the tape drive hangs in a loaded position not ready, check to see if the capstans are fully retracted (2401 Mod 2-6).
4. Be sure to use the correct tape for your Model tape Drive. (Do not use 556 tested BPI for phase encoded tape drives).
5. If you try to write on a file protected tape (tape ring out), command reject results.
6. The CB lite indicates a power malfunction, call a CE.
7. If power is up, and the tape drive is unloaded, only the file protect lite should be on (unless tape drive is being selected). Sometimes the lenses get swapped around and unusual conditions are indicated (Ready lense lite all the time). Check to see that all lenses are in their correct location.
8. If you are experiencing I/O errors while trying to read an input tape, try reading it on the drive that created the tape, (if possible). If it reads OK, you may have a tape drive compatibility problem. Notify your CE of this condition.
9. If you see a new tape that "Runs Away" when it is selected the first time, rewind to load point and write a tape mark, now restart job.
10. Power Window:

If window stops halfway thru a raise or lower, this usually indicates a broken or malfunctioning cable inside the door. Call the CE.
11. If the drive drops ready or won't load, check the door interlock switch. If the door isn't closed properly, no action can take place.
12. Oxide deposits in the tape transport area will cause data checks. Clean tape drive according to local conditions.
13. Be extremely careful while handling tape reels. Keep tape reel covers on at all time when the reels are not being used.
14. Tapes do wear out. If you are experiencing I/O errors on an Output (write) tape, strip off about 10 feet of tape. Now put a new load point sticker about 12 feet in from the new beginning and write a TM. Some installations have a tape librarian that takes care of "tape stripping."

24XX TAPE DRIVES

GENERAL OFF-LINE MANUAL PROCEDURES

CAUTION: When using this procedure, rings, wristwatches, chains, bracelets, or metal cufflinks must not be worn. If the CPU is manually stopped and the tape control unit (TCU) is taken offline for manual operation it will be necessary to reIPL the system to ensure correct operation.
Reason: If the reset button on the TCU is pressed, device end interrupts and arming will be lost.

HINT: Refer to Section 3 for command codes.

Writing a Tape Mark

Example: To write a tape mark on a 9 track tape drive (Models 1-3) with an address of '182'.

- NOTE:**
- a) If a 7 track tape drive is to be used, a mode set command must be performed first. See Step 5 below.
 - b) Do not take control unit (2803) off-line unless central processor is stopped.

1. Take control unit off-line.
Transfer the off-line toggle switch (located lower left of CE panel) to the off-line position.

2. Insert command (WTM)

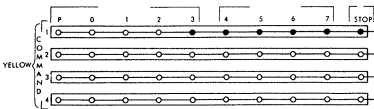

Insert pegs according to black dots above.

3. Address tape drive.

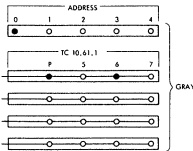

Insert pegs according to black dots above.

NOTE: Address 1 ~~8~~ 2
not used use this as address.

4. Depress machine reset and start push buttons.
The write tape mark operation is complete.

5. If a 7 track tape drive is used:
 - a) First perform a set mode command.

For 556 BPI, even parity

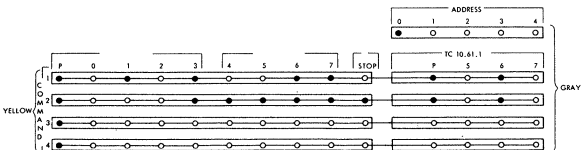

For 800 BPI, odd parity

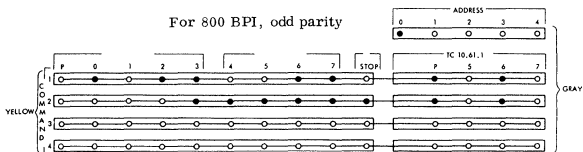

For all other modes of operation see general section of this book.

NOTE: If the above procedure fails:

- Check the interface toggle switch (it should be on 'auto').
- Check the multi/single toggle switch (it should be on multi).

- If using a 2415 CE panel:
 - Set remote/local switch to local.
 - Set tape drive rotary switch to desired tape drive (0-5).
 - Set command switch to byte (sometimes called control).
 - The command can now be put in the bus out toggle switches.

BUS OUT

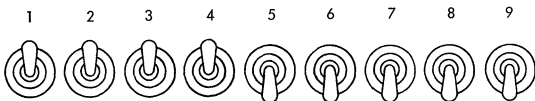

9 TRACK WTM

- All switches in the middle of the panel should be down.
- Press start.

NOTE: If other than 9 track 800 BPI, a mode set command must be performed first without an intervening machine reset.

TAPE CLEANING (EVERY 8 HOURS OF USAGE)

CAUTION: When cleaning the transport area, care must be taken to prevent any IBM tape cleaner (IBM P/N 517960) from getting on the bearings and bushings because it will leech oil from them. Do not use any metal instrument to clean the vacuum columns.

To clean the tape transport area:

- Unload tape from the tape unit.
- Remove dust from reel and transport area with a lint-free cloth.
- Clean the rewind idlers (2415, column guide rollers) with a lint-free cloth moistened with tape transport cleaner. Use a wooden toothpick to remove stubborn oxide clumps. Clean the capstans (2415, one only) with a lint-free cloth moistened lightly with tape transport cleaner.

CAUTION: Excessive amounts of tape transport cleaner may deteriorate the capstan material.

Clean the prolay idlers with a lint-free cloth moistened with tape transport cleaner (2401-2404 only).

Clean the read/write head with a cotton swab moistened lightly with tape transport cleaner. The vacuum columns should be cleaned weekly by using a lint-free cloth or pad moistened with tape transport cleaner. Use a wooden toothpick to remove stubborn oxide clumps.

3420 TAPE DRIVES

OPERATING PROCEDURES AFTER FAILURE (3420)

Tape Fails to Thread (With Cartridge)

1. Demount reel and cartridge.
2. Ensure tape end is undamaged and hangs free in cartridge (if necessary, trim end with cutter, part 2512063).
3. Check that unlatching cartridge toggle opens tape port.
4. Remount reel and cartridge and retry load procedure.
5. If failure recurs, remove reel from cartridge and try load procedure without cartridge.

Tape Fails to Thread (Without Cartridge)

1. Ensure tape end is undamaged and positioned in threading chute (if necessary, trim end with cutter, part 2512063).
2. Open doors and clear any obstructions from tape path.
3. Close doors and retry load procedure. If unit still fails, notify CE.

End of Tape Comes Off Machine Reel Hub as Tape Loads in Columns

To recover information from tape with short leader, attach additional temporary leader with clear cellophane tape.

Note: After information is recovered (reproduced on another tape reel), recondition source reel by cutting off old leader and BOT marker. Trim end with cutter, and apply new BOT marker about 15 feet (4.6 m) from leading end. Have marker parallel to and about 1/32 inch (0.8 mm) from front edge of tape. Marker must not be wrinkled nor extended beyond tape edge.

Tape Unit Fails to Sense EOT Marker (Tape End Comes Off File Reel)

Verify presence of EOT marker approximately 25 feet (7.6 m) from end of tape. If marker is present, malfunction could be program error or machine failure - notify CE.

1. Rewind Procedure - With Cartridge:
 - a) Open front door and manually wind remaining tape on machine reel. Close front door and press RESET and UNLOAD. When cartridge closes, remove cartridge and reel and mount an empty reel on machine.
 - b) Open doors, manually thread tape from machine reel through tape path, and wind approximately ten turns of tape on file reel. Close doors and press LOAD REWIND.
 - c) Unload tape unit and return reel to cartridge when rewinding is complete.
2. Rewind Procedure - Without Cartridge:

Do (b) above. Unload tape unit when rewinding is complete.

Tape Threads Successfully But Fails to Load in Columns

Check for missing BOT marker, or incorrect leader length (distance from tape end to BOT marker). Tapes with less than 10 foot (3 m) or greater than 30 foot (9 m) leaders may not load reliably. If neither condition is present, notify CE.

Window Fails to Open After Unload Operation

1. Open access door and manually wind remaining tape onto file reel.
2. Close front door and press RESET and UNLOAD.

Writing a Tape Mark (3803/3420)

1. Set the ENABLE/DISABLE switch(es) on the control unit operator's panel to 'Disable'. The CPU should be stopped momentarily (press STOP then START at the CPU) to ensure that the control unit becomes disabled.
2. Open the 3803 back cover. (Remove rings, wristwatches, chains, bracelets, or metal cufflinks.)
3. Set CE Panel switches as follows:
 - a) PANEL ENABLE to 'enable'.
 - b) ROS MODE (rotary switch) to 'norm'.
 - c) DATA ENTRY SELECT to 'cmnd1'.
 - d) DATA ENTRY (three switches) to '1FX (PE tape mark), where X is the address (hex) for the tape unit that is to write the tape mark.

Note: To write an NRZI tape mark, two commands must be loaded and executed. The first is the appropriate mode set, and the second is the write tape mark (WTM). At this point, enter mode set command and TU number in the three DATA ENTRY switches (hex).

- e) MPLE/SINGLE to 'single'.
 - f) DISPLAY SELECT to 'CE reg'.
4. Activate the following switches in the sequence shown:
 - a) SET ROS MODE/SET CE/CMPR to 'set ROS mode' then to 'set CE cmpr'.

Note: To write an NRZI tape mark, set DATA ENTRY switches to 1FX (see step 3d), and DATA ENTRY SELECT to 'cmnd 2'. Press 'Set CE/cmpr' again.

- b) RESET/START or STOP to 'reset'.
 - c) STOP/START to 'start'. This writes a PE tape mark. (Press 'start' again to write an NRZI tape mark.)
 - d) Repeat steps 4b and 4c to write additional tape marks.
5. Set the PANEL ENABLE switch down (OFF), close the rear cover, and set the channel ENABLE switch to the desired position.

CAUTION: Failure to turn off the PANEL ENABLE switch could disrupt system operation at some later time.

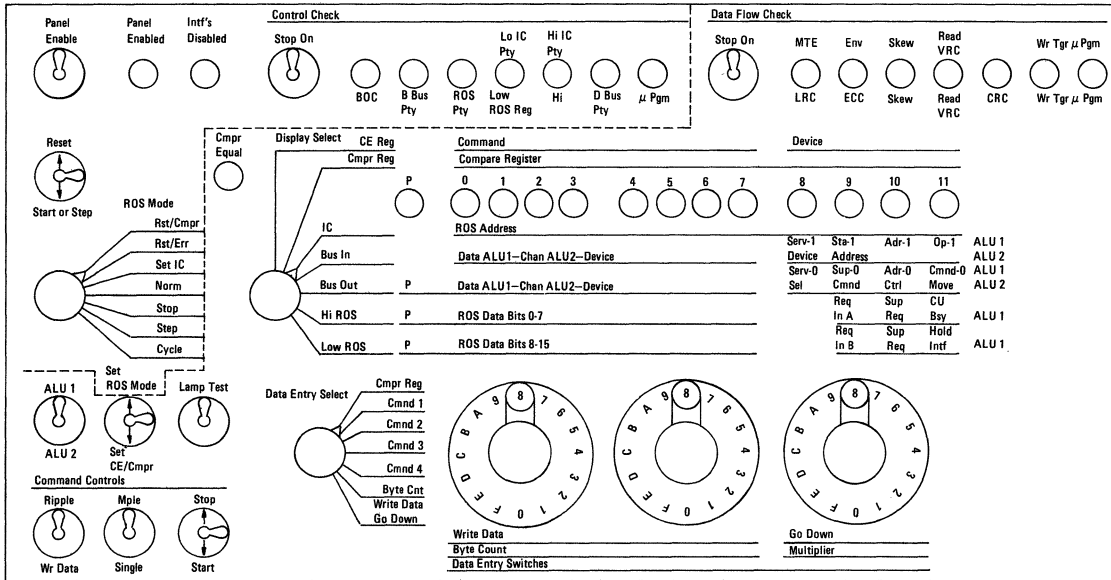

Tape Transport Cleaning (3420)

1. Unload tape and remove from tape unit. Do not operate door interlock switch.
2. Install capstan cover.
3. Clean tape guides, threading channels, air bearings, vacuum columns, and vacuum column door glass with lint-free cloth moistened with tape cleaner. Use small brush to remove stubborn oxide buildup. Water may be used to remove oxide residues in vacuum columns. Do not use water near capstan.
4. With small brush clean intakes at bottom of vacuum columns and reel tachometer surfaces.
5. Remove capstan cover and clean read/write head surface with small brush.
6. Wipe read/write head, erase head, and tape cleaner with lint-free cloth moistened with tape cleaner. Be careful not to disconnect erase head wires.
7. Clean lower portion of rewind plunger and tape break mirror (above BOT/EOT block) with cotton swab moistened with tape cleaner.

23XX DIRECT ACCESS

GENERAL, 23XX

1. A select lock indicates an unsafe condition within the drive. When the red light comes on, it is safer NOT TO touch the file until a CE can look at it. He can determine what caused the select lock if the conditions that caused it are still indicated. If you try to reset the select lock by turning the drive off and on again, you may destroy a complete cylinder of information on the pack. If at all possible, work around that file until a CE can correct the malfunction.
2. Handle a disk pack only with its cover on. If the disk pack is accidentally dropped, or receives a sharp impact of any kind, have it inspected by an IBM Customer Engineer before you use it. Don't be reluctant to report a damaged pack. (Extensive damage could result.)
3. Defective Tracks - All packs now shipped from the factory will contain a label on the sector disk and a separate label in the shipping container listing (in decimal notation) the defective tracks. These tracks should be considered defective and not tested when using the stand-alone utility programs (OS/360 Independent Utilities 360S-UT-507 or BPS/360 Initialize Disk 360 P-UT-206). Alternate tracks should be assigned for these defective tracks with one of the following methods, depending upon the programming system being utilized.
 1. For OS, use the GET-ALT function of the DASDI stand-alone utility (OS/360 Independent Utility 360S-UT-507) to flag the tracks and assign alternate tracks from the list.
 2. For DOS, use the stand-alone utility 360P-UT-206, UT-207 to flag tracks and assign alternates from the list.

IBM Programming Systems consider cylinders 200-202 as the alternate track cylinders.

Packs are tested at the plant under very rigid and extreme conditions. The tracks that are found to be defective are so under these conditions and IBM feels that it is wiser to use one of the many alternate tracks that are available.

4. Disk Pack Loading and Unloading: The following procedures should be followed for rapid, effective disk pack changing:

Loading:

1. Open the 2311 cover. (2314 drawer)
2. Remove the bottom disk pack cover by turning the bottom locking knob.
3. Place the disk pack (still contained in the top cover) on the spindle.
4. Turn the top cover in direction of ON arrow until firm resistance is met.
5. Lift the top cover from the disk pack.
6. Close the 2311 cover. (2314 drawer)
7. Press the start key.
8. Reassemble the top and bottom covers of the disk pack.
9. Store the covers in a clean cabinet or on a clean shelf.

CAUTION

Do not leave disk pack cover inside disk drive.

Unloading:

1. Press the stop key.
2. Wait until the rotating pack comes to a complete stop.
3. Open the 2311 cover (2314 Drawers).
4. Separate the top and bottom disk pack covers.
5. Place the disk pack top cover over the disk pack.
6. Turn the top cover in direction of OFF arrow at least two full turns.
7. Lift the top cover, now containing the disk pack, from the spindle.
8. Fasten the bottom cover firmly to the disk pack.
9. Close the 2311 cover (2314 drawer).
10. Store the disk pack in a clean cabinet or on a clean shelf.

5. Disk Pack Handling and Storage

Careful and correct handling and storing of disk pack is vital for a successful installation.

For complete details on disk pack handling and storage, refer to "IBM Disk Pack Handling and Operating Procedures" (Form A26-5756).

To assure maximum disk pack life and reliability:

1. Store the disk packs flat, not on edge.
2. Each pack should rest on a shelf, not on another disk pack.
3. Store in a clean, enclosed metal cabinet or a similar fire-resistant container, never in direct sunlight.
4. Store disk packs in a machine-room atmosphere (60° to 90° F, 10% to 80% humidity).
5. If a disk pack must be stored in a different environment, allow two hours for adjustment to machine room atmosphere before use.
6. Always be sure that both the top and bottom plastic covers are on a disk pack whenever it is out of a module location (on a drive spindle).

6. Disk Pack Labeling

For identification purposes, small adhesive-backed labels can be placed on the disk pack center hub. Labels in this location can be read through the transparent disk cover.

The following procedures should be used when labeling disk packs:

1. Use adhesive-backed labels that can be applied and removed easily.
2. Use a writing implement, such as a pen or felt-tip marker, that does not produce a loose residue. Do not use a lead pencil.
3. Write on the label before it is applied to the disk pack.

4. Place the label only on the center hub, not on the disk pack cover or top disk surface.
5. Use a new label if changes to the label information are necessary. Never erase a label that is on a disk pack. Microscopic eraser particles can damage disk surfaces and read/write heads.
6. Removal or placement of labels can be done only when a disk pack is in place on a drive. Do not attempt to remove the top cover when the disk pack is out of the drive.

7. Head/Disk Interference

Head disk interference (HDI) is a result of R/W head contact with a disk surface. Usually a foreign particle in the air stream or a protrusion from the disk surface causes the R/W head to break through the air "bearing" and abrade the disk surface. If the problem is not totally corrected, it has a propagation effect from pack to pack and, in turn, drive to drive.

Symptoms

Head crashes can be recognized by one or more of the following symptoms:

1. Sudden hard read errors. Because HDI damage will propagate, do not move any pack with this kind of error to more than one other drive. If the error persists, stop both drives and investigate further for HDI.

CAUTION: The operator may not have recognized the head crash symptoms and propagated damage to other packs/drives by moving the disk pack. The operators should be made aware of these symptoms and of the procedures that are set up to hold damage propagation to a minimum. Refer to the IBM Disk Pack and Cartridge Handling Procedures manual. (Form A26-5756)

2. Uncommon noise from the disk is characterized by audible tinkling sounds. If allowed to continue, the noise will progress to a screech.
8. When it is necessary to call a CE because of intermittent file errors, save for him the error message printout on the console and if available the DASDI print of that pack (when the pack was initialized last).

2314 OPERATOR CONTROLS AND INDICATORS

MODULE IDENTIFIER PLUGS

Each of the nine file modules has a module identifier plug receptacle. If a module identifier plug is placed in the module's receptacle, the access mechanism of that module is positioned at cylinder 000 and a not-ready-to-ready-sequence device end is then presented to the channel from the control unit. Each removable module identifier plug has a unique address which is one of the values in the range 0 through 7. The module identifier plug for the spare drive is labeled "S".

CHANGING A MODULE ADDRESS

The address of a file module is normally changed only when a file module requires maintenance. To change the address of any module:

1. Make sure that the program(s) controlling the 2314 is in a wait state or that the existing condition allows removal of module identifier.
2. Remove the module identifier plug from the affected modules and perform any necessary pack changes.
3. Place the module identifier plugs in the appropriate receptacles.
4. Program control is now in effect.

Note: Module identifier plugs should either be inserted all the way or removed completely.

ENABLE/DISABLE SWITCH

The 2314 contains an enable/disable switch on the single drive module of the 2314. The switch enables or disables communications between the 2314 and the CPU channel. If the two-channel switch special feature is installed, each channel has its own enable/disable switch.

The 2844 provides an additional enable/disable switch on the single drive module of the 2314. If the two-channel switch special feature is installed in the 2844, each channel has its own enable/disable switch.

A single usage meter (located in the single drive module of the 2314) records processing time when communications have been enabled by an enable/disable switch being in the enable position. To enable communications between a channel and the 2314/2844 the following conditions must exist:

1. The enable/disable switch associated with the channel being enabled must be in the enable position.
2. The CPU must be in a stopped or wait state.

To disable communications between a channel and the 2314/2844 the following conditions must exist:

1. The enable/disable switch associated with the channel being enabled must be in the disable position.
2. The channel selection switch in the 2314/2844 must not be selected to the channel being disabled.
3. The CPU must be in a stopped or wait state.

If the CPU enters the stopped or wait state when the 2314 contains outstanding status, the status may be made unavailable if the enable/disable switch associated with the channel has previously been set to disable.

UNTAGGED-TAGGED TOGGLE SWITCH

When the 2844 is attached to the 2314, an untagged-tagged switch is placed on the front of the ninth disk module in the 2314. (Also, a separate untagged-tagged switch is provided on the ninth module for each two-channel switch feature used in the 2314 complex.) The manner of presentation of a device-end resulting from making the 2314/2844 ready is determined by the setting of this switch. Such a not-ready-to-ready-sequence device end occurs after a disk pack change is completed and the affected module is returned to an on-line condition.

When the switch is in the tagged position, device end for the not-ready-to-ready-sequence is presented to all channels connected to the 2314/2844. After the device end is accepted, the module can be addressed for command execution by the channel that accepted the device end. Before any other channel can use the module, it must also receive the not-ready-to-ready-sequence device end.

If the toggle switch is in the untagged position, the 2314/2844 attempts to present the not-ready-to-ready-sequence device end to all channels connected to the 2314/2844 complex. This device end is cleared as soon as it is accepted by any channel, and no further attempt is made to present the device end to any other channel.

CAUTION: If the switch is set to the untagged position, the programming environment must be such that the device-end interruption can logically be cleared by any channel to which the 2314/2844 complex is attached. If separate supervisor programs are used and the device end interruption must be indicated separately to each supervisor, then the switch must be set to the tagged position.

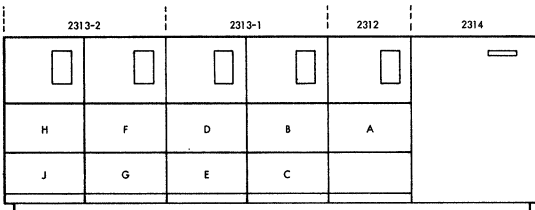

MODULE IDENTIFICATION

2301 AND 2303 DRUM

Under no circumstances should anyone except an IBM CE open the upper enclosure door.

An operator should never power up the 2301 or 2303. Under normal operating environment, the power switch on the 2301 CE panel is always left in the remote position.

To power down the system without losing power to the drum, turn the local/remote switch to local. If for any reason power has been dropped on the 2301 or 2303 (especially building power failure) an IBM CE should be called to power up the 2301 or 2303. The building power panel circuit breaker should never be used to turn power off of the drum. If for some reason building power has to be shut off, cover the top of all of the 2301's or 2303's with a clean, dry cloth or plastic and notify your CE.

The temperature of the drum should be checked once a shift, and if it exceeds 100 degrees, a CE should be called. The dial is located within the top enclosure at the top of the drum.

2820 DRUM CONTROL

Operating Considerations

Indicators

Four lights are on the 2820 (Figure 3).

1. AC on
2. DC on
3. POWER ON FILE
4. CB/TH (Circuit Breaker/Thermal)

During normal operation, AC on, DC on, and POWER ON FILE should be lighted but CB/TH should not be lighted. If this is not the case, notify the Customer Engineer.

The Customer Engineer should be notified if:

1. Five minutes after a power-on sequence is started, AC on and DC on are on but POWER ON FILE is off.
2. Thirty seconds after a power-off sequence is started, DC on and POWER ON FILE are on but AC on is off.

2321 DATA CELL DRIVE

1. **BEFORE ATTEMPTING TO REMOVE OR INSTALL A CELL**, review the Data Cell Handling Guide Form #A26-3633-1.
2. **LABELING**

The data cell container is transparent so that the label on the front surface of the cell can be easily read. The following procedures are recommended for data cell labeling:

1. Use an adhesive-backed label that can be applied and removed easily. Labels designed for this purpose are available under IBM P/N 2174086.
 2. Write on the label before it is applied. Use a writing implement that does not produce loose residue. Never use a lead pencil or wax crayon.
 3. Apply the label to the front surface of the cell, not to the cover or any other part of the cell.
 4. Use a new label if changes are necessary. Never use an eraser. Microscopic eraser particles can damage strips and the read/write head.
3. **CLEANLINESS**

- Keep the two-piece protective cover closed at all times, even when it is empty.
- Keep the machine door closed except when mounting or removing cells.
- Do not smoke while mounting or removing cells or in the storage area.

The prime concern is to reduce airborne contaminants to a minimum. Data handling errors may occur if these procedures are not followed. When the 2321 is turned on, the internal filtered air supply maintains the air pressure within the cell array at an air pressure slightly higher than the surrounding environment. This pressure tends to keep airborne contaminants from entering the cell array during operation. Hence, data handling errors may occur if the preceding procedures are not followed.

The machine room should be vacuumed or wet mopped daily. Never raise dust by use of such cleaning implements as a broom or a feather duster. If floor wax or other surface dressing is used, it must be of the non-flaking and non-dusting type and should be applied lightly. Never use steel wool or metal abrasives to clean or burnish floor tile.

Treat the top plastic cover with care. It is a mounting and removal tool in addition to serving as a protective cover.

4. WHAT NOT TO DO

- Do not expose the covered data cell to an intense magnetic field. Exposure to a strong magnetic field may cause loss of data.
- Do not attempt to accelerate the condition of the cell by use of a heater, cooler, or any such artificial means. Permanent deformation of the data strip may result if the temperature limits are exceeded.
- Do not store in direct sunlight. High temperatures within the data cell may cause permanent deformation of the strips.
- Do not stack data cells.
- Do not smoke while mounting or removing cells or in the storage area.
- Do not attempt to use a cell which has been dropped or which shows signs of damage.
- Do not attempt to remove the top cover from a cell unless the cell is in position on the spindle.
- Do not operate any switches on the operator panel if the Drum or bin is turning.
- Do not operate any switches on the CE Panel.

5. LIGHTS

Even if the Drive Ready Light is on, the 2321 will not perform write operations if the CE key is inadvertently left turned on in the CPU.

Thermal: If lighted, indicates that a high-temperature condition exists within the 2321.

Drive Select: If lighted, indicates that the storage control unit is communicating with the 2321.

Manual Controls

Enable/Disable: This switch controls the usage meter, which is located inside the 2321. The meter must be enabled before the 2321 can become operative. The CPU must be stopped in order to enable the usage meter.

Reset: This button allows the 2321 indicators to be reset in the event of an improper status condition. This reset will not establish a drive operative or drive ready status.

Restart: This button allows the restart of the 2321 after certain conditions occur, such as a momentary interruption of power.

PRINTERS, GENERAL

1. Make sure you double check the forms switch when you replace or add paper to the 1052 console.
2. Sync checks usually indicate that the print train or chain is dirty. Have the CE clean it.
3. CAUTION: Do not try to vacuum clean a train or chain. You may damage it. It is OK for you to clean the other parts of the printer.
4. Paper jams are usually caused by improper insertion of forms. Double check tension controls.
5. To prevent poor print quality, be sure your density control is set properly (also forms thickness).
6. Reload UCS buffer after:
 - a. Power down.
 - b. Sync check.
 - c. Print checks.
7. If the printer starts printing incorrectly after you replace a UCS train, you may have put the train on incorrectly. The instructions are located to the right of the train on the machine frame.
8. Irregular forms skipping and printing could be caused by:
 - a. Bad carriage tape (worn or mispunched).
 - b. Wrong forms type.
 - c. Wrong line drive (6/8).
9. Loss of the first few position of print could be caused by:
 - a. Skewed print ribbon.
 - b. Wrong paper form.
 - c. Bad positioning of forms.
 - d. Defective ribbon.
10. Sync checks on a 1443 could be caused by the typebar selector switch being set incorrectly for your typebar (13/48/53/63).
11. If the 1403 won't ready, check the indicator panel below the 6/8 line knob for an interlock that may be open.

MANUAL CONTROLS FOR THE IBM 1443

Clutch Knob

The manual-clutch knob controls the carriage-tape drive and the form-feeding mechanism.

Typebar Motor Switch

This switch, mounted under the top cover and near the typebar drive has three positions: ON, OFF, and TYPEBAR REMOVAL. The OFF position turns off the ribbon and typebar motors. For safety, use this position if the ribbon is to be replaced without removing the typebar. The typebar removal position turns off the ribbon and typebar motors. Use this position when removing or installing a typebar.

NOTE: Setting this switch to OFF or TYPEBAR REMOVAL turns on the form-check indicator. Correct this condition by turning the typebar motor switch to ON, and pressing the start key.

Typebar Selector Switch

This switch is used to select the character bar being used.

Byte-Burst Mode Switch

This switch included only on the model N1 printers, has four positions that determine the byte transmission rate when the printer is attached to the multiplexer channel.

The switch is ineffective if the model N1 is connected to the selector channel.

Start Key

When the 1443 N1 printer is set up for a printing operation, pressing the start key places the printer in ready status if the following conditions are met:

- AC power on.
- DC power on.
- Form-guide plates closed.
- Typebar in position.
- Typebar removal switch in ON position.
- Carriage brush assembly closed on carriage control tape.
- 6-8 line-space drive cover closed.
- End-of-form switch closed.
- No error conditions indicated on the console.

Pressing the start key with the end-of-form light on causes the printer to operate under the control of the system until a channel-1 punch is sensed in the carriage tape. This operation repeats each time the start key is pressed. Therefore, if no form is in the carriage, data is printed on the platen.

Ready Light

This light indicates that the printer has been conditioned by the operator to accept initial instructions and subsequent commands from the system. It is turned off when any one of the following conditions are sensed:

- When the stop key is operated.
- When the carriage stop key is operated.
- When an end-of-form is sensed.
- When an error is indicated and the printer is not busy.

A not-ready condition is sensed on the next command to the printer.

Sync Check Light

The sync check light turns on when the typebar is out of synchronism with the printer.

Form Check Light

The form check light is turned on for the following conditions:

1. Forms not feeding properly through the forms tractors.
2. Forms guide plates not in operating position on the paper.
3. The typebar switch is in the OFF or REMOVE position.
4. The carriage brushes are not down in operating position.
5. The 6-8 line-space control cover is not closed.

End-of-Form Light

This light comes on when about four inches of paper on the last form is left to be printed. However, the printer continues to operate until the carriage tape advances to a channel-1 punch, which removes the printer from ready status. If the start key is pressed, the machine restarts and continues to operate until channel 1 is sensed in the carriage tape. If the carriage tape is not punched in channel 1, the printer continues to operate. When the end-of-form and channel 1 are sensed, the machine ready status is turned off.

The end-of-form light is extinguished when the form is replenished.

Carriage Stop Key

Pressing this key stops the carriage operation and places the printer in a not-ready state, immediately.

Carriage Space Key

When the printer is in a not-ready state, pressing the carriage space key advances the form one space. The operation of the space key also causes the use meter to stop.

Carriage Restore Key

When the printer is in a not-ready state, pressing the carriage restore key causes the carriage to move to channel 1 of the carriage-control tape. If the manual-clutch knob is set to OUT, the form does not move. If the clutch is engaged, the form moves in synchronism with the control tape.

Intervention Required

This indicates that the 1443N1 is in a not-ready state because: the printer has run out of forms or forms have jammed; the stop key or carriage stop key has been pressed; the cover interlock switch is open; the typebar remove switch is set to the OFF or REMOVE position.

Suggested Restart Procedures for 1403 on System/360 Model 25 and Above

An I/O error causes an interruption condition. When unit check is detected by the program, sense information sent from the device control unit provides more-detailed information concerning the cause of the unit check. As a result of program analysis of the sense information, an error message should be made available to the operator to indicate the condition.

The following information describes the minimum actions that should be performed when the program detects unit check.

The actions are related to particular sense indications that can occur. These bits are analyzed by the program. The choice of action(s) to be taken by the operator must be established at the installation.

Intervention Required (Sense Bit 1)

The printer enters a not-ready condition (Ready light off) because one of the following has occurred:

1. The 1403 Stop key is pressed. (Possible operator error).
2. A mechanical interlock, such as the print unit, is open. (Possible operator error).
3. A forms check. When the Forms-Check light is on, paper feed trouble has occurred or the Carriage Stop Key has been pressed. (Also, the Ready light is off). Any jam condition must be corrected and the Check-Reset key must be pressed before the Start Key is effective. The program should provide an operator message and exit from this error recovery procedure. The operator should then perform one of the following:
 - a. Correct the not-ready condition, accept the record, and allow the application program to proceed without further retries of the command, or
 - b. Correct the not-ready condition and restart the program from a logical restart point. The logical restart point should be determined at the installation and specified to the operator.
4. End of forms. If an end-of-forms has occurred, the End-of-Forms light is on and the Ready light is off. To reset the printer, press the printer Start Key. The remaining lines of the form are then printed under program control. (Note that the Start Key is pressed only once).

When a hole is then sensed in channel 1 of the carriage tape (either space to or skip to or by channel 1), the operation is terminated with both the End-of-Forms and Forms-Check lights on and the Ready light off. Printing does not occur for the line at which the channel-1 hole is sensed. Therefore, a carriage tape with a hole punched in channel 1 should be on the carriage. If there is no hole in channel 1, printing continues even if no forms are in the printer (except for Selective Tape Listing operations).

If no skip-to-channel-1 command is issued, lines are printed (after the last form) until the channel-1 punch is sensed. (For Selective Tape Listing operation, new tapes should be mounted when the end-of-forms indication occurs.)

The program should provide an operator message and exit from this error recovery procedure when the end-of-forms indication is detected. The operator should then perform a forms runout (as just described) and satisfy the requirements of the application program.

5. Sync check. This condition can occur whenever the print chain (or train) is out of synchronism with the print circuitry in the 2821. Depending upon when the sync check occurs, one of the following conditions exists:
 - a. The sync check occurred when no printing was in progress (no line was printed).
 - b. The sync check occurred during a print operation and one line was printed.
 - c. The sync check occurred during printing and two lines were printed.

The program should provide an operator message and exit from this error recovery procedure. The operator should then:

- a. Correct the not-ready condition (press the Check-Reset key and then the Start key) and allow the application program to proceed without further retries of the command, or
- b. Correct the not-ready condition (press the Check Reset key and then the Start key) and restart the program from a logical point.

If the error persists, a call should be made to the Customer Engineer.

Data Check

Data check indicates that a code in a data record sent to the printer does not match a code in the UCS (Universal Character Set) feature storage. Printing does not occur in the print position to which the unmatching code applies. The entire line (except for the data check position) or only a portion of the line may be printed. Therefore, the last printed line may contain erroneous data and/or an incomplete record. Data check generally indicates that the UCS storage was improperly loaded or that a data record code (other than blank or null) does not compare to any code in the UCS storage.

The program should provide an operator message and exit from this error recovery procedure. The operator should then:

1. Accept the record and indicate that the application program is to proceed without further retry of the command, or
2. Cause the application program to restart from a logical point.

If the error persists, a call should be made to the Customer Engineer.

Parity Check

This bit indicates that a parity error has been detected in the UCS feature storage. The parity check can be reset only if the UCS storage is reloaded.

If the parity check occurs while the UCS storage is being loaded, retry the operation once. If the error persists, a call should be made to the Customer Engineer.

If the parity check occurs during printing, the last print line may contain erroneous data. Provide an operator message and exit from this error recovery procedure. At this time, the operator should:

1. Accept the record, cause the program to reload the UCS storage and proceed without further retry of the command, or
2. Cause the program to reload the UCS storage and restart the program at a logical point.

If the error persists, a call should be made to the Customer Engineer.

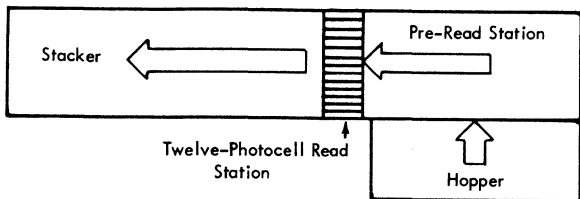

Ready indicates that the 2501 can accept a command from the program.

The ready light comes on when the following conditions exist:

1. Power is on.
2. A card is registered at the pre-read station.
3. Cards are in the hopper, or the end-of-file key has been pressed.
4. The stacker is not full.
5. No feed check condition exists.
6. No cover interlocks are opened.
7. The stop key has not been pressed since the last depression of the start key.

NOTE: Device End status is generated when the 2501 is made Ready. If the 2501 is made Not Ready, and then made Ready again before the channel accepts the first Device End, the ready light does not come on until this status is accepted.

Read Check (Equipment Check sense indicator) comes on when a card is not being read properly. This condition can result from off-punched cards or incorrect registration of cards in the transport. The Read Check is reset by the next read command from the program when the 2501 is not busy.

Validity Check (Data Check sense indicator) informs the operator that the card just read in data mode 1 contains more than one punch in rows 1-7 of a column. The validity check is reset by the next read command from the program when the 2501 is not busy.

Feed Check (Intervention-Required sense indicator) indicates a card jam or improperly positioned card in the hopper, transport, or stacker; or a failure of one of the read-station photocells or lamps. Usually, a feed check can be reset by an NPRO operation; otherwise, the operator must manually remove jammed cards from the transport or stacker area.

RESTART PROCEDURES for 2501

INDICATIONS	RESTART PROCEDURES
<p>Ready Light off Sense Bit 1 - Intervention Required</p>	<ol style="list-style-type: none"> 1. Check for full stacker, empty hopper, open cover, or actuated stop key. 2. Correct any error condition. 3. Remove cards from hopper. 4. Press NPRO key. 5. Place last card in stacker at front of input cards, and replace this deck in hopper. 6. Press start key.
<p>Ready Light off Feed-Check Light on Sense Bit 1 - Intervention Required</p>	<ol style="list-style-type: none"> 1. If there is a card jam, correct any jammed cards. If there is no jam, proceed to step 2. 2. Remove cards from hopper. 3. Press NPRO key. 4. Place card just run out ahead of cards from hopper, and place this deck in hopper. 5. Press 2501 start key.
<p>Ready Light on Read-Check Light on Sense Bit 3 - Equipment Check</p>	<ol style="list-style-type: none"> 1. Error card is last card in stacker. Correct any off-punching it contains. Place corrected card as last card in stacker. 2. Remove cards from hopper. 3. Press NPRO key. One card should enter stacker. 4. Place last two cards from stacker ahead of cards removed from hopper, and place this deck in hopper. 5. Press start key. 6. Restart program.
<p>Ready Light on Validity-Check Light on Sense Bit 4 - Data Check</p>	<ol style="list-style-type: none"> 1. Error card is last card in stacker. Locate and correct invalid punching it contains (more than one punch in rows 1 through 7) and replace it as last card in stacker. 2. Follow steps 2-6 of Sense Bit 3-Equipment Check procedure (one procedure back in this chart).
<p>Ready Light on Sense Bit 5 - Overrun</p>	<ol style="list-style-type: none"> 1. Follow steps 2-6 of Sense Bit 3 - Equipment Check procedure (two procedures back in this chart).

2520 CARD READ PUNCH

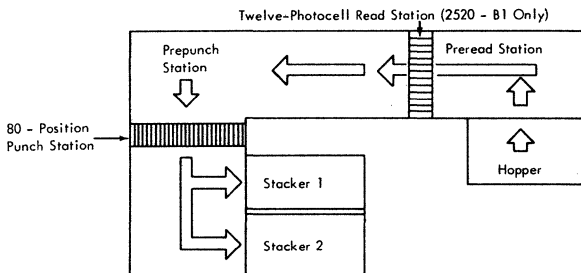

Ready indicates that the 2520 can accept and execute a command from the program. The Ready light is on when these conditions are met:

1. Power on.
2. Cards in hopper and preread station (initial load) or End-of-File light on and card in preread station.
3. Stackers not full.
4. Chip box properly positioned and not full.
5. Feed check light off.
6. Covers and other machine interlocks closed.
7. Punch unit locked in place.
8. Stop key not pressed. (If all other conditions for ready are met and the Stop key has been pressed, pressing the Start key turns on the Ready light.)

Validity Check indicates that the 2520-B1 read more than one punch in rows 1 through 7 of a card column during a data mode 1 read operation.

Jam Removal

When jammed cards must be removed manually, the operator can gain access to the transport and punch unit by opening the top covers of the 2520. The transport area has a hinged plastic card-guide that can be raised, and a pressure-release lever that frees cards in the read station. The punch area is entirely exposed by unlatching and raising the punch unit.

By turning a hand-feed wheel, the operator can manually advance the mechanical portions of the punch area as an aid to jam removal. After clearing a jam from the punch area, the operator should always pass a blank card through the punch die and under the punch area pressure rolls to determine that all card scraps have been removed.

NOTE: Restart procedures vary according to type of command issued. Refer to the component description manual SRL A21-9027.

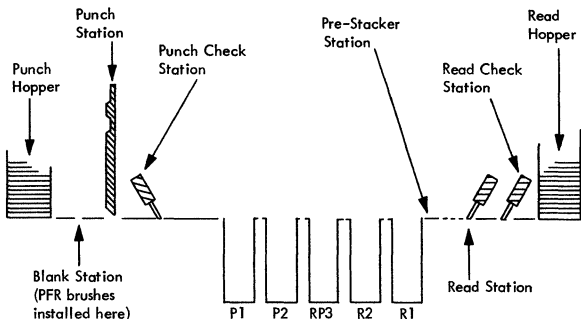

Lights

As an aid to the programmer and the operator in planning restart methods, the following descriptions of error lights include the associated 2540 sense indications.

Reads

Feed Stop (Sense-Bit 1, Intervention Required) turned on when the reader motor is stopped by a card jam, a misfeed, a read clutch failure, or a failure to receive a signal from the 2821 after a read cycle is completed. Feed Stop is turned off by performing a non-process runout.

Read Check (Sense-Bit 3, Equipment Check) signals detection of a hole-count, a parity error, an addressing error, or a translate check in the 2821 read buffer. Read Check is also turned on by a read clutch failure. Read Check is turned off by the next read command.

Ready Indicates that the reader is in ready status.

Validity Check (Sense-Bit 4, Data Check) indicates that an invalid punch configuration (more than one punch in rows 1-7 of a single column) has occurred in a read or PFR data-mode 1 operation. Validity Check is turned off by the next command.

End-of-File indicates that the end-of-file key has been pressed, and that the end-of-file circuits are active. The end-of-file light goes out and the circuits are deactivated if the stop key is pressed, or if the last card has been stacked and an additional feed instruction, or read and feed instruction, has been received by the reader.

Punch

Chips (Sense-Bit 1, Intervention Required) indicates that the chip box is either full, or improperly positioned.

Ready indicates that the punch is in Ready status.

Punch Check (Sense-Bit 3, Equipment Check) indicates the detection of a hole-count error, parity check, addressing error, or translate check in the 2821 buffer. Punch Check is also turned on if these errors occur during a PFR Read operation or any time a punch clutch error occurs. This indication is reset by the next command.

Feed Stop (Sense-Bit 1, Intervention Required) is turned on when the punch motor is stopped by a card jam, a misfeed, or a punch-clutch failure. Feed Stop is turned off by performing a non-process runout.

End-of-File (installed in the punch feed only when the 2540 is equipped with the special feature) turns on when the punch end-of-file key has been pressed, activating the punch-feed end-of-file circuits. If the punch stop key is pressed, the punch end-of-file light will go out and the circuits will be deactivated.

Validity Check (Sense-Bit 4, Data Check) indicates more than one punch in rows 1 through 7 in same column while operating in data mode 1. This light is installed with the PFR feature only. It is reset with the next command.

Common Indicator Lights

Transport (Sense-Bit 1, Intervention Required) indicates a card jam in the transport area of the 2540. This light goes out when the jam is cleared and the covers are closed.

Power indicates that the 2540 is being supplied with dc power.

Stacker (Sense-Bit 1, Intervention Required) indicates that any one of the five stackers is filled.

Fuse indicates that a signal fuse in the 2540 has blown. A blown fuse must be replaced by a fuse of the same size. An IBM Customer Engineer should be notified whenever a fuse has blown, because this could indicate a malfunction in the 2540 circuitry.

OPERATING AND RESTART PROCEDURES

Initial Start

To begin operation with the 2540 reader:

1. Perform an NPRO operation by opening the jogger gate, emptying the hopper, and pressing and holding the reader start key to ensure that no cards are left in the feed.
2. Load the desired cards into the hopper or the file-feed magazine, and close the jogger gate. Card decks less than one inch thick should be placed directly in the hopper with the card weight; larger decks can be placed in the file-feed magazine.
3. Press the reader start key.

To begin operation with the 2540 punch:

1. Perform an NPRO operation by emptying the hopper and pressing and holding the punch start key.
2. Load the desired cards into the punch hopper.
3. Press the punch start key.

Restarts from Error Conditions

The 2540 uses the flexible System/360 command set; therefore, different external error conditions can each require different restart procedures, depending on whether the 2540 operation is reading, punching, or PFR. If the program provides some programmed message to indicate the 2540 sense conditions, (timeout, printout, system console display, etc.) the operator can use this message to determine which specific restart procedure he should follow. To locate the error card for read-check and validity-check errors, the operator should be familiar with the type of processing used by the program: that is, whether the program is reading and stacking each card with a single command, or delaying the stacker selection until the data from the card is analyzed.

Pages 90-97 show the various 2540 error indications and appropriate restart procedures for standard operations, for PFR operations and for 1400 Compatibility-mode operations. The procedures on pages 94-97 assume that the I/O-Check-Stop bit has been turned on with card 0390 of the compatibility initialization deck. External indications and channel indications are included in both figures. The programmer should display the sense indications to the operator.

NOTE: The punch end-of-file key, installed as part of the 2540 Punch-Feed-Read special feature, should not be used (1) when the program does not issue the PFR Read command for the last card of the file, or (2) for 1400 Compatibility operations. Improper use of this key can cause the 2540 to lose one or two punched-card output records.

Jam Removal

The operator can gain access to the top of the read feed, transport and stacker area, and punch feed by raising the top covers of the 2540. He can remove the read-check brushes, the read brushes, the punch-check brushes, and the PFR brushes, as necessary, to free jammed cards.

If brushes must be removed, avoid contact between the brushes and any other part of the machine. Such contact can damage the brushes or blow a fuse. When replacing these brushes be sure to hand crank the Feed as you are seating the brush block into position. To hand crank the Feed, open the right front door of the reader and turn the hand wheel clockwise.

The locking pins should be snapped into place before a restart is attempted. A series of reader checks or punch checks upon restarting could indicate damaged or improperly positioned brushes.

Jams in the punch unit could require the operator to open the front cover of the punch feed, crank the punch clutch to a setting between 335° and 350°, remove the plastic chip funnel, and lower and remove the punch die. The die has a handle shaped like an inverted T. The operator must turn this handle clockwise until the lock at the top of the die is released, and, if necessary, trip the ejection trigger on the handle to remove the die from the machine.

When all cards and card fragments have been removed from the punch unit, the operator replaces the die by pushing it up into the punch unit, and turning the handle counterclockwise. The die is improperly seated if a light tug on the handle causes it to fall.

A decal on the plastic cover over the punch clutch has instructions for the operator to follow in removing jams from the punch unit.

2540 RESTART PROCEDURES - STANDARD AND PFR OPERATION

INDICATIONS	RESTART PROCEDURES
<p>Reader Feed Stop Light (Only) Sense Bit 1--Intervention Required (Only)</p> <p>NOTE: If read check/bit 3 or validity check/bit 4 indications accompany feed stop/bit 1, follow procedure for read check or validity check.</p>	<ol style="list-style-type: none"> 1. Remove cards from stacker R1. 2. Open hopper jogger gate and remove cards from hopper. 3. Open covers and remove any jammed cards from read feed. Reconstruct any damaged cards. 4. If EOF is on, press stop switch to reset EOF. 5. With jogger gate still open, press and hold reader start key to clear feed. 6. Remove cards just run out into stacker R1, place them and any reconstructed cards, in proper sequence, ahead of cards removed from hopper, and replace this deck in hopper or ahead of cards in file feed magazine. 7. Close jogger gate. 8. Press reader start key.
<p>Reader Feed Stop Light Read Check Light Sense Bit 1--Intervention Required (Only)</p>	<p>This combination of error indications accompanies a 2540 read clutch failure; there may be cards in stacker R1 that have not been read. Restart the job from the last checkpoint. The CE should be advised when this error occurs.</p>
<p>Read Check Light Sense Bit 3--Equipment Check</p> <p>(If card is read and stacked with single command.)</p>	<ol style="list-style-type: none"> 1. Remove cards from stacker R1. Determine (perhaps with aid from programmed message) which was last card read into processing unit, and correct any off-registration punching in it. Place this corrected card in stacker R1. 2. Open jogger gate and remove cards from hopper. 3. If EOF is on, press stop switch to reset EOF. 4. With jogger gate open, press and hold reader start key to clear read feed. 5. Remove cards from stacker R1 and place them ahead of cards removed from hopper. Place this deck in hopper or ahead of cards in file feed magazine. 6. Close jogger gate. 7. Press reader start key.
<p>Read Check Light Sense Bit 3 - Equipment Check</p> <p>(If stacker selection is delayed).</p>	<ol style="list-style-type: none"> 1. Remove cards from stacker R1. 2. Follow steps 2-7 of preceding procedure, correcting any off-registration punching in first card run out into stacker R1.

INDICATIONS	RESTART PROCEDURES
<p>Validity Check Light Sense Bit 4--Data Check</p> <p>(If card is read and stacked with single command.)</p>	<ol style="list-style-type: none"> 1. Remove cards from stacker R1. Determine (perhaps with aid from programmed message) which was last card read into processing unit (this card may be in another stacker) and correct any errors in this card. Place the corrected card in stacker R1. 2. Open juggler gate and remove cards from hopper. 3. If EOF is on, press stop switch to reset EOF. 4. With juggler gate open, press and hold reader start key to clear read feed. 5. Remove cards from stacker R1 and place them ahead of cards removed from hopper. Place this deck in hopper or ahead of cards in file feed magazine. 6. Close juggler gate. 7. Press reader start key.
<p>Validity Check Light Sense Bit 4--Data Check</p> <p>(If stacker selection is delayed.)</p>	<ol style="list-style-type: none"> 1. Remove cards from stacker R1. 2. Open juggler gate and remove cards from hopper. 3. If EOF is on, press stop switch to reset EOF. 4. With juggler gate open, press and hold reader start key to clear read feed. 5. Locate and correct invalid character(s) in first card in stacker R1. 6. Place corrected card ahead of cards in stacker R1. Place all cards in stacker R1 ahead of cards removed from hopper. Place this deck in hopper or ahead of cards in file feed magazine. 7. Close juggler gate. 8. Press reader start key.
<p>Validity Check Light Punch Check Light Sense Bit 3--Equipment Check Sense Bit 4--Data Check</p> <p>(If 2540 is performing PFR read operation.)</p>	<ol style="list-style-type: none"> 1. Remove card from punch hopper. 2. If EOF is on, press stop switch to reset EOF. 3. Press and hold punch start key to clear punch feed. 4. Remove last three cards from stacker P1. 5. The first of these three cards may have to be reconstructed because it has been read and punched but not punch checked. 6. The second card caused the validity check. Correct it as necessary. 7. Place these three cards, after any necessary corrections, in front of the cards removed from the hopper. Place this deck in the hopper. 8. Press the punch start key. 9. Reconstruct internal data in the system as necessary to restart at the Start I/O instruction that caused the reading of the first card run out of the punch feed in step 3. <p>NOTE: In some programs, reconstruction of internal data may not be provided for. In that case, restart the job from the last checkpoint.</p>

2540 RESTART PROCEDURES - STANDARD AND PFR OPERATION

INDICATIONS	RESTART PROCEDURES
<p>Punch Feed Stop Light (Only) Sense Bit 1--Intervention Required (Only)</p> <p>(If the 2540 is not performing PFR operations.)</p>	<ol style="list-style-type: none"> 1. Remove cards from stacker P1. 2. Remove cards from hopper. 3. Open covers and remove any jammed cards from punch feed. 4. Press and hold punch start key to clear punch feed. 5. Discard last card punched (2540 will repunch this card automatically). 6. Replace blank cards in hopper and press punch start key. Last card will be repunched automatically and 2540 enters ready status.
<p>Punch Feed Stop Light (Only) Sense Bit 1--Intervention Required (Only)</p> <p>(If 2540 is performing PFR operation.)</p>	<ol style="list-style-type: none"> 1. Remove cards from stacker P1. 2. Remove cards from hopper. 3. If EOF is on, press stop switch to reset EOF. 4. Open covers and remove any jammed cards from punch feed. Press and hold punch start key to clear feed. 5. Any card removed or run out from between punch station and punch check brushes should be reconstructed, because it has been punched but not punch checked. 6. Place reconstructed cards and cards run out into stacker P1, in proper sequence, ahead of cards removed from hopper, and place this deck in hopper. 7. Press punch start key. 8. Reconstruct internal data in the system as necessary to restart at the Start I/O instruction that caused the first card removed or run out to be read at the PFR station. <p>NOTE: In some programs, reconstruction of internal data may not be provided for. In that case, restart the job from the last checkpoint.</p>
<p>Punch Check Light Sense Bit 3--Equipment Check</p> <p>(If 2540 is not performing PFR operation and is using stacker P1.)</p>	<ol style="list-style-type: none"> 1. Remove cards from hopper. 2. Press and hold punch start key to clear punch feed. 3. Remove last four cards from stacker P1. The last two cards are blank; the first two should be discarded. 4. Replace blank cards and cards removed from hopper in hopper. 5. Reconstruct internal data in the system as necessary to restart at the Start I/O instruction that caused the first card removed from stacker P1 to be punched. <p>NOTE: In some programs, reconstruction of internal data may not be provided for. In that case, restart the job from the last checkpoint.</p>

2540 RESTART PROCEDURES - STANDARD AND PFR OPERATION

INDICATIONS	RESTART PROCEDURES
<p>Punch Check Light Sense Bit 3--Equipment Check</p> <p>(If 2540 is not performing PFR operation and is not using stacker P1.)</p>	<ol style="list-style-type: none"> 1. Examine and correct, if necessary, error card, which is last card in stacker P1. (2540 automatically routes error cards to stacker P1.) 2. Place this card in appropriate stacker. 3. Press and hold punch start key to clear feed. 4. The 2540 will force the card following the error card into stacker P1, also. Place this card in the appropriate stacker. <p>NOTE: Because the error card and the card following it are both directed to stacker P1, the program can correct a non-PFR punch check without operator intervention by repunching both cards and directing them to appropriate stackers. The operator can then discard all cards in stacker P1 at the end of the job.</p>
<p>Punch Check Light Sense Bit 3--Equipment Check</p> <p>(If 2540 is performing PFR operation.)</p>	<ol style="list-style-type: none"> 1. Remove cards from punch hopper. 2. If EOF is on, press stop switch to reset EOF. 3. Press and hold punch start key to clear feed. 4. Remove last four cards from stacker P1. The last two cards are correct; pre-punching in the first two must be reconstructed. 5. Place the two reconstructed cards, the two correct cards, and the cards removed from the hopper, in that sequence, in the hopper. 6. Reconstruct internal data in the system as necessary to restart at the Start I/O instruction that caused the first reconstructed card to be read at the PFR station. <p>NOTE: In some programs, reconstruction of internal data may not be provided for. In that case, restart the job from the last checkpoint.</p>
<p>Punch Feed Stop Light Punch Check Light Sense Bit 1--Intervention Required (Only)</p>	<p>This combination of error indications accompanies a 2540 punch clutch failure; there may be cards in stacker P1 that have not been processed. Restart the job from the last checkpoint. The CE should be advised when this error occurs.</p>



2540 RESTART PROCEDURES - 1400 COMPATIBILITY

INDICATIONS	RESTART PROCEDURES
<p>Reader Feed Stop Light (Only) System Console Main Storage Data Register (MSDR) Display: 4F</p>	<ol style="list-style-type: none"> 1. Remove cards from stacker R1. 2. Open jogger gate and remove cards from read hopper. 3. Open covers and remove any jammed cards from read feed. 4. If EOF is on, press stop switch to reset EOF. 5. With jogger gate still open, press and hold reader start key to clear feed. Any damaged cards must be reconstructed. 6. Remove cards just run out into stacker R1. Place them and any reconstructed cards, in proper sequence, ahead of cards removed from hopper, and place this deck in hopper or ahead of cards in file feed magazine. 7. Close jogger gate. 8. Press reader start key. 9. Press system console start key.
<p>Reader Feed Stop Light Read Check Light System Console MSDR Display: 3F</p> <p>(If there is no card jam in the 2540 read feed.)</p>	<p>This combination of error indication accompanies a 2540 read clutch failure; there may be cards in stacker R1 that have not been read. Restart the job from the last checkpoint. The CE should be notified if this error reoccurs.</p>
<p>Reader Feed Stop Light Read Check Light System Console MSDR Display: 3F</p> <p>(If there is a jam in the 2540 read feed.)</p>	<p>Follow the procedure for read check or validity check (the next procedure in this chart).</p>
<p>System Console MSDR Display: 3F</p> <p>(Read check or validity check has occurred, but the light has been turned off.)</p> <p>NOTE: This same indication can occur for PFR operation; see that procedure later in this chart if appropriate.</p>	<ol style="list-style-type: none"> 1. The last card in stacker R1 is error card. Correct it. 2. Open jogger gate and remove cards from hopper. 3. If EOF is on, press stop switch to reset EOF. 4. With jogger gate open, press and hold reader start key to clear feed. 5. Place corrected card ahead of the three cards just run out into stacker R1. Place these four cards ahead of the cards removed from the hopper, and place this deck in the hopper or ahead of the cards in the file feed magazine. 6. Close jogger gate. 7. Press reader start key. 8. Press system console start key.

2540 RESTART PROCEDURES - 1400 COMPATIBILITY

INDICATIONS	RESTART PROCEDURES
<p>Punch Feed Stop Light (Only) System Console MSDR Display: 5F</p> <p>(If 2540 is not performing PFR operation.)</p>	<ol style="list-style-type: none"> 1. Remove cards from stacker P1. 2. Remove cards from punch hopper. 3. Open covers and remove any jammed cards from punch feed. 4. Press and hold punch start key to clear feed. 5. Discard last card punched (2540 will repunch this card automatically). 6. Replace blank cards in hopper and press punch start key. Last card will be repunched. 7. Press system console start key.
<p>Punch Check Light (Punch feed stop light may be on or off.) System Console MSDR Display: 5F</p> <p>(If 2540 is not performing PFR operation.)</p>	<ol style="list-style-type: none"> 1. The last card in stacker P1 caused the punch check. Correct it as necessary. Place corrected card in appropriate stacker. 2. Press system console start key. <p>NOTE: If no jam condition exists and the punch check light and punch feed stop light are both on, a punch clutch error has occurred. The program should be restarted from the last checkpoint. The CE should be advised when this error occurs.</p>



2540 RESTART PROCEDURES - 1400 COMPATIBILITY

INDICATIONS	RESTART PROCEDURES
<p>System Console MS DR Display: 3F Punch Check Light and Validity (Check light may be on or off)</p> <p>(If 2540 is performing PFR Operation)</p>	<ol style="list-style-type: none"> 1. Remove cards from punch hopper. 2. If EOF is on, press stop switch to reset EOF. 3. Press and hold punch start key to clear feed. 4. Remove last three cards from Stacker P1. 5. The first of these three cards must be reconstructed because it has been read and punched but not punch checked. 6. The second card caused the error; correct it as necessary. 7. Place reconstructed card 1, corrected card 2, and card 3 in front of the cards removed from the hopper. At the front of this deck place a readily-identifiable blank card, and place this deck in the hopper. 8. Reconstruct internal data in the system as necessary to restart at the instruction that caused card 1 to be read at the PFR station. NOTE: In some programs, reconstruction of internal data may not be provided for. In that case, restart the program from the last checkpoint. Be sure that the readily identifiable blank card is the first card in the hopper. 9. Set the system console process switch at SINGLE CYCLE. 10. Set address 10 FF in switches F, G, H, and J on the system console. 11. Press the system reset key. 12. Press ROAR reset key. 13. Press system console start key. 14. Set system console process switch at PROCESS. 15. Press 2540 punch start key. 16. At system console, perform Set IC function to address appropriate instruction. See <u>Operator's Guide</u> for the appropriate system. 17. Press system console start key to resume processing. 18. Remove readily-identifiable blank card inserted in step 7 when it is stacked. This card may now be punched; if it is, discard it.

2540 RESTART PROCEDURES - 1400 COMPATIBILITY

INDICATIONS	RESTART PROCEDURES
<p>Punch Feed Stop Light (Only) System Console MSDR Display: 5F</p> <p>(If 2540 is performing PFR operation.)</p>	<ol style="list-style-type: none"> 1. Remove cards from stacker P1. 2. Remove cards from punch hopper. 3. Open covers and remove any jammed cards from punch feed. 4. If EOF is on, press stop switch to reset EOF. 5. Press and hold punch start key to clear feed. 6. Any cards removed or run out from between punch station and punch check brushes have been punched but not punch checked. Pre-punching in these cards should be reconstructed. 7. Place any reconstructed cards and cards run out into stacker P1, in proper sequence, ahead of cards removed from hopper. Place a readily-identifiable blank card ahead of this deck and place deck in hopper. 8. Perform steps 8-18 of preceding procedure in this chart.
<p>Punch Check Light (Punch feed stop light may be on or off)</p> <p>(If 2540 is performing PFR operation.)</p>	<ol style="list-style-type: none"> 1. Remove cards from punch hopper. 2. If punch feed stop light is on, open covers and remove any jammed cards from punch feed. Correct any damaged cards. 3. If EOF is on, press stop switch to reset EOF. 4. Press and hold punch start key to clear feed. 5. Of the last four cards to enter the 2540 punch feed, the last two are correct and pre-punching in the first two must be reconstructed. 6. Place a readily-identifiable blank card, the two reconstructed cards, the two correct cards, and the cards removed from the hopper in the hopper. 7. Perform steps 8-18 of PFR punch validity check procedure (two procedures back in this chart). <p>NOTE: If no jam condition exists and the punch check light and punch feed stop light are both on, a punch clutch error has occurred. The program should be restarted from the last checkpoint. The CE should be advised when this error occurs.</p>



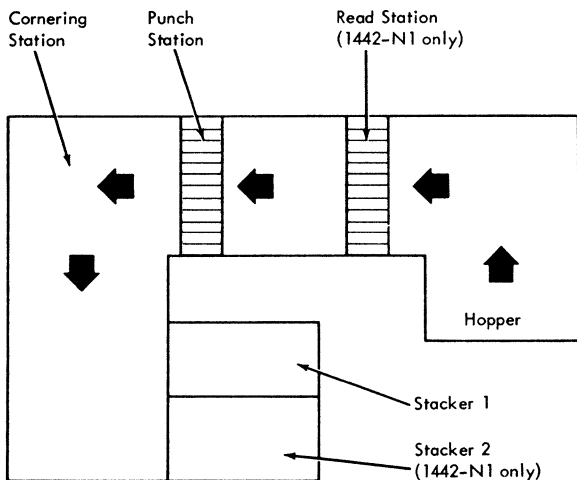

Ready indicates that the 1442-N1 can perform a command received from the channel. Pressing the start key turns on the ready light if these conditions are met:

1. There are cards in the hopper and at the read station, or the end-of-file light is on.
2. The chip box is in place and not full.
3. Neither stacker is full.
4. All covers are closed.
5. There are no hopper, read station, punch station, transport, or feed clutch error lights.
6. There is no outstanding status present in the 1442-N1 that has not been accepted by the processing system.

NOTE: Pressing the stop key causes ready status to drop. If the power is on and Ready is not on, the 1442-N1 replies with Unit Check status to any command except the Sense command.

Pressing the start key causes the 1442-N1 to present Device End to the Channel. When Device End is accepted, the Ready light turns on.

Check indicates that at least one error condition is displayed on the back-lighted indicator panel.

Intervention Required - Operator action is necessary to empty stacker, fill hopper, empty chip box, clear jam, restore ready status.

Unit Exception - (1442-N1 Only) The 1442-N1 has received a Read command when there are no cards in the hopper or the read station, the End of File key has been pressed, and the last card is registered in the punch station. Channel End accompanies Unit Exception.

Restart Procedures

The recovery from an I/O error depends upon the command issued and is too complicated to summarize in this handbook. We suggest you refer to the SRL Manual for the 1442-N1, Form A21-9025.

CARD READERS - GENERAL

1. A common cause of read checks is off punched or worn cards.
2. Use a card gauge to determine off punching.
3. A validity check usually indicates a double punch in rows 1-7 of the Card.
4. When bringing new cards into the computer room from a different environment (heat, humidity), do not use them for the first 12 hours.
5. Cards do wear out. Reproduce master decks when you notice excessive marking or scoring on the edges.
6. Some common sense messages that may type out on the console are:

Intervention Required - Operator attention is needed to empty the stacker, fill the hopper, press END OF FILE, clear the transport, close a cover, or restore ready status. This indication also accompanies a read station failure that occurs during reading.

Equipment Check - Indicates that the two readings of a column did not agree. Also indicates that the read station failed before reading begins.

Data Check - Indicates that the machine has detected an invalid card column (more than one punch in rows 1-7) in data mode 1.

O/S PCP and MFT-I CommandsPCP System

CANCEL	SET
DISPLAY	START
MOUNT	STOP
REPLY	UNLOAD
REQ	VARY

Console commands, other than SET and START, are accepted whenever you issue them. To issue a SET or START command, first issue a REQ command. A REQ command makes the system pause and issue a message requesting further commands at the end of a job step. Any commands issued in response to such a message must be followed by a START command with no parameters. This command gives control to the reader to start the next job step.

The following conventions are used in illustrating the format of commands:

- Required letters (those shown in upper case) must be entered in either upper or lower case.
- Lower-case letters indicate that a parameter must be substituted.
- Dotted lines . . . (indicating a series of terms), brackets [], and braces { } are not entered.
- Entries within brackets [] are optional.
- Entries within braces { } are required - you must select one.
- Numbers and punctuation marks (other than dotted lines, brackets, and braces) must be entered as shown.

Command formats are essentially free form, but one or more blanks must follow the operation field. Commands cannot occupy more than one line. For example, if a command is entered through a card reader, it may not be more than 80 characters in length.

If comments on commands are necessary, they should appear to the right of the operand field and be separated from it by at least one blank. If the operand field is null, a comma followed by at least one blank indicates that comments will follow.

CANCEL -- Terminate Job Immediately

Operation	Operand
{CANCEL} C	jobname [,DUMP]

jobname

specifies the name of the job to be terminated. The maximum length of a job name is eight characters.

DUMP

specifies that an abnormal-end-of-task storage dump is to be taken if a step of the job is being executed when the command is received. If the programmer has put in the SYSABEND data definition statement, a full dump is taken. If he has not included this card, an indicative (partial) dump is taken.



DISPLAY -- Cause Console Display

Operation	Operand
{ Display } D	{ JOBNAMES [, T] } { STATUS } { DSNAME } { SPACE }

JOBNAMES [, T]

the name of each job is to be displayed both when the job starts and when it ends, and that unit record allocation is to be displayed when the step starts.

If a job terminates abnormally, the job names will appear in the diagnostic message.

If the T parameter is used in conjunction with the JOBNAMES parameter, the system displays the time of the day in addition to the jobnames.

STATUS

the data set names and volume serial numbers of data sets with dispositions of KEEP, CATLG, or UNCATLG are to be displayed on the console at step termination and job termination.

DSNAME

the system is to display, within the mount and K (keep) - type demount messages, the name of the first non-temporary data set allocated to the volume to which the messages refer. Mount messages for data sets with a disposition of DELETE will not contain the data set name.

SPACE

the system is to display, in demount messages, the available space on a direct access volume.

MOUNT -- Allocate Device

Operation	Operand
{ MOUNT } M	unitaddr [, VOL=(NL, serial)] [, USE= { STORAGE } { PUBLIC } { PRIVATE }]

Unitaddr

specifies the name of the input/output device to be allocated. Unitname must specify a device that has been unloaded by the system.

VOL=(NL, serial)

specifies that the volume does not have standard labels. The alphameric serial number, up to six characters long, is used for allocation references. This parameter is not used for direct-access volumes.

USE=STORAGE or PUBLIC or PRIVATE

specifies that a direct-access volume will be used as either a storage volume or a public volume or a private volume. If this operand is not used, the system treats the volume as a private volume. A storage volume is the most freely allocated kind of volume, open to use by the largest variety of data sets, temporary or non-temporary. Slightly restricted is a public volume, which can be allocated freely for temporary data sets, but which must be specified by volume serial number to be allocated to non-temporary data sets. A private volume is the least freely allocated kind of volume -- it is allocated only if its volume serial number is specified.

REPLY -- Reply to Information Request

Operation	Operand
{ REPLY } R	id, 'text'

id

specifies the 2-character message identification field of the message requesting the reply.

text

specifies the text to be entered in response to a message. The information passed to the program expecting the reply does not include the enclosing apostrophes. When using the REPLY command to answer system messages, always be sure to use upper case letters in the text.

REQ -- Request Commands

Operation Operand

REQ

SET -- Set Date, Time, and Location

Operation	Operand
{ SET } { T }	DATE=yy.ddd ,CLOCK=hh.mm.ss ,Q=(unitname ,F) , PROC=unitname

DATE=yy.ddd

specifies the date in the following format:

```
yy.ddd
 |
 |--- days (001-366)
 |--- Year (00-99)
```

CLOCK=hh.mm.ss

specifies the time of day in the following format:

```
hh.mm.ss
 |
 |--- Seconds (00-59)
 |--- Minutes (00-59)
 |--- Hours (00-23)
```

If the new clock setting implies a change of date, the new date must be explicitly stated using the DATE parameter.

Q=(unitname[, F])

specifies the name of the direct-access device on which the volume containing the input work queue (SYS1. SYSJOBQE) is to reside (do not specify a 2321 data cell in this operand). The F is a request to the system to format the queue prior to the first job initiation; it must be used during the first IPL, but need not be used at subsequent IPLs.

PROC=unitname

specifies the name of the direct-access device on which the volume that contains the procedure library resides. If this parameter is not given, the system assumes that the procedure library is on the system residence volume. (This parameter is used only in the initial SET command issued immediately after IPL and should only specify a device that is ready.)

START -- Start System Process

Operation	Operand
{ START S }	[RDR], unitname, [WTR] [volumeserial], [parmvalue], [DSN=datasetname,] [FILESEQ=file sequence number]

RDR

specifies that an input reader is to be started.

WTR

specifies that an output writer is to be started.

unitname

specifies the name of the unit record or magnetic tape input/output device associated with the input reader or output writer that is to be started.

volumeserial

specifies the alphanumeric serial number, up to six characters long, of a magnetic tape volume. If this parameter is specified, label checking is performed.

parmvalue

specifies either an up-to-eight-character name of a job in the input stream or a one-character alphanumeric output class name. A job name is used only with RDR: when starting an input reader, giving the job name causes forward spacing through the input stream until the named job is found. An output class name is used only with WTR: Giving a class name indicates the class of output the writer is to handle; if no class is specified, the writer is assigned to class A.

DSN=datasetname

specifies the name of the data set associated with the input reader or output writer. The maximum length of a data set name is 44 characters. If this parameter is not specified, the data set name SYSIN is assumed for the reader.

FILESEQ=file sequence number

specifies the file sequence number, up to four digits long, of a data set on a magnetic tape volume. This parameter is optional and is used only with RDR when unitname designates a magnetic tape device.

Operation	Operand
{ STOP } P	{ JOBNAMEs WTR,unitaddr STATUS DSNAME SPACE }

JOBNAMEs

a console display of the names of jobs, initiated by the JOBNAMEs parameter of the DISPLAY command, is to be terminated. For more information about JOBNAMEs, see the discussion of the DISPLAY Command.

WTR,unitaddr

the output writer using the addressed unit is to be stopped by the system. This operand will not stop a writer assigned to Class A or B -- only a new START WTR to Class A or B will cause the presently active one to stop.

STATUS

the system is to stop the console display at step termination and job termination of the names and volume serial numbers of data sets with dispositions of KEEP, CATLG, or UNCATLG.

DSNAME

the system is to stop the display of the names of non-temporary data sets as initiated by the DSNAME parameter of the DISPLAY command. For more information, see the discussion of the DISPLAY command.

SPACE

the system is to stop displaying, in demount messages, the available space on a direct access volume. (The display was initiated by the SPACE parameter of the DISPLAY command.)

UNLOAD -- Prepare Volume for Dismounting

Operation	Operand
{ UNLOAD } U	unitaddr

unitaddr

specifies the unit address of the input/output device to be prepared for dismounting.

VARY -- Vary Status of Device

Operation	Operand
{ VARY } V	unitaddr, ONLINE , OFFLINE

unitaddr

specifies the unit address name of the input/output device whose status is to be changed.



ONLINE

specifies that the device is to be made available for allocation by the job scheduler to problem programs.

OFFLINE

specifies that the device is to be removed from the recognition of the job scheduler, and that any further allocation of the device to problem programs is to be prevented.

MVT and MFT Systems

In systems with MVT, all commands can be entered at any time. For example, the VARY command can be used before the initial SET command.

In systems with MVT, you can use abbreviations as well as the full command name when keying in your commands. The usable names and abbreviations are:

CANCEL	C	MOUNT	M
DEFINE	N-MFT	RELEASE	A
	only	REPLY	R
DISPLAY	D	RESET	E
HALT	Z	SET	T
HOLD	H	START	S
LOG	L	STOP	P
MODE		UNLOAD	U
MODIFY	F	VARY	V
MONITOR	MN	WRITELOG	W

Be sure to use the correct abbreviations for operator commands. For example, use S for START and T for SET. If you inadvertently key in S for SET, the system assumes you are giving a START command, queues the command, and waits for a SET command.

The following conventions are used in illustrating the format of commands:

- Required letters (those shown in upper case) must be entered in either upper or lower case.
- Lower-case letters indicate that a parameter must be substituted.
- Dotted lines . . . (indicating a series of terms), brackets [], and braces { } are not entered.
- Entries within brackets [] are optional.
- Entries within braces { } are required - you must select one.
- Numbers and punctuation marks (other than dotted lines, brackets, and braces) must be entered as shown.

Command formats are essentially free form, but one or more blanks must follow the operation field. Commands cannot occupy more than one line. For example, if a command is entered through a card reader, it may not be more than 80 characters in length.

If comments on commands are necessary, they should appear to the right of the operand field and be separated from it by at least one blank. If the operand field is null, a comma followed by at least one blank indicates that comments will follow.



CANCEL -- Terminate Job Immediately

Operation	Operand
{ Cancel } C	$\left(\begin{array}{l} \text{jobname} \\ \text{identifier} \end{array} \left[\begin{array}{l} [,DUMP] [, ALL] \\ IN[=class] \\ OUT[=class] \end{array} \right] \right)$

jobname

the name of the job (process) to be terminated. The jobname is the name of a job from the system input stream.

DUMP

specifies that an abnormal-end-of-task storage dump is to be taken if a step of the job is being executed when the command is received.

ALL

all system input and/or system output for the specified job is canceled.

IN=class

the system will search for the job on the input queue specified by the class parameter. If IN is used without the class parameter, all input queues will be searched for the job.

OUT=class

the system will search for the job on the output queue specified by the class parameter. If OUT is used without the class parameter, all output queues will be searched for the job.

identifier

the identifier, from the START command, of the system task to be terminated during device allocation or the job started from the console.

The following can be used to cancel a system task in the device allocation process:

- The identifier used in the START command.
- The unit type (e.g., 1403 or 2311) associated with a unit address in the START command.
- The unit type associated with a catalogued procedure, in SYS1.PROCLIB, started by the START command.

For MFT the identifier for a job started from the console is the partition number in which it is run.

DEFINE -- Invoke Dynamic Partition

Definition



Use the DEFINE command after nucleus initialization to change the size and description of any partition while unaffected partitions continue processing. This command cannot be entered into the input stream.

Operation	Operand
{ DEFINE } { N }	[LIST]

LIST

specifies that the current partition definitions will be listed. Job classes associated with currently active partitions and, if time-slicing is used, the time-slicing specifications are listed also.

CAUTION: When using the time-slicing option, do not define job classes across the boundaries between a time-sliced group of partitions and partitions that are not time-sliced. For example, don't specify a partition with job classes A, B, C in a time-sliced group, and a partition with job classes C, D, E outside the group. Doing so would allow a job in class C to be put either inside or outside the time-sliced group regardless of the intentions of the programmer of that job.

DISPLAY -- Cause Console Display

Operation	Operand
{ DISPLAY } D	T A U [,TP ,GRAPHIC ,TAPE ,DASD ,UR] [,ONLINE] [,xxx] [,nnn] R Q [=LIST] N [=LIST] jobname C,K CONSOLES

- T
the time of day and the date are to be displayed.
- A
the system is to display information about all the jobs and job steps recognized by the supervisor as tasks.
- U
a listing of the Unit Status information about the devices indicated is to be displayed.

Unit status can be displayed about the following device types:

- | | |
|---------|-------------------------------|
| TP | communication equipment |
| GRAPHIC | graphic devices |
| TAPE | magnetic tape units |
| DASD | direct access storage devices |
| UR | unit record devices |

If you do not specify a device type, the unit status of all devices in the system will be displayed.

- R
the system is to display:
- The ID of each message that requires a reply and has not yet been replied to.
 - The unit address of each device for which a mount message has been issued but has not been complied with.
 - An indication if any AVR mount messages are pending.
- Q
A listing of the number of entries on each of the non-empty input, hold, output and RJE queues is to be displayed.
- N
A listing of jobnames on the hold, input, output, and .JE queues is to be displayed.

list
any combination of up to three of the following items:

- specific input work queue name (job class A through O)
- HOLD (system hold queue)

jobname

the name of the job for which the following are to be displayed: job name; class; job priority; type of queue the job is in.

C,K

the system is to display the control command operands and an explanation of each operand. C,K is valid only for display operator consoles.

CONSOLES

the system's console configuration is to be displayed. Valid only for multiple console support (MCS) option.

Halt -- Prepare for Power-off

Operation	Operand
{ HALT } { Z }	EOD

EOD

specifies that end-of-day storing is to be done of internal I/O device error counts. The information is stored in the SYS1.LOGREC data set.

When the storing is done, the system sends you a message EOD SUCCESSFUL. At this point, you can safely turn the power off.

HOLD -- Temporarily Suspend Job Selection

Operation	Operand
{ HOLD } { H }	{ jobname } { Q [=list] }

jobname

specifies the name of the job whose selection is to be suspended. The maximum length of a job name is eight characters. Although any job name can be in parentheses, a job with the name Q must have the Q in parentheses in the command statement.

Q

specifies that selection of all jobs from the input work queue is to be suspended.

list

any combination of up to four input work queue names (job class A through O). If no list value is specified, all 15 input work queues are assumed. If list includes more than one item, you must separate the specified items by commas and enclose them in parentheses.

LOG -- Store Information in Log

Operation	Operand
{ LOG } { L }	'text'

text

specifies the exact text you wish to enter into the system log. The message written in the system log does not include the enclosing apostrophes.





MODE -- Recovery Management Mode Switching for Models 85, 155, and 165

MODEL 85

Operation	Operand
MODE	$\left\{ \begin{array}{l} \text{STATUS} \\ \text{INIT} \\ \text{HIR, x[, dddddd]} \\ \text{ECC, x[, dddddd]} \\ \text{SECT} = \left\{ \begin{array}{l} \text{n[, n, \dots]} \\ \text{ALL} \\ \text{BUF} \end{array} \right\} \\ \text{HSM} \end{array} \right\}$

STATUS

a message describing the status of machine recovery facilities is to be displayed.

INIT

recovery management functions are to be set to their initial values.

HIR

the Hardware Instruction Retry circuitry is to be set.

ECC

the Error Correction Code circuitry is to be set.

x

the mode to which the HIR or ECC circuitry is to be set; use R to indicate Recording Mode and C to indicate Count Mode.

ddddddd

A new threshold count in decimal.

SECT

a previously deleted and repaired sector of the high speed buffer is to be reactivated.

n

the individual sector(s) to be reactivated.

ALL

all sectors are to be reactivated.

BUF

the entire high speed buffer is to be re-enabled.

HSM

the High speed multiply feature in the Model 85 CPU is to be reactivated.

MODEL 155

Operation	Operand
MODE	$\left\{ \begin{array}{l} \text{STATUS} \\ \text{HIR, x[, eeee] [, tttt]} \\ \text{ECC, x[, eeee] [, tttt]} \end{array} \right\}$

STATUS

a message describing the current status of machine recovery facilities is to be displayed.

HIR

the Hardware Correct Code circuitry is to be set.

x

the mode to which the HIR or ECC circuitry is to be set. Use R to indicate Recording Mode and Q to indicate Quiet Mode.

eeee

a four-digit decimal value to be inserted in the error count threshold. This value is the number of errors that will be allowed in a specified time before the HIR or ECC circuitry is placed in the quiet mode. This parameter is used with the R parameter only; if you omit it, the default error count threshold value will be used.

tttt

a four-digit decimal value to be inserted in the time threshold. This value is the time in hours allowed for a specified number of errors before the HIR or ECC circuitry is placed in the quiet mode. This parameter is used with the R parameter only; if you omit it, the default time threshold value will be used.

MODEL 165

Operation	Operand
MODE	{ STATUS } { RECORD } { QUIET } { ENABLE }

STATUS

the current status of the recovery management facilities is to be displayed.

RECORD

the Model 165 is to go into recording mode.

QUIET

the Model 165 is to go into Quiet Mode.

ENABLE

the high-speed buffer, which had previously been disabled, is to be reactivated.

JOBNAMES[,T]



the name of each job is to be displayed when the job starts and when it terminates. Unit record allocation is to be displayed when the step starts. If a job terminates abnormally, the jobname will appear in the diagnostic message.

If the T parameter is used with the JOBNAMES parameter, the system displays the time of the day in addition to the jobname. In systems with MCS, the time of day is displayed at all consoles.

DSNAME

the system is to display, within the mount and K (keep) type demount messages, the name of the first non-temporary data set allocated to the volume to which the messages refer. Mount messages for data sets with a disposition of DELETE will not contain the data set name.

SPACE

the system is to display, in demount messages, the available space on a direct access volume.

STATUS

the data set names and volume serial numbers of data sets with dispositions of KEEP, CATLG, or UNCATLG, are to be displayed whenever they are freed.

MQUNT -- Allocate Device

Operation	Operand
{ MOUNT M }	{unitaddr } {,VOL=(NL, serial)} {devicename } {,VOL=(SL, serial)} [,USE={ STORAGE PUBLIC PRIVATE }]

unitaddr

specifies the name of the input/output device to be allocated. In systems with MVT, you can specify a loaded or an unloaded device. The system will request that the correct volume be loaded if it is not already mounted.

devicename

specifies the type of device to be allocated. After a device is allocated, you receive a mounting message.

VOL=(NL, serial)

specifies that the volume does not have standard labels. The alphanumeric serial number, up to six characters long, is used for allocation references. This parameter is not used for direct-access volumes.

VOL=(SL, serial)

specifies that the volume has standard labels. The alphanumeric serial number, up to six characters long, is used in label checking and for allocation references.



USE=STORAGE or PUBLIC or PRIVATE

specifies that a direct-access volume will be used as either a storage volume or a public volume or a private volume. If this operand is not used, the system treats the volume as a private volume. A storage volume is the most freely allocated kind of volume, open to use by the largest variety of data sets, temporary or non-temporary. Slightly restricted is a public volume, which can be allocated freely for temporary data sets, but which must be specified by volume serial number to be allocated to non-temporary data sets. A private volume is the least freely allocated kind of volume -- it is allocated only if its volume serial number is specified.

RELEASE -- Make Job Available for Selection

Operation	Operand
{ RELEASE A }	{jobname} {Q [=list]}

jobname

specifies the name of the job to be made available for processing. The maximum length of a job name is eight characters. Although any job name can be in parentheses, a job with the name Q must have the Q in parentheses in the command statement.

Q

specifies that all jobs in the input work queue are to be made available for processing.

list

any combination of up to four input work queue names (job class A through O). If no list value is specified, all 15 input work queues are assumed.

REPLY -- Reply to Information Request

(See reply for PCP Commands.)

RESET -- Change Class or Priority of Job

Operation	Operand
{ RESET E }	jobname {,PRTY=priority} {,CLASS=class } [,OUT=outclass]

jobname

the name of the job whose priority and/or class will be changed. The maximum length of a jobname is eight characters. If as a result of a previous RESET command, a system output class has more than one entry for the same jobname, a new RESET command for the same jobname will apply only to the highest priority entry.

PRTY=priority

the value to which the job's priority is to be set. The value is a two-digit number that may range from a low of 00 to a high of 13.

CLASS=class

the input or output class to which the job is to be moved. If a jobname qualifier is present, class is an output class. If no qualifier is present, class is an input class. Class names are A-O for input (job class), A-X and 0-9 for output (system output class).

OS

NOTE: Both the PRTY and the CLASS parameters can be used in the same RESET command.

OUT=outclass

a system output class from which the job is to be moved, or on which its priority is to be changed. This field contains a one character class identifier A-X, or 0-9.

SET -- Set Date, Time, and Location

Always use the CLOCK operand in systems with MVT. These systems use the data in this operand when they name system data sets. (If you do not use the CLOCK operand, the system sets the clock value to zero.)

Operation	Operand
{SET} { T }	DATE=yy.ddd, CLOCK=hh. mm. ss [, Q=(unitaddr[, F])] [, PROC=unitaddr] [, AUTO=characters]

DATE=yy.ddd

specifies the date in the following format:

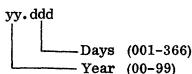
**CLOCK=hh. mm. ss**

specifies the time of day in the following format:

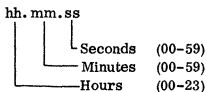

If the new clock setting implies a change of date, the new date must be explicitly stated using the DATE parameter.

Q=(unitaddr[, F])

specifies the name of the direct-access device on which the volume containing the input work queue (SYS1. SYSJOBQE) is to reside (do not specify a 2321 data cell in this operand). Space on this volume for the input work queue must have already been allocated. The F is a request to the system to format the job queue data set prior to the first job initiation; it must be used during the first IPL, but need not be used at subsequent IPLs.

PROC=unitaddr

specifies the name of the direct-access device on which the volume that contains the procedure library resides. If this parameter is not given, the system assumes that the procedure library is on the system residence volume.



AUTO=Characters

specifies, in systems with automatic START commands, whether you wish to retain any of those commands. For each automatic command printed out by the system, follow the equals sign by a Y if you want to retain the command, or by an N if you want to override the command.

START -- Start System Process

Operation	Operand
{ START } { S }	procname [. identifier] [, devicename] [, volumeserial] [, parmvalue] [, keyword=option, . . .] [, H= { 0 }] { 1 }

procname

specifies the name of the procedure to be started. This name can be either a standard name or a special one provided by your system programmer. Standard procnames include RDR for an input reader and WTR for an output writer.

IBM Assigned Names and the Processes They Describe

- CRJE Conversational Remote Job Entry
- BRDR Input reader for time-sharing option background jobs
- DSO Direct System Output Processing
- GFX Graphic Job Processor or Satellite Graphic Job Processor
- INIT Initiator
- RDR Input Reader (SYSIN data sets unblocked)
- RDR400 Input Reader (SYSIN data sets in 400-byte blocks)
- RDR3200 Input Reader (SYSIN data sets in 3200-byte blocks)
- RDRA Input Reader with ASB (SYSIN data sets in 3200-byte blocks)
- RJE Remote Job Entry Subsystem
- WTR Output Writer

H=0 or 1

In systems that have been generated with hierarchy support, system tasks (like a reader or writer) can be started in storage hierarchy 0 (H=0) or hierarchy 1 (H=1). If the H parameter is omitted, hierarchy 0 is assumed.

EXAMPLE: s rdr,00c,H=0
 s wtr,00e,H=1

identifier

the identifier identifies a reader or writer, when multiple readers or writers are started with the same procedure, if either the device name is not specified or it is the same for more than one task, e.g., disk reader.

devicename

specifies the name of an input or output device. This can be either a unit name (such as 280) or a general name (such as 2400). If specified, the name will override any corresponding unit specification in the catalogued procedure.

volumeserial

specifies the six-character serial number of a magnetic tape or direct-access volume. If specified, this parameter will override any corresponding volume serial specification in the cataloged procedure.



parmvalue

specifies parameter values to be passed to the program receiving control as a result of the START command. If more than one value is specified, parmvalue must be enclosed in parentheses, with commas separating the values. If one value is specified, no parentheses are needed. If parmvalue contains any non-alphanumeric character, such as an equals sign, parmvalue must be enclosed in parentheses.

keyword=option

specifies any appropriate keyword syntax allowable on a DD statement.

STOP -- Stop Process or Continual Display

Operation	Operand
{ STOP } { P }	{ [procname.]identifier } INIT. Pn JOBNAMES DSNAME SPACE STATUS

procname

the name of a process to be stopped (e.g., a RDR, WTR, or a job).

identifier

the identifier of the process as defined by the START command or the name of a job from the system input stream.

INIT. Pn

the initiator to be stopped, where n is the partition number in which the initiator is running.

JOBNAMES

a continual display of the names of jobs, initiated by the JOBNAMES parameter of the MONITOR command, is to be ended.

DSNAME

the system is to stop the continual display of the names of non-temporary data sets, as initiated by the DSNAME parameter of the MONITOR command.

SPACE

the system is to stop the continual display, in demount message, of the available space on a direct access volume. The display was initiated by the SPACE parameter of the MONITOR command.

STATUS

the system is to stop the continual display, at step end and job end, of the names and volume serial numbers of data sets with dispositions of KEEP, CATLG, and UNCATLG. The display was initiated by the STATUS parameter of the MONITOR command.

SWAP -- SWAP Volumes for Dynamic Device Reconfiguration (DDR)

Operation	Operand
{ SWAP } { G }	{ OFF } { ON } { xxx, yyy }

OFF

system-initiated Dynamic Device Reconfiguration is stopped and all permanent errors will bypass DDR processing.

ON

activates system-initiated Dynamic Device Reconfiguration.

xxx

the primary channel unit address of the device "from" which a volume is to be swapped.

yyy

the primary channel unit address of the device "to" which a volume is to be swapped.

NOTE: The devices specified by xxx and yyy must be of the same device type. xxx and yyy may specify the same device to permit maintenance of a particular volume or device.

UNLOAD -- Prepare Volume for Dismounting

(See Unload for PCP Commands.)

VARY -- VARY Status of Device or VARY Status of a Path

Operation	Operand
{ VARY } { V }	{ ALL } { (unitaddr[, unitaddr] . . .) } { , ONLINE } { , OFFLINE } { , ONGFX } { , OFFGFX [, { F }] } { , PATH, xxx, { ONLINE } } { , OFFLINE } }

ALL

for GFX, all units named for GJP or SGJP during system generation be made available (ONGFX) or unavailable (OFFGFX) for graphic job control operations.

unitaddr

the unit address of the input/output device whose status is to be changed.

ONLINE

the input/output devices identified in this command are to be made available for allocation by the job scheduler to problem programs.

OFFLINE

specifies that the input/output devices identified in this command are to be removed from the recognition of the job scheduler.

ONGFX



for GFX, the 2250s and/or telecommunication lines identified in this command are to be made available for graphic operations.

NOTE: This command does not vary the device online. To do this, use the VARY ONLINE command.

OFFGFX

for GFX, the 2250s and/or telecommunication lines identified in this command are to be made unavailable for graphic operations.

NOTE: This command does not vary the device offline. To do this, use the VARY OFFLINE command.

F

(used with OFFGFX) the operating system jobs being processed for the specified 2250s and/or 1130/2250 subsystems are to be ended immediately without notifying the users that this ending has occurred (F = fast stop). A printed record of previous job control operations cannot be obtained. The operator should notify the user at the 1130/2250 subsystem.

M

(used with OFFGFX) the operating system jobs being processed for the specified 2250s and/or 1130/2250 subsystems are to be ended immediately and the users requested to logoff (M = medium stop). A printed record of previous control operations can be obtained.

S

(used with OFFGFX) the operating system jobs currently being defined for or processed for the specified 2250s and/or 1130/2250 subsystems are to be allowed to reach normal or abnormal end before the users are requested to logoff (S = slow stop). A printed record of previous job control operations can be obtained. The operand is underscored to indicate that the system assumes S if none of the parameters F, M, and S has been specified.

PATH

this is a VARY PATH request (to be used only if Alternate Path Retry was specified at System Generation Time).

xxx

the channel unit address of the path to be varied.

ONLINE

the specified path is to be logically added to the system and is made available for allocation by the job scheduler to problem programs.

OFFLINE

the specified path is to be logically removed from the system.





WRITELOG -- Write Out System

Operation	Operand
{WRITELOG} W }	{classname} {CLOSE }

classname

specifies the name of the system output class with which the contents of the system log are to be associated.

CLOSE

specifies that the status of the system log is to be preserved. This operand must be used before stopping the system or data will be lost.

OS SVC'S

NAME	TYPE	HEX	GRP	NOTES
EXCP	1	00	IO	EXEC. CHAN. PROG
WAIT	1	01	SV	WAIT ON AN EVENT
WAITR	1	01	SV	WAIT; GIVE CNTRL TO LOWER PRIORITY TASK
POST	1	02	SV	POST AN ECB
EXIT	1	03	SV	EXIT
GETMAIN	1	04	SV	GET MAIN STORAGE
FREEMAIN	1	05	SV	FREE MAIN STORAGE
LINK	2	06	SV	LINK
XCTL	2	07	SV	TRANSFER CONTROL
LOAD	2	08	SV	LOAD
DELETE	1	09	SV	DELETE A LOADED PROG
REGMAIN	1	0A	SV	GET/FREEMAIN
TIME	1(3)	0B	SV	GET DATE/TIME OF DAY
SYNCH	2	0C	SV	SYNCHRONOUS EXIT
ABEND	4	0D	SV	ABNORMAL END
SPIE	3(1)	0E	SV	SET PROG INT ELEM.
ERREXCP	1	0F	IO	(ERROR) EXCP
PURGE	3	10	IO	REMOVE RQE'S FROM Q'S
RESTORE	3	11	IO	RESTORE RQE'S TO Q'S
BLDL	2	12	DM	GET FROM B DAM DRCTRY
FIND	2	12	DM	UPDATE BPAM DCB'S
OPEN	4	13	DM	OPEN DATA SET
CLOSE	4	14	DM	CLOSE DATA SET
STOW	3	15	DM	STORE INTO BPAM DIRECTORY
OPEN J	4	16	DM	OPEN, TYPE=J DATA SET
TCLOSE	4	17	DM	TEMP. CLOSE DATA SET
DEVTYPE	3	18	IO	FIND DCB DEVICE TYPE
TRBL	3	19	DM	DETM SPACE-BSAM WR RTM
CATALOG	4	1A	DM	CATALOG/UNCATALOG
INDEX	4	1A	DM	BLD/DELETE INDEX
LOCATE	3	1A	DM	GET VOL INFO ON CAT. DS
OBTAIN	3	1B	DM	READ DSCB'S
CVOL	4	1C	DM	OPEN & FORMAT CNTRL VOL
SCRATCH	4	1D	DM	SCRATCH DS ON DASD
RENAME	4	1E	DM	CHANGE DS NAME ON DASD
FEOV	4	1F	DM	FORCE EOVS
ALLOC	4	20	DM	ALLOCATE ON DASD
IOHALT	3	21	IO	HALT A DEVICE ACTIVITY
MGCR	4	22	JS	MAST. SCHD. GET
WTO	3	23	JS	WRITE TO OPERATOR
WTOR	3	23	JS	WRITE TO OPTR. W/REPLY
WTL	3	24	JS	WRITE TO LOG
SEGLD	2	25	SV	ASYNCH LOAD OF PGM SEG.
SEGWT	2	25	SV	SYNCH LOAD OF PGM SEG
TESTRAN	2	26	TT	ROUTE CNTRL & ACTION REQ
		27	UN	TEMP EXTEND OF IGC00031
EXTRACT	3(1)	28	SV	EXTRACT DATA FROM TCB
IDENTIFY	3	29	SV	NAME PGM FOR ATTACH
ATTACH	3(2)	2A	SV	ATTACH A TASK
CIRB	3(2)	2B	SV	EXIT EFFCTR. CREATE IRB

OS SVC'S (continued)

NAME	TYPE	HEX	GRP	NOTES
CHAP	1	2C	SV	CHANGE PRIORITY
OVLYBRCH	2	2D	SV	BR TO OVERLAN PROG
TIMER	1	2E	SV	TEST TIMER
STIMER	2	2F	SV	SET TIMER
DEQ	1	30	SV	REMOVE PGM FROM Q
TTOPEN	3	31	TT	INITIATE SUPV FACITY
CHAKPT	4	32	SV	TAKE CHECKPOINT NOT SUP
ABDUMP	4	33	SV	ABNORMAL; DUMP
RESTART	3	34	SV	REFRESH P. P. CORE
RELEX	3	35	DM	RELEASE FROM XCLUSIVE ST.
DISABLE	2	36	DM	RUN DISABLED
EOV	4	37	DM	END OF VOLUME
ENQ	1	38	SV	Q REQUESTOR
FREEDBUF	3	39	DM	RELEASE DYNM BUF AREA
REQBUF	1	3A	TP	REQUEST BTAM BUFFER
RELBUF	1	3A	TP	RELEASE BTAM BUFFER
SPAR	3	3B	GD	SPECIFY ATTN. RTN.
STAE	1	3C	SV	SPEC. TASK ABEND EXIT
TTSVAV	3	3D	TT	SAVE LOAD MOD. INFO
DETACH	1	3E	SV	DETACH A TASK
CHKPT		3F	UN	TAKE CHECKPOINT
RDJFCB	3	40	DM	READ JFCB FROM Q
QWAIT	2	41	TP	WAIT ON Q
DAR	3	42	GD	DELETE AN ATTN RTN
QPOST	2	43	TP	POST QUEUE
ARB	2	44	GD	ASSIGN/RELEASE BUF.
BSP	3	45	DM	BKSP PHYS BLOCK
GSERV	2	46	GD	SERVICE GRPHC ATTN
WAITATTN	2	47	GD	WAIT FOR GRPHC ATTN.

devicetype = actual device as:	X'ss'	Den-	Trans-	option	
	ss	sity	late	LOG	Log control statements on SYSLST
		Parity	Convert	DUMP	Dump registers and main storage on SYSLST if abnormal program end
				LINK	Write language translator output on SYSLNK for linkage editing
24007				DECK	Output object module on SYSPCH
2400T9				LIST	Output listing of source module on SYSLST
1442N1				LISTX	Output Procedure Division Map (COBOL) on SYSLST
2520B1	10	200	odd off on	SYM	Punch symbol table on SYSPCH (Assembler); output Data Division Map (COBOL) on SYSLST
2501	20	200	even off off	XREF	Output symbolic cross reference list (Assembler) on SYSLST
2540R	28	200	even on off	ERRS	Output listing of all errors in source program (COBOL/FORTRAN) on SYSLST
2540P	30	200	odd off off		To suppress any of the above options prefix operation with NO - e.g., LOG, NOLOG
2520B2	38	200	odd on off	48C	48-character set on SYSIPT for PL/I
2520B3	50	556	odd off on	60C	60-character set on SYSIPT for PL/I
1442N2	60	556	even off off	CATAL	Catalog program/phase in core image library after link editing
1403	68	556	even on off	STDLABEL	Cause all disk or tape labels to be written on the standard label track*
1403U	70	556	odd off off		
1404	78	556	odd on off	PARSTD	All standard labels for one partition
1443	90	800	odd off on		
1445	A0	800	even off off	USRLABEL	Cause all disk or tape labels to be written on the user label track*
1050A	A8	800	even on off	MINSYS	Minimal modules from Linkage Editor**
2671	B0	800	odd off off	GO	Cause linkage edited program on SYSLNK to be cataloged or executed. Use with CATAL option or EXEC statement**
UNSP	B8	800	odd on off		*DOS only
UNSPB	C0	800	single density 9-track		**TOS only
	C0	1600	dual density 9-track		
2311	C8	800	dual density 9-track		
2314					
2321					
2701					
2702					
2703					
7770					
7772					
2260					
1285					
1287					

The above values are for magnetic tape. If omitted X'CO' (9 track) or X'90' (7 track) is assumed. X'ss' designates the SADxxx requirement for a 2702 as follows:
 X'00' = SADO, X'01' = SAD1,
 X'02' = SAD2, X'03' = SAD3.
 X'00' is the default option. This information is not accepted on the ASSGN statement.

Job Ctrl.	Operator Commands				
	JC	AR	SPI/FI	IPL	
					<p>When accepted: <u>Job Ctrl.</u> (Job Control Statements) - Between Jobs and Job Steps. Affects Background Job only. Generally effective only for given job, whereas operator JC holds until next IPL. Precede operation with//b.</p> <p><u>JC</u> (Job Control) - Between Jobs and Job Steps. <u>AR</u> (ATTN Routine) - After Pressing request key on 1052. <u>FI</u> (Foreground Initiation) - After ATTN command START. <u>IPL</u> - During Initial Program Loading - TOS. <u>SPI</u> - Single Program Initiator - DOS.</p> <p>Label Information: The label statements for a tape file are TLBL (No VOL) or VOL followed by TPLAB The label statements for a DASD file are DLBL or VOL followed by DLAB followed by one EXTENT or XTENT for each area of the file in the volume All label statements must immediately precede the EXEC statement to which they apply</p>

X			Provide volume label information	VOL	SYSxxx, filename
X		X	Provide tape label information	TLBL	filename, ['file-ID'], [date], [file serial number], [volume sequence number], [file sequence number], [generation number], [version number]

filename: 1 to 7 characters identical to the DTF symbolic name for the file.

NOTE: The following operands are all optional. If any is omitted on input files, no checking is done. If omitted on output files, the default option is assumed.

file-ID: 1 to 17 alphameric characters (within apostrophes) indicating the name associated with the file.
Default:
The DTF filename is used.

date: 4 to 6 numeric characters in the format: yy/dd. Indicates expiration date for output files and creation date for input files. For output files, a 1-to-4-character retention period (d-dddd) may be specified.
Default:
A 0-day retention period is assumed.

Job Ctrl.	Operator Commands				When accepted: <u>Job Ctrl.</u> (Job Control Statements) - Between Jobs and Job Steps. Affects Background Job only. Generally effective only for given job, whereas operator JC holds until next IPL. Precede operation with//b.	<u>JC</u> (Job Control) - Between Jobs and Job Steps. <u>AR</u> (ATTN Routine) - After Pressing request key on T052. <u>EI</u> (Foreground Initiation) - After ATTN command START. <u>IPL</u> - During Initial Program Loading - TOS. <u>SPI</u> - Single Program Initiator - DOS.
	JC	AR	SPI/FI	IPL		
					Label Information: The label statements for a tape file are TLBL (No VOL) or VOL followed by TPLAB The label statements for a DASD file are DLBL or VOL followed by DLAB followed by one EXTENT or XTENT for each area of the file in the volume All label statements must immediately precede the EXEC statement to which they apply	
					file serial number: 1 to 6 numeric characters indicating the volume serial number of the first or only reel. This field is right-aligned and padded with zeros. Default: The volume serial number of the first file is assumed.	
					volume sequence number: 1 to 4 numeric characters in ascending order for each volume of a multiple volume file. Default: BCD 0001 is assumed.	
					file sequence number: 1 to 4 numeric characters in ascending order for each volume of a multiple file volume. Default: BCD 0001 is assumed.	
					generation number: 1 to 4 numeric characters used to modify the file-ID. Default: BCD 0001 is assumed.	

		Operator Commands				When accepted:	
		Job Ctrl.	JC	AR	SPI/FI	IPL	<u>Job Ctrl.</u> (Job Control Statements) - Between Jobs and Job Steps. Affects Background Job only. Generally effective only for given job, whereas operator JC holds until next IPL. Precede operation with//b. <u>JC</u> (Job Control) - Between Jobs and Job Steps. <u>AR</u> (ATTN Routine) - After Pressing request key on 1052. <u>FI</u> (Foreground Initiation) - After ATTN command START. <u>IPL</u> - During Initial Program Loading - TOS. <u>SPI</u> - Single Program Initiator - DOS.
						Label Information: The label statements for a tape file are TLBL (No VOL) or VOL followed by TPLAB The label statements for a DASD file are DLBL or VOL followed by DLAB followed by one EXTENT or XTENT for each area of the file in the volume All label statements must immediately precede the EXEC statement to which they apply	
X				X			version number: 1 or 2 numeric characters modifying the generation number. <u>Default:</u> BCD 01 is assumed.
	Provide tape file label information					TPLAB	{'label fields 3-10'} {'label fields 3-13'}
							fields 3-13: enter a continuous character string through column 71, continuation code (any character) in col. 72 and complete the string in a continuation statement beginning in column 16
X				X			'label fields 1-3', c xxxx, yyddd, yyddd, 'system code' [,type]
	Provide DASD file label information					DLAB	c = continuation code (any character) in col. 72; enter remaining parameters (xxxx etc.) on a continuation statement beginning in column 16 xxxx = volume sequence no. yyddd, yyddd = file creation date followed by file expiration date 'system code'. = 13 character string type = <u>SD</u> , DA, ISC, ISE

Job Ctrl.	Operator Commands				When accepted:
	JC	AR	SPI/FL	IPL	
					<p><u>Job Ctrl.</u> (Job Control Statements) - Between Jobs and Job Steps. Affects Background Job only. Generally effective only for given job, whereas operator JC holds until next IPL. Precede operation with//b.</p> <p><u>JC</u> (Job Control) - Between Jobs and Job Steps. <u>AR</u> (ATTN Routine) - After Pressing request key on 1052. <u>FI</u> (Foreground Initiation) - After ATTN command START. <u>IPL</u> - During Initial Program Loading - TOS. <u>SPI</u> - Single Program Initiator - DOS.</p>
					<p>Label Information: The label statements for a tape file are TLBL (No VOL) or VOL followed by TPLAB The label statements for a DASD file are DLBL or VOL followed by DLAB followed by one EXTENT or XTENT for each area of the file in the volume All label statements must immediately precede the EXEC statement to which they apply</p>
X			X		<p>DLBL filename, ['date file ID'], [date information], [codes]</p> <div style="border: 1px solid black; padding: 5px;"> <p>filename: 1 to 7 characters. The filename corresponding to the DTF table name.</p> <p>data file ID: 1 to 44 characters, within apostrophes. The name associated with the data set.</p> <p>date information: 1 to 6 characters. The retention period of the file or the absolute expiration date.</p> <p>codes: 2 or 3 characters indicating the file type [SD, DA, ISC, ISE].</p> </div>
X			X		<p>Indicate limits of a file on a DASD unit EXTENT</p> <p>[symbolic unit], [serial number], [type], [sequence number], [relative track], [number of tracks], [split cylinder track], [B = bins]</p> <div style="border: 1px solid black; padding: 5px;"> <p>bins: 1 or 2 characters. Not required for SD or ISFMS files. If omitted, bin zero is assumed for both parts.</p> <p>symbolic unit: symbolic unit of the volume in form SYSxxx.</p> <p>serial number: 1 to 6 characters. If omitted, the volume serial number of the preceding extent is used.</p> </div>

Operator Commands		Job Ctrl.			
JC	AR				
X					
	X				
<p>When accepted:</p> <p><u>Job Ctrl.</u> (Job Control Statements) - Between Jobs and Job Steps. Affects Background Job only. Generally effective only for given job, whereas operator JC holds until next IPL. Precede operation with //b.</p> <p><u>JC</u> (Job Control) - Between Jobs and Job Steps.</p> <p><u>AR</u> (ATTN Routine) - After Pressing request key on 1052.</p> <p><u>FI</u> (Foreground Initiation) - After ATTN command START.</p> <p><u>IPL</u> - During Initial Program Loading - TOS.</p> <p><u>SPI</u> - Single Program Initiator - DOS.</p>					
<p>Label Information: The label statements for a tape file are TLBL (No VOL) or VOL followed by TPLAB The label statements for a DASD file are DLBL or VOL followed by DLAB followed by one EXTENT or XTENT for each area of the file in the volume All label statements must immediately precede the EXEC statement to which they apply</p>					
<div style="border: 1px solid black; padding: 5px;"> <p>type: one character indicating file type [1, 2, 4, 8]</p> <p>sequence number: 1 to 3 characters. Not required for DA, DAM, or ISFMS.</p> <p>relative track: 1 to 5 characters. Not required for DA, SD, or ISFMS files.</p> <p>number of tracks: 1 to 5 characters. Not required for SD, DAM, or ISFMS files.</p> <p>split cylinder tracks: 1 or 2 numeric characters from 0-19. If omitted, extent type 8 is assumed.</p> </div>					
X			Indicate limits of a file on a DASD unit	XTENT	<div style="border: 1px solid black; padding: 5px;"> <p>type, sequence, lower, upper, 'serial no', SYSxxx [,B₂]</p> <p>type = 1 for data area (no split cylinders) 2 for overflow area (for indexed sequential file) 4 for index area (for indexed sequential file) 128 for data area (split cylinder)</p> <p>sequence = 0-255 for sequence no. of extent within multi-extent files</p> <p>lower/upper = lower/upper extent in the form B₁C₁C₁C₂C₂C₂H₁H₂H₂</p> <p>B₂ = 0 for 2311, 0-9 for 2321; B₂ = B₁ if omitted.</p> </div>

Job Ctrl.	Operator Commands				When accepted: <u>Job Ctrl.</u> (Job Control Statements) - Between Jobs and Job Steps. Affects Background Job only. Generally effective only for given job, whereas operator JC holds until next IPL. Precede operation with//b.	JC (Job Control) - Between Jobs and Job Steps. <u>AR</u> (ATTN Routine) - After Pressing request key on 1052. <u>FI</u> (Foreground Initiation) - After ATTN command START. <u>IPL</u> - During Initial Program Loading - TOS. <u>SPI</u> - Single Program Initiator - DOS.
	JC	AR	SPI/FI	IPL		
				X	Add a device to PUB table	ADD X'cuu' [(k)], device type [,X'ss'] k = S (switchable) or 0-255 for priority designation (0=highest)
	X	X			Allocate foreground program areas	ALLOC { F1 = nK [,F2 = nK] } { F2 = nK [,F1 = nK] } n = an even integer in the range 0-510
	X				Assign symbolic names to I/O devices	ASSGN SYSxxx, { X'cuu' } { { X'ss' } } [,TEMP] { UA } { { ,ALT } }
	X		X		Assign symbolic names to I/O devices	ASSGN SYSxxx, { X'cuu' } { { X'ss' } } { UA } { { ,ALT } }
				X	Initiate batch processing in indicated partition	BATCH { blank, [BG], [F1], [F2] } (not for TOS) UA: not valid for foreground initiation

Job Ctrl.	Operator Commands					When accepted:
	JC	AR	SP/FI	IPL		
						<p><u>Job Ctrl.</u> (Job Control Statements) - Between Jobs and Job Steps. Affects Background Job only. Generally effective only for given job, whereas operator JC holds until next IPL. Precede operation with//b.</p> <p><u>JC</u> (Job Control) - Between Jobs and Job Steps. <u>AR</u> (ATTN Routine) - After Pressing request key on 1052. <u>FI</u> (Foreground Initiation) - After ATTN command START. <u>IPL</u> - During Initial Program Loading - TOS. <u>SPI</u> - Single Program Initiator - DOS.</p> <p>Label Information: The label statements for a tape file are TLBL (No VOL) or VOL followed by TPLAB The label statements for a DASD file are DLBL or VOL followed by DLAB followed by one EXTENT or XTENT for each area of the file in the volume All label statements must immediately precede the EXEC statement to which they apply</p>
		X				Cancel execution of current job in specified area CANCEL $\left\{ \begin{array}{l} \text{BG} \\ \text{F1} \\ \text{F2} \end{array} \right\}$
	X		X			Cancel execution of current background job or initiation of foreground job CANCEL blank
	X	X				Close a magnetic tape for DASD unit CLOSE SYSxxx $\left[\begin{array}{l} ,X'cuu' [,X'ss'] \\ ,UA \\ ,IGN \\ ,ALT \end{array} \right]$
	X					Enter date in communication region DATE $\left\{ \begin{array}{l} \text{mm/dd/yy} \\ \text{dd/mm/yy} \end{array} \right\}$
				X		Delete a device from PUB table DEL X'cuu'
	X					Make a device unavailable for system operations DVCDN X'cuu'

Operator Commands		Job Ctrl.				When accepted: <u>Job Ctrl.</u> (Job Control Statements) - Between Jobs and Job Steps. Affects Background Job only. Generally effective only for given job, whereas operator JC holds until next IPL. Precede operation with //b.	JC (Job Control) - Between Jobs and Job Steps. <u>AR</u> (ATTN Routine) - After Pressing request key on 1052. <u>FI</u> (Foreground Initiation) - After ATTN command START. <u>IPL</u> - During Initial Program Loading - TOS. <u>SPI</u> - Single Program Initiator - DOS.
		JC	AR	SPI/FI	IPL		
<p>Label Information: The label statements for a tape file are TLBL (No VOL) or VOL followed by TPLAB The label statements for a DASD file are DLBL or VOL followed by DLAB followed by one EXTENT or XTENT for each area of the file in the volume All label statements must immediately precede the EXEC statement to which they apply</p>							
X					Return a device to available status	DVCUP X'cuu'	
X					Terminate job control, load program and execute	EXEC [programe]	
			X		Terminate foreground initiation, load program and execute	EXEC programe	
X		X			Maintain I/O assignments for foreground area(s)	HOLD {F1 [,F2]} {F2 [,F1]}	
X					Indicate beginning of job control data	JOB jobname	
X		X			Reserve storage at link edit time for tape and <u>nonsequential</u> DASD file label processing	TAPE (nn) <u>for TOS</u> or {TAPE [(nn)]} {NSD (nn)} <u>for DOS</u>	
						TOS {TAPE (nn): nn = decimal no. of pairs of TLBL statements or VOL/TPLAB statements	

Job Ctrl.	Operator Commands				When accepted: <u>Job Ctrl.</u> (Job Control Statements) - Between Jobs and Job Steps. Affects Background Job only. Generally effective only for given job, whereas operator JC holds until next IPL. Precede operation with //b. Label Information: The label statements for a tape file are TLBL (No VOL) or VOL followed by TPLAB The label statements for a DASD file are DLBL or VOL followed by DLAB followed by one EXTENT or XTENT for each area of the file in the volume All label statements must immediately precede the EXEC statement to which they apply
	JC	AR	SPI/FI	IPL	
					<p> <u>JC</u> (Job Control) - Between Jobs and Job Steps. <u>AR</u> (ATTN Routine) - After Pressing request key on 1052. <u>FI</u> (Foreground Initiation) - After ATTN command START. <u>IPL</u> - During Initial Program Loading - TOS. <u>SPI</u> - Single Program Initiator - DOS. </p>
					<p> DOS { <ul style="list-style-type: none"> TAPE(nn): nn ignored; use statement only if tape file label processing and no nonsequential DASD file processing NSD(nn): nn = largest number of extents per single file; use statement if any nonsequential DASD file processing </p>
X	X				<p> Print list of I/O assignments LISTIO $\left. \begin{array}{l} \text{SYS} \\ \text{PROG} \\ \text{F1} \\ \text{F2} \\ \text{ALL} \\ \text{SYSxxx} \\ \text{UNITS} \\ \text{DOWN} \\ \text{UA} \\ \text{X 'cuu'} \end{array} \right\}$ </p>
			X		<p> Print list of I/O assignments $\left. \begin{array}{l} \text{BG} \\ \text{F1} \\ \text{F2} \\ \text{UA} \\ \text{ALL} \end{array} \right\}$ </p>

Job Ctrl.	Operator Commands				When accepted: <u>Job Ctrl.</u> (Job Control Statements) - Between Jobs and Job Steps. Affects Background Job only. Generally effective only for given job, whereas operator JC holds until next IPL. Precede operation with//b.	JC (Job Control) - Between Jobs and Job Steps. AR (ATTN Routine) - After Pressing request key on 1052. FI (Foreground Initiation) - After ATTN command START. IPL - During Initial Program Loading - TOS SPI - Single Program Initiator - DOS.
	JC	AR	SPI/FI	IPL		
					Label Information: The label statements for a tape file are TLBL (No VOL) or VOL followed by TPLAB The label statements for a DASD file are DLBL or VOL followed by DLAB followed by one EXTENT or XTENT for each area of the file in the volume All label statements must immediately precede the EXEC statement to which they apply	
	X	X	X		Log Job Control Statements and foreground initiation commands on SYSLOG	LOG blank
	X	X	X		Print map of main storage areas	MAP blank
	X	X			Hardware instruction retry (MOD-155)	MODE $\left\{ \begin{array}{l} R \\ STATUS \\ HIR \\ ECC \end{array} \right\} \left[\begin{array}{l} ,R \\ ,Q \end{array} \right] \left[\begin{array}{l} ,E=eeee \\ ,T=tttt \\ ,E=eeee,T=tttt \\ ,T=tttt,E=eeee \end{array} \right] \left\{ \right\}$
						R - Set recording mode for HIR and ECC. STATUS - Requests a report showing the current mode setting and EFL for HIR and ECC as well as the number of high speed buffer pages not being used. This report has the form: HIR, $\left\{ \begin{array}{l} R \\ Q \end{array} \right\}$,aaaa/bbbb,cccc/dddd ECC, $\left\{ \begin{array}{l} R \\ Q \end{array} \right\}$,aaaa/bbbb,cccc/dddd

Operator Commands		When accepted: <u>Job Ctrl.</u> (Job Control Statements) - Between Jobs and Job Steps. Affects Background Job only. Generally effective only for given job, whereas operator JC holds until next IPL. Precede operation with //b.	JC (Job Control) - Between Jobs and Job Steps. AR (ATTN Routine) - After Pressing request key on 1052. FI (Foreground Initiation) - After ATTN command START. IPL - During Initial Program Loading - TOS. SPI - Single Program Initiator - DOS.
Job Ctrl.	Label Information: The label statements for a tape file are TLBL (No VOL) or VOL followed by TPLAB The label statements for a DASD file are DLBL or VOL followed by DLAB followed by one EXTENT or XTENT for each area of the file in the volume All label statements must immediately precede the EXEC statement to which they apply		
JC			
AR			
SPI/FI			
IPL			

BUF DLT=nnn

aaaa=Current error count.

bbbb=Error count limit.

cccc=Current elapsed time.

dddd=Time limit.

nnn=The number of high speed (C40) buffer pages deleted since IPL.

HIR,R - Set recording mode for HIR.

HIR,Q - Set quiet mode for HIR.

ECC,R - Set recording mode for ECC.

ECC,Q - Set quiet mode for ECC.

E=eeee - Set the error limit from 8 to 9999 (the default is 8 errors in the specified time limit).

T=tttt - Set the time limit for error occurrences from 8 to 9999 (the default is an 8 hour time period for the specified number of errors).

Job Ctrl.	Operator Commands					When accepted: <u>Job Ctrl.</u> (Job Control Statements) - Between Jobs and Job Steps. Affects Background Job only. Generally effective only for given job, whereas operator JC holds until next IPL. Precede operation with //b.	JC (Job Control) - Between Jobs and Job Steps. <u>AR</u> (ATTN Routine) - After Pressing request key on 1052. <u>FI</u> (Foreground Initiation) - After ATTN command START. <u>IPL</u> - During Initial Program Loading - TOS. <u>SPI</u> - Single Program Initiator - DOS.
	JC	AR	SPI/FI	IPL			
					Label Information: The label statements for a tape file are TLBL (No VOL) or VOL followed by TPLAB The label statements for a DASD file are DLBL or VOL followed by DLAB followed by one EXTENT or XTENT for each area of the file in the volume All label statements must immediately precede the EXEC statement to which they apply		
		X	X		Transfer control to foreground program message routine	MSG {F1} {F2}	
X	X				Control magnetic tape operations	MTC opcode, {X'cuu'} {,nn} opcode = BSF, BSR, ERG, FSF, FSR, REW, RUN or WTM X'cuu': not valid for programmer Job Control nn = number of times operation is to be performed (in decimal form)	
	X	X	X		Suppress logging of foreground initiation commands and Job Control Statements on SYSLOG	NOLOG blank	
X					Establish program options	OPTION option 1 [,option 2, . . .]	
X	X		X		Allow for operator intervention	PAUSE [comments]	
		X			Allow for operator intervention	PAUSE <u>BG</u> [,EOJ] (NOT FOR TOS) <u>FI</u> <u>F2</u>	

		Operator Commands				When accepted:		
		JC	AR	SPI/FI	IPL	<u>Job Ctrl.</u>	(Job Control Statements) - Between Jobs and Job Steps. Affects Background Job only. Generally effective only for given job, whereas operator JC holds until next IPL. Precede operation with //b.	JC (Job Control) - Between Jobs and Job Steps. AR (ATTN: Routine) - After Pressing request key on 1052. FI (Foreground Initiation) - After ATTN command START. IPL - During Initial Program Loading - TOS. SPI - Single Program Initiator - DOS.
Job Ctrl.		JC	AR	SPI/FI	IPL	Label Information: The label statements for a tape file are TLBL (No VOL) or VOL followed by TPLAB The label statements for a DASD file are DLBL or VOL followed by DLAB followed by one EXTENT or XTENT for each area of the file in the volume All label statements must immediately precede the EXEC statement to which they apply		
				X		Specify card reader for further foreground initiation commands	READ	X'cuu'
	X		X			Unassign I/O units for foreground area(s) at end of job for area	RELSE	{ F1 [,F2] } { F2 [,F1] }
	X	X				Reset I/O assignment	RESET	{ SYS PROG } { ALL SYSxxx }
	X					Record on demand	ROD	blank
	X					Provide ID and location of check-point records and initiate restart	RSTRT	SYSxxx, nnn [,filename]
						<div style="border: 1px solid black; padding: 5px;"> nnnn = checkpoint record identification filename = symbolic name if a 2311/2314 disk is the checkpoint file </div>		

Job Ctrl.	Operator Commands				
	JC	AR	SPI/FI	IPL	
					<p>When accepted:</p> <p><u>Job Ctrl.</u> (Job Control Statements) - Between Jobs and Job Steps. Affects Background Job only. Generally effective only for given job, whereas operator JC holds until next IPL. Precede operation with//b.</p> <p><u>JC</u> (Job Control) - Between Jobs and Job Steps.</p> <p><u>AR</u> (ATTN Routine) - After Pressing request key on 1052.</p> <p><u>FI</u> (Foreground Initiation) - After ATTN command START.</p> <p><u>IPL</u> - During Initial Program Loading - TOS.</p> <p><u>SPI</u> - Single Program Initiator - DOS.</p>
					<p>Label Information: The label statements for a tape file are TLBL (No VOL) or VOL followed by TPLAB</p> <p>The label statements for a DASD file are DLBL or VOL followed by DLAB followed by one EXTENT or XTENT for each area of the file in the volume</p> <p>All label statements must immediately precede the EXEC statement to which they apply</p>
			X		<p>Initialize date and time</p> <p>SET DATE = {mm/dd/yy} [,CLOCK = hh/mm/ss]</p>
	X				<p>Initialize date, clock, UPSI, etc.</p> <p>SET [DATE = {mm/dd/yy}] [,CLOCK = hh/mm/ss] [,UPSI = nnnnnnn]</p> <p>[,LINECT = n1], [,RCLST = n2] [,RCPCH = n3] [,RF = YES,NO,CREATE]</p> <div style="border: 1px solid black; padding: 5px;"> <p>n = 0, 1, or X (unchanged)</p> <p>n1 = standard number of lines for output on each page of SYSLST</p> <p>n2 = decimal number indicating minimum number of SYSLST disk records remaining to be written before operator warning</p> <p>n3 = decimal number indicating minimum number of SYSPCH disk records remaining to be written before operator warning</p> </div>
		X			<p>Initiate program in specified area</p> <p>START { blank BG F1 F2 }</p>

Job Ctrl.	Operator Commands				When accepted: <u>Job Ctrl.</u> (Job Control Statements) - Between Jobs and Job Steps. Affects Background Job only. Generally effective only for given job, whereas operator JC holds until next IPL. Precede operation with//b.	JC (Job Control) - Between Jobs and Job Steps. AR (ATTN Routine) - After Pressing request key on 1052. FI (Foreground Initiation) - After ATTN command START. IPL - During Initial Program Loading - TOS. SPI - Single Program Initiator - DOS.
	JC	AR	SP/FI	IPL		
					Label Information: The label statements for a tape file are TLBL (No VOL) or VOL followed by TPLAB The label statements for a DASD file are DLBL or VOL followed by DLAB followed by one EXTENT or XTENT for each area of the file in the volume All label statements must immediately precede the EXEC statement to which they apply	
	X				Stop background program processing	STOP blank
		X	X		Give interval timer support to specified area	TIMER {BG}{F1}{F2}
	X		X		Load UCS buffer	UCS SYSxxx, phasename [,FOLD] [,BLOCK] [,NULMSG]
	X		X		Unassign I/O units for foreground area(s) immediately	UNA {F1 [,F2]}{F2 [,F1]}
X					Set user program switches	UPSI nnnnnnnn n = 0, 1 or X (unchanged)
	X				Terminate batch processing	UNBATCH blank (not for TOS)
X					Indicate end-of-data file input for a job step	/* ignored
X					Indicate end-of-job	/& ignored

	Operator Commands				
	Job Ctrl. JC	AR	SPI/FI	IPL	
					<p>When accepted: <u>Job Ctrl.</u> (Job Control Statements) - Between Jobs and Job Steps. Affects Background Job only. Generally effective only for given job, whereas operator JC holds until next IPL. Precede operation with //b.</p> <p><u>JC</u> (Job Control) - Between Jobs and Job Steps. <u>AR</u> (ATTN Routine) - After Pressing request key on 1052. <u>FI</u> (Foreground Initiation) - After ATTN command START. <u>IPL</u> - During Initial Program Loading - TOS. <u>SPI</u> - Single Program Initiator - DOS.</p> <p>Label Information: The label statements for a tape file are TLBL (No VOL) or VOL followed by TPLAB The label statements for a DASD file are DLBL or VOL followed by DLAB followed by one EXTENT or XTENT for each area of the file in the volume All label statements must immediately precede the EXEC statement to which they apply</p>
X					<p>Provide programmer-to-operator comments * comments</p>
	X	X	X	X	<p>End-of-communication (B) blank</p> <p>(B) is alter code 5.</p>
	X	X	X	X	<p>Cancel 1052 response. (C) blank</p> <p>(C) is alter code 0.</p>

- IEHPROGM -- builds and maintains system control data.
- IEHMOVE -- moves or copies collections of data.
- IEHLIST -- lists system control data.
- IEHINITT -- writes volume labels onto magnetic tape.
- IEHIOSUP -- updates entries in the supervisor call library.
- IFCEREPO -- edits and lists error environment records.
- IFCDIP00 -- reinitializes the system data set SYS1.LOGREC.
- IEHDASDR -- initializes, dumps, and restores direct access volumes.
- IEHATLAS -- recovers usable data from a defective track, assigns an alternate track, and merges replacement data with the recovered data onto the alternate track.
- IFHSTATR -- selects, formats, and writes information from error statistics by volume records.

The user controls the operation of a system utility program through use of job control statements and utility control statements.

THE DATA SET UTILITY PROGRAMS

These programs are used to reorganize, change, or compare data at the data set level and/or at the record level. The following general functions are performed by the data set utility programs:

- IEBCOPY -- copies or merges partitioned data sets.
- IEBCGENER -- copies records from a sequential data set or converts a data set from sequential to partitioned organization.
- IEBCOMPR -- compares records in sequential or partitioned data sets.
- IEBPDPCH -- prints or punches records residing in a sequential or partitioned data set.
- IEBTCRIN -- reads input from a 2495 Tape Cartridge Reader, edits the data, and produces a sequential data set.
- IEBUGDTE -- performs source language modifications into sequential or partitioned data sets.
- IEBSAM -- places source data from an indexed sequential data set into a sequential data set suitable for subsequent reconstruction.
- IEDEDIT -- creates an output data set containing a selection of jobs or job steps.
- IEBUGDAT -- updates a symbolic library.
- IEBDG -- provides a pattern of test data to be used as a programming debugging aid.

The user controls the operation of a data set utility program through use of job control statements and utility control statements.

THE INDEPENDENT UTILITY PROGRAMS

These programs are used to prepare direct-access devices for system use and to ensure that any permanent hardware errors incurred on a direct-access device (i.e., defective tracks) do not seriously degrade the performance of that device. The following general functions are performed by the independent utility programs:

- IBCDASDI -- initializes and assigns alternate tracks to a direct-access volume.
- IBCDMPRS -- dumps and restores the data contents of a direct-access volume.
- IBCRCVRP -- recovers usable data from a defective track, assigns an alternate track, and merges replacement data with the recovered data onto the alternate track.

The user controls the operation of an independent utility program through use of utility control statements. Since the programs are independent of the operating system, job control statements are not required.

```
/*  
//SYSIN (DD statement for the data set containing utility statements)  
DD statements for device allocation  
//SYSPRINT (DD statement for the message output data set)  
//stepname EXEC PGM = progame  
//jobname (JOB statement)
```

O/S UTILITY CONTROL CARD EXAMPLES

1. Card to print

```
/*  
DATA CARDS  
//SYSUT1 DD * DATA  
//SYSUT2 DD SYSOUT = A, DCB = (RECFM = F, BLKSIZE = 80,  
LRECL = 80, PRTSP = 1)  
//SYSIN DD Dummy  
//SYSPRINT DD SYSOUT = A  
//STEP EXEC PGM=IEBGENER  
//CRDPRT JOB
```

Notes: Place a blank card in front of data cards to prevent overprinting of first card.

2. Card to tape

OS

```

/*
DATA CARDS
//SYSUT1 DD *
//SYSUT2 DD Unit = 2400, Label = (,NL), DCB = (RECFM = F,
LRECL = 80, BLKSIZE = 80)
//SYSIN DD Dummy
//SYSPRINT DD SYSOUT = A
//STEP EXEC PGM = IEBGENER
//CDTP JOB

```

Notes: Variations in tape unit or label information must be accounted for in sysUT2 card. Blocking may be specified by RECFM = FB or VB and increasing blksize to some multiple of LRECL.

3. System list

```

/*
LISTPDS VOL = 2311 = DL1B02,
DSNAME = SYS1. LINELIB
LISTPDS DSNAME = (SYS1. PROCLIB,
SYS1. SVCLIB)
LISTVTOC DUMP, VOL = 2311 = 111111
LISTVTOC DUMP
LISTCTLG
//SYSIN DD *
//DD3 DD VOLUME = REF = SYS1. LINKLIB, UNIT = 2311,
DISP = OLD
//DD2 DD UNIT = 2311, VOLUME = SER = 111111, DISP = OLD
//DD1 DD DSNAME = SYS1. SVCLIB, DISP = OLD
//SYSPRINT DD SYSOUT = A
//STEP EXEC PGM = IEHLIST
//LIST JOB

```

7



INITIALIZING AND ASSIGNING ALTERNATE TRACKS ON DIRECT-ACCESS VOLUMES

The IBCDASDI (DASDI) independent utility program performs two separate functions: it initializes direct-access volumes for use with the operating system, and assigns alternate tracks on nondrum, direct-access storage volumes. A single job can initialize one volume or assign alternates for specified tracks on one volume. DASDI jobs can be performed continuously by stacking complete sets of control statements.

INITIALIZING A DIRECT-ACCESS VOLUME

The first function of the DASDI program is to initialize a direct-access volume. A volume can be initialized with or without a surface analysis (i. e., a test for defective tracks); however, a surface analysis should be included when a volume is initialized for the first time.

Note: A 2321 volume is automatically initialized with a surface analysis.

Initialization With Surface Analysis: The DASDI program:

- Checks for tracks and have been previously designated as defective (flagged) and have had alternates assigned. The program automatically assigns alternates (disk devices only). This test must be suppressed when a disk recording surface is being initialized for the first time.
- Performs a surface analysis of each track and automatically assigns alternates, if necessary (non-drum storage volumes only). Tracks that are available for disposition as alternates are checked first.
- Writes a standard home address, a track descriptor record (record 0), and erases the remainder of each track.
- Writes IPL records on track 0 (records 1 and 2).
- Writes volume label on track 0 (record 3) and provides space for additional records, if requested.
- Constructs and writes a volume table of contents (VTOC).
- Writes IPL program, if requested, on track 0 (2301 or 2314) or track 1 (2303 or 2311).

The DASDI program requires the following function-defining statements to initialize direct-access volumes:

1. DADEF Statement
2. VLD Statement
3. VTOCD Statement
4. IPLTXT Statement (optional)
5. LASTCARD Statement (optional)

These statements must appear in this sequence.

Note: A DASDI job that initializes a 2321 data cell cannot follow a DASDI job that initializes a different device type unless the DASDI program is reloaded.

DADEF Statement

The DADEF statement defines the direct-access volume to be initialized.

Name	Operation	Operand	
[name]	DADEF	TODEV=xxxx TOADDR=cuu [IPL= YES] VOLID=serial VOLID=SCRATCH [BIN=d]	
		[FLAGTEST=NO] [PASSES=n]	2
		[BYPASS= YES]	3
Notes: Applicable to initialization with or without surface analysis. Applicable to initialization with surface analysis. Applicable to initialization without surface analysis.			

TODEV=xxxx

specifies the device type of the direct-access device.

TOADDR=cuu

specifies channel number (c) and unit number (uu) of the device.

IPL=YES

specifies that an IPL program is to be written on the volume. An IPL initialization program must be written on a device to be used for system residence.

If IPL is omitted, no IPL program is written.

VOLID=serial

specifies the volume serial number of the volume to be initialized.

If "serial" matches the volume serial number found on the volume to be initialized, the operation proceeds. If it does not match, the operator is notified.

VOLID=SCRATCH

specifies that no volume serial number check is to be made.

FLAGTEST=NO (applicable with surface analysis)

specifies that the program is not to check for previously flagged tracks before surface analysis is attempted on this device. (FLAGTEST=NO applies only to disk storage devices, and should be specified when the disk recording surface is initialized for the first time.)

Note: Since no check is ever made for previously flagged tracks on drum volumes or on 2321 volumes, FLAGTEST=NO is not coded when these devices are initialized.

PASSES=n (applicable with surface analysis)

specifies that the program's defective-track checking feature is to make n number of passes (from 1 to 255) per track.

If PASSES is omitted, one pass is made per track. The PASSES option is not applicable to 2321 volumes.

**BYPASS=YES**

specifies that the program's defective - track checking feature is to be bypassed.

If BYPASS is omitted, tracks will be checked and those found defective will automatically be assigned alternates. The BYPASS option is not applicable to the 2321 Data Cell Drive.

BIN=d

specifies a decimal bin number (0-9). This parameter is applicable only to the 2321 Data Cell Drive.

VLD Statement

The VLD statement contains information for constructing an initial volume label and allocating space for additional labels.

Name	Operation	Operand
[name]	VLD	NEWVOLID= serial VOLPASS= 1 VOLPASS= 0 [OWNERID= xxxxxxxxxxxx] [ADDLABEL= n]

NEWVOLID=serial

specifies a 1- to 6-character volume serial number.

VOLPASS=1

specifies that the volume security bit is to be set to 1.

VOLPASS=0

specifies that the volume security bit is to be set to 0.

If VOLPASS is omitted, the volume security bit will be set to 0.

OWNERID=xxxxxxxxxx

specifies a 1- to 10-character field that identifies the owner of the volume.

If OWNERID is omitted, no identification is given.

ADDLABEL=n

specifies a number between one and seven that indicates the total number of additional labels for which space is to be allocated.

If ADDLABEL is omitted, 0 is assumed.

VTOCD Statement

The VTOCD statement contains information for controlling the location of the volume table of contents.

Name	Operation	Operand
[name]	VTOCD	STRTADR= nnnnn EXTENT= nnnn

STRTADR=nnnnn

specifies the 1- to 5-byte track address, relative to the beginning of the volume, at which the volume table of contents is to begin. The VTOC cannot occupy track 00 or any alternate track.

EXTENT=nmm

specifies the length of the volume table of contents in tracks. The number of entries per track for each type of device is given below.



<u>Device</u>	<u>VTOC Entries/Track</u>
2301	63
2314	25
2302	22
2303	17
2311	16
2321	8

IPLTXT Statement

The IPLTXT statement separates utility control statements from IPL program text statements. It is required only when IPL text is included. The statement consists of the operation IPLTXT, followed with blanks.

When IPL text is included, the END statement must contain the operation END in columns 2 to 4.

LASTCARD Statement

The LASTCARD statement is required only when a DASDI job or a series of stacked DASDI jobs is followed by other statements on the control statement input device. It must follow the last END statement applying to a DASDI job. It consists of the operation LASTCARD, followed with blanks.

ASSIGNING AN ALTERNATE TRACK

The second function of the DASDI program is used to (1) test a track and, if necessary, to assign an alternate, or (2) to bypass testing, and automatically assign an alternate.

Assigning an Alternate (With Testing): An alternate track will be assigned for a track specified for testing and found defective. If the defective track has had an alternate previously assigned, a new alternate is assigned. If the defective track is an unassigned alternate, it is flagged to prevent its future use. The alternate track address is made known to the operator.

If a track is tested and found to be "not defective," no alternate is assigned. The operator is notified by a message.

Assigning an Alternate (Without Testing): The program's defective track checking feature can be bypassed, and an alternate track can be assigned for any track, whether it is defective or not. If the specified track is an alternate, a new alternate is assigned. If the specified track is an unassigned alternate, it is flagged to prevent its future use.

GETALT Statement

Any number of alternate tracks on a volume can be assigned in a single job by including one GETALT statement for each track.

Name	Operation	Operand
[name]	GETALT	TODEV=xxxx TOADDR=cuu TRACK=cccchhh VOLID=serial [FLAGTEST=NO] [PASSES=n] [BYPASS=YES] [BIN=d]





TODEV=xxxx

specifies the device type of the direct-access device.

TOADDR=cuu

specifies the channel number (c) and unit number (uu) of the direct-access device.

TRACK=cccchhh

specifies the address of the track for which an alternate is requested, where cccc is the cylinder number and hhhh is the head number.

VOLID=serial

specifies the volume serial number of the volume to which an alternate track is to be assigned. If "serial" matches the volume serial number found on this volume, the alternate track assignment proceeds. If it does not match, the operator is notified.

FLAGTEST=NO (used when testing prior to assigning an alternate)

specifies that the program will not check for a previously flagged track before a surface analysis is attempted on this track (disk storage devices only).

PASSES=n (used when testing prior to assigning an alternate)

specifies that the program's defective track checking feature is to make n number of passes (from 1 to 255) when performing a surface analysis on this track.

If PASSES is omitted, one pass will be made on this track.

BYPASS=YES

specifies that the program's defective track checking feature is to be bypassed.

If BYPASS is omitted, the program assigns an alternate only if it finds that the specified track is defective.

BIN=d

specifies a decimal bin number (0-9). This parameter is applicable only to the 2321 Data Cell Drive.

Note: A list of defective tracks is provided with new IBM Disk Storage volumes. This list should be referred to the first time the DASDI program is to be used. The GETALT function can then be included in the first DASDI job to assign an alternate track for each track on the list. Subsequent DASDI jobs will "remember" those defective tracks, unless the FLAGTEST=NO option is specified for those jobs.

IBCDASDI EXAMPLES

IBCDASDI example 1 illustrates the first initialization of a disk storage volume. A surface analysis is performed with the initialization.



Sample Coding Form		
INIT	JOB	'INITIALIZE 2311'
	MSG	TODEV=1403, TOADDR=00E
	DADEF	TODEV=2311, TOADDR=190, VOLID=SCRATCH, FLAGTEST=NO
	VLD	NEWVOLID=111111
	VTOCD	STRTADR=1, EXTENT=9
	END	

IBCDASDI Example 1. Initializing a disk storage volume with surface analysis.

IBCDASDI example 2 illustrates an initialization (other than the first) of a drum storage volume. No surface analysis is performed with the initialization.

Sample Coding Form		
INIT	JOB	'INITIALIZE 2301'
	MSG	TODEV=1403, TOADDR=00E
	DADEF	TODEV=2301, TOADDR=1C0, VOLID=SCRATCH, BYPASS=YES
	VLD	NEWVOLID=230100
	VTOCD	STRTADR=1, EXTENT=3
	END	

IBCDASDI Example 2. Initializing a drum storage volume without surface analysis.

Sample Coding Form			
INIT	JOB	'INITIALIZE 2311'	COMMENTS
	MSG	TODEV=1403, TOADDR=00E	MESSAGE OUTPUT
	DADEF	TODEV=2311, TOADDR=108, IPL=YES	VOLUME DEFINITION
	VLD	NEWVOLID=P1, OWNERID=BROWN,	VOLUME LABEL
		ADDLABEL=2	DEFINITION
	VTOCD	STRTADR=2, EXTENT= 8	VTOC DEFINITION
	IPLTXT		DELIMITER
			IPL PROGRAM
TXT			.
.	IPL PROGRAM		.
.			.
TXT			.
END			

IBCDASDI Example 3. Initializing a direct-access volume.



IBCDASDI Example 4 illustrates the assignment of three alternate tracks to a disk storage volume, without re-initialization of the volume. The program's defective-track checking feature is bypassed when the first two of the three tracks are assigned.

Sample Coding Form			
ALTRK	JOB	'ASSIGN ALTERNATE TRACKS ON 2311'	COMMENTS
	MSG	TODEV=2400, TOADDR=180	MESSAGE OUTPUT
STMT1	GETALT	TODEV=2311, TOADDR=190, TRACK=006F0001,	C
		BYPASS= YES, VOLID=P2	
STMT2	GETALT	TODEV=2311, TOADDR=190, TRACK=00910004,	C
		BYPASS= YES, VOLID=P2	
STMT3	GETALT	TODEV=2311, TOADDR=190, TRACK=004B0007,	C
		VOLID=P2	
	END		

IBCDASDI Example 4. Assigning Alternate Tracks on a Disk Storage Volume

DUMPING AND RESTORING A DIRECT-ACCESS VOLUME

The IBCDMPRS (DUMP/RESTORE) program dumps and restores the data on direct-access volumes. The data contents of a direct-access volume (all data except the home address) can be "dumped" onto IBM 2311 or 2314 disk storage volumes or onto magnetic tapes, and restored onto a direct-access volume that resides on the same type of device as the source volume. Both the source volume and the volume onto which data is to be restored must have been initialized to IBM System/360 Operating System specifications. This utility is useful for preparing transportable copies and backup copies of direct-access volume contents.

DUMP Statement

The DUMP statement is used to identify both the source volume whose contents are to be dumped and the receiving volume. The data contents of the entire source volume is dumped, including any data on alternate tracks. If both the source and receiving volumes reside on 2311 Disk Storage Drives or on 2314 Disk Storage Drives, the data on the receiving volume is an exact replica of the source data and need not be restored.

Name	Operation	Operand
[name]	DUMP	FROMDEV=xxxx FROMADDR=cuu TODEV=xxxx TOADDR=cuu [VOLID=serial=list] [MODE=mm] [BIN=d]

FROMDEV=xxxx

specifies the device type of the source device.

FROMADDR=cuu

specifies channel number (c) and unit number (uu) of the source device.

TODEV=xxxx

specifies the device type of the receiving device.

If the receiving device is a magnetic tape drive and no MODE parameter is specified, the data is written at the highest density supported by the device. (For 7-track tape, the default mode is 93.)

TOADDR=cuu

specifies the channel number (c) and unit number (uu) of the receiving device.

VOLID=serial,[serial] ...

specifies the volume serials of the receiving volumes onto which data is to be dumped. (VOLID is required when the receiving volume has been initialized to operating system specifications.)

If "serial" matches the volume serial number found on the receiving volume, the dump operation proceeds. If it does not match, the operator is notified.

IBCDMPRS -- Dumping and Restoring a Direct-Access Volume



If VOLID is not specified and the receiving volume contains a volume serial number, the operator is notified.

MODE=mm

specifies the bit density for data written onto the receiving magnetic tape volume. This parameter is applicable to 7-track tape drives and to 9-track tape drives with density selections of 800 and 1600 bits-per-inch. Valid 7-track modes are shown in Independent Utilities Table 1. (Only those modes which set converter on are accepted.)

For 9-track tape drives with density selections of 800 and 1600 bits-per-inch, the mode settings are:

MODE=CB for 800 bpi.
MODE=C3 for 1600 bpi.

If the receiving device is not a magnetic tape drive, the MODE parameter is ignored. If the receiving device is a tape drive but no mode is specified, the data is written at the highest density supported by the device.

BIN=d

specifies a decimal bin number (0-9). This parameter is applicable only to the 2321 Data Cell Drive.

Note: When dumping from direct-access to magnetic tape, "dump time" can be minimized by specifying different channel selections in the TOADDR=cuu and FROMADDR=cuu keywords. For example,

DUMP FROMDEV=2311, FROMADDR=190, TODEV=2400, TOADDR=282

VDRL Statement

The VDRL (volume dump/restore limits) statement is used to specify the upper and lower limits of a partial dump. If a track within these limits has had an alternate assigned to it, the data on the alternate track is included in the dump. When the VDRL statement is used, it must be preceded by a DUMP statement and must be followed by an END statement.

Name	Operation	Operand
[name]	VDRL	BEGIN= nnnnn [END= nnnnn]

BEGIN=nnnnn

specifies a 1- to 5-byte relative track address that identifies the first track to be dumped.

END=nnnnn

specifies the relative track address of the last track to be dumped. If only one track is to be dumped, this address is the same as the beginning address.

If END is omitted, the last track of the volume, excluding those tracks reserved as alternates, is assumed to be the upper limit.

RESTORE Statement



The RESTORE statement is used to identify both the source volume whose data contents are to be restored and the receiving volume.

Name	Operation	Operand
[name]	RESTORE	FROMDEV=xxxx FROMADDR=cuu TODEV=xxxx TOADDR=cuu VOLID=serial [MODE=mm] [BIN=d]

FROMDEV=xxxx
specifies the device type of the source device.

FROMADDR=cuu
specifies the channel number (c) and unit number (uu) of the source device.

TODEV=xxxx
specifies the device type of the receiving device. This device type must be the same as the device containing the volume originally dumped.

TOADDR=cuu
specifies the channel number (c) and unit number (uu) of the receiving device.

VOLID=serial
specifies the volume serial number of the receiving volume.

If "serial" matches the volume serial number found on the receiving volume, the restore operation proceeds. If it does not match, the operator is notified.

MODE=mm
specifies the bit density for data written onto the receiving magnetic tape volume. This parameter must match the mode specified when data was written onto the source volume. MODE should not be specified if the source or receiving volume is not a magnetic tape, or if MODE was not specified when data was written onto the source volume.

Valid 7-track modes are shown in Independent Utilities Table 1. (Only those modes which set converter on are accepted.) For 9-track tape drives with density selections of 800 and 1600 bits-per-inch, the mode settings are:

MODE=CB for 800 bpi.
MODE=C3 for 1600 bpi.

BIN=d
specifies a decimal bin number (0-9). This parameter is applicable only to the 2321 Data Cell Drive.

Note: When restoring from magnetic tape, "restore time" can be minimized by specifying different channel selections in the TOADDR=cuu and FROMADDR=cuu keywords. For example:

RESTORE FROMDEV=2400, FROMADDR=282, TODEV=cuu, TOADDR=190

IBCMPRS -- Dumping and Restoring a Direct-Access Volume



IBCDMPRS Examples

IBCDMPRS Example 1 illustrates the dumping of a direct-access volume onto a tape volume.

IBCDMPRS Example 2 illustrates the restoring of dumped data onto a direct-access volume.

Sample Coding Form			
DUMP	JOB	DUMP 2311 ONTO TAPE	COMMENTS
	MSG	TODEV= 1052, TOADDR= 103	MESSAGE OUTPUT
	DUMP	FROMDEV= 2311, FROMADDR= 203,	C
		TODEV= 2400, TOADDR= 120	
	END		

IBCDMPRS Example 1. Dumping a Direct-Access Volume

Sample Coding Form			
RESTORE	JOB	RESTORE 2311 FROM TAPE	
	MSG	TODEV= 1052, TOADDR= 10B	
	RESTORE	FROMDEV= 2400, FROMADDR= 120, TODEV= 2311,	C
		TOADDR= 202, VOLID= PZ	
	END		

IBCDMPRS Example 2. Restoring a Direct-Access Volume

SEREP

SEREP (System Environment Recording, Editing, and Printing) is a program distributed as part of the diagnostic package for each System/360 installation. The program, with its operating procedures, is available to the installation's IBM customer engineer. (Each System/360 model has a different version of the SEREP program. Operating procedures, however, are the same for all versions.)

SEREP provides a means of printing the system status information stored in main storage at the time of a machine malfunction. Malfunction information is produced as output on an online printing device. The SEREP printout indicates the environment of the error and the device involved.

The address of the I/O device printed on the SEREP report is compared with the valid device addresses available to the system. The printing of a valid address indicates that a machine malfunction has occurred. The printing of an invalid device address indicates that a programming error has occurred.

How to Use SEREP

When a message or PSW code indicates that you should run the SEREP program to print out malfunction information:

- Load the SEREP deck in the card reader.
- Set the LOAD UNIT switches to the address of the card reader.
- Press the LOAD button on the system control panel.
- Save the SEREP printout for later use by your customer engineer.
- After SEREP is completed, the system is restarted via the IPL procedure.

If you are repeatedly asked to run the SEREP program, call your customer engineer.

THE IFCEREPO PROGRAM (EREPO)

Program Applications



The IFCEREPO program edits and writes records that have been stored in the SYS1.LOGREC data set by error environment recording programs OBR, SDR, SER0, and SER1. The records contain environmental data (machine indicator contents, register contents, etc.) that was stored when an error occurred.

The program can process four types of environment records:

- Machine-check (CPU) records, produced and stored as a result of machine-check interruptions caused by malfunctions in the central processing unit.
- Channel-check (inboard) records, produced and stored as a result of input/output interruptions caused by specific channel failures.
- I/O device (outboard) records, produced and stored as a result of permanent device errors.
- Statistical data records, produced and stored to maintain a count of input/output device errors.

The program is used to:

- Edit and write selected records.
- Accumulate machine-check, channel inboard, or I/O outboard records and place them in a new or updated history data set.
- Summarize machine-check, channel inboard, or I/O outboard records contained in the SYS1.LOGREC data set or in a history data set.
- Process (edit and write, accumulate, and/or summarize) records produced on a different machine model.

```
-----  
|//JOBA      JOB  
|//          EXEC PGM=IFCEREPO  
|//SERLOG    DD  DSNAME=SYS 1. LOGREC,DISP= (OLD, KEEP)  
|//EREPT     DD  SYSOUT=A  
|  
-----
```

IFCEREPO Example 1.

The IFCEREPO Program

- Records that were written within a specific period of calendar time can be selected.
- I/O outboard or statistical data records related to a specific unit address or device type can be selected.
- Input records can remain uncleared after processing. (The program normally clears each selected record to hexadecimal zeros in the SYS1.LOGREC data set when processing of that record is complete. However, an option can be specified to prevent the clearing of selected records.)

The IBM System/360 operating system provides a set of programs which may be used to test the functioning of I/O units. These tests together with the on-line test executive program make up the on-line test system. The On-Line Test Executive Program (OLTEP) functions as an interface between operating System/360 and the unit tests and provides communication with the operator during the running of tests; it also schedules and controls the running of the tests. OLTEP operates much like other programs composing the operating system; it resides in SYS1.LINKLIB, is called with standard job control statements, and is under control of the operating system at all times. Figure 1 shows the relationship of OLTEP to the operating system.

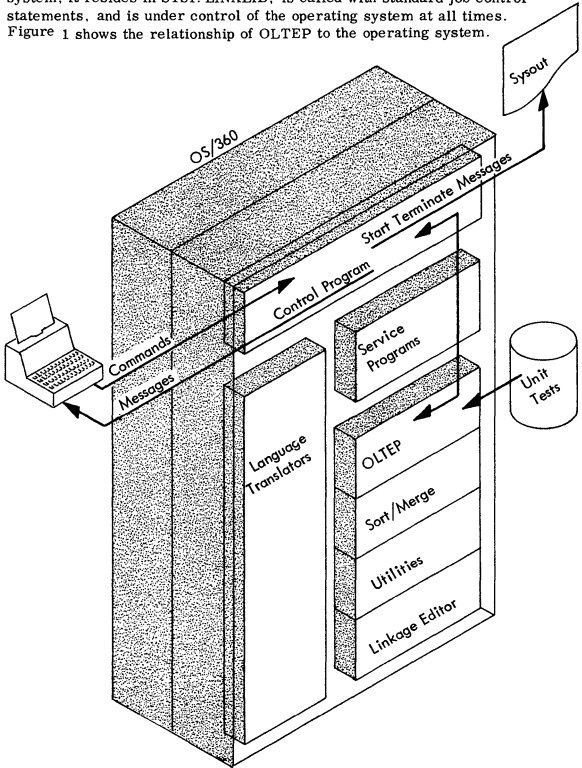

Figure 1. OLTEP as Part of the Operating System

An I/O unit may be tested using the on-line test system with minimum interference to the operation of other programs running in the system. Testing an I/O device ordinarily does not interfere with system input and output, although the unit being tested must be made unavailable for operating system use. After OLTEP is called, it notifies the operator that it is active and provides continuing communication with him during testing.

HOW TO ENVOKE OLTEP (2 ways)

- Enter JCL into the OS job stream.

OS

```
1//ONLNTST   JOB
2//JOBLIB    DD      DSN=OLTLIB, UNIT=2311, DISP=SHR,
                  VOL=SER=OLTVOL
3//          EXEC    PGM=IFDOLT
4//DIAGMSG   DD      SYSOUT=A
5//SERLOG    DD      DSN=SYS1.LOGREC, DISP=SHR
6//ACCIN     DD      PSN=HISTORY, DISP=SHR
7//INPUT     DD      UNIT=2540, DISP=OLD   (shaded area
8//SYSABEND  DD      SYSOUT=A              statements
9//CNTRLIN   DD      DATA                 are optional)
```

1. A job name in the name field and the word JOB in the operation field are the only requirements here. The account number and programmer's name parameters in the operand field may be required for certain systems; additional parameters are optional.
2. The JOBLIB statement is required to concatenate the private library (OLTLIB in this case) containing the unit tests with SYS1.LINKLIB. The UNIT parameter and the VOLUME parameter should indicate the direct access device and volume serial number on which the private library resides.
3. This statement identifies OLTEP as the program to be executed. (IFDOLT is the system name for OLTEP.) Additional parameters in the operand field of this statement are optional.
4. This DD statement defines the output device to be used by OLTEP for messages. The name DIAGMSG in the name field is a required name for this statement.
5. This statement refers to the SYS1.LOGREC data set on the system residence volume. Include this statement if you will run OLT programs that use SYS1.LOGREC for input.
6. This statement defines a history data set created by the IFCEREPO utility program. Include this statement if you will run OLT programs that use a history data set for input.
7. This statement defines a data set that contains test input data. Include this statement if you will run OLT programs that require data input.
8. This statement defines a data set in which an abnormal termination dump will be written.
9. This sequence defines a data set that contains OLTEP control statements. Include this sequence if you want to predefine some or all of the tests to be run.

- Enter the START command at the console.

In MFT

s oltep. Pn, options

In MVT

s oltep, options

s

Start command (MCS: Enter this command at the master console unless the maintenance console has been authorized to enter system control commands.)

oltep

name of OLTEP procedure in SYS1.PROCLIB.

.Pn

MFT only: number of the main storage partition to be used by OLTEP. Partition size must be at least 28K.

,options

any, all, or none of the following (in any order):

- jobstep=params -- enter this option if you want to specify job step parameters. (If you will test an IBM 1419, you must specify priority as described below.)

,input=params -- enter this option if you will run tests that require data input.

,history=params -- enter this option if you will run tests that require a history data set.

,serlog=params -- enter this option if you will run tests that require SYS1.LOGREC.

,outdata=params -- enter this option if you want test results printed before end-of-job.

,abdump=params -- enter this option if you want a dump in the event that the OLTEP job terminates abnormally.

HOW TO USE OLTEP

After the first-error communication interval is selected or rejected, the following message will be typed:

```
IFD105D ENTER DEV/TEST/OPT/
```

If the operator wishes to terminate OLTEP at this point, he may reply CANCEL. If he wishes to proceed with testing, he may issue a reply giving the device, test, and options he desires. These are described in the following sections.

CHOOSING THE DEVICE, TEST, AND OPTIONS

To choose the unit or units to be tested, the test or test to be used, and the options to apply, the operator must give a reply command which supplies information in three fields:

1. Device address field (DEV).
2. Test name field (TEST) which consists of test type and section. Routines within a section may be specified; they must be separated from the section name by a comma.
3. Option field (OPT).

Each of the three fields in the reply command must be followed by a slash. At the initial communication interval the reply command must include information in the device address and test fields; if options are not specified, default options will be supplied by OLTEP. Whether information is supplied in two or three fields, three slashes must be supplied.

If the first-error communication interval is chosen, when the first error occurs, the message:

```
IFD105D ENTER DEV/TEST/OPT/
```

will appear again, after a diagnostic message has been written on the SYSOUT device and after the message indicating where the first error occurred. To continue the same test on the same device with the same options, the operator need only key in three slashes. OLTEP then assumes that the fields remain unchanged since they were last supplied.

Entry	Devices Specified
181, 282-284/ 285-286, 184/	specifies devices 181, 282, 283, 284 specifies devices 285, 286, 184 specifies that testing of previously selected devices is to continue

Examples of Device Address Field Entries

Option	To Request Option	To Omit Option	Default
Print	PR	NPR	PR
Control Print	CP	NPR	CP
Error Print	EP	NEP	EP
First Error Communication	FE	NEP	FE
Parallel Print	PP	NPP	PP
Testing Loop	TL	NTL	NTL
Error Loop	EL	NEL	NEL
Manual Intervention	MI	NMI	NMI

- Print** Prints OLT program messages.
- Control Print** Print section start and terminate messages.
- Error Print** Print diagnostic messages from unit tests.
- First Error Communication** When OLT program detects a device error, OLTEP suspends testing and asks for a new Test Definition at the console. You can then define a new test, resume testing from the point at which the error occurred, or terminate the job step. If you choose to resume testing, you can change the OLTEP options that apply to the test.
- Parallel Print** OLTEP sends test output to the console as well as the //DIAGMSG data set.
- Testing Loop** Recycle a testing run currently specified. If testing loop is specified, there will be no communication interval on PCP systems, and the testing will be in an endless loop. To terminate the loop the operator must use the CANCEL command. To restart the job, job control statements to call OLTEP must be used. On MVT and MFT configurations a reply to message IFD104E may be used to terminate the loop.
- Error Loop** Loop as closely as possible on the section of code causing first error encountered. Remain in loop even if malfunction does not persist. No communication interval is possible when this option is stated, and again the CANCEL command (except on MVT and MFT configurations) must be used to terminate testing.

Manual Intervention

OLTEP executes OLT program routines that require manual intervention, such as changing the carriage control tape on a printer. OLTEP bypasses these routines except when you specify the MI option, or specify the routines by number in your Test Definition.

The operation of OLTEP is depicted on page 181. Testing may be stopped at any time during the procedure by issuing a CANCEL command or by issuing an EOT reply at one of the communication intervals. In addition to the messages shown in the diagram, there may be messages printed to indicate errors in operator responses.

When OLTEP receives control, the message:

IFD102I OLTS RUNNING

will appear on the console device and on the SYSOUT device. Then, if there are no OLTEP control statements to be processed, OLTEP sends you the message:

id IFD105D ENTER--DEV/TEST/OPT

This message asks you to define the first test; it will be repeated when the test is completed. The next message, in MFT and MVT, which OLTEP sends you is:

id IFD104E TO FORCE COMMUNICATION WITH OLTEP EXECUTIVE, ENTER ANY CHAR

This message permits you to interrupt testing. Do not reply immediately. Reply when and if you want to stop a test in order to define a new test or terminate the job step. If you do reply the IFD105D message will result.

To terminate the job step, reply to message IFD105D as follows:

r id, 'cancel'

If you need help in replying to message IFD105D reply to it as follows:

r id, 'prompt xxxx'

- xxxx = dev - devices
- test - tests
- opt - options
- all - all of the above

NOTE: For detailed instructions refer to Online Test Executive Program SRL (GC28-6650).

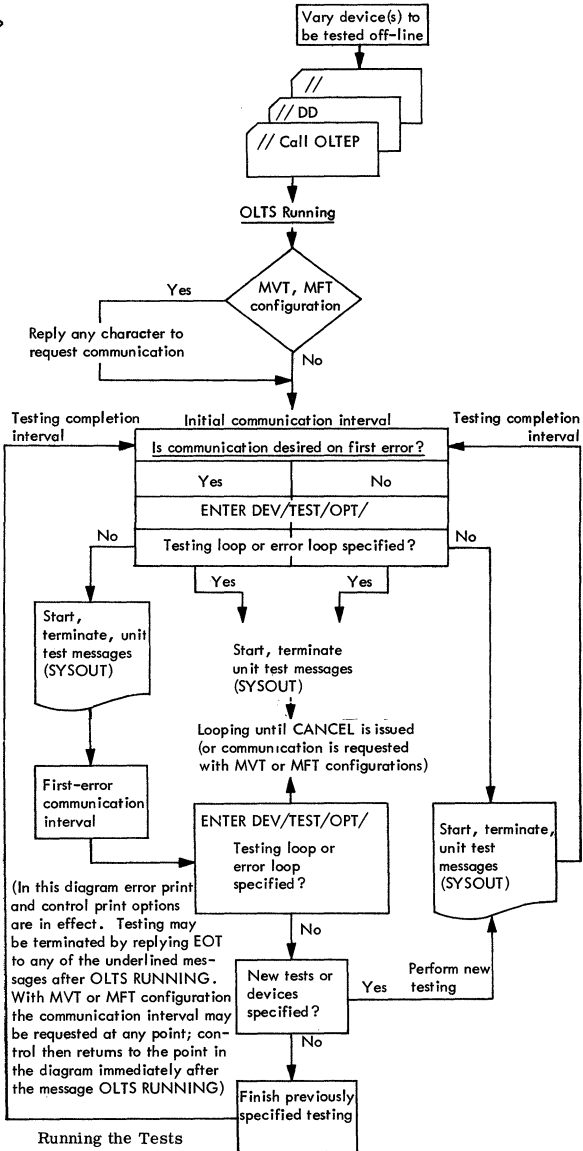

OLTEP FUNCTION

The IBM System/360 Disk Operating System provides a set of programs that can be used to test I/O units. These test programs and the On-Line Test Executive Program make up the On-Line Test System. The On-Line Test Executive Program (OLTEP) is an interface between the system and the test programs and communicates with the operator during the running of tests.

OLTEP operates much like other problem programs in the disk operating system. When OLTEP is called, it notifies the operator that it is active and communicates with him during testing. OLTEP can run in a batch-only system or as a background program in a multiprogram environment. It operates on 24K or larger systems under a DOS supervisor of 8K or larger.

You can test an I/O unit with minimum interference to other programs running on the system. Testing an I/O device ordinarily does not interfere with system input and output. Any unit being tested (except for direct access devices), must not be assigned to the foreground partitions. Direct access devices, however, may be shared.

During testing under control of OLTEP, the system error recovery procedures are bypassed for the device being tested. OLTEP has built-in data integrity safeguards so that no data is destroyed without operator permission and no protected data is accessed during testing.

ON-LINE TESTS (OLTS)

OLTs are called into main storage for execution by the scheduler portion of the OLTEP nucleus. Tests normally do not exceed 4K. However, those that do are loaded if the allotted background partition is large enough. If the partition is not large enough, OLTEP terminates.

For additional information on OLTs, refer to the IBM Maintenance Diagnostic Program OLTs documentation for the device to be tested.

Choosing the Devices

The device address field contains the physical address of the device to be tested. Either three or four digit device addresses are accepted by OLTEP. For example, you can enter device 181 as 181 or 0181. You must separate multiple entries in this field with commas, and you can use the hyphen to indicate inclusive devices. The field can accommodate up to 16 devices and is terminated by a slash. The figure shows examples of device selection.

Note: If an input device is required by the test section for Data Input Support or retrieval of environmental recording information, you must not enter that device in the device address field.

DEV Entry	DEVICE(s) Selected
0185/	185
0185-0187/	185, 186, and 187
0185,0187-0189/	185, 187, 188, and 189
0181,0282,0283/	181, 282, and 283
/	Use device(s) assigned in previous test. (Note)
NDR	No device required.
CH181	Perform a channel test on channel 1 using device 181. This must be a single entry.

Examples of Device Selection

Note: The device address must be reentered if the device was bypassed in the previous run.

When multiple teleprocessing lines for the 2702 and 2703 Transmission Control Units are entered initially, the first entry must represent line 0.

Choosing the Test

The test field specifies the test(s) to run on the selected device(s). The field is terminated by a slash (/), and is composed of the following subfields. Page 196 shows examples.

- Test Type (required). Specifies the type of I/O devices to test. You can specify only one type in a single Test-run-definition.

The test type must include a prefix of:

R = 2540 Reader test
P = 2540 Punch test
T = All
U = Test modules (OLTs only)

Note: If prefix is omitted, T is assumed. No other prefix is valid.

- Section (optional). Individual sections of the test are indicated by an alphabetic character(s) within the range A-Z. The maximum number of sections that can be run during any one test-run definition is 26. You must separate test section entries with a comma or hyphen (indicating inclusive sections). Multiple section entries are run in the sequence entered, duplicate entries cause a section to be repeated. An abnormal termination occurs if you specify a test section that cannot be found.

The section identification may be omitted only if there is 26 or more sections to the test. Sections A through Z are run. An abnormal termination occurs if you omit the test section identification and the test does not have sections A through Z.

- Routine (optional). OLTEP permits routine selection only when you specify a single test section. There is a maximum of 16 routine selections allowed, and they are specified by number. You can enter them in any sequence, but they will run in numeric order. You must separate these entries with a comma or hyphen. The routine numbers are found in the writeup that accompanies the OLT. Consult the OLT writeup to determine what test sections.

TEST ENTRY	TEST(s) Selected
2311/	Run all 2311 tests within the range A-Z. (Note 1)
2311A/	Run section A of test 2311.
2311A,C/	Run sections A and C of test 2311.
2311A-C,E,G/	Run sections A, B, C, E, and G of test 2311.
2311A,4/	Run routine 4 of section A, test 2311. (Note 2)
2311A,4-7,2/	Run routines 2, 4, 5, 6, and 7 of section A, test 2311. (Note 2)
P2540A,C/	Run sections A and C of test 2540.
/	Use the same test(s) as specified in the previous test.

Examples of Test Selection

Note 1: The section identification may be omitted only if there is 26 or more sections to the test. Sections A through Z are run.

Note 2: If a routine(s) is specified, only one section can be specified in that entry.

Choosing the Options

The option field identifies the options to use during the test run. Entries in this field are separated by commas. You can enter the options, with the exception of EXT=, in any order. The EXT=option, when used, must be the last entry. A default option is used in place of any omitted entry in the initial test-run definition. On succeeding test runs, omitted entries use the options selected in the previous run. The available options with their default values are shown below.

Option	Entry	Description
Testing Loop	TL (n) <u>N</u> TL	Recycle the test. If you specify a value (n), OLTEP runs the test the number of times indicated. If you do not specify a value, the test cycles 10 times. The maximum value allowed is 32,767 decimal. (Note 1)
Error Loop	EL (n) <u>N</u> EL	The test loops as near as possible to the part of the test causing the first error. If you specify a value (n), the test loops the number of times indicated. If you do not specify a value, the test loops the number of times indicated in the preface of the OLT. You can terminate the loop by specifying NEL following a request for communications. (Note 1)
Print	<u>P</u> R NPR	Print messages from the OLT. If you enter NPR, all messages are suppressed.
Error Print	<u>E</u> P NEP	Print diagnostic error messages from the OLT. The FE option overrides NEP when a first error is encountered.
Control Print	<u>C</u> P NCP	Print OLT start and termination messages on SYSLSST and SYSLOG.
Parallel Print	PP (n) <u>N</u> PP	Use the console device, in addition to SYSLSST for OLT messages. Four levels of print are available on the parallel printer by entering one of these numbers at (n). 0 HEADER only. 1 HEADER, DESCRIPTION, and COMMENTS. <u>2</u> HEADER and RESULTS. 3 HEADER, DESCRIPTION, COMMENTS and RESULTS.
First Error Communications	<u>F</u> E <u>N</u> FE	Forces a communications interval when the first error is encountered. A message is printed indicating the test being run and the device being tested. This is followed by the 01E105D message that allowed you to: <ul style="list-style-type: none">• Change the device and/or test fields.• Return to an exit point in the test by entering R 01, '///' or R 01, '/' (Option change)/.• Cancel the test by entering R 01, 'CANCEL'. There cannot be a first error communication if a console device isn't available.

Option	Entry	Description
Manual Intervention	MI <u>NMI</u>	Informs the OLT section to run all manual intervention routines within the test request.
EXT=	EXT=	Information following this option is passed to the OLT section by way of a 56-byte buffer. This information must be the last entry in the option field, and can contain any character but a slash. <u>EXAMPLE:</u> R 01, '181/2400C/TL, EXT=BLOCK4FFPRINT/' BLOCK4FFPRINT goes into a buffer area within OLTEP, and then passes on to the OLT section.

The default options are underlined.

Note 1: The FE option overrides the TL and EL options. However, if you enter R 01, '///' or R 01, '/(option change)/' at a first error communications interval, the TL and EL options, if specified, are in effect.

Prompting

A request for help made by the operator when entering the test-run definition. OLTEP prints examples of the field requested by the operator.

R id, 'PROMPT'

Quiesce Mode

The test section, through OLTEP, can request that all jobs in the foreground partition be temporarily stopped. If teleprocessing is not active on the system, OLTEP issues a message asking if the foreground partitions can be quiesced. If you reply R 04, 'NO', OLTEP bypasses the test section requesting quiesce mode. If you reply R 04, 'YES', OLTEP issues a message requesting that the foreground jobs be stopped. You should now give the operator commands to stop all jobs in the foreground partitions. OLTEP returns control to the test section after it ensures the foreground partitions are quiesced. If you reply R 04, 'YES', but do not quiesce the foreground partitions, OLTEP cannot continue. If teleprocessing is active on the system, the test section is bypassed.

You can find the procedure to quiesce the system in the writeup for message E2221.

DOS OLTEP Messages

The following messages, issued by OLTEP, appear on both the message output device (SYSLSST) and the console device (SYSLOG). The OLT messages are not listed here, but you can find them in the writeup that comes with the individual test. OLT data prints on the SYSLSST device only, unless you specify the parallel printer (PP) option.

The message format is:

BG rrEnnnt 'message text'

where

BG Appears only when OLTEP is running in a multi-programming environment. The BG indicates that the message pertains to the background partition in which OLTEP operates.

rr Is the reply code to use when responding to messages that require an immediate reply (D type). The codes are:

01 - For the 01E105D message.

04 - For all other OLTEP and OLT messages.

E Indicates that the Executive program (OLTEP) is issuing the message.

nnn Is the three-digit message number.

t Is the message type code where:

I Indicates an informational message that requires no reply.

D Indicates a decision message requiring an immediate reply.

An example of a reply is:

BG R 04, 'YES'

where BG is printed by the system if operating in a multi-programming environment, and R 04, 'YES' is entered by the operator.

Timing Test Programs

Timing test programs require the interval timer to make calculations. If the interval timer is not available on the system or is not operative, OLTEP issues a diagnostic message, and schedules another test. If a timing test is run in a multi-programming environment, the performance of any foreground program can be affected.

These restrictions apply to timing-test programs:

- You cannot perform timing tests on units attached to a multiplex channel (channel 0).
- You cannot perform timing tests when teleprocessing programs are operating within the system.

Diagnostic messages are printed if the timing test is attempted under these conditions, and you can then enter another test procedure.

Note: Timing test programs apply to System/360 Models 40 and larger. If you attempt a timing test on a Model 30, and test program issues a diagnostic message, and control returns to OLTEP. At this time, you can select another test or terminate OLTEP.

OPERATING PROCEDURES

Device Preparation

Certain device setup procedures are necessary before testing to insure protection and security of customer data. The following sections show the requirements for individual device types.

All devices must be in the Ready status with no manual intervention required.

Special Operating Considerations

Some OLTs require special operating considerations. These tests are identified by a pound sign (#) at the end of the OLT start and terminate messages.

EXAMPLE: S T2400A UNIT 0182 #
T T2400A UNIT 0182 #

The following apply only to these tests:

- A first error communications interval cannot occur if either the No Print (NPR) or No Error Print (NEP) options are specified.
- You may not specify a value with the EL option. If you enter the EL option, and an error occurs, the test loops on the error indefinitely. There are two ways to terminate the error loop:
 1. Force a communications interval with the Interrupt key. This is effective only if interrupts are permitted, and the error loop is large enough to sense for them.
 2. Cancel the background partition using the system commands.
- It is not recommended that both FE and EL be specified in the same test-run definition. The results are unpredictable, and depend on the OLT being run.

If you desire both options, select FE. When an error is encountered, you can enter R 01, '/NFE,EL/' at the first error communications interval. The test then loops on the error.

- Direct access volumes cannot be reformatted. If the test volume is not a CE volume, testing is restricted to file protect mode.
- The following messages cannot occur:

04E120D
E198I
E100I

S

EXAMPLE: BG E158I T XXXXXXXX UNIT YYYY (#)

*T

Cause: Execution of the test section (XX...X) started (S) or terminated (T) on unit YYYY. * indicates an error occurred while executing a test section. The pound sign (#), if present, indicates this is a special test. See Special Operating Considerations.

If the NCP option is in effect, this message does not appear.

Calling OLTEP

All Systems

The job control statements necessary for the execution of OLTEP are as follows:

STATEMENT	COMMENTS
// JOB XXXX	Mandatory.
// ASSGN SYSnnn, X'cuu'	One ASSIGN statement is necessary for each device tested or accessed by a test. None is required if the device was previously assigned.
// EXEC IJZADCLT	Mandatory.
// UPSI 01	This statement is necessary if a console device is available but the test-run definition is to be entered via the input job stream. Only one test-run-definition card is accepted, and any further communication is with the console.
dev/test/opt/	This statement is included if the test-run definition is entered via the input job stream. Only one statement is allowed.
/*	Mandatory.
/&	Mandatory.

Job Control Statements.

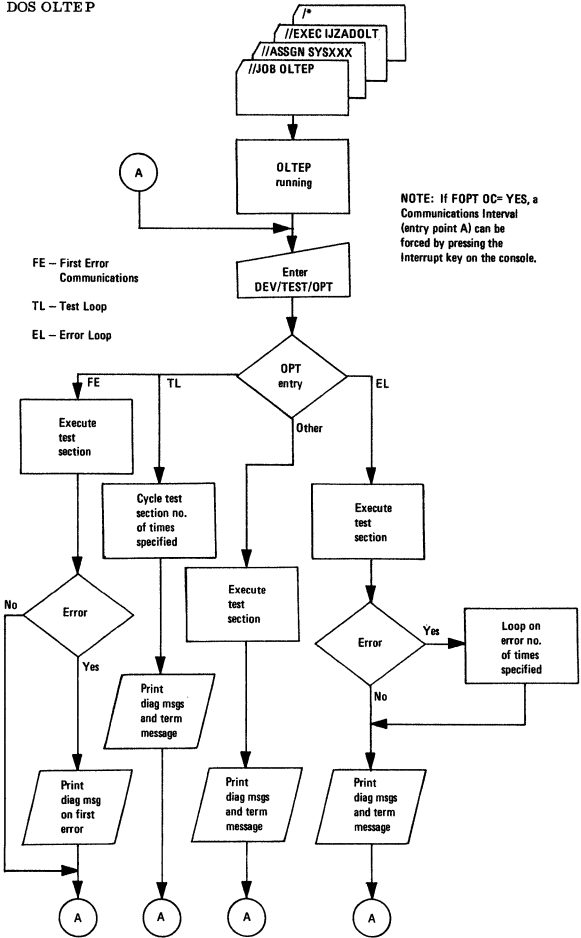

Running Test Sections without a 1052.
(Error Print and Control Print options in effect.)

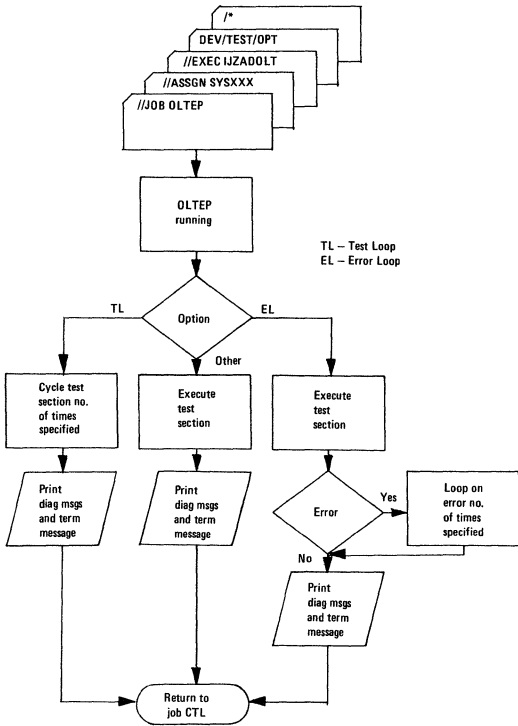

Running Test Sections without a 1052.
 (Error Print and Control Print options in effect.)



Example of OLTEP Operation.

BG assgn sys001,x'181'

BG assgn sys002,x'182'

BG // exec ijzadolt

OLTEP is loaded into the background partition.

BG E102I OLTS RUNNING

BG 01E105D ENTER -- DEV/TEST/OPT/

Initial communications interval.

BG r 01,'181/2400A//'

BG E107I OPTIONS ARE NTL,NEL,NPP,FE,NMI,EP,CP,PP.

BG E119I NON-STANDARD TAPE LABEL 0181

OLTEP finds a non-standard labeled tape mounted on the test device.

BG 04E139D REPLY B TO BYPASS, R TO RETRY, P TO PROCEED (MAY DESTROY DATA)

BG r 04,'p'

BG E158I S T2400A UNIT 0181

Error encountered.

BG E129I FIRST ERROR COMMUNICATION T2400A 001 UNIT 0181

BG 01E105D ENTER -- DEV/TEST/OPT/

First error communications interval.

BG r 01,'182//nfe,tl(2)/'

BG E107I OPTIONS ARE TL,NEL,NPP,NFE,NMI,EP,CP,PR

BG E158I S T2400A UNIT 0182

BG E158I T T2400A UNIT 0182

Console Interrupt Addresses.

BG E158I S T2400A UNIT 0182

BG 01E105D ENTER -- DEV/TEST/OPT/

Interrupt communications interval.

BG r 01,'/2400c,e/ntl/'

BG E107I OPTIONS ARE NTL,NEL,NPP,NFE,NMI,EP,CP,PR

BG E158I S T2400C UNIT 0182

BG E158I T T2400C UNIT 0182

BG E158I S T2400E UNIT 0182

BG E158I T T2400E UNIT 0182

BG 01E105D ENTER -- DEV/TEST/OPT/

BG r 01,'cancel'

Test completion communications interval.

BG 1100A READY FOR COMMUNICATIONS

BIBLIOGRAPHY

PUBLICATIONS SELECTOR CHARTS

These charts are aids for quickly finding order numbers for System/360 and System/370 publications about a specific machine or programming system, except for those pertaining to the System/360 Model 20. The machine charts are arranged according to the numbers of the system models and the I/O devices. The programming charts are arranged to show prerequisite publications and categories of publications for a particular system. To determine the models of System/360 and/or System/370 to which an I/O device currently may attach, see IBM System/360 Input/Output Configurator, GA22-6823, and IBM System/370 Input/Output Configurator, GA22-7002. See IBM System/360 Model 20 Bibliography, GA26-3565, for information about System/360 Model 20 machines and programming systems.

Publication Description	Publication Order Number										
	Model 25	Model 30	Model 40	Model 44	Model 50	Model 65	Model 67	Model 75	Model 85	Model 91	Model 195
System Summary		GA22-6810 (for all models)									
System References		GA22-6821 (for all models)									
System Physical Planning Reference		GC22-6820 (for all models)									
Model Reference	GA24-3510	GA24-3231 (CPU) GA24-3411 (Channel)	GA22-6881	GA22-6875	GA22-6898	GA22-6884	GA27-2719	GA22-6889	GA22-6916	GA22-6907	GA22-6943
Model Configurator	GA24-3511	GA24-3232	GA22-6813	GA22-6874	GA22-6814	GA22-6887	GA27-2713	GA22-6888	GA22-6920	(in GA22-6907)	GA22-6944
Model Operating Procedures	GA24-3523	GA24-3373	GA22-6911	GA22-6910	GA22-6908	GA27-2728		GA22-6909	GA22-6927		GA22-6954
Model Physical Planning Template	GX22-6894	GX22-6894	GX22-6894	GX22-6914	GX22-6914	GX22-6856 GX22-6924	GX22-6905	GX22-6856	GX22-6923		GX22-6981
I/O Reference		See separate I/O chart.									
I/O Configurator		GA22-6823 (for all models)									
OEMI: Channel-to-Control Unit Interface		GA22-6843 (for all models)									
OEMI: Power Control Interface		GA22-6906 (for all models except 91)									
OEMI: Direct Control Feature		GA22-6845 (for all models except 44)									
Channel-to-Channel Adapter Feature		GA22-6892 (for all models)									
Other Features	GA24-3512 GA24-3524 GA24-3526	GA24-3255 GA24-3365 GC20-1650	GL22-6902 GL22-6903 GL22-6904	GA22-6900	GA27-2717	GA27-2715 GA27-2716 GA27-2717	GA27-2715		GA27-2733		

Publication Description	Publication Order Number		
	Model 145	Model 155	Model 165
System Summary		GA22-7001 (for all models)	
System Reference		GA22-7000 (for all models)	
System Physical Planning Reference		GA22-7004 (for all models)	
Model Reference	GA24-3557	GA22-6942 (CPU) GA22-6962 (Channel)	GA22-6945
Model Configurator		GA22-6957	GA22-6956
Model Operating Procedures	GA24-3554		
Model Physical Planning Template	GX22-7005	GX22-7006	GX22-7007
I/O Reference		See separate I/O chart.	
I/O Configurator		GA22-7002 (for all models)	
OEMI: Channel-to-Control Unit Interface		GA22-6843 (for all models)	
OEMI: Power Control Interface		GA22-6906 (for all models)	
OEMI: Direct Control Feature		GA22-6845 (for all models)	
Other Features			GA22-6955 GA22-6958

INPUT/OUTPUT

I/O Device or Control Unit	Publication Order Number		
	Reference Manual	OEM Manual	Physical Planning Template
50 Magnetic Data Inscriber Model 1	GA27-2725		
1017 Paper Tape Reader Models 1, 2	GA33-4500		GX22-6834
1018 Paper Tape Punch Model 1	GA33-4500		GX22-6834
1051 Control Unit Models 1, N1	*	*	GX22-6894 GX24-3381
1052 Printer-Keyboard Models 3, 5, 8	*	*	
1052 Printer-Keyboard Model 7	GA22-6877		GX22-6894
1053 Printer Models 1, 4	*	*	GX22-6894
1231 Optical Mark Page Reader Model N1	GA21-9031 (GA21-9012)		GX22-6860
1255 Magnetic Character Reader Models 1-3	GA24-3542		
1259 Magnetic Character Reader Model 2	GA24-3500		GX22-6860
1285 Optical Reader Model 1	GA24-3256		GX22-6860
1287 Optical Reader Models 1-4	GA21-9064		GX22-6860
1288 Optical Page Reader Model 1	GA21-9081		GX22-6860
1403 Printer Models 2, 3, 7, N1	GA24-3073 (GA24-3488)	GA24-1431	GX22-6834
1404 Printer Model 2	GA24-1446	GA24-3356	GX22-6834
1412 Magnetic Character Reader Model 1	GA24-1421		GX22-6860
1418 Optical Character Reader Models 1, 2	GA24-1473 (GA24-1452) (GA24-3081)		GX22-6860
1418 Optical Character Reader Model 3	GA24-1473 GA24-3059 (GA24-1452) (GA24-3081)		GX22-6860
1419 Magnetic Character Reader Model 1	GA24-1499 (GA24-3342)		GX22-6860
1428 Alphameric Optical Reader Models 1, 2	GA24-1473 (GA24-1452) (GA24-3081)		GX22-6860
1428 Alphameric Optical Reader Model 3	GA24-1473 GA24-3059 (GA24-1452) (GA24-3081)		GX22-6860
1442 Card Read Punch Model N1	GA21-9025		GX22-6834
1442 Card Punch Model N2	GA21-9025		GX22-6834

Publications shown in parentheses are related but not primary references.

*See IBM SRL Bibliography Supplement — Teleprocessing, Order Number GA24-3089.

INPUT/OUTPUT (continued)

I/O Device or Control Unit	Publication Order Number		
	Reference Manual	OEM Manual	Physical Planning Template
1443 Printer Model N1	GA24-3120 (GA24-3488)		GX22-6834
1445 Printer Model N1	GA24-3120		GX22-6834
1827 Data Control Unit Model 1	GA22-6868 (GA22-6872)		GX26-5508
2150 Console Model 1	GA22-6877		GX22-6859
2250 Display Unit Model 1	GA27-2701		GX22-6859
2250 Display Unit Model 3	GA27-2721		GX22-6859
2260 Display Station Models 1, 2	GA27-2700 (GC20-1688)		GX22-6859
2285 Display Copier Model 1	GA27-2730		GX22-6859
2301 Drum Storage Model 1	GA22-6895 (GC20-1649)	GA26-5661	GX22-6858
2302 Disk Storage Models 3, 4	GA26-5988 (GC20-1649)		GX22-6858
2303 Drum Storage Model 1	GA26-5988	GA26-5663	GX22-6858
2305 Fixed-Head Storage Models 1, 2	GA26-1589		
2311 Disk Storage Drive Model 1	GA26-5988 (GC20-1649)	GA26-3567	GX22-6858
2314 Direct Access Storage Facility Model 1, A Series, and B Series	GA26-3599 (GC20-1649)		GX22-6858
2321 Data Cell Drive Model 1	GA26-5988 (GA26-3633) (GC20-1649)	GA26-3674	GX22-6858
2401 Magnetic Tape Unit Models 1-6, 8	GA22-6866	GA22-6862	GX22-6855
2415 Magnetic Tape Unit and Control Models 1-6	GA22-6866		GX22-6855
2420 Magnetic Tape Unit Model 5	GA32-0007		GX22-6855
2420 Magnetic Tape Unit Model 7	GA22-6918		GX22-6855
2495 Tape Cartridge Reader Model 1	GA27-2726		GX22-6855
2501 Card Reader Models B1, B2	GA21-9026		GX22-6834
2520 Card Read Punch Model B1	GA21-9027		GX22-6834
2520 Card Punch Models B2, B3	GA21-9027		GX22-6834
2540 Card Read Punch Model 1	GA21-9033		GX22-6834
2560 Multifunction Card Machine Model A1	GA26-5893		GX22-6894

Publications shown in parentheses are related but not primary references.

INPUT/OUTPUT (continued)

I/O Device or Control Unit	Publication Order Number		
	Reference Manual	OEMI Manual	Physical Planning Template
2671 Paper Tape Reader Model 1	GA24-3388		GX22-6834
2701 Data Adapter Unit Model 1	GA22-6864	GA22-6844	GX22-6857
2702 Transmission Control Model 1	GA22-6848	GA27-3012	GX22-6857
2703 Transmission Control Model 1	GA27-2703	GA27-3012	GX22-6857
2803 Tape Control Models 1, 2, 3	GA22-6866		GX22-6855
2804 Tape Control Models 1, 2, 3	GA22-6866		GX22-6855
2816 Switching Unit Model 1	GA22-6866		GX22-6855
2820 Storage Control Model 1	GA22-6895		GX22-6858
2821 Control Unit Models 1-5	GA24-3312		GX22-6834
2822 Paper Tape Reader Control Model 1	GA24-3388		GX22-6834
2826 Paper Tape Control Models 1, 2	GA33-4500		GX22-6834
2835 Storage Control Models 1, 2	GA26-1589		
2840 Display Control Model 2	GA27-2721		GX22-6859
2841 Storage Control Model 1	GA26-5988		GX22-6858
2844 Auxiliary Storage Control Model 1	GA26-3599		GX22-6858
2848 Display Control Models 1-3, 21, 22	GA27-2700 (GC20-1688)		GX22-6859
3210 Console Printer-Keyboard Models 1, 2	GA24-3552		GX22-7006
3211 Printer	GA24-3543		
3215 Console Printer-Keyboard Model 1	GA24-3550		GX22-7006
3330 Disk Storage Model 1	GA26-1592		
3420 Magnetic Tape Unit Models 3, 5, 7	GA32-0012		
3803 Tape Control Model 1	GA32-0012		
3811 Control Unit	GA24-3543		
3830 Storage Control Model 1	GA26-1592		
7770 Audio Response Unit Model 3	GA27-2712	GA27-2706	GX22-6857
7772 Audio Response Unit Model 3	GA27-2711 (GA27-2710)	GA27-2706	GX22-6857

Publications shown in parentheses are related but not primary references.

BASIC OPERATING SYSTEM

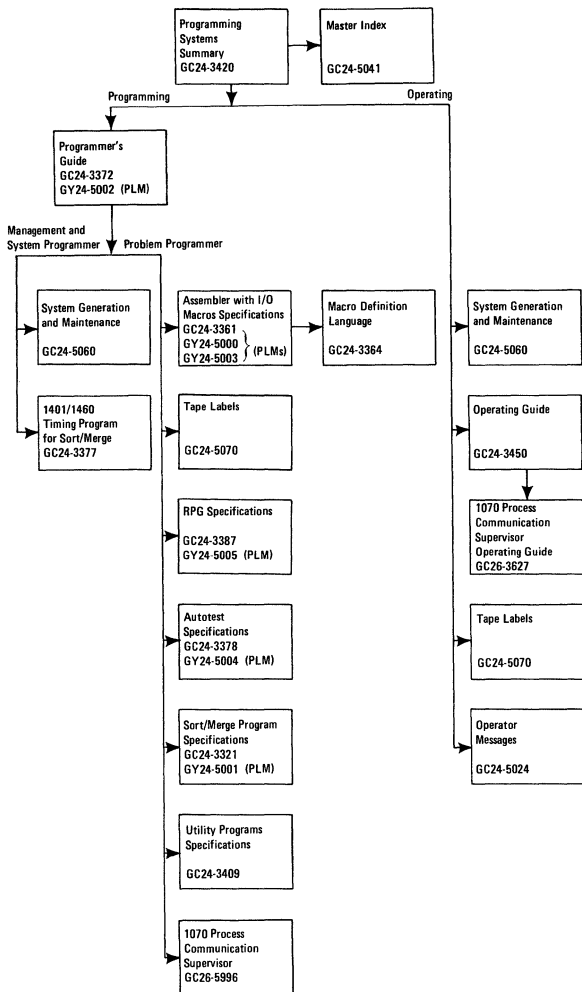

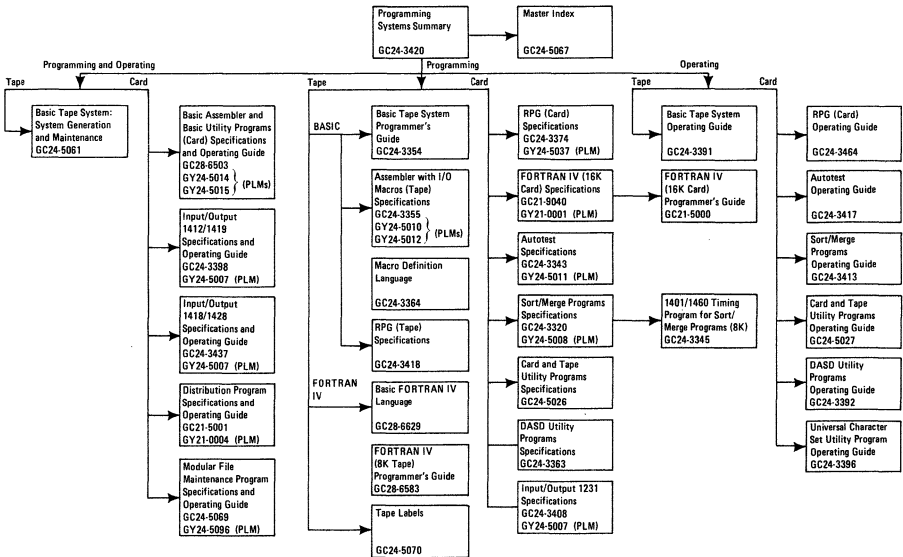

TAPE OPERATING SYSTEM

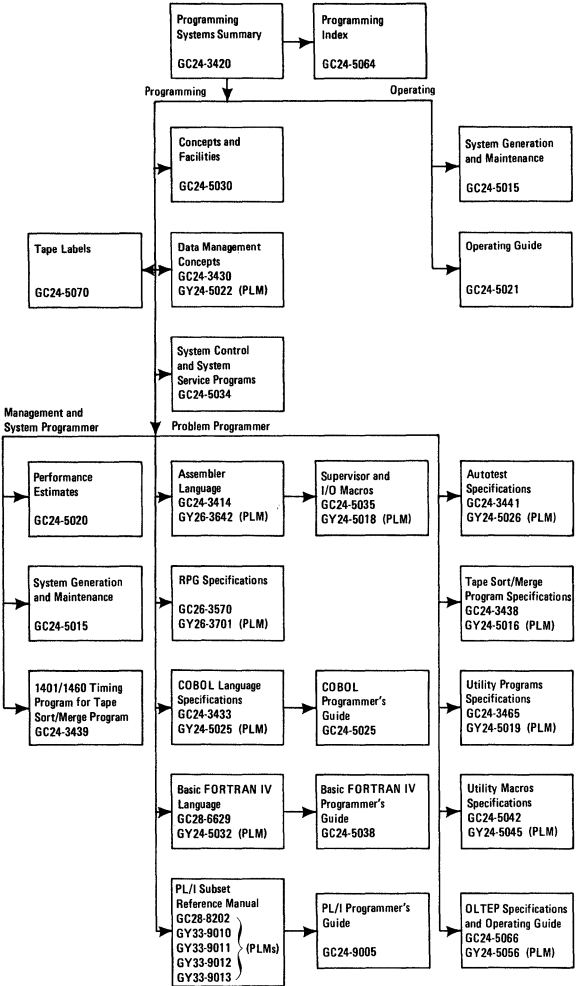

DISK OPERATING SYSTEM (continued)

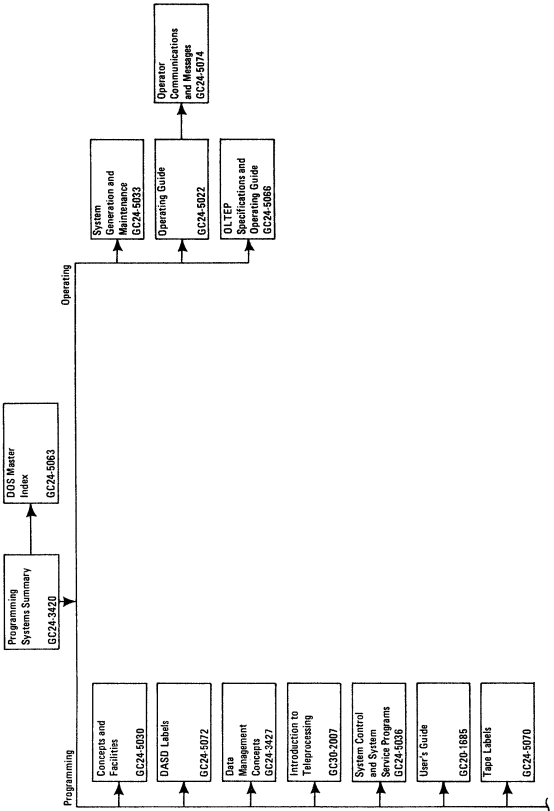

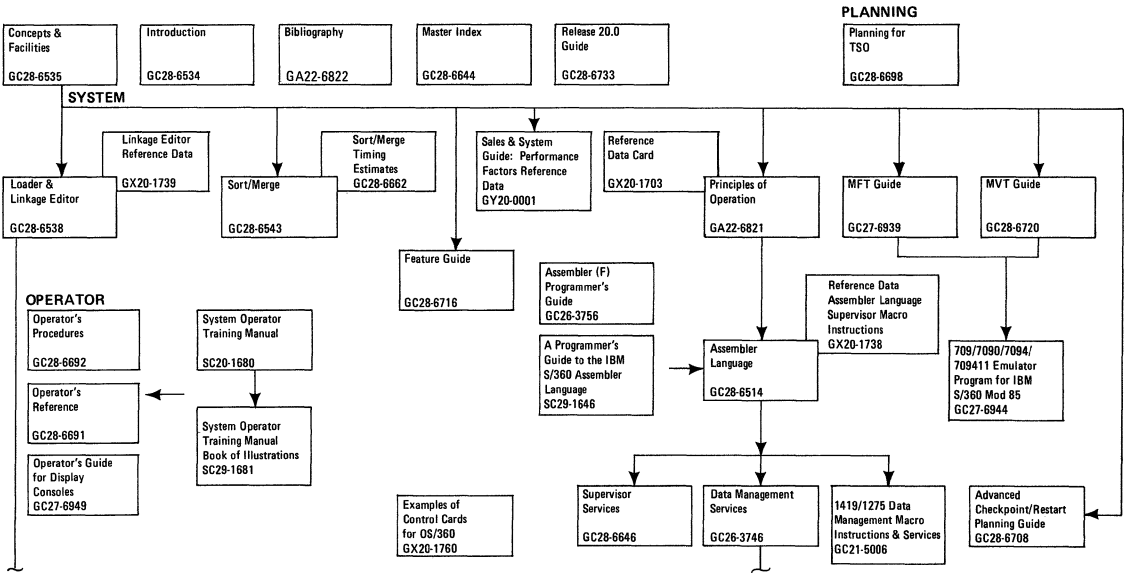

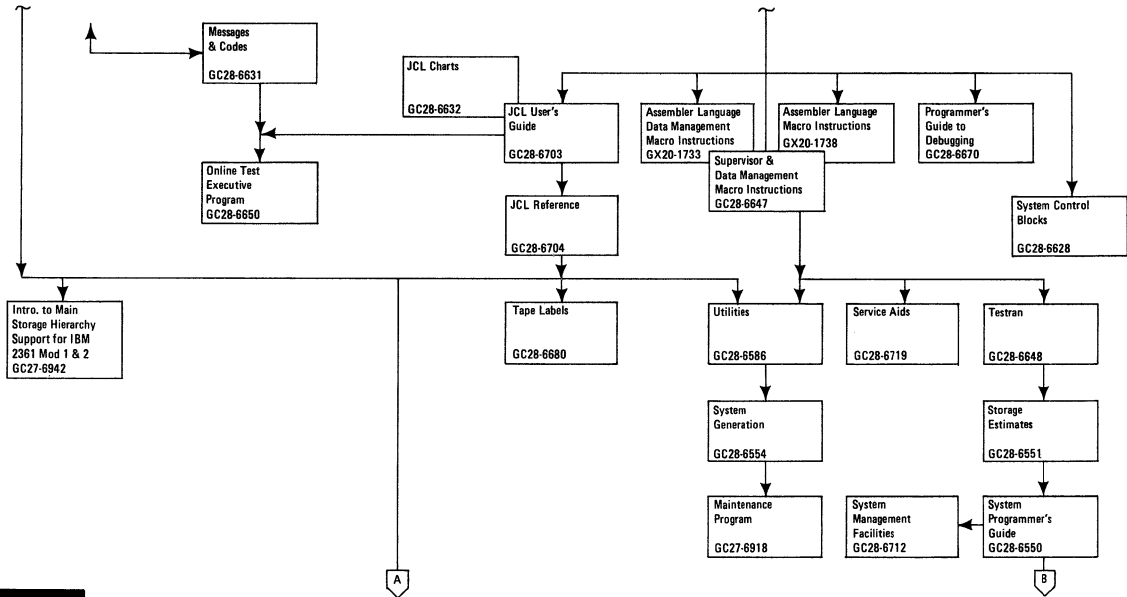

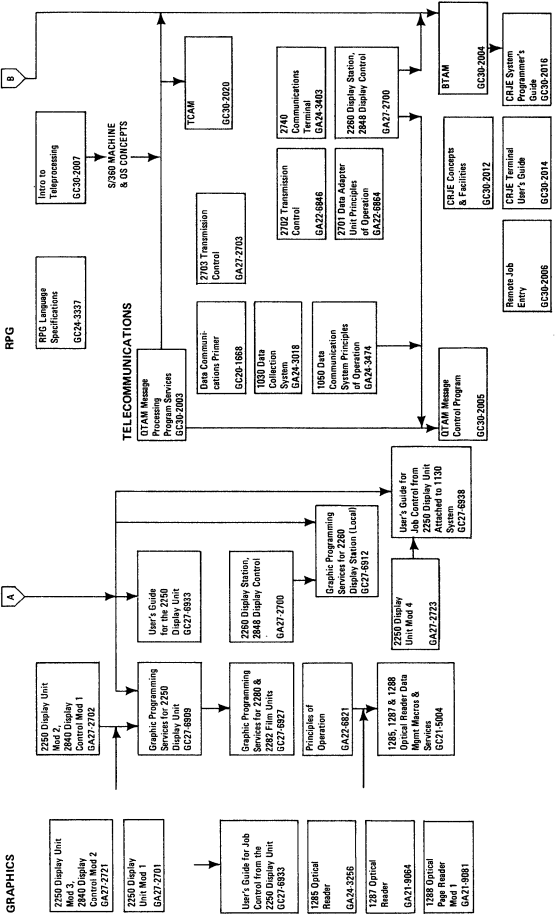

FORTRAN

KNOWLEDGE OF FORTRAN

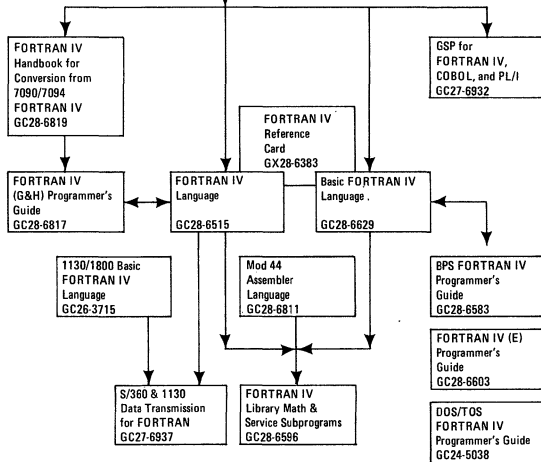

COBOL

KNOWLEDGE OF COBOL

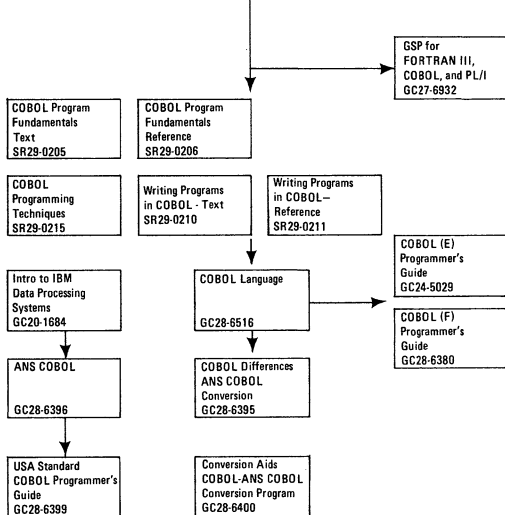

PL/I

KNOWLEDGE OF PL/I

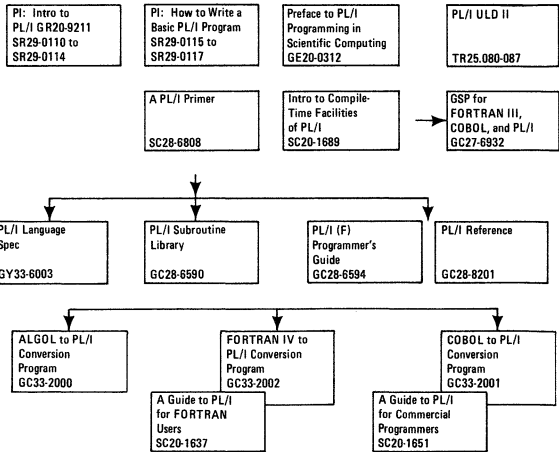

ALGOL

KNOWLEDGE OF ALGOL



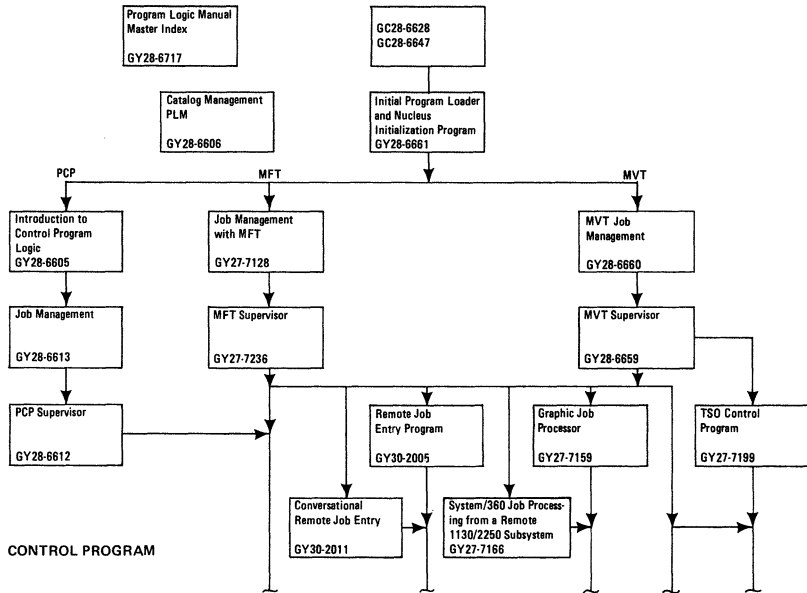

CONTROL PROGRAM

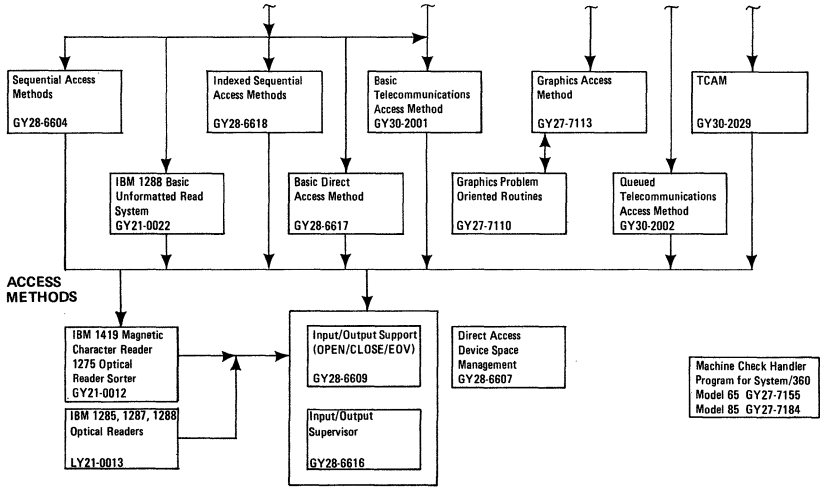

DEVICE SUPPORT & SUPERVISION

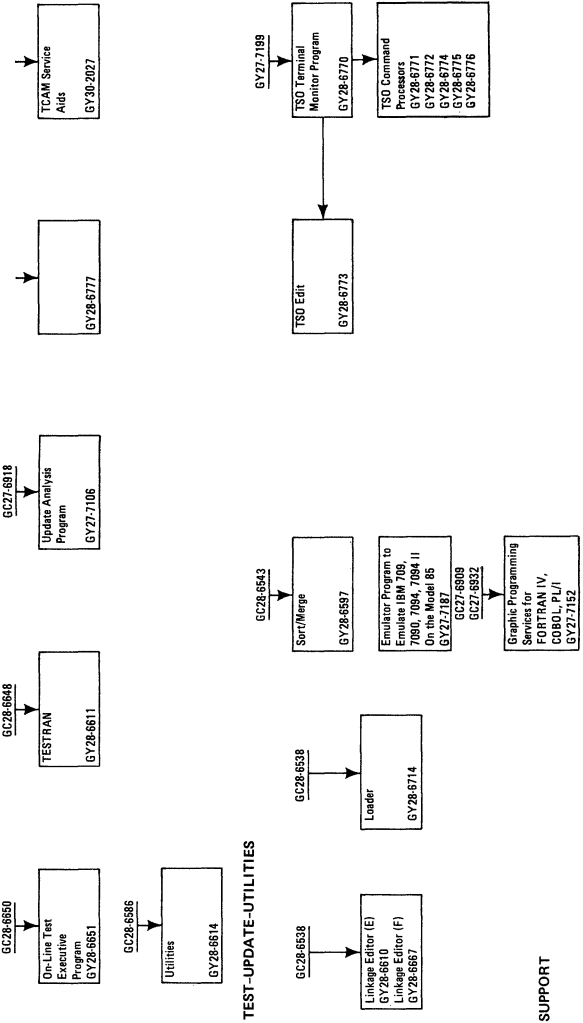

TEST-UPDATE-UTILITIES

SUPPORT

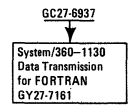
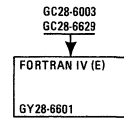
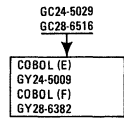
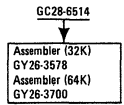
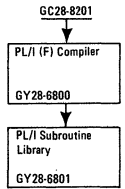
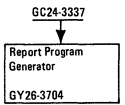

ASSEMBLER

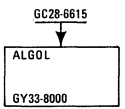
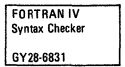

PL/I

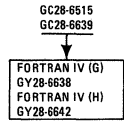
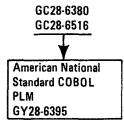

ASSEMBLERS, COMPILERS

COBOL

FORTRAN

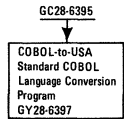
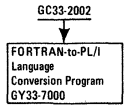
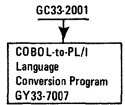
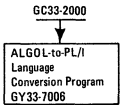

LANGUAGE CONVERSION PROGRAMS

TIME SHARING SYSTEM - SRLs

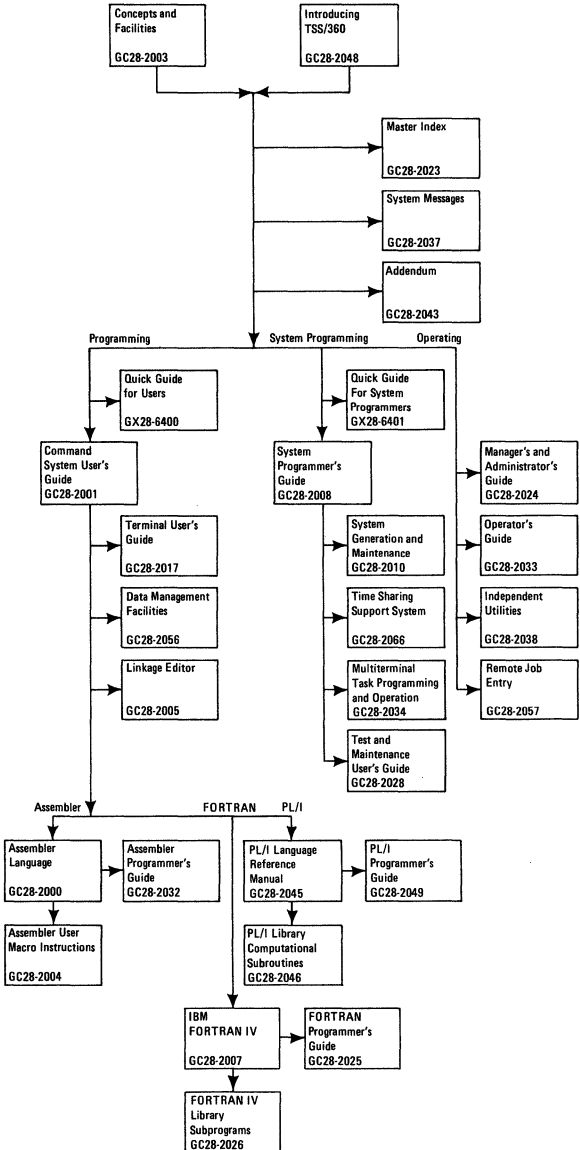

TIME SHARING SYSTEM - PLMs

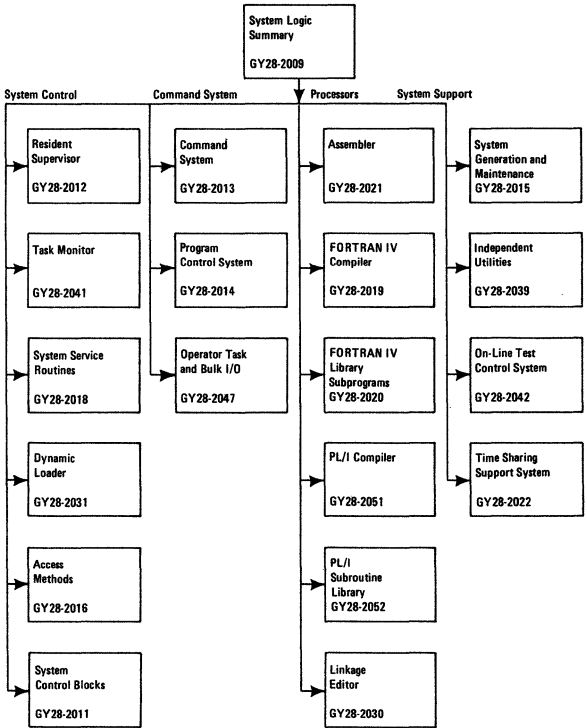

GLOSSARY OF TERMS

Not all of the terms listed here are used in this book, but sooner or later you will run across all of them, and be able to come back and look them up.

access method:

A technique for moving data between main storage and an input/output device.

address constant:

A number, or a symbol representing a number, used in calculating storage addresses.

alias:

Another name for a member of a partitioned data set; another entry point of a program.

allocate:

Assign a resource to a job or task.

asynchronous:

Without regular time relationship; unexpected or unpredictable with respect to the execution of a program's instructions.

attach (task):

To create a task control block and present it to the supervisor.

attribute:

A trait; for example, attributes of data include record length, record format, data set name, associated device type and volume identification, use, creation date, etc.

auxiliary storage:

Data storage other than main storage.

basic access method:

Any access method in which each input/output statement causes a machine input/output operation to occur. (The primary macro instructions used are READ and WRITE.)

batch processing:

(See stacked job processing.)

block (records):

1. To group records to conserve storage space or to increase the efficiency of access or processing.
2. A blocked record.
3. A portion of a telecommunications message defined as a unit of data transmission.

block loading:

Bringing the control section of a load module into adjoining positions of main storage.

buffer (program input/output):

A portion of main storage into which data is read, or from which it is written.

catalog:

1. The collection of all data set indexes maintained by data management.
2. To include the volume identification of a data set in the catalog.
3. In DOS to add a program to a library.

cataloged data set:

A data set that is represented in an index or series of indexes.

cataloged procedure:

A set of job control statements in the SYS1.PROCLIB data set. The procedure can be used by naming it in an execute (EXEC) statement.

CAW (channel address word):

A word in main storage at location 72 that specifies the location in main storage where a channel program begins.

CCW (channel command word):

A double word at the location in main storage specified by the CAW. One or more CCWs make up the channel program that directs channel operations.

CE cell:

A data cell used to test an IBM 2321. A CE cell is recognized by a sense to bin 0, subcell 19. If the CE sense bit is on, the CE cell is mounted.

CE pack:

A disk pack used to test an IBM 2311 or 2314. It has an R0 data length of 6 at any location other than cylinder 0, track 0.

CE volume:

If the device is a 2311 or 2314, see CE pack. If the device is a 2321, see CE cell.

channel:

A hardware device that connects the CPU and main storage with the I/O control units.

communications interval:

A period of communication between the console operator and OLTEP. The operator is requested by OLTEP to enter the test-run definition at this time.

concatenated data set:

A group of logically connected data sets.

Configuration Data Set (CDS):

A record of information about an I/O device or CPU accessed by OLTEP and the CLT.

control blocks:

A storage area used by the operating system to hold control information.

control dictionary:

The external symbol dictionary and relocation dictionary, collectively, of an object or load module.

control program:

The routines in the operating system that manage resources, implement data organization and communications conventions, or contain privileged operations.

control section:

That part of a program specified by the programmer to be a relocatable unit, all of which is to be loaded into adjoining main storage locations.

control volume:

A volume that contains one or more indexes of the catalog.

CPU (central processing unit):

The unit of a system that contains the circuits that control and perform the execution of instructions.

CRT (Cathode Ray Tube):
Visual Display Screen.

CSW (channel status word):

A word in main storage at location 64 that provides information about the termination of an input/output operation.

data management:

Those parts of the control program that provide access to data sets, enforce data storage conventions, and regulate the use of input/output devices.

data organization:

The arrangement of a data set.

data protection:

A safeguard invoked to prevent the loss or destruction of customer data.

data security:

A safeguard invoked to prevent the accessing of customer data.

data set:

The major unit of data storage and retrieval in the operating system, consisting of a collection of data in one of several prescribed arrangements and described by control information that the system has access to.

data set control block (DSCB):

A data set label for a data set in direct-access storage.

data set label (DSL):

A collection of information that describes the attributes of a data set, and that is normally stored with the data set; a general term for data set control blocks and tape data set labels.

default value:

A predetermined value used in place of an omitted entry.

deferred entry:

An entry into a subroutine that occurs as a result of a deferred exit from the program that passed control to it.

deferred exit:

The passing of control to a subroutine at a time determined by an asynchronous event rather than at a predictable time.

device independence:

The ability to request input/output operations without regard to the characteristics of the input/output devices.

device name:

Usually, the general name for a kind of device, specified at the time the system is generated. For example, 2311 or 2400 or TAPE. (See Unit name.)

direct access:

Retrieval or storage of data by a reference to its location on a volume, rather than relative to the previously retrieved or stored data.

dispatching priority:

A number assigned to tasks to determine the order in which they will use the central processing unit in a multitask situation.

dump (main storage):

1. To copy the contents of all or part of main storage onto an output device, so that it can be examined. 2. The data resulting from 1. 3. A routine that will accomplish 1.

entry point:

Any location in a program to which control can be passed by another program.

event:

An occurrence of significance to a task; typically, the completion of an asynchronous operation, such as input/output.

exchange buffering:

A technique using data chaining to avoid moving data in main storage, in which control of buffer segments and user program work areas is passed between data management and the user program.

exclusive segments:

Segments in the same region of an overlay program, neither of which is in the path of the other. They cannot be in main storage simultaneously.

execute (EXEC) statement:

A job control statement that designates a job step by identifying the load module to be fetched and executed.

expiration date:

A date within a tape label for data protection. The tape cannot be used as a scratch tape without permission from the operator until this date has expired.

extent:

The physical locations on input/output devices occupied by or reserved for a particular data set.

external reference:

A reference to a symbol defined in another module.

external symbol:

A control section name, entry point name, or external reference; a symbol contained in the external symbol dictionary.

external symbol dictionary (ESD):

Control information associated with an object or load module which identifies the external symbols in the module.

fetch (program):

1. To load requested load modules into main storage, relocating them as necessary. 2. A control routine that accomplished 1.

F format:

A data set record format in which the logical records are the same length.

File Protect Mode (FPM):

A mode of operation that insures maximum protection and security of customer data. While in file protect mode, the system performs no write operations and reads no customer data.

generation data group:

A collection of successive, historically related data sets.

GPR (General purpose register):

Temporary storage with capacity of one word. There are 16 GPRs on System/360 computers.

IC (instruction counter):

Hardware circuit which tells the central processor (CPU) what main storage address to find the next instruction to execute.

inclusive segments:

Overlay segments in the same region that can be in main storage simultaneously.

index (data management):

1. A table in the catalog structure used to locate data sets. 2. A table used to locate the records of an indexed sequential data set.

initial program loading (IPL):

The initialization procedure which loads the nucleus and begins normal operations.

initiator:

The part of the job scheduler that selects jobs and job steps to be executed, allocates input/output devices for them, places them under task control, and at completion of the job, supplies control information for writing job output on a system output unit.

input stream:

Job control statements entering the system; may also include input data.

input queue:

A queue of job information the job scheduler uses to select the jobs and job steps to be processed.

installation:

A particular computing system, in terms of the overall work it does and the people who manage it, operate it, apply it to problems, service it, and use the results it produces.

interrupt:

An asynchronous occurrence which causes the central processor (CPU) to cease its normal execution of instructions and store the Current Program Status Word (PSW). A new PSW is utilized and it in turn tells the Central Processor what main storage address to find the next instruction to execute. Interrupts are caused by several different and unrelated situations. One of these is the end of an I/O operation.

job:

A unit of work for the system from the stand-point of installation accounting and control. A job consists of one or more job steps.

job control statement:

A control statement in the input stream that identifies a job or defines its needs.

job library:

A set of user-identified partitioned data sets used as the main source of load modules for a given job.

job management:

A general term for the work done by the job scheduler and master scheduler.

job queue: (See input queue.)

job scheduler:

The part of the control program that controls input streams and system output, obtains input/output resources for jobs and job steps, attaches tasks corresponding to job steps, and otherwise regulates the use of the system by jobs. (See reader, initiator, output writer.)

job (JOB) statement:

The control statement in the input stream that identifies the beginning of a series of job control statements for a single job.

job step:

A unit of work associated with one processing program or one cataloged procedure, and related data.

language translator:

Any assembler, compiler, or other routine that accepts statements in one language and produces equivalent statements in another language.

library:

1. A collection of objects (for example, data sets, volumes, card decks) associated with a particular use, and identified in a directory. See job library, link library, system library. 2. Any partitioned data set.

limit priority:

A number associated with a task in a multitask operation, representing the highest dispatching priority that the task can assign to itself or to any of its subtasks.

link library:

A partitioned data set which, unless otherwise specified, is used in fetching load modules referred to in execute (EXEC) statements and in ATTACH, LINK, LOAD, and XCTL macro instructions.

linkage:

The way two routines or modules communicate.

linkage editor:

A program that produces a load module by changing object modules into a form acceptable to fetch, combining object modules and load modules into a single new load module, resolving symbolic cross references among them, replacing, deleting, and adding control sections automatically on request, and providing overlay facilities for modules requesting them.

load:

To read a load module into main storage.

load module:

The output of the linkage editor; a program in a form suitable for loading into main storage for execution.

locate mode:

A way of providing data by pointing to its location instead of moving it.

logical record:

A record that is defined in terms of the information it contains rather than by its physical traits.

macro instruction:

A macro instruction statement, the corresponding macro instruction definition, the resulting assembler language statements, and the machine language instructions and other data produced from the assembler language statements; loosely, any one of these representations of a machine language instruction sequence.

main storage:

All addressable storage from which instructions can be executed or from which data can be loaded directly into registers.

master scheduler:

The part of the control program that responds to operator commands and returns required information.

MFT:

Multiprogramming with a fixed number of tasks.

MFT2:

Improvement on MFT which orients it with MVT (see below).

Micro program:

Generated by IBM and stored in the ROS (Read Only Storage) area of the CPU (Central Processing Unit). Used by the CPU to decode instructions (see ROS for further definition).

module (programming):

A program unit that is input to, or output from, a single execution of an assembler, compiler, or linkage editor; a source, object, or load module.

move mode:

A way of providing data by moving it instead of pointing to its location.

multijob operation:

Concurrent execution of job steps from two or more jobs.

multiprogramming:

Using main storage for more than one program at a time.

multitask operation:

Multiprogramming; called multitask operation to express parallel processing not only of more than one program, but also of a single reenterable program used to do many tasks.

MVT:

Multiprogramming with a variable number of tasks.

name:

A set of one or more characters that identifies a statement, data set, module, etc., and that is usually associated with the location of that which it identifies.

nucleus:

That part of the control program that must always be present in main storage. Also, the main storage area used by the nucleus and other transient control program routines.

object module:

The output of a single execution of an assembler or compiler, which constitutes input to linkage editor. An object module consists of one or more control sections in relocatable, though not executable, form and an associated control dictionary.

On-Line Test (OLT):

A test program of the on-line test system. The tests reside in the core image library, and are brought into core storage by OLTEP when requested by the operator.

On-Line Test Executive Program (OLTEP):

The control program of the on-line test system. OLTEP is the interface between the on-line test and the operating system.

on-line test system:

A control program, OLTEP, and a series of tests (OLTs) designed to test I/O devices while permitting normal system processing in the foreground partitions.

operator command:

A statement to the control program, issued via a console device, which causes the control program to provide requested information, alter normal operations, initiate new operations, or terminate existing operations.

output queue:

A collective term for the 36 queues of control information describing system output data sets. These queues specify to an output writer the location and disposition of system output. Each of the 36 queues is associated with one output class.

output writer:

A part of the job scheduler that writes output data sets onto a system output unit, independently of the program that produced such data sets.

overlay:

To place a load module or a segment of a load module into main storage locations occupied by another load module or segment.

overlay (load) module:

A load module that has been divided into overlay segments, and has been provided by linkage editor with information that enables overlay supervisor to load the desired segments when requested.

overlay segment: (See segment.)

overlay supervisor:

A control routine that controls fetching of overlay segments on the basis of information recorded in an overlay module by linkage editor.

parallel processing:

Concurrent execution of one or more programs.

partition:

In systems with MFT, an area of main storage set aside for a job.

Partitioned data set:

A data set divided into several members. Each member has a unique name and is listed in a directory at the beginning of the data set. Members can be added or deleted as needed. Records within members are organized sequentially.

path:

A series of segments that form the shortest distance in a region between a given segment and the root segment.

PCP (primary control program):

The basic control program, which provides sequential scheduling with no multiprogramming.

physical record:

A record that is defined in terms of physical qualities rather than by the information it contains.

polling:

A technique by which each of the terminals sharing a communications line is periodically checked to determine if it requires servicing.

post:

Note the occurrence of an event.

private library (of a job step):

A partitioned data set other than the link library or the job library.

privileged instruction:

An instruction that can be executed only while the CPU is in the supervisor state. Protection, I/O, direct control, and any instructions that manipulate the program status words are privileged.

problem program:

A routine that solves problems, monitors industrial processes, sorts and merges records, performs computations, processes transactions against stored records, etc., as opposed to a control program or a language translator.

processing program:

Any program, such as a problem program or a language translator, other than a control program.

prompting:

A request for help made by the operator when entering the test-run definition. OLTEP prints examples of the field requested by the operator.

PSW (program status word):

A double word in main storage used to control the order in which instructions are executed, and to hold and indicate the status of the system in relation to a particular program.

qualified name:

A data set name that is composed of multiple names separated by periods (for example, TREE.FRUIT.APPLE).

qualifier:

All names in a qualified name other than the rightmost, which is called the simple name.

queued access method:

An access method that automatically governs the movement of data between the program using the access method and input/output devices. (The primary macro instructions used are GET and PUT.)

Quiesce Mode:

A mode of operation that requires the foreground partition to be stopped by the operator. The operator does this on the console by issuing the PAUSE EOJ and STOP commands when requested by OLTEP.

reader:

The part of the job scheduler that analyzes an input stream.

ready condition:

The condition of a task that is ready to be performed by the central processing unit.

real time (interval timer):

Actual time.

record:

A unit of data.

reenterable:

A program concurrently usable by two or more tasks.

region:

In systems with MVT, an area of main storage set aside for a job step task or a system task.

relocation:

The changes of address constants required when a change of origin of a module or control section is made.

relocation dictionary:

That part of an object or load module which identifies all relocatable address constants in the module.

resource:

Any facility of the system required by a job or task, including main storage, input/output devices, the central processing unit, data sets, and control and processing programs.

resource manager:

Any control program routine responsible for the handling of a resource.

return code:

A number placed in a designated register (the "return code register") at the completion of a program. The number is established by user-convention and may be used to influence the execution of succeeding programs or, in the case of an abnormal end of task, it may simply be printed for programmer analysis.

return code register:

A register in which a user-specified condition code is placed at the completion of a program.

reusable:

Usable by two or more tasks. (See reenterable, serially reusable.)

root segment:

The first segment in an overlay program.

ROS (read only storage):

A data retrieval technique which is utilized by System/360, Models: 20, 30, 40, 50 and 65 for the purpose of instruction decoding. The central processor unit (CPU) takes an instruction from main storage and shows it to ROS. ROS tells the CPU how to perform that instruction.

scatter loading:

Placing the control sections of a load module into non-adjointing positions of main storage.

scheduler:

(See master scheduler and job scheduler.)

secondary storage:

Auxiliary storage.

seek:

Position the access mechanism of a direct-access device at a specified location.

segment:

1. The smallest unit (one or more control sections) that can be loaded during execution of an overlay program. 2. As applied to telecommunications, a portion of a message that can be contained in a buffer.

serially reusable:

Usable by another task after the current use has been concluded.

short block:

A block of F format data which contains fewer logical records than are standard for a block.

simple buffering:

A technique for controlling buffers in such a way that the buffers are assigned to a single data control block.

simple name:

The rightmost component of a qualified name (for example APPLE is the simple name in TREE.FRUIT.APPLE).

source module:

A series of statements which make up the entire input to a single execution of an assembler or compiler.

stacked job processing:

A technique that permits multiple job definitions to be grouped (stacked) for presentation to the system, which automatically recognizes the jobs, one after the other.

storage block:

An area of main storage consisting of 2048 bytes to which a storage key can be assigned.

subtask:

A task that is created by another task by means of the ATTACH macro instruction.

supervisor:

The key controlling part of the operating system. The supervisor governs the use of the main frame - the central processing unit and main storage.

supervisor state:

The state of CPU operation that allows execution of privileged instructions. When bit 15 of the PSW is zero, the CPU is in the supervisor state.

SVC (supervisor call):

An instruction which causes an SVC interruption in the hardware to give control to a control program routine (called an SVC routine) for some specific action, such as re-assigning parts of main storage or retrieving data from an I/O device.

synchronous:

Occurring with a regular or predictable time relationship.

sysin:

A system input stream.

SYSOUT:

A system output stream.

system input unit:

A device specified as a source of an input stream.

system library:

The collection of all cataloged data sets at an installation.

system macro instruction:

A macro instruction that provides access to operating system facilities.

system output unit:

An output device shared by all jobs.

system residence volume:

The volume on which important operating system routines and data are located.

SYSCTLG:

An optional system data set on the primary system residence device containing addresses relating installation data set names to specific volume numbers.

SYS1.GENLIB:

A data set, normally kept offline, used for system generation.

SYS1.LINKLIB:

A system data set containing the system program modules that are not either permanently resident in main storage or resident in the SYS1.SVCLIB.

SYS1.LOGREC:

A system data set on the primary system residence device containing information regarding system failures.

SYS1.MODLIB:

A data set, normally kept offline, used for storing program modules during modification by processes such as linkage editing and system generation.

SYS1.NUCLEUS:

A system data set on the primary system residence device containing the IPL program and the primary nucleus.

SYS1.PROCLIB:

A data set containing cataloged procedures -- handy sets of control statements that can be called into use by EXEC statements.

SYS1.SVCLIB:

A system data set on the primary system residence device containing all of those SVC routines, I/O error recovery routines, and access method routines, that are not permanently resident in main storage.

SYS1.SYSJOBQE:

A system data set used by the scheduler as a storage and work area for information about the input and output streams. Contains the input queue and output queue.

task:

A unit of work for the central processing unit from the standpoint of the control program; the basic multiprogramming unit under the control program.

task dispatcher:

The control program routine that selects from the task queue the task that is to be performed by the central processing unit.

task management:

The work done by the supervisor; regulating the use of the central processing unit and resources other than input/output devices.

task queue:

A queue of all the task control blocks present in the system at any one time.

telecommunications:

Data transmission between a system and remotely located devices via a unit that performs format conversion and controls the rate of transmission.

teleprocessing:

A term associated with IBM telecommunications equipment and systems.

test-run definition:

Information requested by OLTEP at the various communications intervals. This information consists of the device to be tested, the test or test routines to be executed, and the options to be exercised.

test translator:

A facility that allows various debugging procedures to be specified in assembler language programs.

text:

The control sections of an object or load module.

throughput:

The rate at which work can be handled by a system.

transmittal mode:

The way the contents of an input buffer are made available to the program, and the way a program makes records available for output.

turnaround time:

The time between submission of a job to a computing center and the return of results.

U format:

A data set format in which blocks are of unknown length.

unit name:

Usually, the unit address of a particular device, specified at the time a system is installed. For example 191 or 293. (See device name.)

user:

Anyone who requires the services of a computing system.

V format:

A data set format in which logical records are of varying length and include a length indicator; and in which V format logical records may be blocked, with each block containing a block length indicator.

volume:

That part of a unit of storage media which is accessible to a single read/write mechanism.

volume table of contents (VTOC):

A table associated with a direct-access volume, which describes each data set on the volume.

wait condition:

The condition of a task that needs one or more events to occur before the task can be ready to be performed by the central processing unit.

wait state:

The state of the system when no instructions are being processed, but the system is not fully stopped. The system can accept I/O and external interruptions, and can be put through the IPL procedure.

IBM SYSTEM/360 OPERATOR'S REFERENCE GUIDE, FORM R20-1078-2

CIRCLE ONE OF THE COMMENTS AND EXPLAIN IN THE SPACE PROVIDED:

SUGGESTED ADDITION (PAGE____) SUGGESTED DELETION (PAGE____) ERROR (PAGE____)
EXPLANATION :

FIRST CLASS
PERMIT NO. 142

POUGHKEEPSIE, N.Y.

BUSINESS REPLY MAIL

NO POSTAGE STAMP NECESSARY IF MAILED IN U.S.A.

POSTAGE WILL BE PAID BY:

IBM Corporation
Education Center, Bldg. 005
South Road
Poughkeepsie, New York 12602

ATTENTION: Education Development - Publications Services, Dept. 78L





International Business Machines Corporation
Data Processing Division
1133 Westchester Avenue, White Plains, New York 10604
(U.S.A. only)

IBM World Trade Corporation
821 United Nations Plaza, New York, New York 10017
(International)

SR20-1078-3

Operator's Reference Guide

Printed in USA SR20-1078-3