

MDS Series 21

Operator's Guide





SERIES 21 OPERATOR'S GUIDE

**FOURTH EDITION
(Software Rel. 7.0)**

Copyright © 1978, Mohawk Data Sciences Corp.
© 1978, First Edition
© 1978, Second Edition
© 1978, Third Edition

THE INFORMATION AND DATA HEREIN MAY NOT BE
REPRODUCED IN WHOLE OR IN PART WITHOUT THE
WRITTEN PERMISSION OF MDS CORP.



TABLE OF CONTENTS

	Page
Key to Section Heads	xi
1. INTRODUCTION	
How to Use this Manual	1
Series 21 Overview	3
Diskette Overview	4
Tips and Precautions for Handling Diskettes	5
Diskette Drives	6
Operator Station: Keyboard and Display Screen	8
Program Control	12
Basic Operating Sequence	13
2. KEYBOARD	
Features	1
Illustration, Typewriter Style Keyboard	2
Illustration, Data Entry Style Keyboard	3
Illustration, Alternate Data Entry Style Keyboard	4
3. DISKETTE ORGANIZATION	
Tracks and Sectors	2
What Is a Dataset?	3
Index Track	3
New Diskette	4
Volume Label	4
Dataset Labels	4
Dataset Allocation	5

TABLE OF CONTENTS, continued

	Page
4. PROGRAM LOAD	
Initial Program Load	1
Error/Status Messages	5
5. FORMATTED DATA ENTRY PROGRAM (FDE)	
Introduction	3
Mode/Operation Selection	5
Set-up Sequence for ENTRY, VERIFY, and SEARCH	5
Job Load	7
ENTRY - Procedures	9
Figure V-1, Annotated Production Display	11
Using Automatic Fields	12
Correcting Errors During ENTRY	13
Special Functions	14
VERIFY - Procedures	15
Figure V-2, Annotated Production Display	17
About Automatic Fields	18
Correcting Errors During VERIFY	19
Special Functions	21
SEARCH - Procedures	25
UPDATE - Procedures	29
UTILITIES - Procedures	31
STATISTICS - Procedures	35
Description of Counters	36
Job Description	37
How to Create a Job Description	37
Illustration, Workflow Diagram	37

TABLE OF CONTENTS, continued

	Page
5. FORMATTED DATA ENTRY PROGRAM (FDE), continued	
Procedures for Coding a Job Description	37
About the Screen Layout Form	39
Figure V-3, FDE Screen Layout Form	39
Figure V-4, FDE Job Definition Keying Form	42
How to Enter a Job Description	47
Table V-1, Summary of Function Keys Available During ENTRY and VERIFY	50
6. BSC COMMUNICATIONS PROGRAMS	
Introduction	1
BSC2780	3
Introduction	3
Operating Mode Selection	4
Feature Selection	5
I/O Device Selection	7
Reset Counters	10
Transmit Mode	11
Figure VI-1, Key to Information on Activity Monitor Display	12
Receive Mode	16
Table VI-1, BSC2780 Operating Mode	18
Table VI-2, BSC2780 Feature Support	19
BSC3780	22
Introduction	22
Initiate	23
Feature Selection	24

TABLE OF CONTENTS, continued

	Page
6. BSC COMMUNICATIONS PROGRAMS, continued	
I/O Device Selection	25
Reset Counters	28
Transmit/Receive	29
Table VI-3, BSC3780 Functions	33
Table VI-4, BSC3780 Feature Support	34
Table VI-5, Device Select Field Entry Requirements	35
Table VI-6, Key to Activity Monitor Display	38
7. MOBOL COMPILER	
Description	2
Compiler Operation	3
MOBOLIST	6
Operation	8
8. MEDIA UTILITIES PROGRAM (MEDIAU)	
Introduction	1
Device Control	2
Table VIII-1, Table of Valid Input/Output Combinations	7
Data Transcription	8
Table VIII-2, Data Transcription Using MEDIAU	8
Magnetic Tape Utilities	14

TABLE OF CONTENTS, continued

	Page
9. DATA MANAGEMENT UTILITY PROGRAM (DMU)	
Introduction	1
Sort	2
Merge	6
Sequential Index	9
Random Index	11
Format Random Index	13
Parameters	15
10. DISKETTE UTILITIES PROGRAM (DSKETTEU)	
Introduction	1
DSKETTEU Function Select	2
Volume Label Functions	4
Diskette Initialization	5
Volume Naming	7
Designating Volume Accessibility	8
Data Set Label Functions	9
Data Set Label Creation	11
Reorganization of Space on Diskette	14
Table X-1, Description of Fields in Data Set Label Display	21
11. DISK UTILITIES PROGRAM (DISKU)	
Introduction	1
Disk Software Formatting	3
Volume Labeling Modification	4
New Data Set Label Creation	5
Data Set Label Modification	6
Figure X1-1, Description of Fields on Volume Catalog Display	9

TABLE OF CONTENTS, continued

	Page
12. PRINTER UTILITIES PROGRAM (PRINTERU)	
Introduction	1
Initial PRINTERU Display	2
Modification of Parameters	4
Storage of Modified Parameters	6
Table XII-1, Valid Entries for Parameter Modification	9
13. PERIPHERALS	
Introduction	1
Printers	2
2141 Model	2
2142-1 and 2142-2 Models	7
2145 Model	13
Tape Drives	27
2481 and 2482 Models	27
2181 and 2182 Models	31
Data-Recorders (Series 21 Interface)	35
1103 Model	40
6403 Model	43
7505 Model	45
Disk Drive	48
2172 Model	48
Compatible Channel	50

TABLE OF CONTENTS, continued

	Page
14. PROBLEM DETERMINATION	
Introduction	1
Controller Console	2
Display Screen	3
Diskette, Possible Defects	5
15. SYSTEM CONFIDENCE TEST	
16. MAINTENANCE	
Cleaning Controller and Operator Station	2
Air Filter Removal and Replacement	3
2181/2182 Magnetic Tape Drive	5
17. GLOSSARY	



INTRODUCTION

KEYBOARD

DISKETTE ORGANIZATION

PROGRAM LOAD

FORMATTED DATA ENTRY PROGRAM

BSC COMM PROGRAMS

MOBOL COMPILER; MOBOLIST PROGRAM

MEDIA UTILITIES PROGRAM

DATA MANAGEMENT UTILITY PROGRAM

DISKETTE UTILITIES PROGRAM

DISK UTILITIES PROGRAM

PRINTER UTILITIES PROGRAM

PERIPHERALS

PROBLEM DETERMINATION

CONFIDENCE TESTS

MAINTENANCE

GLOSSARY

KEY TO SECTION HEADS



INTRODUCTION

This manual describes operation of the MDS Series 21 systems, including the 21/20 and 21/40. These systems are part of the MDS Series 21 family of systems that are used to perform data processing functions such as data entry, customized data capture, data management, data editing, data conversion, transaction processing, and batch data communications.

How To Use This Manual

Read all general information, which applies to all Series 21 systems, such as the first four sections: INTRODUCTION, KEYBOARD, DISKETTE ORGANIZATION, and PROGRAM LOAD. These are intended to provide orientation and essential information to all operators of Series 21 systems. Also of general interest are the final five sections: PERIPHERALS, PROBLEM DETERMINATION, CONFIDENCE TESTS, MAINTENANCE, and GLOSSARY. Use these sections as reference, once their content has been scanned.

The remaining sections provide operating procedures for MDS-supplied programs that are available for Series 21 systems. Most operators will use FORMATTED DATA ENTRY (FDE) plus one or more of the other programs described. Here is a brief summary of the use of each program.

- **FORMATTED DATA ENTRY (FDE)** — Provides the ability to perform data entry, verify, and search/update. (May be used on 21/20 or 21/40 systems; no optional features or devices are required.)
- **COMMUNICATIONS PROGRAMS (COMM)** — BSC 2780 and BSC 3780) — Used to perform batch data communications. (May be used on 21/20 or 21/40 systems if equipped with optional Communications feature.)
- **MOBOL COMPILER (MOBOL)** — Used to compile user programs. To compile programs, the Series 21 system must be equipped with a minimum of two diskette drives. A 21/40 system (or a 21/20 system upgraded to 21/40) may be used to execute user programs. A program called MOBOLIST is used to display or print out user-written programs, annotated with errors (if any) detected by the system during compilation.
- **MEDIA UTILITIES (MEDIAU)** — Provides a number of data transcription, device control, and magnetic tape utility functions. (May be used on 21/20 or 21/40 systems; however, the use of functions require optional devices. Disk is not available on 21/20 systems.)

- **DATA MANAGEMENT UTILITIES (DMU)** — Provides a sort/merge function for disk or diskette record management; provides random and sequential index generation. (May be used on 21/20 or 21/40 systems equipped with a minimum of two diskette drives. Disk is not available on 21/20 system.)
- **DISKETTE UTILITIES (DSKETTEU)** — Provides functions for volume and data set labeling and allocation/deallocation of space on diskette. (Maybe used on 21/20 or 21/40 systems.)
- **DISK UTILITIES (DISKU)** — Provides a number of functions for controlling and accessing space on disk with Series 21 systems. Functions include initializing formatting, volume and data set labeling, allocation of space. (For use with 21/40 systems.)
- **PRINTER UTILITIES (PRINTERU)** — Provides functions to modify Series 21 default parameters for attached printers, including vertical forms control, horizontal forms control and VFU table. (May be used on 21/20 or 21/40 systems configured for MDS printer.)

The remaining sections are:

- **PERIPHERALS** — Describes the set-up and operation of optional peripheral devices and features.
- **PROBLEM DETERMINATION** — Use this section if a problem occurs while operating the system and recovery procedures for the problem are not in the program section you are using; see also MDS publication M-3925, *Series 21 Display Messages Manual for Rel. 7.0*.
- **CONFIDENCE TESTS** — Use this section when it is required to perform a System Confidence Test.
- **MAINTENANCE** — Use this section as reference for cleaning and routine maintenance of the system.
- **GLOSSARY** — Use this section to find the definition of many terms used in this manual.

SERIES 21 SYSTEMS

Systems 21/20 and 21/40 consist of an Operator Station and a Controller Console.

- The OPERATOR STATION consists of a display screen and a keyboard.

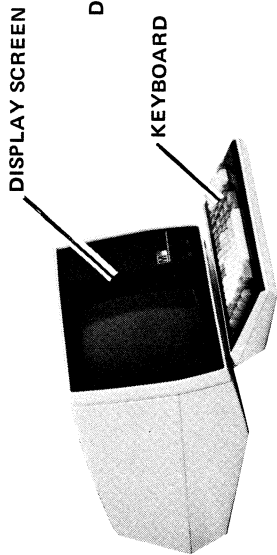

OPERATOR STATION

- The CONTROLLER CONSOLE is a cabinet that houses one or more diskette drives (4 maximum).

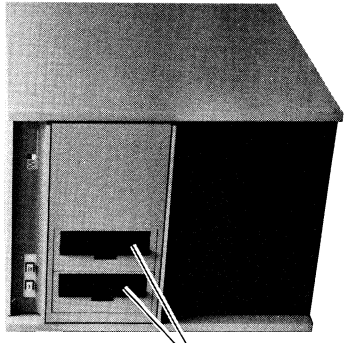

INSIDE CONTROLLER

- Processor
- Station
- Controller
- Device
- Controllers

CONTROLLER CONSOLE

THE DISKETTE

Series 21 systems use diskettes to store and read back information.

Each diskette is sealed in a protective jacket. The protective jacket covers most of the diskette recording surface, so that it is not damaged while being handled.

A diskette is **WRITE PROTECTED** if there is a rounded notch in the lower right corner of the protective jacket. To **WRITE ENABLE** a **WRITE PROTECTED** diskette, cover the notch completely with cellophane tape or label material.

An additional storage envelope is provided to store the diskette when it is not in use. When the diskette is removed from the storage envelope, it must be handled carefully.

Data Diskettes are used to

- **STORE** information you key enter into the system, and
- **RECOVER** information that was previously stored on diskette.

Special diskettes called "Library Diskettes" contain pre-recorded information that may be used to control operation of the system. This information, referred to as a program, is loaded into the system from the Library Diskette.

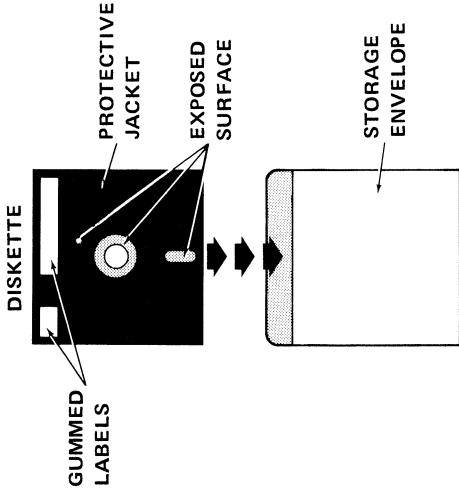

IMPORTANT TIPS AND PRECAUTIONS

1. Diskette Handling

- a. Keep diskette in storage envelope except when in use.
- b. Always handle the diskette by its sealed protective jacket, being careful not to touch the exposed diskette surface of the diskette itself.
- c. When inserting diskette into Diskette Drive of the Controller Console, hold diskette as illustrated on page 7. Insert diskette squarely and gently — never force.
- d. Never smoke, eat or drink while handling diskette.
- e. Never attempt to remove the diskette from its protective jacket.
- f. Never bend, fold, or staple the diskette or its protective jacket. Do not use paper clips or rubber bands on diskettes.
- g. Do not expose diskettes to extreme heat, dust, magnetic objects, or moisture, including furniture polish or spray.
- h. Never place the diskette on top of, or leaning against, the Display Screen.

2. Diskette Labels

- a. Always write on diskette label BEFORE adhering the label to the diskette's protective jacket. Writing pressure from a pen or pencil will damage the diskette.
- b. Never use erasers to remove/change information on a label already adhered to a diskette. Eraser dust could contaminate the diskette.
- c. Always remove old label before applying new one.
- d. When applying a new label, ensure that the label does not obstruct any openings in the diskette's protective jacket.
- e. Replace old diskette labels every six months so that adhesive does not harden, preventing removal of the label.

3. Diskette Storage

- a. Diskettes should be stored in the following environment:
 - Temp: 50° F (10° C) to 125° F (52° C)
 - Relative Humidity: 8% to 80%
- b. Long-term storage of diskettes should be in original shipping cartons; cartons should be stored flat. This will prevent damage from diskette sag.

DISKETTE DRIVES

Series 21 Controller Consoles have from one to four Diskette Drives, and they are given the following number assignments:

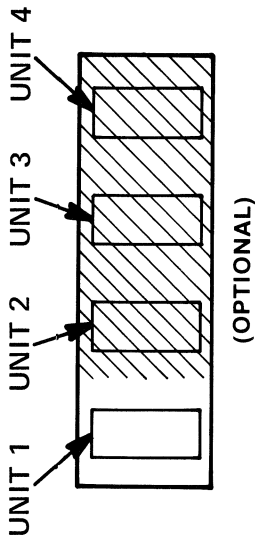

Series 21 programs require designation of the Unit Number of the diskette drive containing the diskette pertinent to the operation being performed.

Each operator station attached to a controller console may be assigned a number which relates to a specific diskette unit, as in example at right:

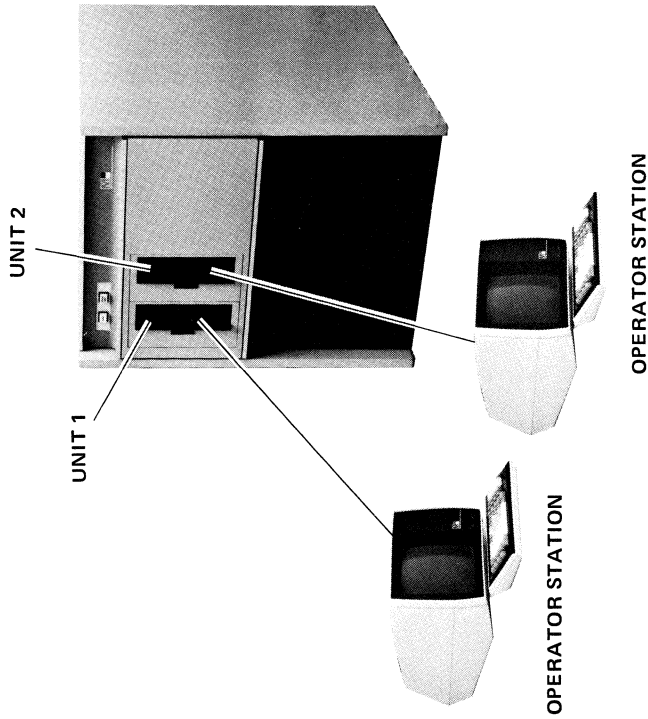

To Insert a Diskette in a Diskette Drive

1. Turn Controller Console power ON by pressing the POWER switch on the Controller Console.
2. Remove the diskette from the storage envelope.
3. Press the release button on the desired diskette drive to open the access door.
4. Hold the diskette so that the paper label is facing to the right, as illustrated. Insert the diskette steadily until it clicks. (Do not force the diskette into the drive).
5. Slide the access door to the left until a click is heard.

To Remove a Diskette From a Diskette Drive

1. Push the release button on the diskette drive containing the diskette to be removed.

NOTE:

- Do not push the release button if the red indicator light on the release button is lit.
- Remove the diskette and replace it in the storage envelope.

NOTE:

At the end of the work day, remove all diskettes and then press the POWER switch on the Controller Console to turn power off. Turn off each Operator Station.

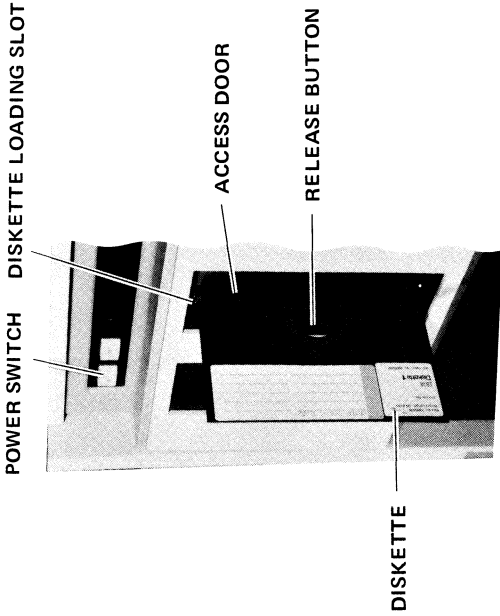

OPERATOR STATION (Keyboard Styles)

There are three different keyboard styles available:

- Typewriter Style,
- Data Entry Style, and
- Alternate Data Entry Style

All Operator Stations that are assigned to the same Controller Console have the same style keyboard.

TYPEWRITER KEYBOARD

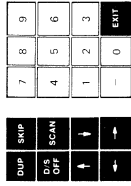
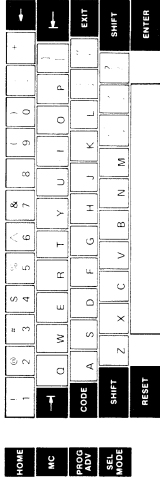

DATA ENTRY KEYBOARD

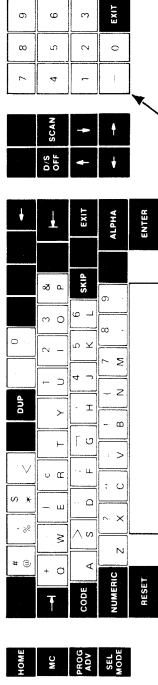

ALTERNATE DATA ENTRY KEYBOARD

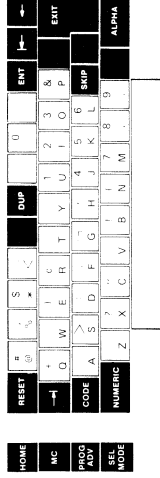

Any style keyboard may be equipped with an optional Numeric Pad. If your keyboard is equipped with this option, it is used like an adding machine (or calculator) keyboard.

Optional Numeric Pad



OPERATOR STATION (Display Screen Unit)

On the front of the Display Unit, which houses a "television-like" display screen, are two controls, and one indicator:

- Display Screen — The display screen presents information supplied by the system and keyed in through the keyboard.
- Brightness — The brightness control allows adjustment of the brightness of the characters displayed on the display screen.
- Volume — The volume control allows adjustment of the loudness of the audible tones that accompany each key depression and certain error conditions.
- Power On Indicator — The Power On Indicator illuminates when the Operator Station power is on.

At the rear of the Unit are two controls:

- Power Switch — The power switch applies power to and removes power from the operator station.
- Strobe Switch — This switch is used by MDS service personnel, and must be in the "down" position when the system is in use.

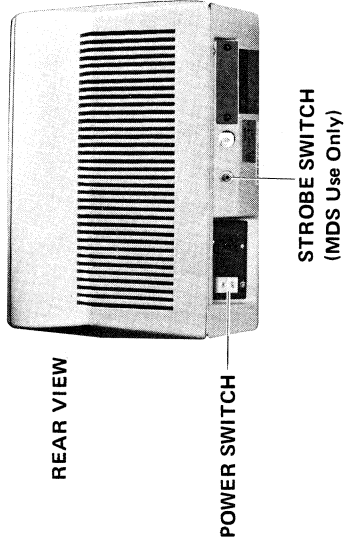
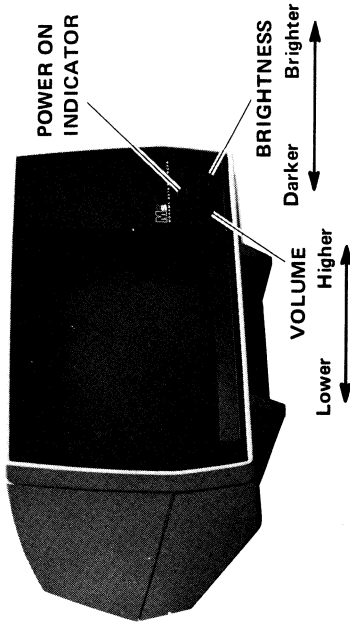

The display screen presents information in either 480-character or 1920-character formats.

- System 21/20 uses the 480-character display.
- System 21/40 may use either the 480 or the 1920-character display.

The program loaded into the system automatically selects the appropriate display formats.

Examples

480-Character Display

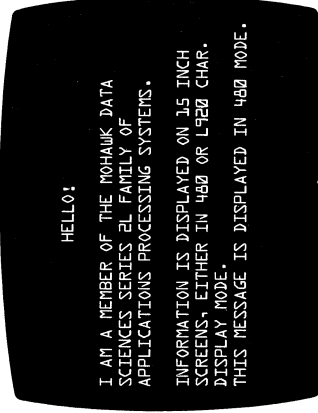

12 Lines X 40 Characters/Line

1920-Character Display

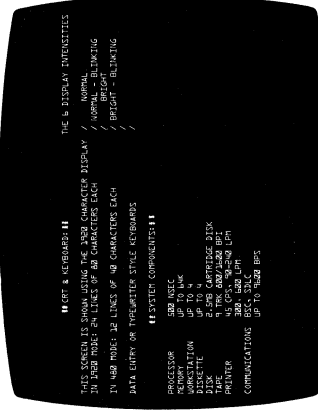

24 Lines X 80 Characters/Line

The display screen presents both system supplied and operator keyed information.

- System Supplied Information may be selection displays, guidance messages (referred to as prompts), error messages, and status information.
- Operator Keyed Information is data that you key enter into the system using the keyboard.

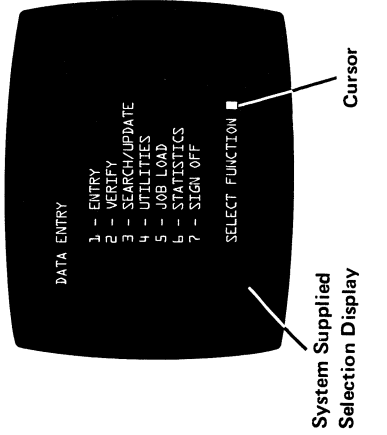

A blinking bright spot on the screen (called a cursor), indicates the screen position that will receive the next key entry. The cursor is a reference point that can be positioned with special keyboard keys in order to correct information keyed, or move from one field to another.

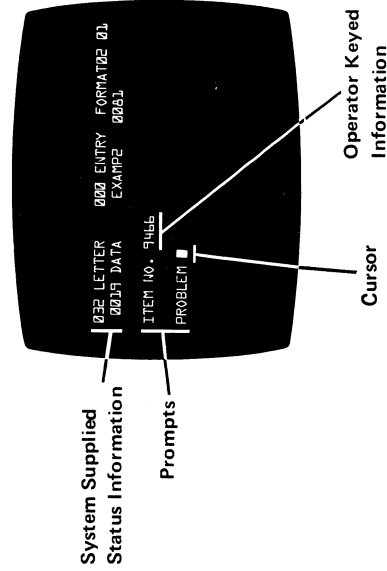

PROGRAM CONTROL

Series 21 systems operate under program control. A program is a series of instructions that can be loaded into the system. The MDS-supplied program loaded into the system defines the following:

PROGRAM

The Keyboard

- Defines how information you key is used, and the functions performed by special keys.

The Display Screen

- Defines how information is arranged on the screen.
- Defines system messages and selection displays for assisting you in performing operations.

Diskette Drives

- Defines how information is to be read from or recorded on diskette.

Operation

- Governs the function and use of the keyboard, display screen, and diskette drives to accomplish a specific task.
- Defines the use of optional devices if they are included in the system.

MDS supplies a number of prewritten programs for use on the System 21/20, 21/40 and 21/50.

BASIC OPERATING SEQUENCE

Operation of a Series 21 system consists of the following sequence:

1. POWER UP EQUIPMENT.
Controller Console
Operator Station
Peripheral equipment needed for desired operation
2. LOAD CONTROL PROGRAM.
3. LOAD APPLICATION PROGRAM.
4. PERFORM DESIRED APPLICATION/OPERATION.
5. SIGN OFF APPLICATION PROGRAM.
(Control is returned to Control Program; another Application Program may be selected if desired.)
6. POWER OFF EQUIPMENT (when shutting down system for the day).
Peripheral equipment
Operator Station
Controller Console

NOTE:

See PROGRAM LOAD section for procedures.

A diagram illustrating this sequence is found on the following page.

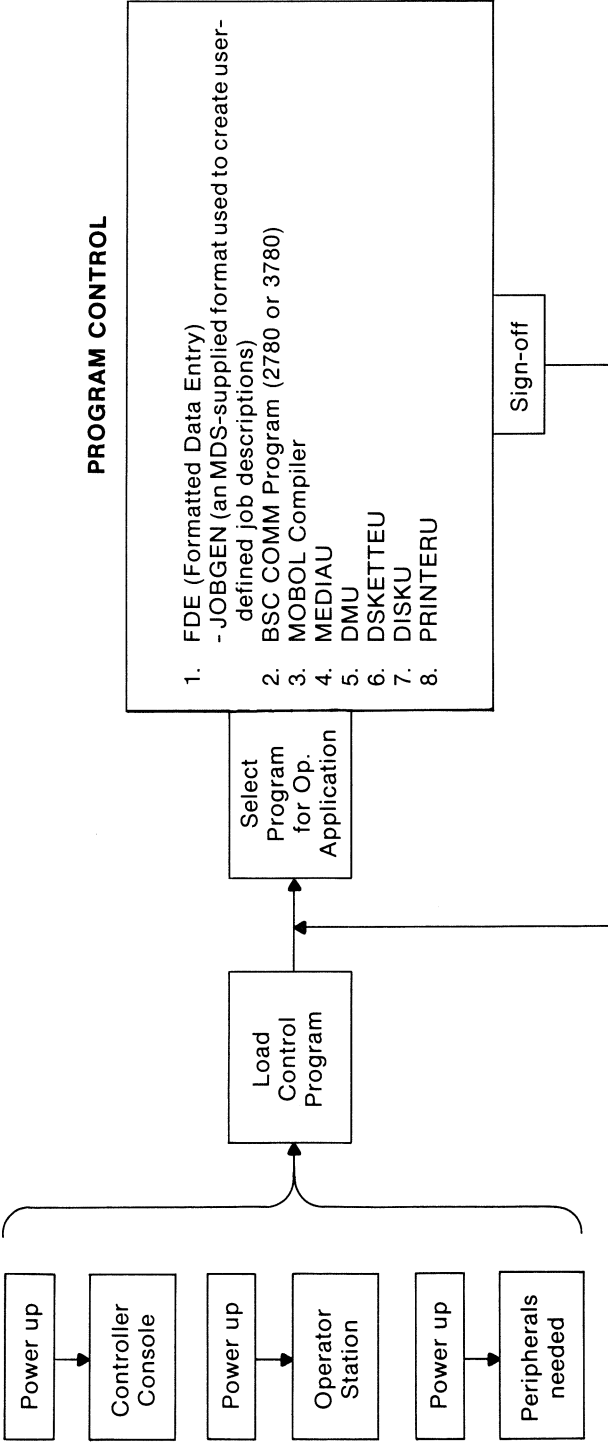

OPERATOR STATION — KEYBOARD

Three standard United States keyboards are illustrated on the following pages:

- Typewriter Style Keyboard
- Data Entry Style Keyboard
- Alternate Data Entry Style Keyboard

The use of the function keys and optional numeric pad are defined by the program loaded into the system.

FEATURES

Color-Coded Keys

FUNCTION KEYS (Dark Brown) — Enable various system functions to be initiated. Use of the keys is under program control, and description of key functions are provided, where appropriate, in the sections describing programs.

DATA KEYS (Light Brown) — Enable entry of alphabetic, symbolic/punctuation characters and, on the Typewriter Style Keyboard, numeric data.

NUMERIC KEYS (Ivory) — Found on both Data Entry Style keyboards. Enable entry of numerals 0-9 through use of the Numeric Shift Key. (Various alphabetic and function data keys share keytops with numerals.)

Numeric keys that do not require use of Numeric Shift Key are found on the optional numeric pad.

Key-Click and Audible Tones

Series 21 systems use electronic keyboards, which require minimum effort for each key depression. Operation of the keyboard is extremely quiet. The system creates an electronic "click" with each key depression. The loudness of the click can be adjusted by the volume control on the front of the display screen. The volume control also regulates the loudness of the tone that signals certain error/status conditions. The keyboard error indicator light and the tone are activated to signal error/status conditions requiring operator attention.

TYPEWRITER STYLE KEYBOARD

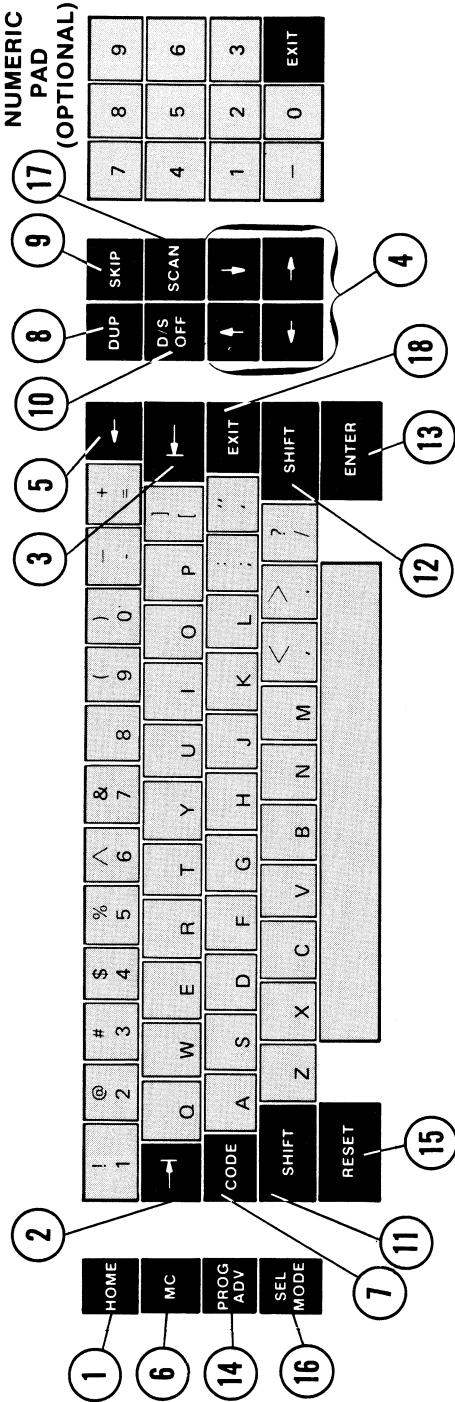

NAMES OF FUNCTION KEYS

- | | | | |
|---|-------------------------|--------|----------------------------|
| 1 | HOME | 10 | D/S OFF (Dup/Skip OFF) |
| 2 | → (Field Forward) | 11, 12 | SHIFT |
| 3 | ← (Field Backspace) | 13 | ENTER |
| 4 | ↕ (Cursor Control Keys) | 14 | PROG ADV (Program Advance) |
| 5 | ↔ (Character Backspace) | 15 | RESET |
| 6 | MC (Multi-Code) | 16 | SEL MODE (SELECT MODE) |
| 7 | CODE | 17 | SCAN |
| 8 | DUP (Duplicate) | 18 | EXIT |
| 9 | SKIP | | |

DATA ENTRY STYLE KEYBOARD

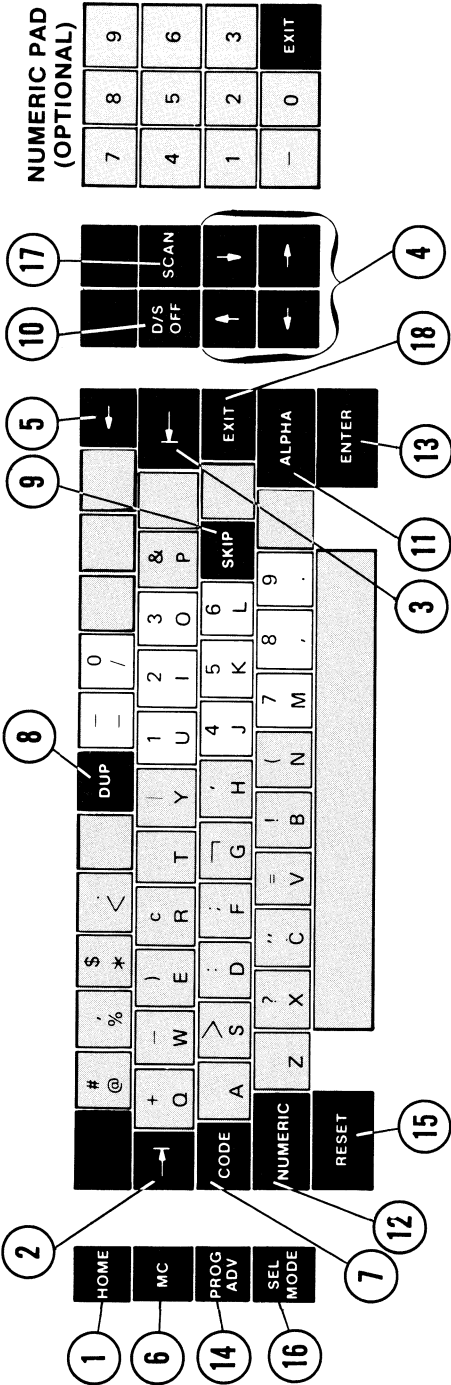

NAMES OF FUNCTION KEYS

- | | | | |
|---|-------------------------|----|----------------------------|
| 1 | HOME | 10 | D/S OFF (Dup/Skip OFF) |
| 2 | → (Field Forward) | 11 | ALPHA Shift Key |
| 3 | ← (Field Backspace) | 12 | NUMERIC Shift Key |
| 4 | ↕ (Cursor Control Keys) | 13 | ENTER |
| 5 | ← (Character Backspace) | 14 | PROG ADV (Program Advance) |
| 6 | MC (Multi-Code) | 15 | RESET |
| 7 | CODE | 16 | SEL MODE (Select Mode) |
| 8 | DUP (Duplicate) | 17 | SCAN |
| 9 | SKIP | 18 | ↕ (Cursor Control Keys) |

ALTERNATE DATA ENTRY STYLE KEYBOARD*

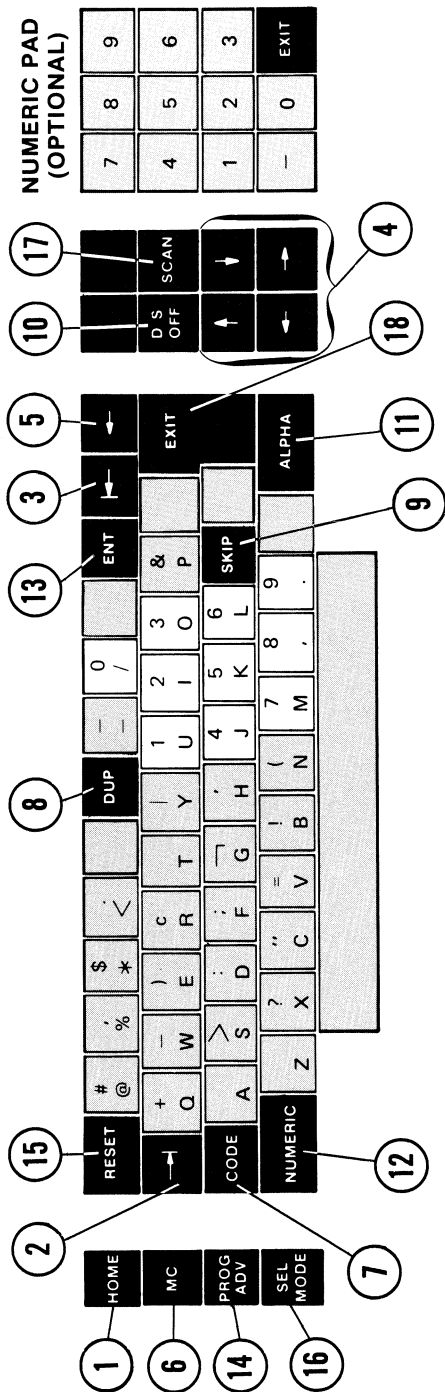

NOTE new locations of RESET, ENTER, EXIT, and ← (Field Backspace) keys.

NAMES OF FUNCTION KEYS

- | | | | |
|----|-------------------------|----|----------------------------|
| 1 | HOME | 11 | ALPHA Shift Key |
| 2 | → (Field Forward) | 12 | NUMERIC Shift Key |
| 3 | ← (Field Backspace) | 13 | ENTER |
| 4 | ↕ (Cursor Control Keys) | 14 | PROG ADV (Program Advance) |
| 5 | ← (Character Backspace) | 15 | RESET |
| 6 | MC (Multi-Code) | 16 | SEL MODE (Select Mode) |
| 7 | CODE | 17 | SCAN |
| 8 | DUP (Duplicate) | 18 | EXIT |
| 9 | SKIP | | |
| 10 | D/S OFF (Dup/Skip Off) | | |

* Feature No. 913 to the 2192 Operator Station

DISKETTE ORGANIZATION

This section describes the diskette storage device used by Series 21 systems, and the manner in which information is organized on diskette.

NOTE:

See INTRODUCTION for physical description of diskette, Tips and Precautions for handling diskettes, and procedures for inserting/removing diskettes.

Tracks and Sectors

The diskette is initialized in the Basic Data Exchange format before it is shipped to you. This means that a specific number of storage areas are assigned on the diskette as described below.

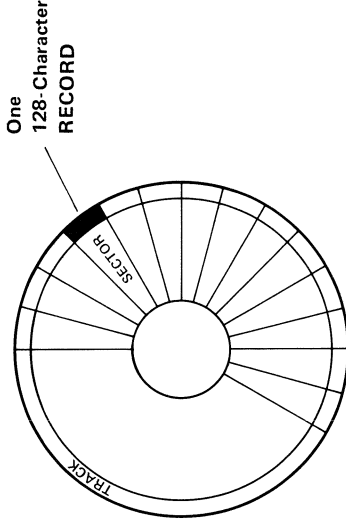
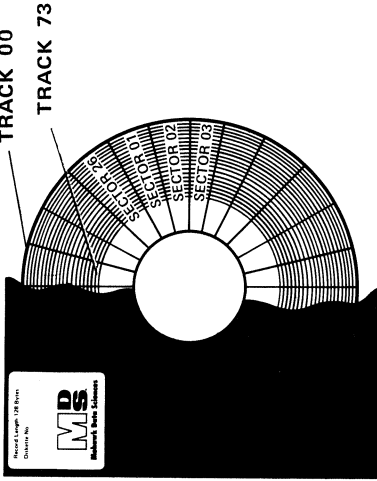

- 74 Circular TRACKS
- 26 Pie-Shaped SECTORS
- Track 00 is the Index Track
- Tracks 01 through 73 are Data Tracks
- One Record (up to 128 characters) can be stored in each Sector of each Track.

Usable data storage may thus be computed as follows:

73 Tracks x 26 Records/Track = 1898 Records.
 1898 x 128 characters = 242,944 characters per Diskette, excluding Index Track Records.

What Is A Dataset?

A dataset is a specific storage area on the diskette, made up of a number of sequential diskette sectors, residing on one or more diskette tracks. When using the system, information is recorded in or read from a dataset. Each dataset has a Dataset Name, Dataset Number (from 01-19), and an Allocation (the number of sectors comprising the dataset).

The accompanying illustration shows two datasets with the following allocations:

DATASET 01 = 35 Sectors
DATASET 02 = 147 Sectors

Index Track

Track 00 of each diskette is the *Index Track*. A portion of the Index Track contains the Volume Table of Contents (sometimes referred to as 'VTOC'). The Volume Table of Contents is like a book's table of contents; it contains information about the contents of the diskette. When a diskette is accessed by the system, the following VTOC information is read:

- VOLUME LABEL (one label per diskette): Includes the 6-character Volume ID (Name) of the diskette, and its specification regarding accessibility.
- DATASET LABELS (up to 19 per diskette): Each label includes the name and size of the storage area allocated to the dataset, plus other specifications and information about the dataset.

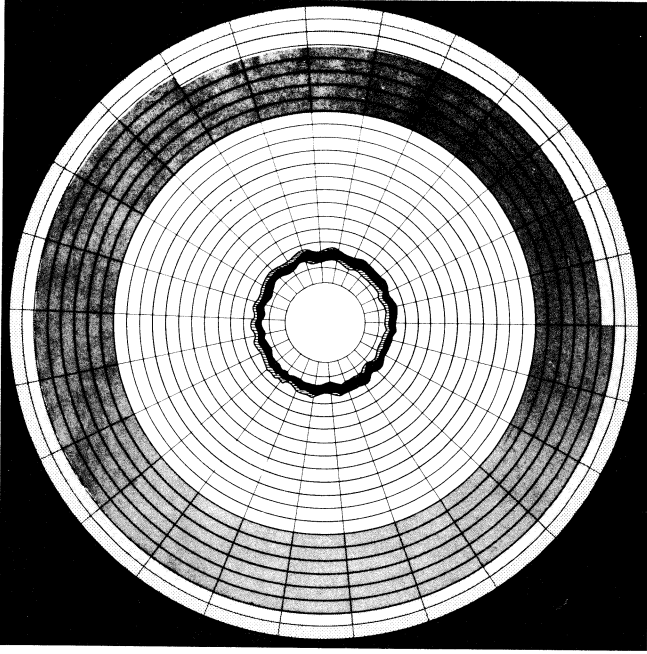

- Index Track (Containing the Volume Table of Contents)
- 1st Data Set
- 2nd Data Set
- Sectors currently not allocated into data sets

New Diskettes

Diskettes come from the vendor with a Volume ID and Dataset Labels already defined. Typically, the Volume ID will reflect the vendor's name, and the first dataset will describe the entire contents of the diskette. (All of the available 1898 sectors will be allocated to Dataset #1.)

If this is sufficient for the operation to be performed, there is no need to change the predefined labels. If changes are desired, the MDS-supplied program DSKETTEU may be used.

Volume Label

One Volume Label is written in the Index Track of each diskette. Here are some guidelines:

- The Volume ID may consist of 1-6 characters, including spaces.
- The Volume Label can be displayed and changed at any time using DSKETTEU or the utilities function of FDE.
- To "scratch" (prepare for reuse) a diskette that contains recorded data no longer needed, see procedures given in the DSKETTEU section.
- All Library Diskettes must have the letters "LIB" as the first three positions of the Volume Name. This enables the system to recognize the diskette as containing programs rather than data.

- Data Diskettes must not have "LIB" in the Volume Label. Otherwise, the system will attempt to load them as Library Diskettes.

Dataset Labels

Dataset Labels are written in the Index Track following the Volume Label. The information they contain consists of the specifications for each dataset.

Use procedures in DSKETTEU section to display, create or change Dataset Labels. The Utilities Function of FDE may also be used for this purpose.

Here are some guidelines:

- DATASET is a name consisting of 1-8 alphanumeric characters, excluding spaces. The first character must be alphabetic.
- DATASET # is the sequential number of the dataset, relative to other datasets on the diskette (01-19).
- ALLOC... OF and EOD are explained in Dataset Allocation, following.
- MULTI-VOL., LAST?, SEQ#, VERIFIED, CREATION and EXP fields are not accessed by Series 21. They are included to ensure compatibility with other equipment.

- A Yes (Y) specification in the DELETE field causes the dataset to be marked deleted. Deleted datasets retain their assigned storage area, unless deallocated.
- SECURITY and WRITE PROTECT fields may be used to read/write protect, or write protect the dataset.

Field	Key Entered	Translate To	Result
SECURITY	non-blank blank	as entered blank	Dataset secured (No read, no write) Dataset unsecured
WRITE PROTECT	non-blank blank	as entered blank	Dataset write-protected (Read allowed except when FDE is in control) Dataset unprotected

NOTE:

Record Size on diskette is normally set at 128. It must be set at 128 if the Job Description program level indicator is to be included on records entered into the dataset. Following data entry/verify operations, this field may be modified as required for purposes of IBM compatibility.

Dataset Allocation

To create one or more datasets of any size up to 1898 sectors, key the desired size in the ALLOC field. The following is an example of diskette allocation.

Dataset #	Alloc — Of	Sectors Left
1	500 of 1898	1398
2	1000 of 1398	398
3	300 of 398	98

If all the sectors were laid end to end, the above example would look like the example on the next page.

- RECORD SIZE as required for application (up to 128).

Allocation Addresses

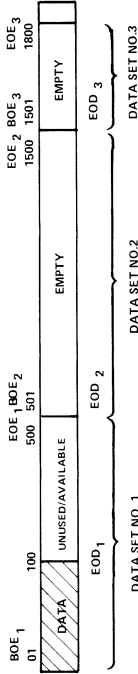

BOE = Beginning of Extent
 EOE = End of Extent
 EOD = End of Data

Here are some guidelines for assigning ALLOCATION and EOD values:

- ALLOC field must be greater than zero for the first dataset. Attempting to key 0's in this field results in a system error message "ALLOCATION ERROR".
- Following entry of a value in the ALLOC: field, the system automatically moves the remaining sectors to the next dataset, and displays this value in the OF field of that label.
- Attempting to allocate more than the available sectors for a dataset results in the "ALLOCATION TOO LARGE" message. This occurs if the operator attempts

to overlap contiguous dataset areas, or there are insufficient sectors left on diskette.

- If the allocation for a dataset is too small for the desired use, it may be expanded by first deallocating succeeding datasets to zero. The sectors deallocated may then be made available to the dataset requiring expansion.

NOTE:

Deallocation is not permitted if EOD > 000.

- EOD, or End of Data, is the number of the next sector in the dataset that is available for data. For new datasets, EOD is normally set to '000'. For existing datasets, keying 0's in the EOD field of the dataset label has the effect of "erasing" existing data, and enables the dataset to be re-recorded, beginning in the first record.

IMPORTANT

For FDE applications, EOD must initially be set to zero in order to create the deleted Control Record which is used for accumulators.

- Attempting to set an EOD value greater than the assigned allocation results in an "EOD ERROR" message.

PROGRAM LOAD

Program Load is the term for loading software into Series 21 memory, and is a necessary first step in any application or operation using Series 21.

Program Load procedures are the same for all Series 21 systems.

A single MDS Library Diskette ordinarily contains both the Control Program Data Set, which is used to initiate program control and enables the loading of Application Programs.

Programs for use with Series 21 systems are provided by MDS on Library Diskettes. The Volume Name of an MDS Library Diskette is always LIBxxx where xxx may be any combination of upper case letters. (Example: LIBSYS)

More than one Library Diskette may be required to accommodate the necessary Control and Application Programs. This exception is covered in the procedures which follow.

Initial Program Load

1. Power up Controller Console.
 - a. If POWER light/button on Console is illuminated, Power is already on. Proceed to Step 2.

- b. If POWER light/button is not illuminated, power up Console by pressing the POWER button. Then proceed to Step 2.
2. Power up Operator Station.
 - a. If red indicator light on the lower right front of Display Screen unit is illuminated, Operator Station power is already on. Proceed to Step 3.
 - b. If red indicator light is not illuminated, power up Operator Station by turning ON the ON-OFF switch on the lower left rear of the Display Screen unit.
 3. Insert MDS Library Diskette containing Control Program modules.
 - a. If diskette is the first to be inserted following Power Up for the day, the system automatically proceeds with loading Control Program.
 - b. If not, press RESET button on Controller Console, and loading proceeds.

- The messages 'LOADING', and 'INIT' appear, followed by the following display.

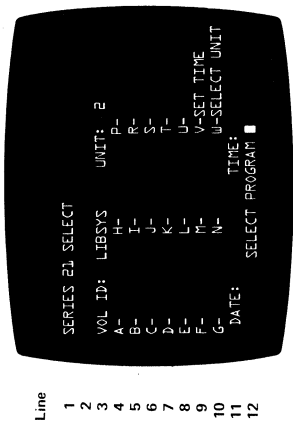

- The message 'PLEASE WAIT' remains until the system has read the Volume Table of Contents (VTOC) and fills the blank fields, as in the following example.

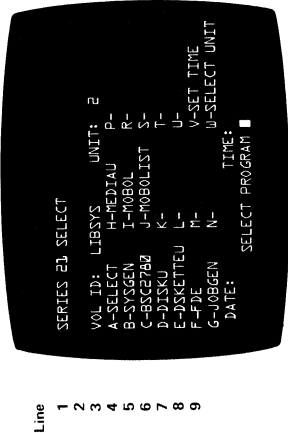

- If instructed to log in the date and time, proceed to Step 6. If not, go to Step 7.

- Select V-SET TIME by keying 'V'. The cursor is positioned in the six-character DATE: field, which is zero-filled.

- Enter numerals representing date, month, and year as in the following example:

ddmmyy = 031278 - 3 Dec 78

After keying the DATE: field or pressing the Field Forward key (→) once, the cursor is positioned in the TIME: field.

- Enter numerals representing hours, minutes and seconds, according to the instructions received, as in this example:

hhmmss = 011523 (1 hr, 15 min, 23 sec)

NOTE:

The TIME: field increments from zero with each INITIAL PROGRAM LOAD.

- c. The following Cursor Control keys may be used to change or correct keying errors:



Field Forward key advances cursor to next field.



Field Backspace key backs cursor to previous field.



Character Backspace key moves cursor back one character.



Skip key enables skipping to TIME: field. (TIME: field may not be skipped.)

- d. The numerals keyed will remain in the DATE: field; the TIME: field will continue incrementing during operation. The cursor will return to the SELECT PROGRAM field.

7. Select the desired Application Program by keying the letter preceding the program name (FDE, MEDIAU, etc.) as it appears on the display screen.

- a. If the desired program is present on the Library Diskette used for INITIAL PROGRAM LOAD, the system will proceed with loading the designated program after its letter is keyed. (It is not necessary to press ENTER.)

- The system ignores keystrokes other than the Alphabetic characters given in the menu-style display (A-M, P, and R-W).

- If a letter is keyed for which no dataset name is presented, the system searches for the dataset and then presents the message “#30”. The system then returns to the System Select Display so that selection of a valid program/dataset may proceed.

- b. If the desired program is *not* present on the Library Diskette used for INITIAL PROGRAM LOAD, another Library Diskette may be inserted in a second diskette drive. The selection procedure is as follows:

- Key ‘W’ for W-SELECT UNIT.
- Key the number of the diskette drive (1-4) into which the second Library Diskette has been inserted. Press ENTER. The system reads the VTOC of the designated diskette and replaces the previous “menu” with the names of the Application Programs/Datasets that may be selected.
- Key the letter preceding the program name (FDE, BSC 2780, etc.) as it appears on the display screen. The system proceeds with loading the designated program.

NOTE:

Both the Library Diskette used for INITIAL PROGRAM LOAD and the second Library Diskette must remain in the respective diskette drives until the initial display of the Application Program is presented. Then, both diskettes may be removed, if desired, to free the diskette drives for insertion of other diskettes.

8. A loaded Application Program remains in control of the system until SIGN OFF is selected from the Operating Mode Selection Display. Example:



9. When SIGN OFF is selected, the system searches for the Library Diskette containing the Control Program modules used for INITIAL PROGRAM LOAD.

a. If the Library Diskette has remained in the diskette drive, or has been reinserted, the system returns to the initial Program Selection Display (as in Step 5, foregoing). If required, time incremented during operation of Application Program can be logged, and another program selected.

b. If the Library Diskette has not remained in the diskette drive, the system presents the message '#30'. The message may be acknowledged by pressing RESET, but will recur until the Library Diskette containing the Control Program modules is reinserted. Then, the Application Program is replaced in memory by the Control Program modules, enabling selection of another Application Program if desired.

CAUTION

If a power fluctuation occurs during operation of a Series 21 System, an AUTOMATIC SYSTEM RESET will occur. This will result in an automatic attempt to reload system software; if an *unexpected* "LOADING" message is presented, or a "CHECK #3" message is displayed during operation. See page 7 for recovery procedures.

Key '7' to select SIGN OFF. There is a 3-4 second delay before the System Select Display is presented.

ERROR/STATUS MESSAGES
during INITIAL PROGRAM LOAD

DISPLAYED MESSAGE	MEANING	ACTION
CHECK #1	Memory Parity error	<ol style="list-style-type: none"> 1. Retry by pressing system RESET button on Controller Console. 2. If message recurs, retry with diskette in a different diskette drive. Press RESET again. 3. If message persists, retry using different Library Diskette. Press RESET again. 4. If above retry efforts fail, call MDS representative.
CHECK #2	Test Pattern Verification error	Same as for CHECK #1.
CHECK #3 (See also page 7)	<ol style="list-style-type: none"> 1. No diskette, or 2. Diskette improperly inserted in drive, or 3. Access door of diskette drive open. 	Remove diskette and re-insert it in diskette drive, being certain that label is facing toward right. Close access doors securely. Press RESET button on Controller Console.

ERROR/STATUS MESSAGES
during INITIAL PROGRAM LOAD, continued

DISPLAYED MESSAGE	MEANING	ACTION
CHECK #4	Diskette drive status error, possibly caused by attempt to remove Library Diskette during IPL.	Ensure that diskette is properly inserted; retry by pressing RESET button on Controller Console. If message recurs, insert the System Confidence Test diskette in a different diskette drive (see CONFIDENCE TEST section). Report findings to MDS Representative.
PHASE #1	Diskette in diskette drive does not contain Control Modules needed for loading, or is not a Library Diskette.	Insert Library Diskette containing Control Modules necessary for loading. Retry.
#30	(May occur following use of Application Program when SIGN OFF is selected.) Library Diskette used for IPL not resident in diskette drive.	Return Library Diskette used for IPL to a diskette drive; press RESET key on keyboard to acknowledge message. System will locate Library Diskette and return initial Program Selection Display.

**IN CASE OF POWER FLUCTUATIONS
DURING SERIES 21 OPERATION**

DISPLAYED MESSAGE	MEANING	ACTION
CHECK #3	<p>Power fluctuation caused an Automatic System Reset, and system has attempted to load a data diskette without a Library Diskette resident.</p> <p style="text-align: center;">NOTE:</p> <p>If FDE was originally in use when Automatic System Reset occurred, use the Utility Function to set the EOD indicator to the record <i>previous to the point at which operation was interrupted.</i></p>	<ol style="list-style-type: none"> 1. System software must be reloaded. Insert a Library Diskette. 2. The word LOADING should appear on the screen; if not, press RESET on the Controller Console. 3. Re-select desired program and proceed as when program was originally selected. 4. Establish a restart point and resume operation. (See Note).
LOADING	<p>If unexpected, an Automatic System Reset was initiated by the system. This may occur as a result of a power fluctuation.</p>	<ol style="list-style-type: none"> 1. System software is automatically reloaded by the system. 2. Re-select desired program and proceed as when program was initially selected. 3. Establish a restart point and resume operation. (See Note).



FORMATTED DATA ENTRY

The MDS Formatted Data Entry Program (FDE) provides a number of functions that are used to:

- record information in a diskette data set;
- verify information recorded on diskette data set;
- locate previously-recorded information on diskette data set; and
- make corrections and changes to information recorded on diskette data set.

Also provided in the FDE program is a UTILITIES function, used to create and modify diskette Volume and Data Set Labels. Alternately, the MDS-supplied Diskette Utilities Program (DSKETTEU) may be used for diskette labeling prior to use of FDE. (See DSKETTEU section of this publication.)

The FDE Program is supplied by MDS on a Library Diskette. It is loaded into a Series 21 System using procedures found in the PROGRAM LOAD section of this publication. This section describes how the Series 21 is used when FDE is loaded.

NOTE:

All Status/Error Messages documented in the *Series 21 Display Messages Manual for release 7.0 (M-3925)*.

The following subsections are provided:

Title	Page
INTRODUCTION	3
JOB LOAD	7
ENTRY	9
VERIFY	15
SEARCH	25
UPDATE	29
UTILITIES	31
STATISTICS	35
JOB DESCRIPTION	37
Introduction	37
Coding a Job Description	38
How to Enter a Job Description	47
TABLE V-1, Summary of Function Keys in ENTRY and VERIFY Modes	50

INTRODUCTION

The Formatted Data Entry Program (FDE) provides three modes for producing data records on diskette:

- ENTRY mode, for initial keyboard entry;
- VERIFY mode, for checking records produced in ENTRY, and
- UPDATE mode, to make changes to previously written records.

The FDE Program also provides these operations:

- a SEARCH operation allows a previously written record to be located;
- UTILITIES operations are used to create or change the Volume Label and/or the Data Set Labels on a diskette, and
- a JOB LOAD operation is used to load a Job Description into the system.

NOTE:

FDE provides two ways to change existing data set records:

1. UPDATE mode, where a record is located via SEARCH or by using CODE/SCAN keys to page backwards from EOD in ENTRY mode. Once positioned at the correct record, the contents of any field may be changed.
- If there are changes, the record is rewritten to the dataset when the record is released, and the next sequential record is read and displayed.
 - If there are no changes, the record is not rewritten when the record is released, and the next sequential record is read and displayed.

2. UPDATE/VERIFY mode, where a record is located via SEARCH or by using CODE/SCAN keys to page backwards from VEOD in VERIFY mode. Once positioned at the correct record, the contents of any field may be changed.
 - If there are changes, the record is re-presented on the screen for verification in VERIFY mode when the record is released. After verification of the record, it is rewritten to the dataset and the next sequential record is read and displayed.
 - If there are no changes, the record does not require verification and is not rewritten when the record is released.

MODE/OPERATION SELECTION

When FDE is loaded into the system, the Function Selection Display is presented on the display screen. Modes and operations can only be selected when the Function Selection Display is displayed. Selections are made by pressing the keyboard key having the same number as the desired Mode or Operation.

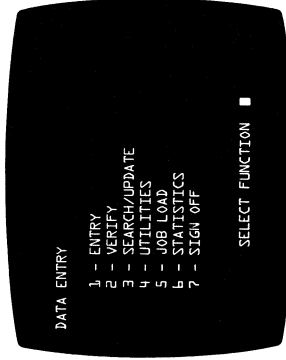

FDE Function Selection Display

IMPORTANT

Before a particular Mode or Operation (like ENTRY) is selected, it is often required to "set up" the system. Set-up sequences for ENTRY, VERIFY and SEARCH follow.

Set-Up Sequence For ENTRY

1. Load FDE from the Library Diskette. (See PROGRAM LOAD section of this publication.)
2. If a diskette data set is available for storing records, go to Step 3. If a diskette data set must be allocated for storing records, refer to UTILITIES in this section.
3. If a Job Description is already coded for this ENTRY job, go to Step 4. If a Job Description is not coded for this job, refer to JOB DESCRIPTION in this section.
4. If a Job Description is already loaded, go to Step 5. Otherwise, load the correct Job Description (refer to JOB LOAD in this section).
5. Begin the ENTRY operation (refer to ENTRY in this section).

Set-Up Sequence For VERIFY

1. If it is not already loaded, load FDE from the Library Diskette. (See PROGRAM LOAD section of this publication.)
2. If it is not already loaded, load the Job Description for this job. (Refer to JOB LOAD in this section.)
3. Begin the VERIFY operation (refer to VERIFY in this section).

Set-Up Sequence For SEARCH/UPDATE

1. If it is not already loaded, load FDE from the Library Diskette. (See PROGRAM LOAD section of this publication.)
2. If it is not already loaded, load the Job Description that was used to create the records to be located via SEARCH (refer to JOB LOAD in this section).
3. Begin the SEARCH operation (refer to SEARCH in this section). Note that a subsection entitled UPDATE follows the SEARCH subsection.

NOTE:

All modes must be exited by pressing SEL MODE to ensure that control records (such as EOD, VEOD) are updated.

JOB LOAD

BEFORE YOU BEGIN:

- **Controller Console POWER** must be **On**.
 - **Operator Station Power** must be **ON**.
 - **Is FDE loaded?** If not, see **PROGRAM LOAD** section.
1. If the FDE Function Selection Display is present, go to Step 2. If not, press **SEL MODE**.

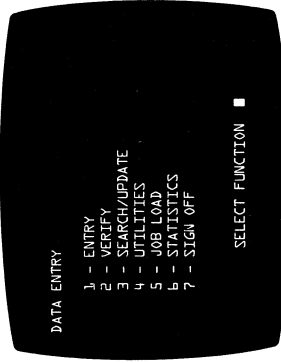

FDE Function Selection Display

2. Insert the diskette containing the desired Job Description dataset.
3. Press '5' to select **JOB LOAD**. The diskette **VTOC** is read, and the **Data Set Selection Display** is presented.



FDE Data Set Selection Display

4. The program fills the display with information from the diskette accessed, including **UNIT** number, **VOL ID** name, **DATASET** name of **DATA SET NUMBER 01**, **ALLOCATION** and **END OF DATA** for that data set.
5. Check the displayed **VOL ID** to ensure that the correct diskette is accessed.
If not, press **HOME** to move the cursor to the **UNIT:** field. Key the number (1-4) of the diskette drive which contains the **Job Description** to be used.
Press **ENTER**. The program will display details about the diskette in the **UNIT** specified.

6. If the displayed Data Set Name is correct, press ENTER. If not, the following actions are available:
 - a. To advance to the next data set, press the SCAN key; to backspace to previous data set, hold CODE key down and press SCAN. Once the desired Data Set Name is displayed, press ENTER to accept the data set.
 - b. To locate a specified data set by its Data Set Name, press Field Backspace key (←) to move the cursor to the DATA SET: field. Key the desired Data Set Name. If the name is less than 8 characters, press SKIP to complete the field. Then, press ENTER to accept the data set.

NOTE:

The message 'JOB SEQUENCE ERROR' may be received if the dataset selected does not contain a valid Job Description. Acknowledge the message by pressing the RESET key, then press SEL MODE. Reselect JOB LOAD from the Function Selection Display and locate the valid Job Description dataset.

7. When the JOB LOAD operation is complete, the FDE function Selection Display is returned. Another Mode or Operation may be selected.

NOTE:

For information about creating a Job Description, see JOB DESCRIPTION in this section.

ENTRY

BEFORE YOU BEGIN:

- **Controller Console POWER must be On.**
- **Operator Station Power must be ON.**
- **Is FDE loaded? If not, see PROGRAM LOAD section of this publication.**
- **Is a data set available for data? If not, see UTILITIES in this section.**
- **Is the Job Description loaded? If not, see JOB LOAD in this section.**

1. If the FDE Function Selection Display is displayed, go to Step 2. If not, press SEL MODE.



FDE Function Selection Display

2. Insert the diskette that will be used to store data. (The Library Diskette may be removed at this time.)
3. Press '1' to select ENTRY. The diskette is read, and the Data Set Selection Display is presented.

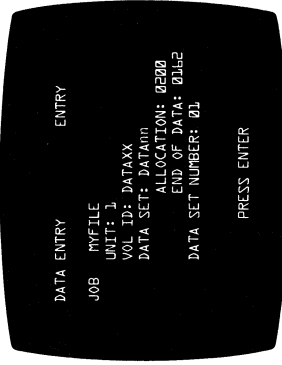

FDE Data Set Selection Display

4. Check the displayed Volume ID to ensure that the correct diskette is accessed.

NOTE:

If it is required to change the UNIT number in order to access a different diskette, press HOME to position cursor in UNIT: field. Key desired unit number (1-4) and press ENTER.

Notice the following Data Set Label information contained on the display:

DATASET:

Field presents the name of Data Set #01, currently accessed.

ALLOCATION:

Field presents the number of sectors allocated to this data set.

END OF DATA:

Field presents the number of the next unused record in this data set.

DATA SET NUMBER:

Field presents the number of this data set on the diskette accessed.

5. If the displayed Data Set Name is the correct one, press ENTER and go to Step 6.

If not, the following actions are available:

- a. To advance to next data set, press the SCAN key: to backspace to the previous data set, hold CODE key down and press SCAN. Once the desired Data Set Name is displayed, press ENTER to accept the data set.
- b. To locate a specified data set by its Data Set Name, press Field Backspace key (), then key the desired name. If the Data Set Name keyed is less than 8 characters, press SKIP. Then, press ENTER to accept the data set.
6. After successfully locating the data set, FDE blanks the screen, then presents the production status information on lines 1 and 2 of the display and displays the prompts from the first level of the selected Job Description.

Figure V-1. Annotated Production Display

During ENTRY mode, the Production Display remains on Display Screen lines one and two, providing the following information:

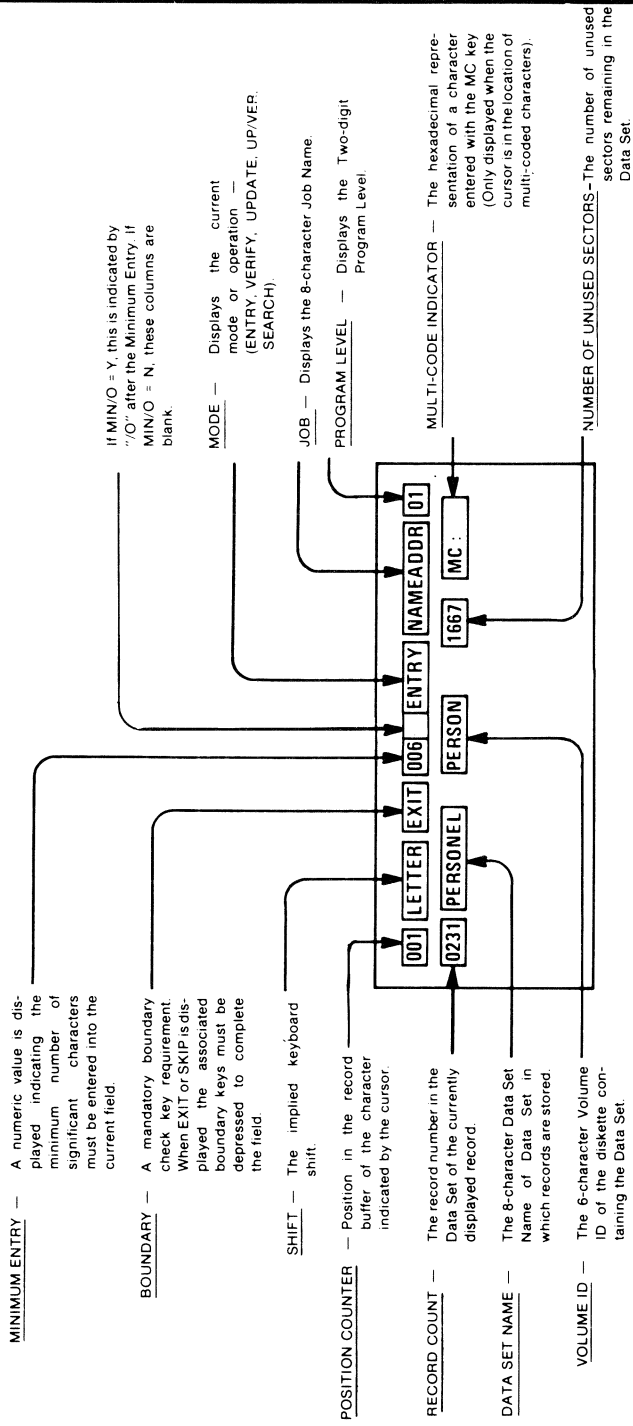

Note the following:

- All fields are initially blank-filled, and the cursor is positioned at the first data field.
 - If the dataset has EOD = 0, meaning that no data has been collected to it, FDE writes one deleted record at position 0, updating the EOD to 001. This deleted record, called the "control record", is used to store accumulator information and VEOD when production is complete.
 - Prompting messages are displayed at normal brightness on the screen; information being entered is displayed more brightly.
7. Key data in fields contained in the Job Description, as presented on the display. If AUTO RELEASE is specified in the Job Description, the record is automatically written to EOD when the last field of a record has been completed. If manual release (AUTO RELEASE = N), the ENTER key must be pressed before FDE will write the record to EOD.

8. When entry of Job is complete, or at any point during use of ENTRY mode, pressing SEL MODE returns the FDE Function Select Display.

Using AUTOMATIC FIELDS:

- a. NEW START (first record keyed after selecting ENTRY mode)

DUP fields: The cursor automatically stops at the first occurrence of each DUP field when entering the first program level. Thereafter, the information is automatically duplicated from the previous record into every program level.

AUX/DUP fields: The cursor automatically stops at the first occurrence of an AUX/DUP field in each program level. Thereafter the information is automatically duplicated from the AUX-DUP buffers. Pressing SEL MODE clears the buffers.

b. SUBSEQUENT RECORDS

DUP fields: DUP information is automatically entered.

AUX/DUP fields: Same as AUX/DUP fields above.

CORRECTING ERRORS DURING ENTRY

Two types of errors may occur while keying in ENTRY mode: Operator-detected errors, and Program-detected errors.

Operator-Detected Errors

Use the following recovery procedures for single character or single field correction prior to record release to diskette (before ENTER is pressed.)

EXAMPLE: 'HONES' is keyed instead of 'JONES'
'132' is keyed instead of '123'

Press Field Backspace key () to move cursor back to the beginning of the field requiring correction. Re-key the field.

OR

Press Character Backspace () to move cursor back one position at a time until incorrect character is reached. Re-key the correct character.

OR

Press HOME key to move cursor back to the beginning of the first manual field on the record displayed, then press Field Forward key () to position cursor at field with error. Re-key as needed.

To correct keying errors on records already released to diskette, hold the CODE key down and press SCAN to display the previous record. This initiates UPDATE mode. Refer to UPDATE subsection for procedures.

Program Detected Errors

Program-detected operator errors are caused by attempting to enter information other than that allowed by the current Job Description.

When an error occurs, the error tone sounds and the message 'KEYING ERROR' is displayed on line 2 of the Production Display. The keyboard will not accept further information until the RESET key is pressed to acknowledge the message.

After pressing RESET, correct the keying error and resume ENTRY operation.

Error messages other than 'KEYING ERROR' may be displayed. Refer to MDS publication *Series 21 Display Messages Manual (M-3925)* for details.

SPECIAL FUNCTIONS

To Display Accumulators

1. Press HOME key to position cursor at the beginning of the first manual field of the record displayed.
2. Hold the CODE key down and press HOME. The following display is presented, showing current totals on Accumulators.

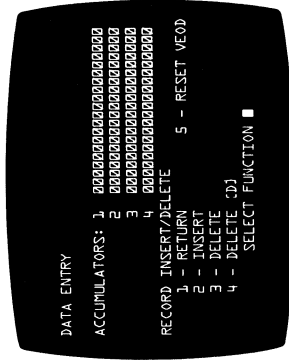

FDE Accumulators Display

3. To return to ENTRY mode, press '1'.

NOTE:

Records cannot be inserted or deleted in ENTRY mode; press CODE/SCAN to back up, initiate UPDATE function in order to perform insertion or deletion operations.

VERIFY

BEFORE YOU BEGIN:

- **Controller Console POWER must be On.**
- **Operator Station Power must be ON.**
- **Is FDE loaded? If not, see PROGRAM LOAD section.**
- **Is the correct Job Description loaded? If not, see JOB LOAD in this section.**

1. The FDE Function Selection Display must be present. If not, press SEL MODE.

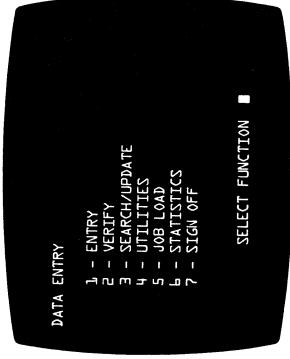

FDE Function Selection Display

2. Insert the diskette that contains the unverified records. (The Library Diskette may be removed at this time.)

3. Press '2' to select VERIFY mode. The diskette is read and the Data Set Selection Display is presented.



FDE Data Set Selection Display

4. Check the displayed Volume ID to ensure that the correct diskette is accessed.

NOTE:

If it is required to change the UNIT number in order to access a different diskette, press HOME to position cursor in UNIT: field. Key desired unit number (1-4) and press ENTER.

Verify, continued

Notice the following Data Set Label information contained on the display:

DATASET:

Field presents the name of Data Set No. 1, currently accessed.

ALLOCATION:

Field presents the number of sectors allocated to this data set.

END OF DATA:

Field presents the number of the next unused record in the dataset.

DATA SET NUMBER:

Field presents number of this data set on the diskette accessed.

FORMATTED DATA ENTRY — 16

5. If the displayed Data Set Name is the correct one, press ENTER and go to Step 6.

If not, the following actions are available:

- a. To advance to next data set, press SCAN key; to backspace to the previous data set, hold CODE key down and press SCAN. Once the desired Data Set Name is displayed, press ENTER to accept the data set.
 - b. To locate a specified data set by its Data Set Name, press Field Backspace key (**←**), then key desired name. If the Data Set Name keyed is less than 8 characters, press SKIP. Then press ENTER to accept the data set.
6. After successfully locating the dataset, FDE blanks the screen, then presents the production status information on lines 1 and 2 of the display, and displays the prompts from the first level of the selected Job Description.

Figure V-2 Annotated Production Display

During VERIFY mode, the Production Display remains on Display Screen lines one and two, providing the following information:

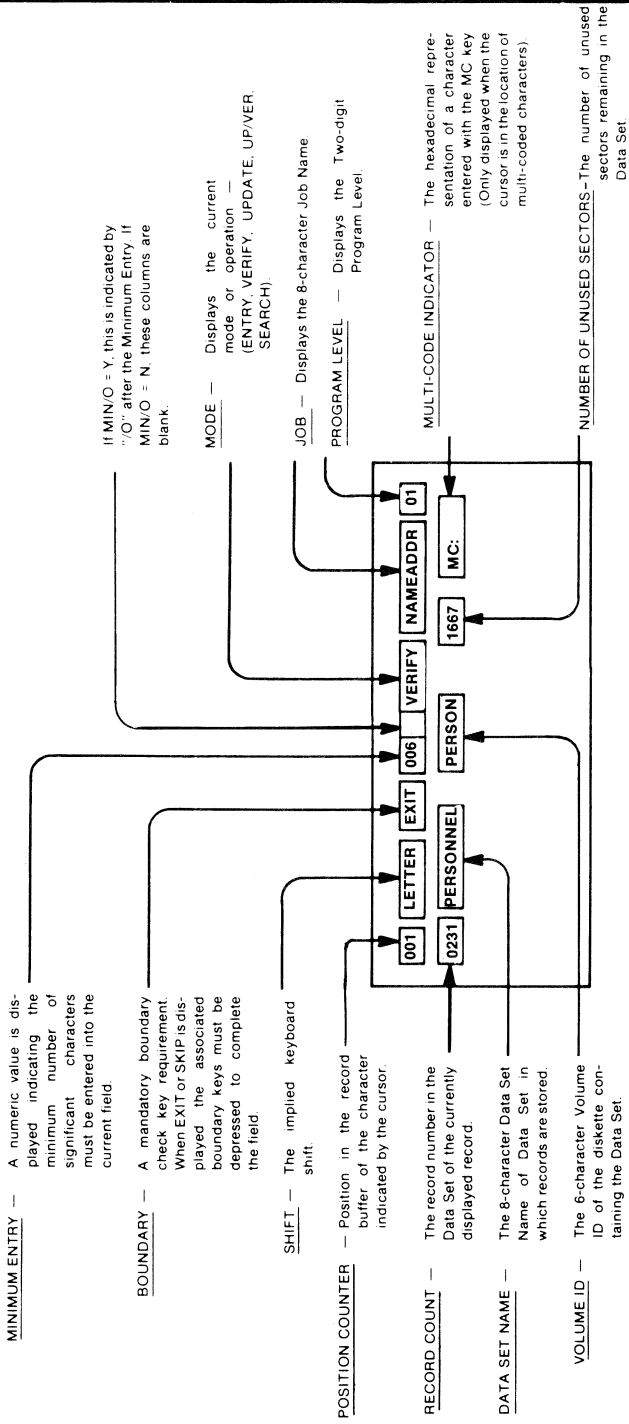

Step 6, continued

Note the following:

- Verification begins at VEOD, the first unverified record in the dataset. FDE maintains a pointer to this record in the control record (record 0) of the dataset.
 - The cursor is positioned in the first position of the first Verify field, as specified by the Job Description.
 - Prompting messages are displayed at normal brightness on the screen; information being keyed during verification is displayed more brightly.
 - Depression of the first data key causes all verify fields to be suppressed from the display.
 - Verification errors (mismatches) cause these verify fields to reappear until verification resumes.
7. When verification is complete, or at any point during use of VERIFY mode, pressing SEL MODE returns the FDE Function Select Display. The VEOD pointer is updated to the value of the last record verified.

About AUTOMATIC FIELDS

- a. Verification of AUTOMATIC FIELDS (if an automatic field is marked as a verify field in the Job Description):

DUP fields:

The cursor stops at the first occurrence of each DUP field for verifying duplicate information. After verification of the first program level is complete, DUP information is automatically verified.

AUX/DUP fields:

The cursor stops at the first occurrence of each AUX/DUP field in each program level for verifying AUX/DUP information. Once each AUX/DUP field in each program level is verified, AUX/DUP fields are automatically verified.

- b. Fields defined as non-VERIFY by the Job Description are automatically bypassed as they are encountered.

CORRECTING ERRORS DURING VERIFY

If a character keyed in VERIFY mode is different than the same character in the same position recorded in ENTRY mode, the following occurs:

- The message 'MISCOMPARE' is displayed;
- The error light and error tone are activated;
- The entire contents of the record remain displayed;
- The keyboard will not accept further entries until the RESET key is pressed;
- The cursor remains in the position at which the error occurred.

To Correct A Single Character

1. Press RESET key.
2. Re-key the character. If the character agrees with either the character recorded in ENTRY or the character just keyed, it is accepted.
3. If the message 'MISCOMPARE' recurs, press Character Backspace key (←). The cursor remains in the error position, and the position is blanked.
4. Key the correct character. The cursor remains in the error position and the position is blanked.

5. Key the character again to verify.
6. Continue normal verification.

To Correct A Field

1. Press RESET key.
2. Press Field Backspace key (⇐) twice. The cursor moves to the first position of the field.
3. Key the entire field. The cursor then returns to the first position of the field, and the field is blanked.
4. Key the field again to verify.
5. Continue normal verification.

To Correct A Record Already Released To Diskette:

1. CODE/SCAN to the desired record; this causes UPDATE /VERIFY mode to be initiated. Change all, several, or one of the fields of a given record. When cursor is at record end, status line changes to VERIFY.

Key-verify the entire record (including DUP and AUX/DUP fields but excluding non-verify fields).

OR

2. Corrections may be made via the UPDATE/VERIFY option of SEARCH MODE. Inserts and deletes can be made in VERIFY mode or SEARCH/UPDATE. (See Special Functions, following, for details.)

SPECIAL FUNCTIONS

To Display Accumulators

1. With the cursor in "Home" position of the record, hold the CODE key down and press HOME. The following display is presented, showing current accumulator totals.

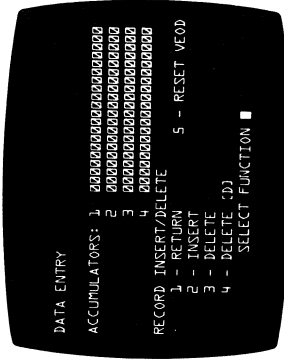

FDE Accumulators Display

2. Press '1' to return to VERIFY mode.

To Insert One Or More Records

1. With the cursor in the "Home" position of the record, hold CODE key down and press HOME. The display shown above is presented.

2. Press '2'. The following display is presented.

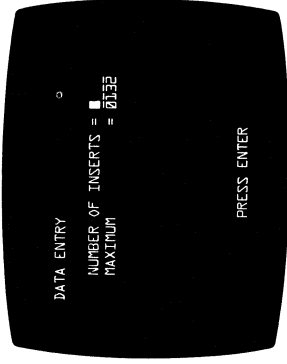

3. Key the number of records to be inserted. The maximum number that can be inserted is provided by the program in the MAXIMUM: field. Press ENTER.

NOTE:

The only way to return the active mode is to key a value of '0000'.

4. The message 'PLEASE WAIT' appears on the display while the program prepares for insert. This may take several minutes.

- The active mode is returned to the first new inserted record (which is marked deleted). A 'DELETED RECORD' message is accompanied by the error indicator light and tone. Acknowledge message by pressing the RESET key.

NOTE:

Inserted records are marked as deleted so that they will not be included as part of the keyed data until they are actually keyed.

- Key the record to be inserted.

When the last record to be inserted has been keyed, the next unverified record is returned, and normal verification may continue.

CAUTION

Data can be "lost" if the dataset diskette is removed prior to exiting VERIFY mode by pressing SEL MODE.

To Delete A Record

- To delete the currently displayed record, ensure that cursor is in the "Home" position of the record. Hold CODE key down and press HOME. The FDE Accumulators Display is presented.

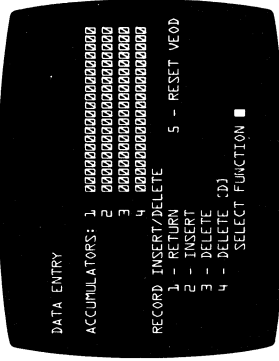

FDE Accumulators Display

- Perform one of the two following actions:
 - For NON-IBM COMPATIBLE format — press '3'. The system returns to VERIFY mode and the next record to be verified.
 - OR
 - For IBM-COMPATIBLE format — press '4'. The system returns to VERIFY mode and the next record to be verified.

To Reset The VEOD Pointer:

1. With the cursor in the "Home" position of the record, hold the CODE key down and press HOME. The following display is presented:

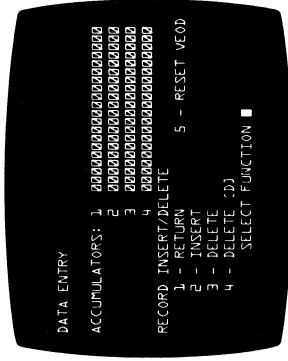

FDE Accumulators Display

2. Press '5' to reposition the VEOD (Verified End of Data) pointer to the first record of the file: this re-initiates verification of the entire file.

SEARCH

BEFORE YOU BEGIN:

- Controller Console POWER must be ON.
- Operator Station Power must be ON.
- Is FDE loaded? If not, see PROGRAM LOAD section.
- Is the correct Job Description loaded? If not, see JOB LOAD in this section.

1. The FDE Function Selection Display must be present. If not, press SEL MODE.



FDE Function Selection Display

2. Insert the diskette containing the data set to be searched. (The Library Diskette may be removed at this time.)

3. Press '3' to select SEARCH/UPDATE. The diskette is read, and the Data Set Selection Display is presented.

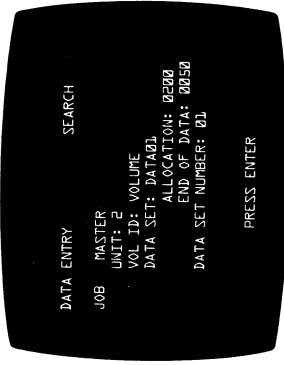

FDE Data Set Selection Display

4. Check the displayed Volume ID to ensure that the correct diskette is accessed.

NOTE:

If it is required to change the UNIT number in order to access a different diskette, press HOME to position cursor in UNIT: field. Key desired unit number (1-4) and press ENTER.

Search, continued

Notice the following Data Set Label information contained on the display:

DATA SET: Field presents the name of Data Set #01, currently accessed.

ALLOCATION: Field presents the number of sectors allocated to this data set.

END OF DATA: Field presents the number of the next unused sector in this data set.

DATA SET NUMBER: Field presents number of this data set on the diskette accessed.

5. If the displayed Data Set Name is the correct one, press ENTER and go to Step 6.

If not, the following actions are available:

a. To advance to the next data set, press SCAN key; to backspace to the previous data sets, hold CODE down and press SCAN. Once the desired Data Set Name is displayed, press ENTER to accept the data set.

FORMATTED DATA ENTRY — 26

b. To locate a specified data set by its Data Set Name, press Field Backspace key (\leftarrow), then key desired name. If the Data Set Name keyed is less than 8 characters, press SKIP. Then press ENTER to accept the data set.

6. When the designated data set has been located, the program presents the SEARCH Function Selection Display.

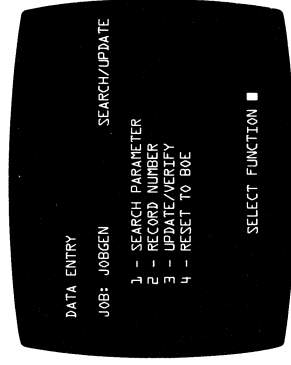

7. The currently loaded Job Description is displayed in the JOB: field. Four SEARCH function selections are offered:

Key '1' to perform a search using a Search Identifier; go to Step 8.

Key '2' to perform a search beginning at a specific record number; go to Step 9.

Key '3' to set a flag so that further processing via a SEARCH mode of FDE is in the UPDATE/VERIFY mode. In this mode, all updates require verification. An asterisk (*) precedes the number 3 on this display when this function is active. To de-activate the function, press '3' again. Then press '1', '2' or '4' to proceed with the SEARCH operation.

Key '4' to begin search at the first record in the selected data set (at BOE); go to Step 10.

8. The Production Display is presented at Program Level 01. Enter the Search Identifier. The \rightarrow or \rightarrow keys may be used to bypass non-applicable character or field positions. The PROG ADV key may be used to change levels.

NOTE:

The data set can only be forward searched.

Press ENTER to initiate the search; go to Step 10.

9. When '2' has been selected from the SEARCH Function Select Display, the following display is presented:

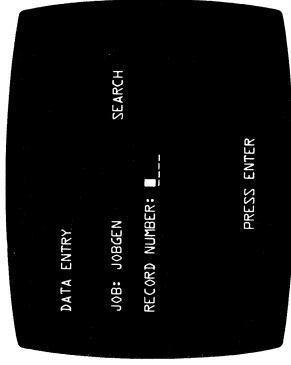

Key the number of the record at which SEARCH is to begin. Press ENTER to initiate the search; go to Step 10.

NOTE:

If the record is not located, the message 'NOT FOUND' is presented. Press RESET to acknowledge. The program returns the SEARCH Function Selection Display to enable another selection.

10. When the record is located via SEARCH function selected, the following occur:
 - The record is displayed, and
 - The system is automatically conditioned for UPDATE mode.

11. The following options are available at this time:
- a. If selection at Step 7 was '1 — SEARCHPARAM', the search may be continued by holding the CODE key down and pressing the Field Forward key (**→**).
 - b. Press the SCAN key to display the next record.
 - c. Hold the CODE key down and press the SCAN key to display the previous record.
 - d. Hold the CODE key down and press the HOME key to insert, delete, reset VEOD, or check accumulators.
 - e. Hold the CODE key down and press the ENTER key to return to the SEARCH Function Select Display. UPDATE/VERIFY function may be activated, if desired.
 - f. Make corrections to the current record, with verification of each changed record if UPDATE/VERIFY function is active.

NOTE:

Record 000 is a deleted record; this will be noted by an error message if it is displayed via SEARCH mode.

UPDATE

UPDATE mode is automatically initiated by any of the following operations:

- Pressing CODE/SCAN in ENTRY or VERIFY mode,
- Locating a record in SEARCH mode, or
- Choosing UPDATE/VERIFY function when in SEARCH mode.

UPDATE mode enables changes to records existing in the selected data set. Note the following:

- a. When UPDATE mode is initiated from ENTRY mode, ENTRY mode is automatically returned when EOD is reached.
- b. When UPDATE/VERIFY mode is initiated from VERIFY mode, VERIFY mode is automatically returned when either EOD or the last unverified record is reached.
- c. UPDATE/VERIFY is a special case of updating. Each record that is changed must also be verified (re-keyed) immediately.
- d. When UPDATE/VERIFY mode is activated from SEARCH mode, it remains in effect until de-selected (see procedure in SEARCH mode in this section).

To Make Corrections in UPDATE Mode:

1. Key required changes. The Field Forward (\longrightarrow) and Cursor Control keys are available for positioning the cursor.

NOTE:

It is not necessary to re-key fields that do not require change. Unchanged information on either side of the cursor is copied without change.

2. Once corrections are keyed, pressing ENTER rewrites the record on diskette (except during UPDATE/VERIFY where immediate verification of the changed data is required).

NOTE:

The ENTER key is not required if the last field in the program level is changed and Auto Release is specified for the program level in the Job Description.

UTILITIES

BEFORE YOU BEGIN:

- **Controller Console POWER must be On.**
- **Operator Station Power must be ON.**
- **Is FDE loaded? If not, see PROGRAM LOAD section.**

NOTE:

Exclusive use of Library Diskette volume is required to use the UTILITIES function of FDE.

1. The FDE Function Selection Display must be present. If not, press the SEL MODE key.

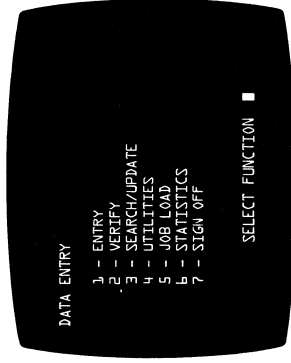

FDE Function Selection Display

2. Insert the diskette requiring volume or data set label modification. (The Library Diskette may be removed at this time.)
3. Press '4' to select UTILITIES. The UTILITIES Function Selection Display is presented.

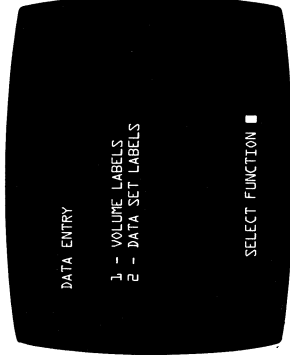

4. Select appropriate function as follows:
Key '1' to select VOLUME LABELS. Go to Step 5.
Key '2' to select DATA SET LABELS. Go to Step 8.

Utilities, continued

- When '1' is keyed, the Volume Label Display is presented.



- Key the number of the diskette drive (1-4) which should be accessed. Press ENTER. The program reads the Volume Label of the diskette accessed and displays the Volume ID and accessibility designation.

- The following operations may be performed:

- TO CREATE A "SCRATCH" DISKETTE, hold CODE key down and press HOME key. This prepares a previously used diskette for re-use.
- TO CHANGE VOLUME NAME, key new 6-character name in the VOL ID: field. If new name is less than 6 characters, the SKIP key may be pressed to complete the field. Press ENTER.

FORMATTED DATA ENTRY — 32

- TO CHANGE VOLUME ACCESSIBILITY, key as follows:

Key a space or press SKIP to blank the ACCESSIBLE: field if Volume is to be marked accessible.

Key any non-blank character in the ACCESSIBLE: field if Volume is to be marked inaccessible.

NOTE:

Pressing CODE/RESET prior to pressing ENTER restores original values to the display.

- When '2' has been keyed, the Data Set Label Display is presented.

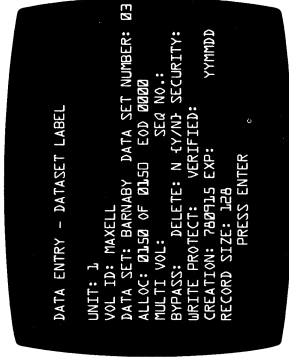

9. The cursor is positioned in the UNIT: field. Key the number of the diskette drive that contains the diskette requiring Data Set Label creation/modification. Press ENTER.

10. The Data Set Label for DATA SET #01 on the diskette accessed is read and displayed.

If the displayed Data Set Name/Number is the correct one, press ENTER. If not, press SCAN to advance to next Data Set, or CODE/SCAN to back up to the previous Data Set. When desired Data Set Label is displayed, press ENTER.

11. For detailed information about the fields on the Data Set Label Display, refer to Table X-1 in the DSKETTEU section of this publication.

NOTE:

A dataset label marked WRITE PROTECT: x, where x = any non-blank character, is treated by FDE as both read-protected and write-protected. Other Rel. 7.0 application programs treat such a label as write-protected only.

12. The following options are available:

- TO CREATE A NEW DATA SET LABEL, fill in required fields, allocating the number of sectors desired (may not exceed value shown in OF: field). When keying is complete, press ENTER.
- TO MODIFY EXISTING DATA SET LABEL, use Field Forward key (——▶) to position cursor to fields requiring modification. When all changes are keyed, press ENTER.
- TO DEALLOCATE A DATA SET, advance cursor to ALLOC: field using the Field Forward key (——▶). Key '0000'. Press ENTER.

NOTE:

Pressing CODE/RESET prior to pressing ENTER restores the original values to the display.

13. After ENTER is pressed, new or changed information is written to the Data Set Label, press SEL MODE to return the FDE Function Select Display.

STATISTICS

Each Operator Station maintains individual keystroke and record counters during operation of FDE. Each time FDE is loaded, the counters are automatically set to zero. The counters may also be reset to zero manually, if required.

To Display Current Statistics:

1. The FDE Function Selection Display must be present. If not, press SEL MODE.



FDE Function Selection Display

2. Key '6' to select STATISTICS. The Production Statistics Display is presented.



3. If desired, hold the CODE key down and press the RESET key to zero counters. Then press the ENTER key.
4. Otherwise, press the ENTER or SEL MODE keys to return to the FDE Function Selection Display.

DESCRIPTION OF COUNTERS

KEYSTROKES

Total keystrokes. When 999,999 is reached, counter restarts at 000,000.

KEY CORRECT

Total characters corrected during VERIFY mode, or modified during UPDATE mode. When 999,999 is reached, the counter restarts at 000,000.

RECORDS

Total records processed in ENTRY, VERIFY, and UPDATE modes. Record advances in UPDATE mode are not counted unless data is keyed and entered. Record advances in VERIFY mode are not counted if performed from the "Home" position of the record. When 99,999 is reached, the counter restarts at 00,000.

INSERTS

Total records inserted using the record insertion sequence via SEARCH mode.

DELETES

Total records deleted using the record deletion sequence via SEARCH/UPDATE or UPDATE/VERIFY modes.

NOTE:

No overflow condition is indicated when counters reach maximum count allowed.

JOB DESCRIPTION

A Job Description is a user-written format with specifications about the type of prompts and fields that will control entry, verification, or updating of data using FDE.

Besides FDE, MDS supplies a format called JOBGEN which enables writing user-defined Job Descriptions to diskette. Once written to a diskette data set, a Job Description may be reused as required.

How To Create A Job Description

Three main steps are involved in creating a Job Description:

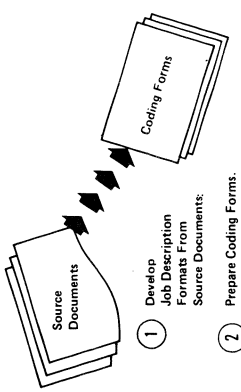
- ① Analyze the type of data to be entered,
 
- ②

- ② Determine the PROGRAM LEVELS, PROMPTS and FIELDS needed for each program level. Code this information on special MDS-supplied coding forms.

AND

- ③ Enter the Job Description on a diskette data set by loading FDE, specifying JOBGEN as the job, and using ENTRY mode of FDE.

This process may be visualized as shown in the following illustration:

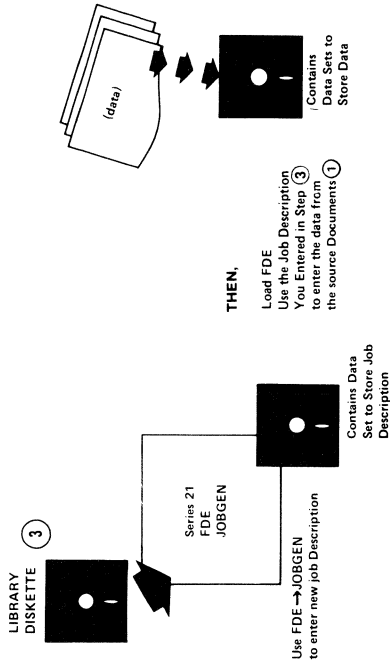

Once the Job Description is written to a diskette dataset, it is ready to be used by FDE to control use of the ENTRY, VERIFY, or UPDATE modes to perform a SEARCH operation with FDE.

Job Descriptions may be verified or updated with JOBGEN specified as the job, using FDE.

TERMS AND DEFINITIONS

CHARACTER Any single alphabetic or numeric character, or certain symbols (such as @, #, \$, %, etc.) used to enter data and occupying a single position in a field.

FIELD A group of related characters, (such as a name, address, part number, date, etc.) A field may consist of from 1-128 characters.

PROMPT A message designed to cue data entry operator as to the expected contents of a field or fields. Examples: DATE:, ORDER NO.:, SERIAL #, etc.

Prompts may also be titles, identifying the group of fields that make up a portion of the Job Description. Examples: RAW STOCK REQUISITIONS; SALES WEEK OF JAN. 1, etc.

PROGRAM LEVEL

A group of related fields organized into one screen display. A program level may consist of from 1-20 fields.

ATTRIBUTE BYTE

One byte reserved at the beginning of each PROMPT and each FIELD. The value of this byte is provided automatically by FDE.

Procedure For Coding A Job Description:

Step 1.

Identify the information that must be extracted from source documents. Organize the information in logical groupings, given the limitations stated in TERMS AND DEFINITIONS above regarding maximum length of fields, and number of fields that may constitute a program level.

Step 2.

Determine the PROMPTS needed and the types and sizes of FIELDS that must be created in order to enter the information.

Step 3.

Organize the FIELDS into PROGRAM LEVELS, grouping them according to the sequence the data will be encountered in the source documents, and according to the limitations of a single screen display.

Step 4. Prepare a SCREEN LAYOUT FORM for each program level. The purpose of the form is to lay out the prompts and fields exactly as they are to appear on the display.

(See Figure V-1 for illustration and description of SCREEN LAYOUT FORM.)

About The Screen Layout Form:

The Screen Layout Form is basically a worksheet for organizing all prompting messages and data fields as they will appear on a single screen display. Each screen display is the same as one program level.

Examples of completed forms follow. Note the following:

- Display screen lines 1 and 2 are reserved for system-supplied status information, and are not available for prompts or data fields. This is indicated by shading on form.
- A space for a system generated attribute byte must be left before each PROMPT and each FIELD. Position 1 of line 3 is shaded as a reminder to leave a space when filling out the form. A black dot is shown in each of the examples to indicate other spaces that have been left. (Screen columns 1 and 40 must always be blank.)
- The slash character (/) has been used to indicate FIELDS. One (/) is the same as one character position.

APPLICATION _____
 JOB NAME _____
 PROGRAM LEVEL _____ OF _____
 PAGE _____ OF _____

IBM SERIES 21
 FORMATTED DATA ENTRY PROGRAM
 SCREEN LAYOUT FORM

40-3617-0017

Figure V-1 FDE Screen Layout Form

Step 5.

Prepare an FDE JOB DEFINITION KEYING FORM for each program level. The purpose of this form is to extract from the Screen Layout Form the information about prompt and field positions and lengths, and to summarize specifications for each field.

(See Figure V-2 for illustration and description of JOB DEFINITION KEYING FORM, including Tables of Valid Entries for Field Definition fields.)

Entries on the Keying Form are used as data when the Job Description is written to diskette using procedures given in HOW TO ENTER A JOB DESCRIPTION.

1 HEADER INFORMATION:

APPLICATION — Enter general title for the Job. (This is for local filing purposes and is not used by the system.)

JOB NAME — Enter name that will be used as Data Set Name when Job Description is written to diskette. Name may be up to 8 characters, using alphabetic and/or numeric characters, excluding spaces.

PROGRAM LEVEL: — OF — Specify the program level to be described on this page of the form; enter the total number of program levels in this Job Description.

DATE — Enter date that form is prepared. (This is for local filing purposes and is not used by the system.)

PAGE__ OF ___ Specify this page number and the total number of pages of Keying Forms being used to define the Job. (this is for local filing purposes and is not used by the system.)

2 PROGRAM LEVEL DEFINITION:

LEVEL NO: — Enter the current program level number.

LEVEL INDICATOR — (Y or N) — Enter Y if program level number is to be written in position 128 of each record created in ENTRY mode; enter N if not.

AUTO RELEASE: — (Y or N) — Enter Y if data entered under this Job Description is to be automatically released to diskette when the last field in the program level is completed; enter N to specify manual release. (Manual release means pressing ENTER key is required to release record to diskette.)

NEXT LEVEL NO.: — Specify the next level to be automatically presented following completion of this level. (May be any of 10 program levels.)

3 PROMPT DEFINITION:

LIN — Enter the line number on the Display Screen where prompt will appear. Lines 03-12 are available for prompting messages.

COL — Enter the column of the attribute byte that precedes the prompt. Values 01-39 are valid.

MESSAGE — Enter the actual message that will appear as a prompt, using one space on the form per character.

4 DATA FIELD DEFINITION:

LINE — Enter the line number of the Display Screen where the data field will appear. Lines 03-12 are available for prompts and data fields.

NOTE:

For prompts that are as titles and not followed by a data field, enter zeros in the LIN, COL, LENGTH, MINIMUM, OP 1, OP 2 and RECORD POSITION columns of the form.

COLUMN — Enter the column of the attribute byte that precedes the first character of the data field. Valid entries are 01-39.

LENGTH — Enter the total number of character positions for the field. Range is 1-128.

NOTE:

The sum of all field lengths in a program level may not exceed 128, or 127 if LEVEL INDICATOR: Y.

MINIMUM — Enter the minimum number of significant characters that will be accepted for the field. All characters are significant except leading zeros and spaces, and trailing spaces. The value entered in MIN field cannot exceed the value of the LENGTH field.

MIN/O (MINIMUM OVERRIDE) — Enter Y or N. If Y, the number in MINIMUM specification may be ignored during entry of data to the field if a value of all zeros or spaces is keyed. If N, the number of characters specified in MINIMUM must be entered.

TYPE — Enter the character signifying the implied keyboard shift and the type of validation (if any) required for the field.

Code Letter	Stands For:	Description:
L	LETTER	Selects lower engraving. Note that alphabetic characters are encoded in upper case.
T	TEXT	Selects upper engraving if NUMERIC and CODE keys are pressed at the same time as shift.
A	ALPHA	Same as TYPE: L, but alphabetic characters are encoded in lower case.
D	DIGIT	Same as TYPE: L, with validation. (Range MUST BE A-Z. Spaces or use of SKIP key NOT allowed.)
N	NUMERIC	Selects lower engraving if ALPHA and CODE keys are pressed at the same time as a shift.
		Same as TYPE: D, with validation. (Range MUST BE 0-9. Spaces or use of SKIP key NOT allowed.)

SOURCE — Enter letter signifying the origin of the data for the field. May be K, D, A, or B.

Code Letter	Stands for:	Description:	Code Letter	Stands for:	Description:
K	Keyboard	Field accepts keyboard entry.	E	EXIT key or '-' key	Right adjusts characters in field. Requires EXIT key to leave field. If field TYPE: L, fill with spaces. If TYPE: T, fill with spaces.
D	Duplication	Field automatically filled with information duplicated from corresponding position(s) of the previous record.			If TYPE: A, BOUNDARY: E not allowed. If TYPE: D, fill with zeros. If TYPE: N, fill with zeros.
A	Auxiliary Duplication	Field automatically filled with information from corresponding position(s) of the previous record which used the same program level.	S	SKIP key	Left adjusts characters in field. Requires SKIP key to leave field. If TYPE: L, fill with spaces. If TYPE: T, fill with spaces.
B	Bypass	Field is automatically skipped.			If TYPE: A, BOUNDARY: S not allowed. If TYPE: D, fill with spaces. If TYPE: N, BOUNDARY: S not allowed.
			N	(Normal)	Does not require boundary checking.

BOUNDARY — Enter letter representing the method of boundary requirement for the field. May be E, S, or N.

OP1 and OP2 — Enter Code Number from those given to specify Operations required.

CHECK DIGIT may be used if field is numeric and rightmost character is to be validated by either method given.

ACCUMULATORS are used to arithmetically adjust the System-maintained Accumulators; may be total sum accumulation or zero balancing.

Only one of the two Check Digit Operations may be specified; the remaining OP field may be used to enter the Code for an Accumulator Operation, or left blank.

Two Accumulator Code Numbers may be entered in the OP fields, or only one, or the fields may be left blank.

Code	Check Digit Operation
00	(none)
01	IBM Mod 10 Check Digit
02	IBM Mod 11 Check Digit
Code	Accumulators Operation
03	Add to Accumulator 1
04	Add to Accumulator 2
05	Add to Accumulator 3
06	Add to Accumulator 4
07	Subtract from Accumulator 1
08	Subtract from Accumulator 2
09	Subtract from Accumulator 3
10	Subtract from Accumulator 4

RECORD POSITION — Enter the position within the record that the first character of the field will occupy when written to diskette record. May be 001-128.

5 RECORD LAYOUT

This portion of the form is used to summarize the field names in the actual sequence they will appear when written to the data set record.

HOW TO ENTER A JOB DESCRIPTION

- Step 1. Prepare Coding Forms, as described in preceding material.
- Step 2. Load FDE from Library Diskette, using procedures in PROGRAM LOAD section. The following display is presented.



FDE Function Selection Display

- Step 3. Key '5' to select JOB LOAD. The program presents the following Data Set Selection Display.

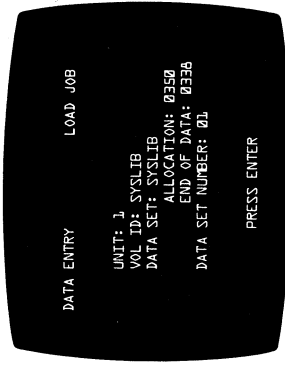

FDE Data Set Selection Display

Locate the dataset named JOBGEN on the Library Diskette by pressing SCAN to page forward through Data Set Names. When JOBGEN is displayed in the DATA SET: field, press ENTER. When the job is loaded, the FDE Function Selection Display is returned.

(The Library Diskette may be removed at this time, if desired.) Insert the diskette containing the data set to which the new Job Description will be written.

Step 5.

Key '1' to select ENTRY from the Function Selection Display. The Data Set Selection Display is presented.



FDE Data Set Selection Display

If the displayed Data Set Name is the correct one, press ENTER. If not, press SCAN to page forward through Data Set labels to locate it. When it is displayed in the DATA SET: field, press ENTER.

The program opens the data set, and presents the following JOBGEN display.

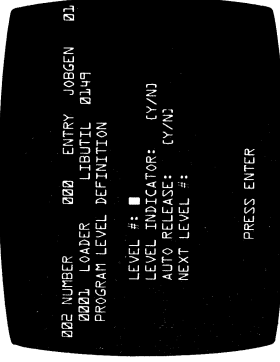

Program Level Definition Display

Step 6.

Key the Program Level information from the upper left portion of the FDE JOB DEFINITION KEYING FORM for the Job Description being entered. Press ENTER. The Field Definition Display is presented.

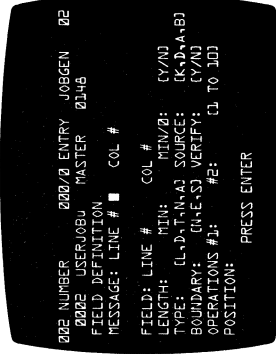

Field Definition Display

Key the Prompt and Field information from the first line of the FDE JOB DEFINITION KEYING FORM. Press ENTER. Another Field Definition Display is presented, to enable entry of the next line from the form.

Continue keying until all fields have been defined for this Program Level.

When keying of all Field Definitions for Program Level 01 are complete, proceed to next Program Level by pressing PROG ADV. Return to Step 6, and repeat keying procedure for each Program Level in the Job Description.

When no additional program levels remain to be entered, press SEL MODE. The FDE Function Selection Display will be presented.

Options include the following:

- a. Use SEARCH/UPDATE mode of FDE to visually check and, if needed, make corrections to, the Job Description just written to diskette. (Load JOBGEN as the Job to control this operation.)
- b. Use VERIFY mode of FDE to key-verify all manually-entered fields in the Job Description just written to diskette. (Use JOBGEN as the Job to control this operation.)
- c. Key '7' to select SIGN-OFF; this returns control to the Series 21 System software.

Step 7.

Step 8.

Table V-1 Summary of Function Keys Available During ENTRY and VERIFY Modes

KEY(S)	Effect during ENTRY	Effect during VERIFY
CODE	Enables special functions when pressed with another function key (see below). Also provides a third keyboard shift when pressed with a data key.	Same as for ENTRY.
DUP	Causes information from the corresponding field in the previous record to be duplicated into remaining positions of the current field of the current record buffer.	Causes information from the corresponding field in the previous record to be compared to the remaining positions of the current field in the current record. If there is a mismatch, or if there is no previous record, a 'KEYING ERROR' message results.
D/S OFF	<p>"Turns off" the automatic DUP-SKIP function for the next encountered DUP or SKIP field in the current program level; also allows entry of data in a bypass field.</p> <p>EXAMPLE: First field of a level is DUP, so cursor is positioned at the first non-DUP field. Press D/S OFF, then the Field Backspace key (←) to move cursor to the first character of the DUP field.</p>	Same as for ENTRY. In addition, allows entry into non-verify fields.

Table V-1 Summary of Function Keys Available During ENTRY and VERIFY Modes, continued

KEY(S)	Effect during ENTRY	Effect during VERIFY
D/S OFF, continued	After exiting from the automatic DUP or AUX-DUP field, the automatic DUP-SKIP function is again "turned on".	
CODE + D/S OFF	Same as D/S OFF described above, but turns off the automatic DUP-SKIP function until the entire record is complete.	Same as for ENTRY.
ENTER	Causes a record to be released from the screen and written to the dataset at EOD. Any alphabetic fields not keyed are space filled; any numeric fields not keyed are zero filled. DUP and AUX-DUP fields are copied from the previous record or record level.	Acts as repeated depressions of the Field Forward key (\longrightarrow). Verification is considered successful for the current level.
EXIT or '-'	Causes data to be adjusted to the right field boundary, with the Job defined fill characters automatically inserted to the left. Numeric fill = 0, Digit fill = blanks. The '-' (minus) key is used instead of the EXIT key for entering negative numbers.	Verifies the non-fill portion of the field automatically; fill characters are as stated for ENTRY.

Table V-1 Summary of Function Keys Available during ENTRY and VERIFY Modes, continued

KEY(S)	Effect during ENTRY	Effect during VERIFY
EXIT or '-'; continued	Attempting to leave a field with job-defined EXIT boundary checking without using the EXIT or '-' key results in a 'BOUNDARY ERROR' message.	A non-match results in a 'MISCOMPARE' message and the error light and tone are activated, plus: 1. IF FILL PORTION DOES NOT COMPARE, the cursor remains at the beginning of the field. 2. IF DATA PORTION DOES NOT COMPARE, the cursor returns to the first non-fill portion of the field.
HOME	Causes non-destructive cursor movement to the first manual position of the record; the entire record is displayed.	Same as for ENTRY.
CODE + HOME	Holding the CODE key down and pressing ENTER initiates a display and selection sequence for displaying ACCUMULATORS.	Same as for ENTRY, plus initiating a display and selection sequence enabling RECORD INSERT or DELETE, and resetting the VEOD pointer for re-opening a verified dataset at the first non-deleted record.

Table V-1 Summary of Function Keys Available During ENTRY and VERIFY Modes, continued

KEY(S)	Effect during ENTRY	Effect during VERIFY
MC	<p>Used to enter characters in Hexadecimal Code. This feature allows a character, not represented on the keyboard to be entered.</p> <p>PROCEDURE:</p> <ol style="list-style-type: none"> 1. Locate the desired character in the Hex Code table. 2. Press the MC key. 3. Key the 2-character code for the desired character. <p style="text-align: center;">NOTE:</p> <p>For Data Entry keyboards, MC and ALPHA must be held down while keying 'A-F', and MC and NUMERIC while keying '1-9'.</p> <ol style="list-style-type: none"> 4. The character code is displayed in the MC: —portion of the Production Display; a multiple slash character (/) is displayed in the data field position. 	<p>Used as described for ENTRY to verify characters entered in Hexadecimal Code.</p>



Table V-1 Summary of Function Keys Available During ENTRY and VERIFY Modes, continued

KEY(S)	Effect during ENTRY	Effect during VERIFY
PROG ADV	Causes the next sequential program level to be placed in control when pressed with cursor in "home" position of the record.	Same as for ENTRY.
CODE + PROG ADV	Holding the CODE key down and pressing PROG ADV places program level 01 in control.	Same as for ENTRY.
RESET	Used to acknowledge error messages and turn off the error indicator light and tone.	Same as for ENTRY.
CODE + RESET	Moves the cursor to the "home" position of the record and restores the contents of the original record with the entire record displayed. Any keyboard changes made to this unreleased record are gone.	Same as for ENTRY.
SCAN	Pages forward through existing records. Records are displayed as they are encountered (ignored at EOD).	Same as for ENTRY.
CODE + SCAN	Holding the CODE key down and pressing SCAN pages backward through existing records, and initiates UPDATE mode. Records are displayed as they are encountered (ignored at BOE).	Same as for ENTRY, except UPDATE/VERIFY mode is invoked only if at VEOD when CODE/SCAN is pressed.

Table V-1 Summary of Function Keys Available During ENTRY and VERIFY Modes, continued

KEY(S)	Effect during ENTRY	Effect during VERIFY
SEL MODE	<p>Pressing SEL MODE key at any time (except when the error indicator light is on) terminates ENTRY mode and returns the FDE Function Select Display.</p> <p>NOTE:</p> <p>SEL MODE may be pressed after pressing RESET key to respond to an I/O error.</p>	<p>Same as for ENTRY, causing termination of VERIFY mode.</p>
SKIP	<p>Causes data just keyed to be aligned with the left field boundary, and remaining unkeyed positions are space filled. An entire field may be space filled.</p> <p>Attempting to exit from a field with a job-defined SKIP boundary check without using the SKIP key results in a 'BOUNDARY ERROR' message.</p>	<p>Causes the current field to be verified for spaces. A non-space character in the field causes the cursor to stop in that position; 'MISCOMPARE' message is presented. Press RESET key, then SKIP key to replace the non-space with a space. Verification of the field continues.</p>
→	<p>Provides non-destructive forward cursor positioning to the first position of the next field. Unkeyed positions are treated as spaces except numeric fields which are zero filled.</p>	<p>Same as for ENTRY.</p>

Table V-1 Summary of Function Keys Available During ENTRY and VERIFY Modes, continued

KEY(S)	Effect during ENTRY	Effect during VERIFY
	Provides non-destructive backward cursor positioning to the first position of the current field (or previous field if pressed at the first position of a field). This key has no function in the "home" position.	Same as for ENTRY.
	Provides "destructive" cursor movement one character position to the left. This key has no function at the first position of a field.	Same as for ENTRY.
	Provide non-destructive cursor positioning, one character at a time, in the direction indicated by the arrow on the key top. Functional only within current field boundaries.	(ignored)

BSC COMMUNICATIONS PROGRAMS

The MDS Series 21 Communications options, BSC2780 and BSC3780, enable data transfer to or from a Series 21 terminal and associated equipment, such as:

- MDS 1200/2400 Systems or MDS 2300 System,
- IBM 2780 Data Transmission or IBM 3780 Data Communication Terminals,
- other Series 21 systems, and
- other systems using BSC protocols.

MDS also offers a facility called COMMUNICATIONS CUSTOMIZATION (COMMCUST) for use with the BSC2780 program, or 3780 CUSTOMIZATION (3780CUST) for use with the BSC3780 program. These customization programs may be used to:

- a. simplify operation of BSC2780 or BSC3780 and/or
- b. restrict definition of operational characteristics (I/O devices or features or both) to those available to your Series 21 system.

If COMMCUST or 3780CUST have been implemented at your installation, operation of BSC2780 or BSC3780 will be simplified to some extent. Use the operating procedures given in this section to perform any selection operations not already pre-selected by customization.

NOTE:

All error messages are acknowledged by pressing the RESET key. See MDS publication M-3925, *Series 21 Display Messages Manual, Rel 7.0*, for documentation of possible status/error messages and recovery procedures.

MDS supplies BSC COMM programs on Library Diskette for use with Series 21 systems that include either of the COMMUNICATIONS options.

Operating procedures provided in this section are organized as follows:

Title	Page	Title	Page
INTRODUCTION	1	TABLES and FIGURES	
BSC2780	3	Table VI-1 BSC2780 Operating Modes	18
Introduction	3	Table VI-2 BSC2780 Feature Support	19
Operating Mode Selection	4	Table VI-3 BSC3780 Functions	33
Feature Selection	5	Table VI-4 BSC3780 Feature Support	34
I/O Device Selection	7	Table VI-5 BSC3780 Device Select Field Entry Requirements	35
Reset Counters	10	Figure VI-1 Key to Information on BSC2780 Activity Monitor Display	12
Transmit Mode	11	Figure VI-2 Key to Information on BSC3780 Activity Monitor display	38
Receive Mode	16		
BSC3780	22		
Introduction	22		
Initiate	23		
Features	24		
Devices	25		
Reset Count	28		
Transmit/Receive	29		

BSC2780

INTRODUCTION

This section describes how to operate the Series 21 system when BSC2780 is loaded into the system. Organization of the material in this section follows a typical sequence of procedural steps:

1. Select Features
2. Select I/O Devices
3. Reset Counters (optional)
4. Select Operating Mode
 - a. Transmit
 - b. Receive
5. During 4a or 4b:
 - a. Observe Activity Monitor
 - b. Options:
 1. Terminate
 2. Disconnect
 3. Signal Remote

6. When FUNCTION COMPLETE for Transmit or Receive operation:

- a. Prepare for another COMM operation, or
- b. Sign off

NOTE:

All preliminary procedural steps, including pre-selection of I/O Devices, Features and Operating Mode may be performed automatically by the program upon PROGRAM LOAD if BSC2780 has been customized via COMMUCUST.

OPERATING MODE SELECTION

1. Load BSC2780 using procedures in PROGRAM LOAD section.
2. The Operating Modes Display will appear:

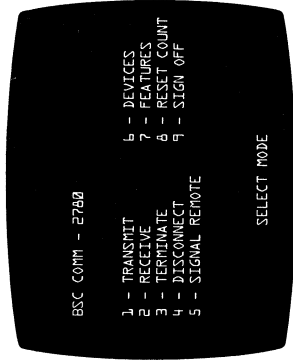

NOTE:

Customization of BSC COMM via COMMCUST allows pre-selection of Operating Modes; if your program has been customized, Communications activity may commence with no keyboard interaction.

Operating Modes Selection Display
(Refer to Table VI-1 for description of Operating Modes.)

NOTE:

I/O Devices and any features necessary for operation to be performed must be readied and selected prior to selection of TRANSMIT or RECEIVE.

FEATURE SELECTION

1. After loading BSC2780, the Operating Mode Selection Display is presented.

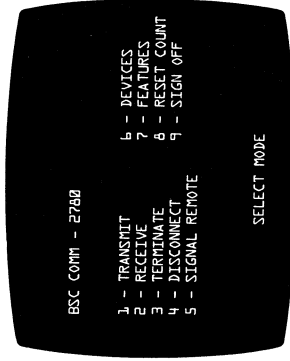

Operating Mode Selection display

2. Select 7 — FEATURES. The following Feature Selection Display is presented.

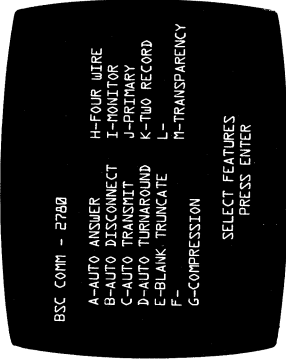

3. Select features that apply to your particular operation by pressing the corresponding alphabetic key. See Table VI-2, BSC2780 Feature Support, for description of features.
- An asterisk (*) appears to the left of each feature as its corresponding letter is pressed.
 - A feature is alternately selected and deselected each time its corresponding key is pressed.
 - To reset all features to their original lead time values, press CODE/RESET.

4. When all desired features have been selected, press ENTER. The Operating Mode Selection Display is returned.

NOTE:

If ENTER is pressed with NO features selected, the load time values are selected. See Table VI-2 of BSC2780 FEATURE SUPPORT.

I/O DEVICE SELECTION

1. After loading BSC2780, the Operating Mode Selection Display is presented.



Operating Mode Selection Display

2. Select 6 — DEVICES. The following Device Selection Display appears:

NOTE:

Standard defaults may be other than defined on the next page if COMMCUST has been used to customize I/O Device Selection.

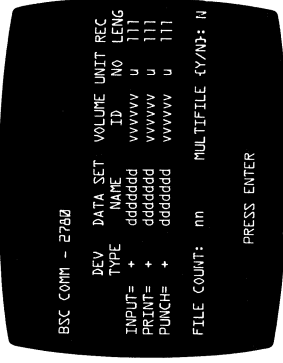

Device Selection Display

3. Key the information appropriate to the operation to be performed, according to the descriptions of each field that follows.
4. Press ENTER when Device Selection is complete. The Operating Modes Selection Display is returned.

NOTE:

Pressing SEL MODE prior to ENTER causes the program to disregard any keyed information.

DESCRIPTION OF FIELDS ON DEVICE SELECTION DISPLAY

Heading	Symbol	Description
DEV TYPE	+	F = diskette P = printer d = disk T = mag tape. Standard defaults are: INPUT — F, PRINT — P, PUNCH — F.

NOTE:

P not valid for INPUT device type.

NOTE:

When DEV TYP = T or P, DATASET NAME, VOLUME ID and UNIT NO. fields are underscore filled and cursor moves to REC LENG field.

NOTE:

Keying 'SKIP' for DEV TYPE causes underscore filling of DEV TYPE and remaining fields on that line. Cursor is moved to next DEV TYP field.

DATA SET NAME — INPUT	dddddd	Data set name containing data to be transmitted. Standard default value is DATAbbbb.
DATA SET NAME — PRINT	ddddddddd	Data set that will receive print data. Standard default value is _____ (underscore).

Heading	Symbol	Description
DATA SET NAME — PUNCH	ddddddd	Data set that will receive punch data. Standard default value is DATAAbbbb.
VOLUME ID	vvvvv	Volume Label name is _____ (underscore) for each line.
UNIT NO	u	(If diskette) Number of diskette drive unit. Standard defaults are INPUT —, PRINT — 0, and PUNCH —.
REC LENG	111	Record length of data set(s); values up to 134 allowed. Standard defaults are: INPUT — 080, PRINT — 132, and PUNCH — 080.
FILE COUNT	nn	Number of data sets to be transmitted. Range is 01-99. Standard default is 01.
MULTIFILE (Y/N)		Key Y if more than one data set will be transmitted. Otherwise, key N when several data sets will be transmitted as one file. Standard default is N.

NOTE:

To return default load time values to the Device Selection Display, press CODE/RESET.

RESET COUNTERS

Numeric counters are provided as part of the Activity Monitor Display that appears during data transfer using the TRANSMIT or RECEIVE modes of the BSC:2780 program.

The counter portion of the Activity Monitor Display presents the following information:

(1) SECTORS (2) XMIT (3) RCV (4) RETRY
 nnnnn nnnnn nnnnn nnnnn

KEY

- (1) SECTORS: nnnnn = the number of records inputted (including deleted records on diskette).
- (2) XMIT: nnnnn = the number of records transmitted.
- (3) RCV: nnnnn = the number of print or punched records received. The count increments by one for each record received.
- (4) RETRY: nnnnn = the number of NAKs (Negative Acknowledge messages) transmitted or received.

Use the following procedure to reset counters to zero prior to selecting TRANSMIT or RECEIVE for any particular operation:

1. Select 8 — RESET COUNTERS during presentation of the Operating Mode Display.

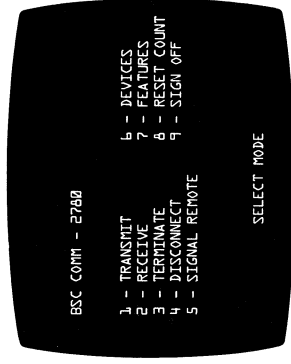

Operating Mode Selection Display

2. The Activity Monitor is presented briefly, then the Operating Mode Selection Display is returned. Continue with Mode Selection for your operation.

TRANSMIT MODE

1. Ensure that set-up procedures are complete.

NOTE:

Set-up procedures include the following:

- Loading BSC2780
- I/O Device Selection
- Feature Selection
- Reset Counters (if desired)

2. The Operating Mode Selection Display must be on the display screen. (If not, press SEL MODE.)

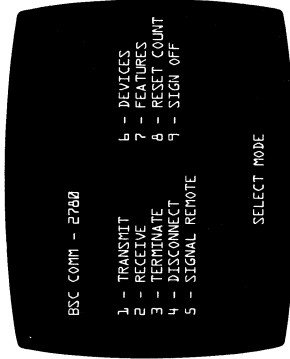

Operating Mode Selection Display

3. Select 1 — TRANSMIT to begin transmission of the data set specified in I/O Device Selection.

NOTE:

Data transmission will begin at BOE for disk or diskette data sets; if tape, at the current position.

The Activity Monitor Display is presented.

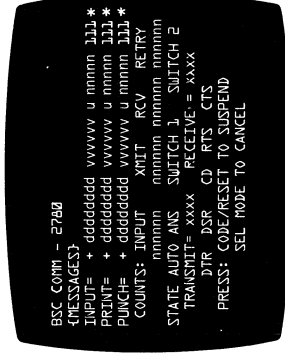

Activity Monitor Display

(Procedures resume on page 4.)

- 3 ddddddd: The active data set name selected during I/O Device Selection if DEVICE TYPE is F or D.
- 4 vvvvv: The Volume ID of the data set if DEVICE TYPE is F or D.
- 5 u: The unit number of the selected device if DEVICE TYPE is F or D.
- 6 nnnnn: The current number of records processed within the currently active data set. Deleted input records are not included in the count.
- 7 111: The record length for the data set specified during I/O Device Selection (134 characters maximum).
- 8 * : Indicates normal termination.
 - If on line 3, INPUT — indicates that EOD has been reached, the last transmitted record has been received and acknowledged, and the input data set has been closed.
 - If on lines 4 or 5 (PRINT or PUNCH), indicates the specified data set has been closed due to receipt of an EOT control sequence.
- 9 COUNTS: Current numeric counts incremented during present operation. (See RESET COUNTERS for description.)

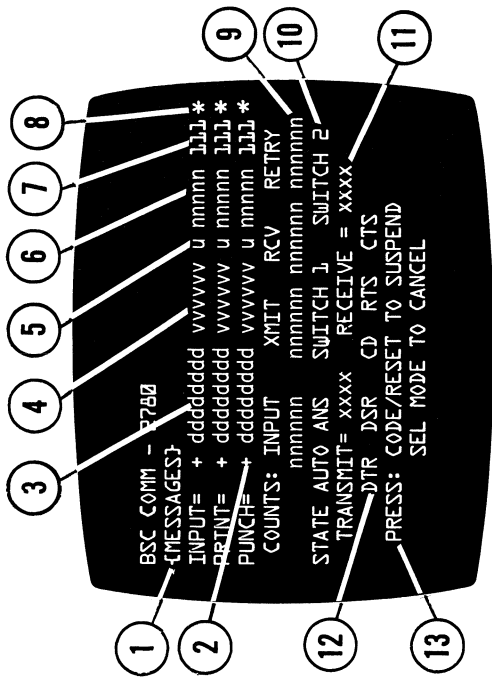

Figure VI-1 Key To Information On Activity Monitor Display

- 1 ERROR or PROMPTING MESSAGES: Press RESET to acknowledge. (See Error Messages, following, for explanations.)
- 2 DEVICE TYPE: Selected during I/O Device Selection. (F = diskette, D = disk, P = printer, T = magnetic tape).

10 STATE: Indicates current status of the data link:

TRANS = Transmitting
RCV = Receiving
IDLE = Inactive

AUTO-ANS. Present if AUTO-ANSWER feature was selected and COMM program is awaiting the Ring Indicator signal from the modem. When AUTO-ANS is displayed, STATE will contain TRANS or RCV to indicate the expected communications mode. If AUTO-ANS was not selected, field is filled with space characters.

Switch 1: Field contains AUTO-TRANS if the auto transmit feature was selected.

Switch 2: Field contains AUTO-TURN if the auto turnaround feature was selected.

11 Space filled except when MONITOR feature has been selected. If monitor, field contains most recently transmitted BSC sequence.

BSC control sequences include TEXT, TRSP, ACK0, ACK1, NAK, ENQ, WACK, T.O., RVI, TTD, EOT, or DEOT.

12 DTR, etc. : Field may contain any of five hardware conditions:

DTR = Data Terminal Ready
DSR = Data Set (Modem) Ready
CD = Carrier Detected
RTS = Request-to-Send
CTS = Clear-to-Send

13 PRESS . . . : Options available to operator during TRANSMIT or RECEIVE operations. (See Step 4, following.)

4. During communications activity in TRANSMIT Mode, two means are available for halting the Operation:

- Suspend by pressing CODE/RESET
- Cancel by pressing SEL MODE

a. Pressing CODE/RESET will temporarily halt communications data activity. The message COMMUNICATIONS SUSPENDED will appear on the Activity Monitor Display.

To resume communications activity, press CODE/RESET again.

NOTE:

When activity is suspended, TTD (Temporary Text Delay) or WACK (Wait Acknowledge) sequences are transmitted. Either TTD or WACK permits subsequent resumption of communications.

b. Pressing SEL MODE will cause the Operating Mode Selection Display to appear if no error message is pending, and terminate active COMM session.

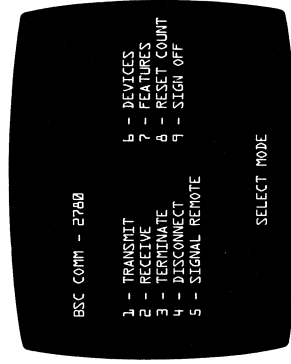

Operating Mode Selection Display

- Select 3 — TERMINATE if you wish to halt communications activity but maintain the line connection.
- Select 4 — DISCONNECT if you wish to halt communications and relinquish the line.
- Select 5 — SIGNAL REMOTE if you wish to signal the remote operator for voice communication.
- Select 9 — SIGN OFF if you wish to return control to Series 21 system software. The Program Selection Display will return.

5. When data transfer operation is complete, the message 'FUNCTION COMPLETE' appears on the Activity Monitor Display. Acknowledge by pressing RESET. The Operating Mode Selection Display returns, enabling set-up for another communications operation or selection of 9 — SIGN OFF to return control to Series 21 system software.

RECEIVE MODE

1. Ensure that set-up procedures are complete.

NOTE:

Set-up procedures include the following:

- Loading BSC2780 program
- I/O Device Selection
- Feature Selection
- Reset Counters (optional)

2. The Operating Mode Selection Display must be on the display screen. (If not, press SEL MODE.)



Operating Mode Selection Display

3. Select 2 — RECEIVE to begin receiving data to the data set(s) (devices) specified in I/O Device Selection. The Activity Monitor Display will be presented.

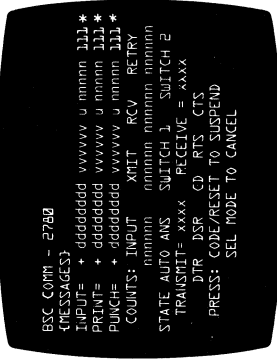

Activity Monitor Display

IMPORTANT:

See Figure VI-1, KEY TO INFORMATION ON ACTIVITY MONITOR DISPLAY.

4. During communications activity in RECEIVE Mode, two means are available for halting the operation:
 - Suspend by pressing CODE/RESET
 - Cancel by pressing SEL MODE

- a. Pressing CODE/RESET will temporarily halt communications data activity. The message COMMUNICATIONS SUSPENDED will appear on the Activity Monitor Display.

NOTE:

When activity is suspended, TTD (Temporary Text Delay) or WACK (Wait Acknowledge) sequences are transmitted. Either TTD or WACK permits subsequent resumption of communications activity.

- b. Pressing SEL MODE will cause the Operating Mode Selection Display to appear if no error message is pending, and terminate the active COMM session.

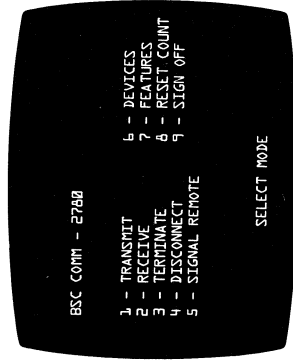

Operating Mode Selection Display

- Select 3 — TERMINATE if you wish to halt communications activity but maintain the line connection.
- Select 4 — DISCONNECT if you wish to halt communications and relinquish the line.
- Select 5 — SIGNAL REMOTE if you wish to signal the remote operator for voice communication.
- Select 9 — SIGN OFF if you wish to return control to Series 21 system software. The Program Selection Display will return.

5. When data transfer operation is complete, the message 'FUNCTION COMPLETE' appears on the Activity Monitor Display. Acknowledge by pressing RESET. The Operating Mode Selection Display is returned, enabling set-up for another communications operation, or selection of 9 — SIGN OFF to return control to Series 21 system software.

Table VI-1 BSC2780 Operating Modes

MODE	FUNCTION
1. TRANSMIT	Conditions BSC COMM to transmit data from the selected input data set (device).
2. RECEIVE	Conditions BSC COMM to receive data to the selected output data set [device(s)].
3. TERMINATE	Causes an EOT (End of Transmission) sequence to be transmitted.
4. DISCONNECT	Causes a DLE-EOT (disconnect) sequence to be transmitted.
5. SIGNAL REMOTE	Causes transmission of a BEL control character. (An appropriate message is displayed at the remote terminal to inform the remote operator that <u>voice communication</u> is desired.)
6. DEVICES	Causes the Device Selection Display to be presented; allows selection of specific input or output devices. (See I/O DEVICE SELECTION in this section.)
7. FEATURES	Causes the Feature Selection Display to be presented; allows selection of special operational features. (See FEATURE SELECTION in this section.)
8. RESET COUNT	Causes counters used on the Activity Monitor to be set to zero. (See RESET COUNTERS in this section.)
9. SIGN OFF	Terminates BSC2780 activity and returns control to the Series 21 system software.

Table VI-2 BSC2780 Feature Support

FEATURE	DESCRIPTION	DEFAULT
AUDIBLE ALARM	The BEL control character is transmitted and receiver posts 'GO TO VOICE' with an audible alarm.	None (feature always selected).
AUTO ANSWER	BSC COMM automatically answers an incoming call on a switched network; assumes operation is unattended, thus all specified input and output data sets and devices are checked to be a ready (openable) state at time transmit or receive mode is selected.	Manual answer.
AUTO DISCONNECT	BSC COMM transmits a DLE EOT (disconnect) sequence after a 20-second timeout or after receiving 15 NAKs (negative acknowledgements).	Transmission of an EOT (terminate) sequence under same conditions.
AUTO TRANSMIT	BSC COMM automatically enters transmit mode whenever idle state from receive mode is entered and data remains to be transmitted. If no data remains, BSC COMM remains in idle state. Receipt of an RVI (reverse interrupt) from the CPU automatically clears the feature during current session.	Transmit mode must be manually selected.
AUTO TURNAROUND	Receive mode is automatically selected whenever BSC COMM enters the idle state from transmit mode.	Receive mode must be manually selected.

Table VI-2 BSC2780 Feature Support, continued

FEATURE	DESCRIPTION	DEFAULT
BLANK TRUNCATE	Automatically inserts an EM (end of media) character after the last non-space character on a "card" image.	No blank truncation — entire image is transmitted.
COMPONENT SELECTION	Recognizes and acts on COMPONENT SELECTION sequences received from the host.	None (feature always selected).
COMPRESSION	(Transmit Mode) Provides for MDS 2400 compatible 2780 compression.	No compression.
FOUR WIRE	BSC COMM assumes a half duplex four-wire facility.	Two-wire facility.
HORIZONTAL TAB	Provides horizontal format control (TAB) functions for printer destined data.	None (feature always selected).
MONITOR	Communications exchanges are noted on the display. NOTE: A separate version of BSC COMM may be required in order to use the MONITOR feature.	No monitor.
PRIMARY	Terminal acts as primary 2780. NOTE: Selection of this feature has no meaning in a multipoint environment.	Terminal acts as a secondary 2780.

Table VI-2 BSC2780 Feature Support, continued

FEATURE	DESCRIPTION	DEFAULT
PROCESSOR INTERRUPT	<p>RVI (reverse interrupt) sequence is recognized as a positive acknowledgement to a transmitted block; the next block is transmitted and the line is released.</p> <p>NOTE: Receipt of an RVI automatically clears the AUTO TRANSMIT feature during current communications session.</p>	None (feature always active).
TWO RECORD	Transmits maximum of 2 rec/block.	Transmits maximum of 7 rec/block with block length limited to 400 bytes.
TERMINAL ID	<p>Causes transmission of Terminal Identification during line bid state.</p> <p>NOTE: Feature not operator selectable, and not available unless customized into BSC 2780 or compiled.</p>	No terminal ID transmitted.
TRANSPARENCY (EBCDIC)	Enables communication of any 8-bit code.	Communication of only non-transparent data.

INTRODUCTION

Customization of BSC3780 via 3780CUST allows pre-selection of FEATURES, I/O DEVICES, and/or FUNCTIONS.

- If your program has been customized, the system may proceed to TRANSMIT or RECEIVE mode with no operator interaction.
- If your program has not been customized, or if the customized version requires operator modification of FEATURES and/or DEVICES, a typical sequence of procedures is as follows:

SET-UP FOR OPERATION

- Load BSC3780 using procedures in PROGRAM LOAD section of this book. The Function Select Display is presented.
- Select C—INITIATE only if BSC3780 has been used for a preceding operation during current program load, and it is desired to return program to original default parameters. Otherwise, this step may be omitted.

- Select G—FEATURES. Activate Features required for your operation.
- Ready peripheral devices needed for operation.
- Select F—DEVICES. Specify Devices and data sets required for the data transmission to be performed.

- (Optional) Select I—VERIFY DEVICES if desired to direct program to locate all specified data sets.

- (Optional) Select H—RESET COUNTS to set counters in Activity Monitor to zero. (NOTE: If INITIATE function is used to reset default parameters, it is not necessary to Reset Counts as a separate step.)

OPERATION

- Select appropriate data transmission function:

A—TRANSMIT or B—RECEIVE

- Observe Activity Monitor during transmission; take appropriate operator action to support data transmission.

POST-OPERATION

- When transmission has ended, either:
 - Prepare for another COMM operation, or
 - Select D—DISCONNECT, then J—SIGN OFF to return control to Series 21 system software.

Use procedures in the subsections following to perform these steps.

INITIATE

1. Ensure that BSC3780 is loaded. (See PROGRAM LOAD section of this book for procedures.) The Function Select Display is presented.

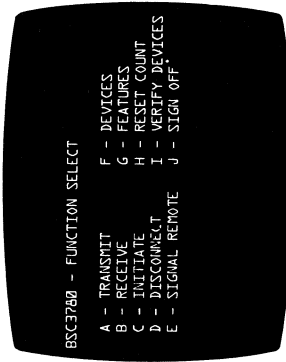

Function Select Display

See Table VI-3 at back of this section for explanation of BSC3780.

2. Select C — INITIATE.
 - a. If customized to require operator specification of FEATURES/DEVICES, the Feature Select Display is presented. (See FEATURES subsection for procedures.)
 - b. Otherwise, BSC3780 standard default values are re-established as shown below. The Function Select Display remains on the screen.

BSC3780 STANDARD DEFAULT VALUES FEATURES

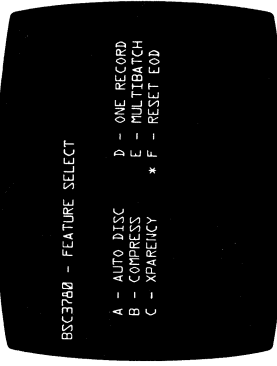

* = selected (space) = not selected

DEVICES

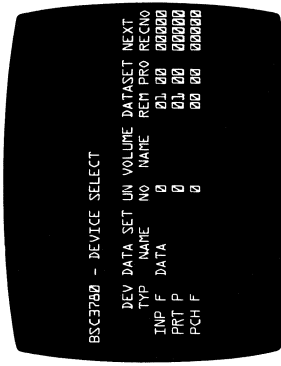

FEATURES

1. When loading of BSC3780 is complete, the Function Select Display is presented.



Function Select Display

NOTE:

Pressing SEL MODE at anytime during Feature Selection returns the Function Select Display.

2. Select G—FEATURES. The Feature Select Display is presented.

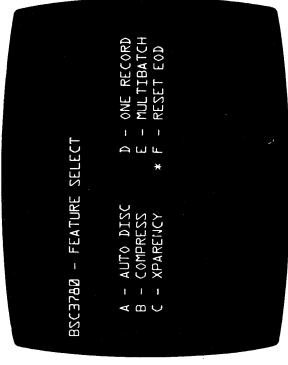

Feature Select Display

3. Key A, B, C, D, or E to select the Features shown. An asterisk (*) appears to the left of the letter on the display, indicating the Feature is activated. (As indicated on the display, F—RESET EOD is activated as a standard default parameter of the program.)
4. To de-select any Feature, press its corresponding letter. The asterisk (*) will be replaced by a space character, indicating the Feature is not activated.
5. When Feature Selection is complete, press ENTER. The Function Select Display returns.

NOTE:

Table VI-4 at the back of this section describes BSC3780 Feature support.

DEVICES

1. When loading of BSC3780 is complete, the Function Select Display is presented.

NOTE:

Pressing SEL MODE at any time during Device Selection returns the Function Select Display.

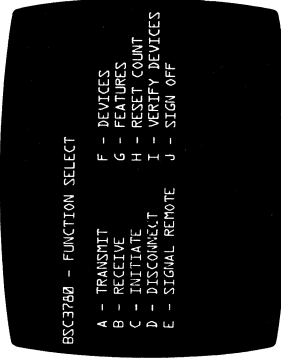

Function Select Display

2. Select F—DEVICES. The Device Select Display is presented. The cursor is positioned in the INP-DEV TYP field.

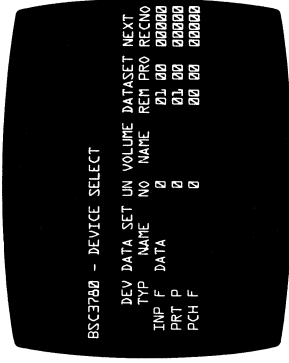

Device Select Display

(See Table VI-5 at back of this section for Field Entry Requirements.)

Key:

Abbreviations

DEV TYP	=	Device type
UN NO	=	Unit number
REM	=	Remaining
PRO	=	Processed
RECNO	=	Record number
INP	=	Input
PRT	=	Print
PCH	=	Punch

3. Key appropriate values according to these guidelines:

- If COMM operation will be TRANSMIT, entry is made on the input (INP) line of the display.
 - Enter Device Type in the DEV TYP column, dataset name in the DATASET NAME column, and the number of datasets to be transmitted in this operation in the DATASET REM column.

NOTE:

If more than '01' is keyed in REM column, the program will automatically search for the next dataset name in sequence (DATA0001 as first dataset, DATA0002 as second, etc.)

- Press ENTER. The program searches for the specified dataset name and, if found, provides UN NO (if diskette) and VOLUME NAME. The remaining fields are filled dynamically during data transmission operation.

c. The Function Select Display is returned.

- If COMM operation will be RECEIVE, entry is made on the Print (PRT) line of the display if output is printer or printer-destined, or on Punch (PCH) if output device is punch-destined.

- Enter Device Type in the DEV TYP column, and dataset name in the DATASET NAME column.
 - Press ENTER. The program searches for the specified dataset name and, if found, provides UN NO (if diskette) and VOLUME NAME. (The remaining fields are filled dynamically during data transmission operation.)
- c. The Function Select Display is returned.

• Applicable Control Keys:

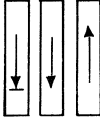

In case of keying errors, may be used to reposition cursor within a field or at beginning of field.



May be used to advance through fields that are optional or that require no entry (are program supplied during operation).



May be pressed at any time prior to pressing ENTER to abandon Device Selection and return Function Select Display.

4. When the Function Select Display has been returned following Device Selection process, I/O selections may be verified by selecting 1 — VERIFY DEVICES. The following display is presented:

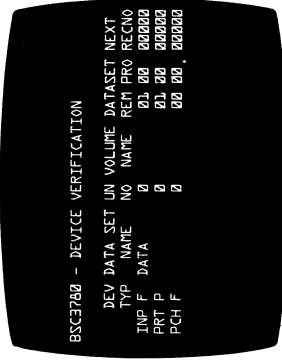

- c. If a dataset cannot be located the message 'NOT OPEN' appears on the message line of the display. Acknowledge message by pressing RESET key, and the Function Select Display is returned.

NOTE:

- Pressing SEL MODE at any time during Device Verification returns the Function Select Display.
- a. The program attempts to locate all specified INP, PRT and/or PCH datasets, including those implied if a number greater than '01' is specified in the DATASET REM field. (Example: DATA0001, DATA0002, etc.)
 - b. When all specified datasets have been located, the Function Select Display is returned.

RESET COUNT

1. To reset counters on the Activity Monitor Display (present during data transmission operation), select H — RESET COUNT from the Function Select Display.

Example Display:

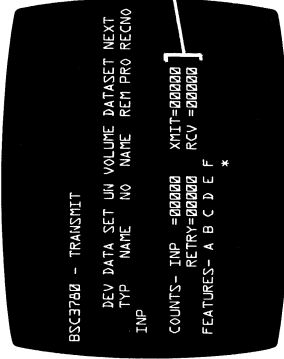

COUNTERS:
Fields are filled
dynamically during
data transmission
operation.

Activity Monitor Display

The Function Select Display remains on the screen while this function is performed.

TRANSMIT/RECEIVE

1. Ensure that set-up procedures are complete. The steps include:
 - Loading BSC3780
 - Ready peripheral devices needed
 - Selecting Features/Devices needed
 - Specifying datasets for INP, PRT, or PCH.
2. The BSC3780 Function Select Display must be present on the display screen for operator selection of transmission mode. If not, press SEL MODE.
3. Select mode for data transmission operation.
 - a. If data is to be transmitted from Series 21 terminal to a remote terminal, select A — TRANSMIT. The following Activity Monitor Display is presented.

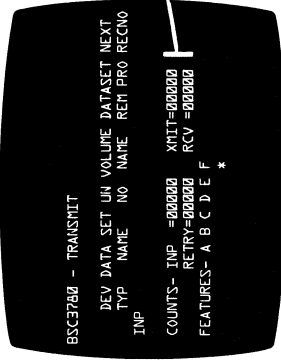

Activity Monitor Display

NOTE:

For a complete Key to Activity Monitor, see Fig. V-2 at the end of this section.

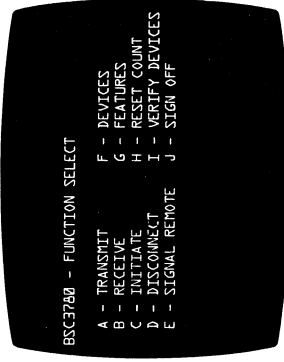

Function Select Display

- b. If data is to be transmitted from a remote terminal to Series 21 terminal, select B — RECEIVE. The following Activity Monitor Display is presented.

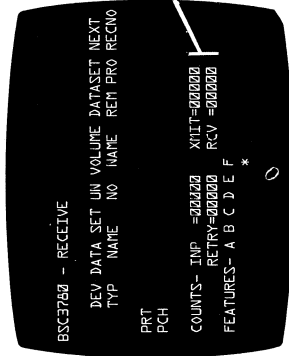

COUNTERS:
Fields are filled dynamically during operation.

Activity Monitor Display

- 4. The program proceeds automatically to establish the data link between Series 21 System terminal and the remote terminal.
 - The message 'MODEM NOT READY' may be presented on the message line of the display if link cannot be established immediately. The program continues to retry until link is established.
 - Pressing SEL MODE will end operation and return the Function Select Display.

- 5. When BSC3780 establishes the data link, the program attempts to open the specified INP, PRT or PCH dataset.
 - If dataset can be opened, transmission begins. Go to Step 6.
 - If not, the following display is presented so that operator can reselect the data set.

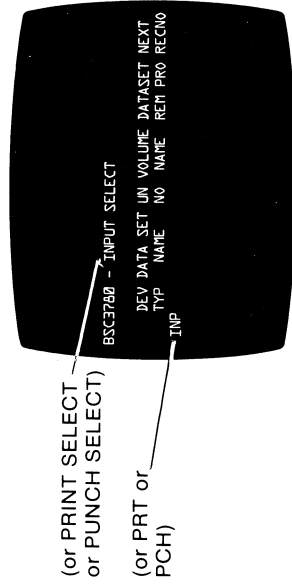

Enter appropriate values in DEV TYP, DATASET NAME, and DATASET REM columns. (UN NO and VOLUME NAME entries are optional.) Press ENTER when entry is complete.

BSC3780 repeats attempt to open the specified dataset. If successful, transmission begins. If not, repeat procedure of reselection or press SEL MODE to abandon effort.

NOTE:

During normal transmission, Print Select or Punch Select Displays may be presented to indicate EOM (End-of-Medium) has been reached. Transmission can resume when new specifications are entered, using foregoing procedure, and newly specified dataset is successfully opened.

NOTE:

If data received from remote is undirected and both PRT and PCH devices have been allowed, the OUTPUT will default to the PRT device.

6. During data transmission in TRANSMIT or RECEIVE mode, the following option is available:

- Abort transmission by pressing SEL MODE. This causes BSC3780 to send an 'INCOMPLETE TRANSMISSION' message to the remote terminal, and to return the Function Select Display.

7. If transmission is aborted by operator action, as in Step 6, the following options are available.

- Re-initiate COMM activity, starting with set-up procedures for another operation.
- Select E — SIGNAL REMOTE, causing a BEL character to be transmitted to the remote terminal, indicating that voice communication with remote operator is desired.

- Select D — DISCONNECT to relinquish data link, then J — SIGN OFF to return control to Series 21 system software.

8. Normal termination of data transmission operation may occur as follows:

- a. In TRANSMIT mode when EOF (End-of-File) is reached on the INP dataset and the Input DATASET REM has reached '00'.

NOTE:

The program automatically enters RECEIVE mode if 1) set-up procedures have included entry of PRT or PCH dataset specifications and 2) the Print or Punch DATASET REM field contains '01' or a number greater than 01. If not, the Function Select Display is returned.

- b. In RECEIVE mode when an EOD (End of Transmission) is received from the remote terminal.

NOTE:

The program automatically enters TRANSMIT mode if 1) set-up procedures have included entry of INP dataset specifications, and 2) the Input DATASET REM field contains '01' or a number greater than 01. If not, the Function Select Display is returned.

9. If normal termination is reached and the Function Select Display is returned, the following options are available:
 - Re-initiate COMM activity, starting with set-up procedures for another operation.
 - Select D — DISCONNECT to relinquish the data link, then select J — SIGN OFF to return control to Series 21 System software.

Table VI-3 BSC3780 Functions

KEY	FUNCTION	EFFECT
A	TRANSMIT	Conditions BSC3780 to transmit data from the selected input data set(s).
B	RECEIVE	Conditions BSC3780 to receive data from the selected output data set(s).
C	INITIATE	Returns default values to Device Selection Display and/or Feature Selection Display if modification to either has been allowed in previous operation during current program load.*
D	DISCONNECT	Causes DLE-EOT (disconnect) sequence to be transmitted.
E	SIGNAL REMOTE	Causes transmission of a BEL control character. (An appropriate message is displayed at the remote terminal to inform the remote operator that <u>voice communication</u> is desired.)
F	DEVICES	Causes the Device Selection Display to be presented; allows selection of specific I/O devices. (See DEVICE SELECTION.)
G	FEATURES	Causes the Feature Selection Display to be presented; allows selection/deselection of special operational features. (See FEATURE SELECTION.)
H	RESET COUNT	Causes counters used on the Activity Monitor present during either TRANSMIT or RECEIVE to be reset to zero. (See RESET COUNTERS.)
I	VERIFY DEVICES	Causes BSC3780 to locate and verify readiness of datasets specified during I/O Device Selection.
J	SIGN OFF	Terminates BSC3780 activity and returns control to the Series 21 System software.

* Default values are either the standard defaults established in BSC3780, or those selected during customization of BSC3780 using 3780 CUST.

Table VI-4 BSC3780 Feature Support

FEATURE	DESCRIPTION (If active)	(If inactive)	DEFAULT*
AUTO DISC	Program transmits a DLE EOT (disconnect) sequence after a 20-second timeout or after receiving 15 NAKs (negative acknowledgements). If selected, AUTO ANS also automatically selected.	Transmission of EOT (terminate) sequence under same conditions.	I
COMPRESS	(TRANSMIT mode) Causes IBM 3780 compatible compression.	No compression.	I
XPARENCY (EBCDIC)	Enables transmission of any 8-bit code.	Transmission of only non-transparent data.*	I
ONE RECORD	Transmits 1 rec/block. Controls number of records transmitted per block of text or transparent text.	Transmits as many records as will fit into a 480-byte block.	I
MULTIBATCH	Terminates the final text block of each INP dataset with an ETX.	Each INP dataset's final transmitted text block is terminated with an ETB; final dataset terminated with an ETX.	I
RESET EOD	In RECEIVE, causes EOD to be set at default value (usually zero).	EOD is not reset.	A

*I = inactive; A = active

*BSC control characters SYN, EOT, ENQ, NAK, DLE, ETB, ETX, IVS, IGS, and IRS are not allowed as data characters.

Table VI-5 Device Select Field Entry Requirements

FIELD	COLUMN HEADING	DESCRIPTION	VALID ENTRY	DEFAULT VALUE	ENTRY REQUIRED?
INP (Input)	DEV TYP	Specifies device type for current INP dataset.	'F' = diskette 'D' = disk 'T' = mag tape	F	Yes
INP (Input)	DATASET NAME	Specifies name of current INP dataset.	Any 8-character dataset name*	DATA	Yes if F or D
INP (Input)	UN NO	(If diskette) Unit number of diskette drive in which specified dataset is resident.	1-4 or 0	0	No
INP (Input)	VOLUME NAME	(If diskette or disk) Volume name.	6-character Volume name	(space filled)	No
INP (Input)	DATASET REM	Specifies number of INP datasets for current operation.	00-99	01	Yes, unless default is used.
INP (Input)	DATASET PRO	Reports number of INP datasets processed.	None (program fills field during operation).	00	No
INP (Input)	NEXT REC NO	Reports number of next INP record to be read during operation.	None (program fills field during operation).	00000	No

*If more than one dataset will be used, program will follow sequence such as DATA0001, DATA0002, etc.

Table VI-5 Device Select Field Entry Requirements, continued

FIELD	COLUMN HEADING	DESCRIPTION	VALID ENTRY	DEFAULT VALUE	ENTRY REQUIRED?
PRT (Print)	DEV TYP	Specifies device type for current PRT dataset.	'F' = diskette 'D' = disk 'T' = mag tape 'P' = printer	P	Yes
PRT (Print)	DATASET NAME	Specifies name of current PRT dataset.	Any 8-character dataset name*	(space filled)	Yes if F or D
PRT (Print)	UN NO	(If diskette) Unit number of diskette drive in which specified dataset is resident.	1 - 4 or 0	0	No
PRT (Print)	VOLUME NAME	(If diskette or disk) Volume name.	6-character Volume name	(space filled)	No
PRT (Print)	DATASET REM	Specifies number of PRT datasets for current operation.	00 - 99	01	Yes, unless default is used
PRT (Print)	DATASET PRO	Reports number of PRT datasets processed.	None (program fills field during operation).	00	No
PRT (Print)	NEXT REC NO	Reports number of next PRT record to be written during operation.	None (program fills field during operation).	00000	No

*If more than one dataset will be used, program will follow sequence such as DATA001, DATA002, etc.

Table VI-5 Device Select Field Entry Requirements, continued

FIELD	COLUMN HEADING	DESCRIPTION	VALID ENTRY	DEFAULT VALUE	ENTRY REQUIRED?
PCH (Punch)	DEV TYP	Specifies device type for current PCH dataset.	'F' = diskette 'D' = disk 'T' = mag tape 'P' = printer	F	Yes
PCH (Punch)	DATASET NAME	Specifies name of current PCH dataset.	Any 8-character name*	(space filled)	Yes if F or D
PCH (Punch)	UN NO	(If diskette) Unit number of diskette drive in which specified dataset is resident.	1 - 4 or 0	0	No
PCH (Punch)	VOLUME NAME	(If diskette or disk) Volume name.	6-character Volume name	(space filled)	No
PCH (Punch)	DATASET REM	Specifies number of PCH datasets for current operation.	00 - 99	00	Yes
PCH (Punch)	DATASET PRO	Reports number of PCH datasets processed.	None (program fills field during operation).	00	No
PCH (Punch)	NEXT REC NO	Reports number of next PCH record to be written during operation.	None (program fills field during operation).	00000	No

*If more than one dataset will be used, program will follow sequence such as DATA001, DATA002, etc.

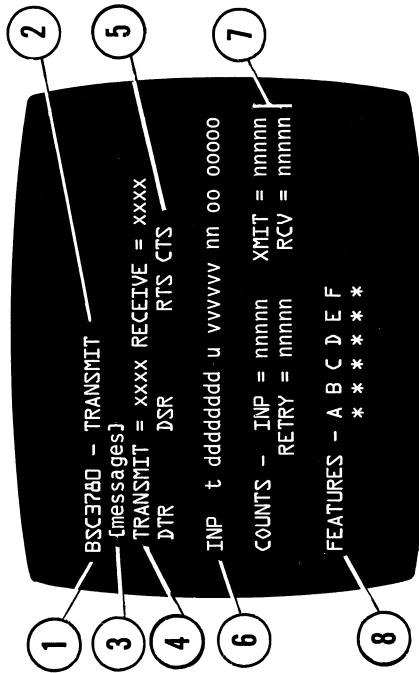

Figure VI-2 Key To Activity Monitor Display

- 3 Message line reserved for Operator Attention messages generated by program and I/O messages generated by system software.
- 4 The last transmitted and received BSC messages appear in the appropriate "xxxx" field. Messages include "TEXT", "TRSP", "ACKØ", "ACK1", "NAK", "ENQ", "WACK", "T.O.", "RV", "TTD", "EOT", "DEOT", or spaces (IDLE).
- 5 The presence of any of five hardware conditions are indicated as follows: DTR=data terminal ready; DSR = data set (modem) ready; CD = carrier detected; RTS = request to send; CTS = clear to send.
- 6 Details about current INP (or PRT or PCH) dataset are dynamically updated during operation.
- 7 COUNT fields report as follows: INP = number of records read from the INP dataset for transmission, not including records read but not yet transmitted; RETRY = number of NAKs transmitted or received for this transmission; XMIT = number of INP records successfully transmitted; RCV = number of text blocks successfully received. Initial count for all fields is zero.
- 8 Indicates which features are active during current operation; letters A – F correlate with selection letters on Feature select display. Asterisk (*) below letter indicates corresponding Feature is active.

- 1 Name of Series 21 application program.
- 2 Transmission mode (either TRANSMIT or RECEIVE).

MOBOL COMPILER

The MOBOL Compiler is an MDS-supplied software package which converts user-written source programs into object programs, ready to run on System 21/40. The Compiler is provided on diskette. For complete information on MOBOL, consult the *MOBOL Reference Manual* (Form No. M-2612).

Title	Page
Description	2
Compiler	3
MOBOLIST	6

DESCRIPTION

Source programs may be recorded by the user on diskette, using the MDS Formatted Data Entry Program (FDE). The allocation requirements of SOURCE and NOTES are decided by the size and the complexity of the source program, while the OBJECT requires a minimum of 300 records. The operator is responsible for satisfying the minimum allocation requirement. The MOBOL Compiler needs three Data Sets which can be allocated using the DSKETTEU program. The three data sets are:

- SOURCE — Input statements written by the user in MOBOL language.
- OBJECT — The executable MOBOL program, output by the Compiler.
- NOTES — Syntax errors in source statements, detected during compilation. Using an MDS-supplied utility called MOBOLIST, these error or warning messages can be merged with the original input statements to produce an annotated source listing on a printer or display screen.

NOTE:

Unlike other MDS-supplied programs, the MOBOL Compiler is prohibited from more than one operator access at a time due to its sophisticated execution environment.

COMPILER OPERATION

1. Controller Console — POWER On.
Operator Station — Power ON.
2. Insert the Library Diskette containing the MOBOL Compiler.

NOTE:

If Library Diskette has been previously loaded, select SIGN OFF from the Function Selection Display; otherwise, press RESET button on Controller Console to load Library Diskette.

3. Wait for the Program Selection Display to appear on the display screen.

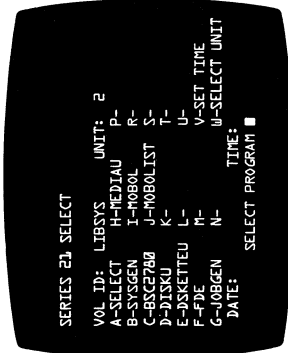

Program Selection Display

4. Key the letter shown for MOBOL Compiler.
The Data Set Display appears when loading is complete.

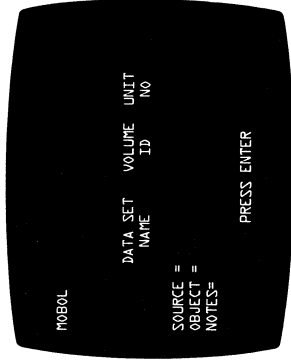

Data Set Display

5. The order of keying the fields is arranged as follows:

1. SOURCE data set name
2. OBJECT data set name
3. NOTES data set name
4. SOURCE volume ID
5. SOURCE unit no.
6. OBJECT volume ID
7. OBJECT unit no.
8. NOTES volume ID
9. NOTES unit no.

But, the operator can use the two field move keys (**→**) and (**←**) to change the order of input, or use the HOME key to position the cursor to the first field (i.e., SOURCE data set name).

6. After the three data set names have been defined, the operator can press the ENTER key any time to signal the end of input. Then, the Compiler tries to locate the data set names on the volumes of the devices. If the unit number is left blank by the operator, the search starts with the lowest numbered unit and proceeds sequentially through all the units or until the data set is found. Similarly, if the VOLUME ID is left blank by the operator, the Compiler looks for the first volume containing the requested data set name.

7. If a data set can be found, its VOLUME ID and device unit number are temporarily fixed and are used to replace the blank volume or unit (if any) on the display; if not found, an error message is displayed in the message field. For instance, the message "SOURCE OBJECT — NOT FOUND" is displayed if neither can be found. Only under the condition that the search for all the data sets succeeds, the Compiler proceeds to Step 8; otherwise Step 5 is re-entered; meanwhile, all the temporarily fixed data sets are unfixed and subject to changes. However, the operator can use some of them as inputs again simply by leaving them on display.

8. All the three temporarily fixed data sets become permanently fixed (with the exception stated in Step 9) and the compilation takes place. The Compiler also presents the MOBOL Compilation Display, which remains active during the compilation process.

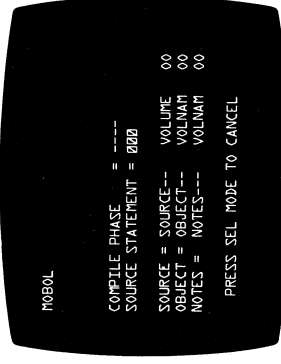

MOBOL Compilation Display

COMPILE

PHASE = the current compile phase is presented as one of the following:

DATA: processing the data definition section
START: wrap-up of data definitions
CODE: processing the executable section
BUSY: compile wrap-up

SOURCE

STATEMENT = the number of the current source statement being compiled.

SOURCE = data set name

VOLUME = volume ID

00 = device unit number

Pressing the SEL MODE terminates the compilation prematurely, and returns the Program Selection Display. The contents of both OBJECT and NOTES from this termination is unpredictable.

9. If the Compiler reaches EOD (End of Data) prior to detecting an END source statement, it assumes that there are multiple source data sets. The Compiler then searches for the next SOURCE data set. The new data

set name is generated by using the previous data set name with the EBCDIC value of its rightmost character incremented by 1. The VOLUME ID and unit number of the new data set are considered as unrestricted in this case. If the new data set is found, Vol. ID and unit number reflect on the display accordingly, and then the compilation continues with the new SOURCE data set.

NOTE:

The Compiler will wait for either the proper data set to be mounted or the depression of SEL MODE to terminate.

Since the number of source data sets for one compilation is not limited, a source program can consist of multiple data sets (with names properly incremented) on different device units.

10.

The Compiler ends. The system displays the Program Selection Display for next operation. The pertaining syntax errors diagnosed by the Compiler can now be printed with or without the source statements via an MDS-supplied utility called MOBOLIST. (For discussion of MOBOLIST and procedures, see p.6.) If no error message is given, the OBJECT is ready for execution by the MDS-supplied interpreter called PXQ.

MOBOLIST

An MDS-supplied utility program called MOBOLIST may be used to list SOURCE or NOTES (syntax errors detected by the MOBOL Compiler during compilation). If errors exist, these listings may be used as a guide to the programmer to correct, update, or revise locally-prepared programs.

```
0020. *
0021. *
0022. *
0023. *
0024. *
0025. *
0026. *
0027. *
0028. *
0029. *
0030. *
0031. *
0032. *
0033. *
0034. *
0035. *
0036. *
0037. *

DATA DEFINITION

DISPLAY 1
KET : DISPLAY 1
CRTSIZE = 480
BLANK = CRT SIZE
(1,1) 'SAMPLE MOBOLIST PROGRAM
(3,1) 'PROGRAM WRITES THE WORD HELLO'
(5,1) 'TO RUN --PRESS ENTER--';

DISPLAY 2

LET : DISPLAY 2
CRTSIZE = 480
BLANK = CRTSIZE
(5,1) 'HELLO'
```

Example of Listing using MOBOLIST, SOURCE LIST Function

M O B O L I S T L E V E L 6 . B A N N O T A T E D S O U R C E L I S T

OBJECT DATA SET = OBJECT

0027. BLANK = CRT SIZE
 0028. (1,1) 'SAMPLE MOBOLIST PROGRAM
 *0028. 50 MISSING QUOTE

0033. LET : DISPLAY 2
 0034. 10 MISPELLED KEYWORD
 *0034.

0035. CRTSIZE = 480
 0036. BLANK = CRTSIZE
 *0036. 00 SYNTAX ERROR

0036. BLANK = CRTSIZE
 0037. (5,1) 'HELLO'
 *0037. 10 SYNTAX ERROR

Example of Listing using MOBOLIST, ANNOTATED SOURCE LIST Function

MOBOLIST OPERATION

1. Controller Console — POWER On.
Operator Station — Power ON.
2. Ready the Printer that will be used (see PERIPHERALS).
3. Insert the Library Diskette containing MOBOLIST.

Wait for the Program Selection Display to appear on the display screen.

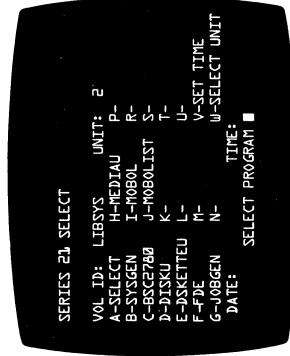

Typical Program Selection Display

4. Key the letter shown for MOBOLIST. The Function Selection Display appears.

NOTE:

(OPTIONAL: The Library Diskette may be removed at this time.)



Function Selection Display

NOTE:

Press SEL MODE at any time during MOBOLIST operation to return to Function Selection Display.

5. If listing of a SOURCE Program only is desired, select 1 — SOURCE LIST. The following display will appear.

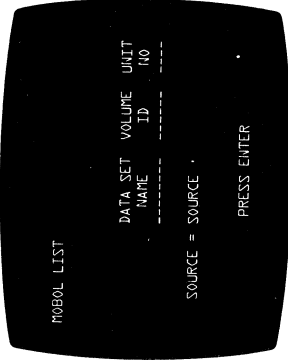

- Insert the diskette containing the SOURCE program to be listed.
- Key the Data Set Name that contains the SOURCE program, the Volume ID of the diskette containing the Data Set, and the Unit No. of the diskette drive being used. Press ENTER.
- When the function is complete, the MOBOLIST Function Selection Display returns. Select 6 — SIGN OFF if no further listings are required.

6. If listing of NOTES only is desired, select 2 — NOTES LIST. The following display will appear:

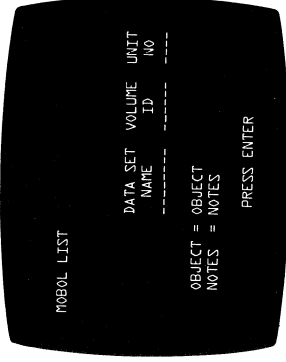

- Insert the diskette(s) containing the NOTES file and OBJECT program.
- Key the Data Set Name that contains the NOTES for the SOURCE program, the Volume ID, and diskette drive unit number.
- Key the Data Set Name that contains the OBJECT program, the Volume ID, and Unit number.
- Press ENTER.
- When the function is complete, the MOBOLIST Function Select Display returns. Select 6 — SIGN OFF if no further listings are required.

7. If either an annotated SOURCE LIST or a combined listing of the SOURCE program and NOTES file are desired, select:

3 — ANNOTATED SOURCE LIST

or

4 — SOURCE & NOTES LIST

The following display will appear:

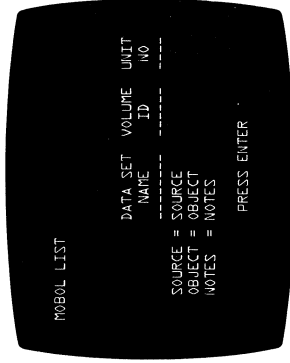

- a. Insert the diskette(s) containing the data sets of the SOURCE program, OBJECT program, and NOTES file.
 - b. Key the Data Set Names, Vol. IDs and Unit Nos. of the SOURCE program, the OBJECT program, and the NOTES file.
 - c. Press ENTER.
 - d. When the function is complete, the MOBOLIST Function Select Display returns. Select 6 — SIGN OFF if no further listings are required.
8. Key '5' to if ANNOTATED Display is desired. The following display is presented:

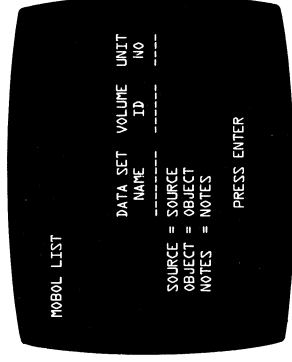

- a. Insert the diskette(s) containing the data sets of the SOURCE program, OBJECT program, and NOTES file to be displayed.
- b. Key the Data Set Names, Vol IDs and Unit Nos. of the desired data sets.
- c. Press ENTER.
- d. The program displays the designated SOURCE program with annotation.
- e. Press SEL MODE to return the MOBOLIST Function Select Display. Select 6 — SIGN OFF if no further listings are required.

MEDIA UTILITIES

The MDS-supplied Media Utility program (MEDIAU) provides functions enabling a number of data set transcription operations, default I/O specifications supporting transcription operations, and auxiliary magnetic tape utility operations.

NOTE:

Additional data set operations are available using the MDS-supplied programs Data Management Utilities (DMU) and Diskette Utilities (DSKETTEU) programs, described in separate sections of this publication.

INTRODUCTION

The Media Utilities program (MEDIAU) is supplied by MDS on a Library Diskette. It contains the following major functions:

- Device Control, used to specify I/O devices prior to Data Transcription operations using MEDIAU.
- Data Transcription, including "literal" transcription (COPY), unformatted display (DISPLAY), decompression of compressed data (PRINT) destined for printer via COPY, and annotated hexadecimal list (DUMP)

- Magnetic Tape Utilities, used to perform various file delineation and positioning operations, including file skip and record skip (forward and reverse), rewind and rewind lock, tape mark generation, and forward skip to EOF.

NOTE:

Error and Status messages that may be received during operation of MEDIAU are documented in MDS publication M-3925, *Series 21 Display Messages Manual for Rel. 7.0*.

The following subsections provide detailed procedures for each function contained in MEDIAU:

Title	Page
Introduction	1
Device Control	2
Data Transcription	8
Copy	9
Display	10
Print	11
Dump	12
Magnetic Tape Utilities	14

DEVICE CONTROL

The Device Control function (DEVICES) of MEDIAU is used to specify default input and output files, the number of inputs to be transcribed in Data Transcription operations, and whether or not the EOD (End of Data) pointer is to be set for output.

Usually, I/O default specifications are performed using DEVICES function of MEDIAU prior to initiating operations using any of the four Data Transcription functions (COPY, DISPLAY, PRINT or DUMP) of MEDIAU. Otherwise, I/O specifications may be made after selection of a Data Transcription subsection, following:

BEFORE YOU START

- **Controller Console Power must be On.**
- **Operator Station Power must be On.**
- **Data Set Label names should be changed, if necessary, using DSKETTEU to conform with requirements of particular operation to be performed.**
- **MDS Media Utilities program (MEDIAU) must be loaded from your operator station; if not, see PROGRAM LOAD section of this publication.**

1. If the Function Selection Display is present on your Display Screen, go to Step 2; if not, press SEL MODE.

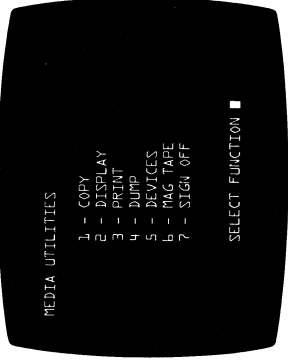

MEDIAU Function Selection Display

2. Key a '5' to select DEVICES. The following display will be presented.



Devices Selection Display

(Procedures continue on page 5.)

DESCRIPTION OF FIELDS ON DISPLAY

COLUMN HEADING	VALID ENTRY	NOTES
DEV TYP	<p>F = diskette D = disk T = tape C = compatible channel O = no selection</p>	<p>If F or D are keyed, SCAN or CODE/SCAN control keys may be used to display Data Set Names after entry in UN or VOL NAME field.</p> <p>NOTE: For INP if DEV TYP is 'T' or 'C', cursor advances to DATASET REM field. For OUT if DEV TYP is 'T', 'C' or 'P', selected function begins immediately.</p>
DATASET NAME	<p>Key the desired 8-character Data Set name, or locate Data Set name using method given at right.</p> <p align="center">OR</p> <p>Key X'FF' if entire diskette or disk is to be transcribed.</p>	<p>If desired Data Set name is fewer than 8 characters, the SKIP key or (→) Field Forward key to advance to the next field.</p> <p>Enter hexadecimal 'FF' (X'FF') by first pressing MC key, then holding ALPHA key depressed while keying 'FF'.</p>
UN NO	<p>If diskette, key 1-4 to designate number of diskette drive containing INP; if disk, key 1. SKIP field if T or C.</p>	<p>Entry optional if Data Set specified in previous field.</p> <p>NOTE: If UN NO is specified, program will search that unit only for designated Data Set.</p>

DESCRIPTION OF FIELDS ON DISPLAY, continued

COLUMN HEADING	VALID ENTRY	NOTES
VOL NAME	If F or D, 6 character Volume Name may be entered; SKIP field if T or C.	Entry optional if Data Set specified in previous field.
DATASET REM	Key the number of Data Sets to be INP in REM field (range is 01–99).	If nn is greater than 01, the system will search for Data Set names in sequence beginning with ddddd01. (See example on next page.)
DATASET PRO	No entry in PRO field; this field is filled by system during transcription operation if REM = 01.	
NEXT REC NO	No entry; this field is filled by system during transcription operation to indicate the next record following the one being copied.	Field value represents next record available for INP or OUT, rather than indicating actual records processed.
OUTPUT RESET EOD? Y/N	(Entry allowed only after specification of OUT fields) Key Y for Yes or N for No.	If OUT DEV TYP is 'F' or 'D', cursor advances to this field after VOL NAME is entered. N/A if DEV TYP is 'T', 'C' or 'P'.

EXAMPLE:

Assume that 02 has been specified as the number of Data Sets to be INPUT, and the name of the first Data Set is designated as DATAFILE using DEVICES function of MEDIAU. When Data Transcription function of MEDIAU is selected subsequently, the system will change the 7th and 8th byte of the Data Set name to the numeric characters '01', so that DATAF01 is displayed as INP DATASET NAME. Then, when that Data Set has been transcribed, and the message 'END OF MEDIUM' is acknowledged by pressing RESET, the system will search for a Data Set in sequence — that is, DATAF02.

Thus, if INPUT of multiple Data Sets is planned, the sequence of INPUTS may be pre-determined and set up for "semi-automatic" operation by changing the Data Set Names to a series, such as:

```
dddddd01  
dddddd02  
dddddd03  
etc.
```

DSKETTEU or the utilities function of FDE may be used to change Data Set Names.

NOTE:

Transcription to multiple OUTPUT files may be set up in the same manner, enabling "semi-automatic" operation. In this case Data Sets that will receive data may be renamed dddddd01, ..., 02, etc., and the system will automatically search for the next data set in sequence after the message 'END OF MEDIUM' is acknowledged by pressing RESET.

3. Key the INP fields as required to designate data set(s) to be INPUT in Data Transcription operation using MEDIAU. Specified data set(s) will become defaults for these fields when one of the Data Transcription functions (COPY, PRINT, DISPLAY or DUMP) is selected from the MEDIAU Function Selection Display.

When INP specification is complete, cursor advances to the first position of the OUT field.

4. Key the OUT fields as required to designate data set(s)/device to be OUTPUT in Data Transcription operation using MEDIAU. Specified data set(s)/device become defaults for these fields when one of the Data Transcription functions is selected from the MEDIAU Function Selection Display.

When OUT specification is complete, cursor advances to the OUTPUT RESET EOD? field. Key Y or N.

5. When keying is complete, press ENTER.

The system examines INPUT/OUTPUT designations for consistency. (See Table VIII-1.)

- a. If no inconsistency is found, the Function Selection Display is returned.
- b. If inconsistency is found, the message 'INCONSISTENT SELECTION' appears flashing on the display screen. Press RESET to acknowledge the message; return to step 3 to correct the I/O specifications.

Table VIII-1 Valid Input/Output Combinations

—Output—

DISKETTE	DISKETTE		DISK		TAPE	COMPCHAN	PRINTER
	X'FF'	D/S	X'FF'	D/S			
X'FF'	1	4	4	3	3	3	3
D/S	4	1	4	2	2	2	2
X'FF'	4	4	4	4			
D/S	3	3					
TAPE	3	3					
COMPCHAN	3	3					

- = Valid Combinations
- = Invalid Combinations

(Attempt will result in one of two error MESSAGES: 'NOT FOUND/NOT AVAILABLE' or 'INCONSISTENT SELECTION'.)

- 1 = Valid; deleted records are transcribed and marked.
- 2 = Valid; deleted records are not transcribed.
- 3 = Valid; all records are transcribed and not marked.
- 4 = INCONSISTENT.

—Input—

DATA TRANSCRIPTION

— COPY, DISPLAY, PRINT, DUMP —

Four functions of MEDIAU may be used for various data transcription operations: COPY, DISPLAY, PRINT, and DUMP. Selection of one of these functions enables the transfer of a data file from one medium (device) to another, with or without transformation of data involved (see Table VIII-2, following).

Table VIII-2 Data Transcription Using MEDIAU

FUNCTION	KEY SEL	USES	NOTES AND LIMITATIONS
COPY	1	"Literal" transcription of data for duplication or unformatted list purposes.	Up to 99 Data Sets can be combined in a single COPY operation.
DISPLAY	2	Transcription of input file records to display on Operator Display screen.	160 characters of the input record can be displayed at one time. Keyboard control keys are used to advance through input file and perform other adjustments to the displayed data.
PRINT	3	Decompression of printer-destined records that exist in compressed format and creation of formatted list on printer.	Print parameters are ordinarily contained in the compressed data received in a separate operation via BSC COMM.
DUMP	4	Transformation of each input file record into equivalent hexadecimal records; transcription of these records to printer.	Records up to 512 characters; output must be printer.

DATA TRANSCRIPTION OPERATIONS USING MEDIAU

Consult Table VIII-2 to determine appropriate MEDIAU function to select (COPY, DISPLAY, PRINT, or DUMP).

BEFORE YOU START

- Controller Console power must be On.
- Operator Station power must be On.
- MDS Media Utilities program (MEDIAU) must be loaded from your Operator Station; if not, see PROGRAM LOAD section.
- Use DEVICES function of MEDIAU to specify I/O data sets (devices); ready peripheral devices (see PERIPHERALS section).

1. If the Function Selection Display is present on the Display Screen, go to Step 2; if not, press SEL MODE.

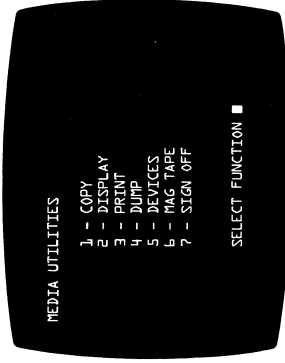

Function Selection Display

2. Select desired function. If 1—COPY, 3—PRINT, or 4—DUMP is selected, the following display will appear. If 2—DISPLAY is selected, go to Step 3.

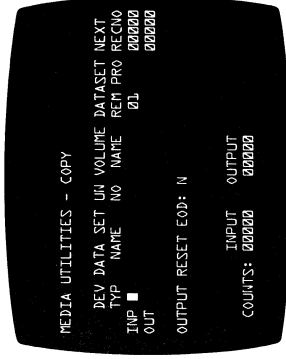

NOTE:

The function selected is designated following MEDIA UTILITIES at the top of the display.

- a. If I/O specifications have previously been made using the DEVICES function, operation will begin. Proceed to Step 4 on page 12.
- b. If I/O specifications have *not* been made previously, the cursor will appear in the DEV TYP column of the INP field, to enable keying desired INPUT and OUTPUT.

Step 2, continued

1. Key DEV TYPE, DATASET NAME, UN NO, VOL NAME, DATASET REM as required for INP field. (A description of I/O fields and appropriate entries is given in the DEVICE CONTROL subsection, foregoing.)
2. Repeat procedure for OUT field. Key Y or N in response to the OUTPUT RESET EOD? prompt.
3. Press ENTER.
4. The system searches for the designated I/O and checks for consistency of I/O specifications.
 - If the message 'XXX NOT FOUND/AVAIL' ('XXX' = DEV TYP) is presented, the system has been unable to locate either INP or OUT specified. Press RESET key to acknowledge message, and the cursor is moved to the DEV TYP column for rekeying INP or OUT (or both) specifications.
 - If the message 'INCONSISTENT SELECTION' is presented, the system has determined that INP and OUT specifications are inconsistent. (Refer to Table VIII-1 for valid Input/Output combinations.) Press RESET key to acknowledge the message; the cursor returns to the DEV TYP column of INP so that entry may be corrected.

3. If 2 — DISPLAY is selected from the Function Selection Display, the following display will appear:

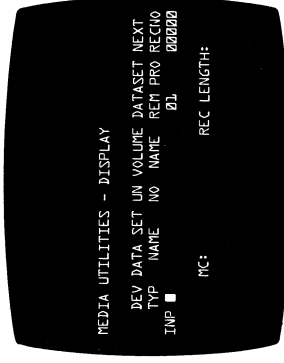

- a. If INPUT has not previously been designated using the DEVICES function of MEDIAU, the program defaults to I/O selection.

To designate INPUT, follow procedures given in Step 2.b., INP only. Once INP specification has been accepted, operation will begin.

NOTE:

Only one dataset can be accessed during DISPLAY function.

- b. If INPUT has previously been specified using DEVICES function of MEDIAU, the first 160 characters of the record designated as INP are displayed on lines 9, 10, 11, and 12 of the display screen, as in this example:

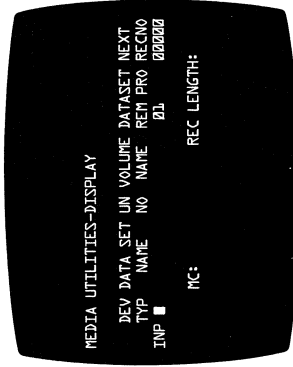

Information about the record displayed is given on line 7 of the display, as follows:

- ppp: indicates relative position, starting with '001' within input record of the first character displayed.
- X: position is normally blank, but contains an asterisk (*) if the record being displayed is in a data set marked as deleted.

MC:hh

'MC:' remains on the display; the numerals represented by the 'hh' are the hexadecimal representation of the first character displayed in line 9.

REC

LENGTH: 'nnn' is replaced by numerals indicating length of record being displayed.

C₁,C₂...

represents character number 1, character number 2, etc. of the record being inputted.

- c. The following control keys may be used to position the records being displayed:

Key

Effect of Single Depression:



The next record is read from the INPUT file and displayed; the position field is reset to '001'.



One is added to the position field, and the display is adjusted accordingly.



One is subtracted from the position field, and the display is adjusted accordingly.



The position field is adjusted to contain the next larger multiple of 10 relative to its current value, and the display is adjusted accordingly.

Key Effect of Single Depression:

The position field is adjusted to contain the next smaller multiple of 10 relative to its current value, and the display is adjusted accordingly.

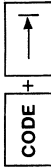

The position field is adjusted to contain the next larger multiple of 100 relative to its current value, and the display is adjusted accordingly.

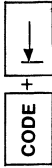

The position field is adjusted to contain the next smaller multiple of 100 relative to its current value, and the display is adjusted accordingly.

d. To end DISPLAY operation, either:

- use Control Keys to progress through INPUT file to EOF (End of File) and receive the message 'FUNCTION COMPLETE:'

OR

- press SEL MODE to return the Function Selection Display, thus terminating the DISPLAY operation.

4. During Data Transcription operation using COPY, PRINT or DUMP functions, the following display remains on the display screen with the INP/OUT specifications filled in:

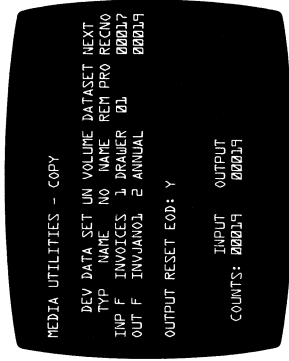

Progress of transcription operation may be monitored by observing as the counts on lines 5, 6 and 12 of the display increment and decrement, as follows:

DATA SET PRO: Remains blank until first Data Set is processed, then increments by 1.
(Line 5)

NEXT REC NO: Increments as records in INPUT file are transcribed into memory; is reset to zero if more than one Data Set is INPUT in operation.
(Line 5)

DATA SET PRO: Increments by 1 as each transcription of data set to OUTPUT is completed (for COPY operation only; field is not used if PRINT or DUMP).
(Line 6)

NEXT REC NO:
(Line 6)

Increments as actual records (including those marked deleted) in memory are transcribed to OUTPUT data set (device).

INPUT:
(Line 12)

Increments, counting all INPUT records in operation (not including deleted records - see TABLE VIII-1); is not reset to zero except at outset of operation.

OUTPUT:
(Line 12)

Increments, counting all OUTPUT records in operation (not including deleted records - see TABLE VIII-1); is not reset to zero except at outset of operation.

- The message 'NOT FOUND/AVAIL' will appear if DATASET REM is 01 and system cannot find the next Data Set Name in sequence. (See explanation of REM field in DEVICES subsection.) Press RESET key to acknowledge the message. The cursor is positioned in the DEV TYP column of the INP field to enable entry of desired Data Set Name.
 - The message (XXX) END OF MEDIUM, where XXX = device type, will appear if end of OUTPUT file is reached prior to completion of processing of INPUT. Press RESET key to acknowledge the message. The cursor is positioned in the DEV TYP column of the OUT field to enable entry of desired OUTPUT.
- c.
- a. When the message "FUNCTION COMPLETE" is presented, indicating successful completion of Data Transcription operation, press SEL MODE. The MEDIAU Function Selection Display returns.
 - b. Operation may be halted by the system due to one of the following conditions (see also list of STATUS/ ERROR MESSAGES at end of this section).
 - a. To prematurely discontinue operation, press SEL MODE. The MEDIAU Function Selection Display returns.
 - b. Operation may be halted by the system due to one of the following conditions (see also list of STATUS/ ERROR MESSAGES at end of this section).

MAGNETIC TAPE UTILITIES

The Magnetic Tape function of MEDIAU enables various utility operations pertinent to magnetic tape file delineation and positioning, using the keyboard of a Series 21 system Operator Station. The operations include:

- forward and reverse file skip
- forward and reverse record skip
- rewind and rewind lock
- tape mark generation
- forward skip to end of volume

NOTE:

If Data-Recorder is being used instead of Mag Tape Drive, turn to PERIPHERALS section, Data-Recorder subsection. Procedures given for Data-Recorder must be used instead of MEDIAU Mag Tape function procedures.

BEFORE YOU START:

- **Controller Console power must be On.**
 - **Operator Station power must be On.**
 - **MDS Media Utilities (MEDIAU) must be loaded from your Operator Station; if not, see PROGRAM LOAD.**
 - **Ensure that Tape Drive is ready; if not, see PERIPHERALS.**
1. If the Function Selection Display is displayed, go to Step 2; if not, press SEL MODE.

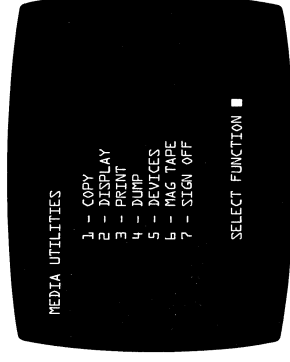

MEDIAU Function Selection Display

2. Select 6 — MAG TAPE. The following display will appear:

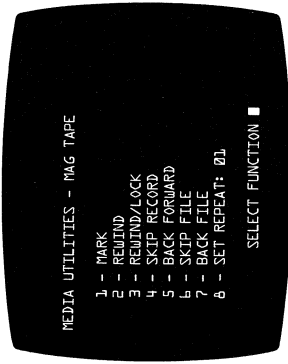

Tape Function Selection Display

3. If operation will involve repetitions of the same Tape Function, select 8 — SET REPEAT from the Tape Function Selection Display. This positions the cursor at the beginning of that two-character field. Initial value is set at 01 by the system.
 - a. If a single, non-repetitive function is to be performed, press ENTER. Proceed to Step 4.
 - b. If repetitive functions are required, key the number of repetitions desired (range is 01-99). Press ENTER. Note that the field will decrement as repetitive functions are performed.

4. Proceed with selection of Tape Function from display. The result of selecting functions 1 – 7 are shown below.
5. When SET REPEAT reaches zero, another Tape Function may be selected, or the MEDIAU Function Selection Display returned by pressing SEL MODE.

SELECTION	RESULT
1—MARK	A tape mark, tape mark, backspace sequence is performed.
2—REWIND	A tape rewind operation is initiated. Tape is positioned at load point (BOT) and in a ready state.
3—REWIND/LOCK	A tape rewind with lock operation is initiated.
4—SKIP RECORD	A tape record forward operation is performed. If EOF is detected the exception is noted on the screen. Tape Function Selection Display is returned.
5—BACK RECORD	A tape record backspace operation is performed.

SELECTION	RESULT								
6—SKIP FILE	The tape is moved forward until a tape mark is detected. Status distinguishing an initial tape mark from a non-initial tape mark is returned to allow detection of EOF.*								
7—BACK FILE	Action is as follows, depending on initial position of read mechanisms. <table border="1" style="width: 100%; margin-top: 5px;"> <thead> <tr> <th>POSITION</th> <th>ACTION</th> </tr> </thead> <tbody> <tr> <td>1. At first record.</td> <td>None.</td> </tr> <tr> <td>2. Immediately following a TM.</td> <td>Backspace, then backfile.</td> </tr> <tr> <td>3. Not immediately following a TM.</td> <td>Position following next preceding TM.</td> </tr> </tbody> </table>	POSITION	ACTION	1. At first record.	None.	2. Immediately following a TM.	Backspace, then backfile.	3. Not immediately following a TM.	Position following next preceding TM.
POSITION	ACTION								
1. At first record.	None.								
2. Immediately following a TM.	Backspace, then backfile.								
3. Not immediately following a TM.	Position following next preceding TM.								

* In case of repetitive function for 6—SKIP FILE, the sequence of file skips is terminated when two consecutive tape marks are detected and End of Volume (EOV) message is received.

DATA MANAGEMENT UTILITY

The MDS Data Management Utilities program for Series 21 provides sort, merge and index functions for data stored on diskette or disk and the option of reusing data set selection and key field parameters.

INTRODUCTION

The Data Management Utilities program (DMU) is supplied by MDS on a Library Diskette. It contains the following functions:

- SORT is used to arrange existing data set records in either ascending or descending order.
- MERGE is used to combine data set records from two previously sorted files into a single file.
- INDEX functions are 1) SEQUENTIAL INDEX, to produce sequentially sorted index pointers used to reference a data set's records by key field definitions, 2) RANDOM INDEX, used to produce index pointers from unsorted key field positions continued in data set record and 3) FORMAT RANDOM INDEX, used to prepare an index file for future use of a user-prepared MOBOL program.

NOTE:

Error and Status messages that may be received during operation of DMU are documented in MDS publication M-3925, *Series 21 Display Message Manual* for Rel. 7.0.

The following subsections provide detailed procedures for each function contained in the MDS Data Management Utilities program:

Title	Page
INTRODUCTION	1
SORT	2
MERGE	6
SEQUENTIAL INDEX	9
RANDOM INDEX	11
FORMAT RANDOM INDEX	13
PARAMETERS	15

SORT

BEFORE YOU START:

- Controller Console power must be On.
- Operator Station power must be On.
- MDS Data Management Utilities program (DMU) must be loaded from your Operator Station; if not, see PROGRAM LOAD section of this book.
- If diskette is to be used as OUTPUT, a data set with space at least equal to INPUT must be pre-defined and allocated.
- If disk is to be OUTPUT, sufficient space must be available.
- Data sets to be used as working areas (WORK A and WORK B) must be allocated before SORT operation can begin.

NOTE:

A Job Definition Keying Form should be prepared for the data set records to be sorted, in order to determine the key fields, the length of each, and the starting location of each field relative to the first character in the record.

1. If the DMU Function Selection Display is displayed, go to Step 2; if not, press SEL MODE.

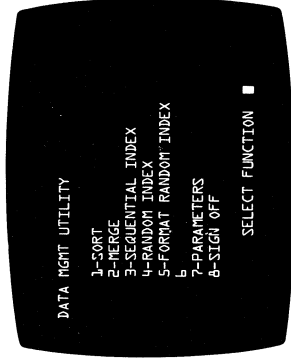

DMU Function Selection Display

2. Key 1 — SORT. Replace the MDS Library Diskette with diskette(s) containing the INPUT and OUTPUT data sets, and the data sets that will serve as WORK A and WORK B.

NOTE:

Data Sets for OUTPUT should be allocated at least as much space as the INPUT data set(s). Otherwise, multiple output data set can be used.

The WORK A/WORK B data sets must have a record length equal to 128 and can be allocated any number of sectors. Use FDE Utilities function, DSKETTEU or DISKU to allocate necessary data sets.

3. The following display will be presented:

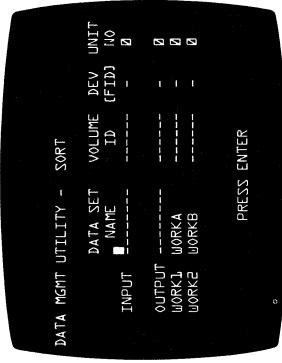

- a. Enter the Data Set Name, designate Device (F = diskette, D = disk), and enter Unit No. for both INPUT and OUTPUT data sets. (Entry of Volume ID is optional).

NOTE:

If DEV TYP is D, Unit No. defaults to '1'.

- b. Enter the Device (F or D) and Unit No. for the WORK A/WORK B fields. (Entry of Volume ID is optional.)
 - c. Press ENTER.
4. The following display is presented.

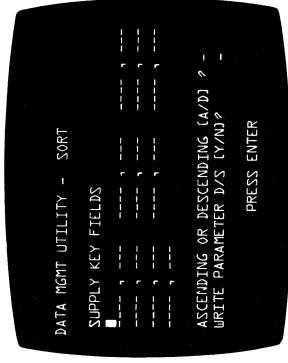

- a. Enter the KEY FIELD information. Press PROG ADV to skip key fields not needed for your operation.
- b. Select ASCENDING or DESCENDING (A or D).

c. Select Y for Yes or N for No in response to the WRITE PARAMETERS D/S prompt. (Y if data set selection and key field parameters are to be reused, N if not. If Y, see PARAMETERS subsection.)

d. Press ENTER.

5. The following display, with the message 'READING INPUT' appears.

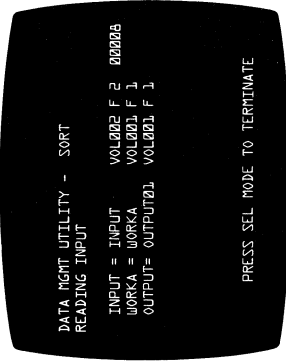

(As indicated on the display, press SEL MODE if you wish to terminate the sorting process at any point.)

6. When the system has reached the end of the INPUT file, the following message will be added to the display:

CODE/ENTER for more INPUT
or ENTER for no more INPUT.

a. If additional Data Sets are to be read as INPUT, ensure that media containing 2nd, 3rd, . . . nth INPUT data sets is in the drive originally designated for INPUT; the units position of the data set name (DATA 1, DATA 2, etc.) must be incremented by 1 for each additional INPUT. When next INPUT data set is readied according to these requirements, press code/ENTER. Return to Step 3.

b. If no more Data Sets are to be read as INPUT, press ENTER. Proceed to Step 7.

7. The message 'SORTING KEYS' indicates that records are being sorted. WORK A is added to the display, together with VOLID, DEV TYP and UNO supplied by the program; the RECORD COUNT field is incremented to indicate progress.

The message 'WRITING SORTED RECORDS' indicates that sorted records are being written to the OUPUT data set. When this message appears, observe as the number of OUTPUT records increments.

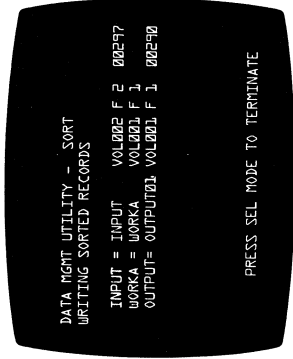

8. The message 'FUNCTION COMPLETE' flashes on and off to indicate completion of the SORT operation. Acknowledge message by pressing RESET.
9. The Function Selection Display returns. Select another function or 8 — SIGN OFF.

MERGE

BEFORE YOU START:

- **Controller Console power must be On.**
 - **Operator Station power must be On.**
 - **MDS Data Management Utility program (DMU) must be loaded from your Operator Station; if not, see PROGRAM LOAD.**
 - **If diskette is to be used as OUTPUT, a data set with space at least equal to INPUT must be pre-defined and allocated. If disk is to be OUTPUT, sufficient space must be available.**
1. If the DMU Function Selection Display is displayed, go to Step 2; if it is not displayed, press SEL MODE.

**Function Selection Display**

2. **Key 2 — MERGE.** Replace the MDS Library Diskette with diskette(s) containing the INPUT and OUTPUT data sets.
- NOTE:**
- The space allocated for OUTPUT should at least be equal to that of the combined INPUT data sets, otherwise the use of multiple output data sets is required.
3. The following display appears.



- a. Enter the Data Set Name, designate Device (F = diskette, D = disk), and enter Unit No. for INPUT and OUTPUT data sets. (Entry of Volume ID is optional.)
- b. Press ENTER.

4. The following display appears.

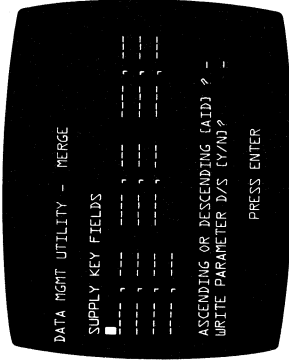

5. The following display appears in response if write parameters D/S: N.

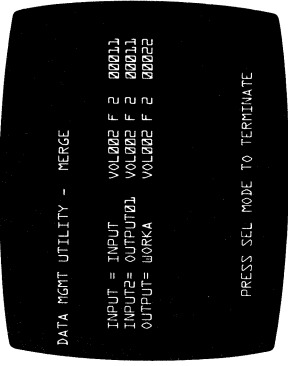

- a. Enter the KEY FIELD information. Press PROG ADV to skip key fields not needed for your operation.
- b. Select ASCENDING or DESCENDING (A or D).
- c. Select Y for Yes or N for No in response to the WRITE PARAMETERS D/S prompt. (Y if data set selection and key field parameters are to be reused, N if not. If Y, see PARAMETERS subsection.)
- d. Press ENTER.

When the INPUT records have been read, the following instruction will be added to the display:

CODE/ENTER for more INPUT
or ENTER for no more INPUT.

- a. If additional Data Sets are to be read as INPUT, ensure that media containing 2nd, 3rd, ..., nth INPUT data sets is in the drive originally designated for INPUT; the units position of the data set name (DATA 1, DATA 2, etc.) must be incremented by 1 for each additional INPUT. When next INPUT data set is read according to these requirements, press CODE/ENTER. Return to Step 3.

Merge, continued

- b. If no more Data Sets are to be read as INPUT, press ENTER.
6. The message 'FUNCTION COMPLETE' will flash on and off when the MERGE operation is completed. Press RESET to acknowledge the message, and the DMU Function Selection Display will appear.
7. Select another function or 8 — SIGN OFF.

SEQUENTIAL INDEX

BEFORE YOU BEGIN:

- Controller Console power must be On.
- Operator Station power must be On.
- MDS Data Management Utility program (DMU) must be loaded from your Operator Station; if not, see PROGRAM LOAD.
- If diskette is to be used as OUPUT, a data set with approximately 10% more space than INPUT must be pre-defined and allocated. If disk is to be OUTPUT, sufficient space must be available.
- The data set used as a working area (named WORK A) must be allocated with at least as many records as INPUT or reside on DISK before SEQUENTIAL INDEX operation can begin.

1. If the DMU Function Selection Display is displayed, go to Step 2; if not, press SEL MODE.



DMU Function Selection Display

2. Key 3 — SEQUENTIAL INDEX. Replace the MDS Library Diskette with diskette(s) containing the INPUT and OUTPUT data sets.

- The following display appears.

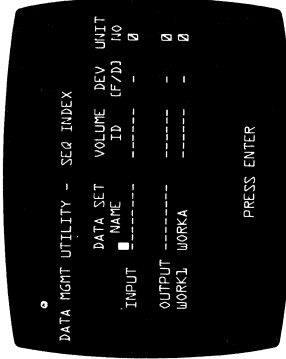

- The following display appears:

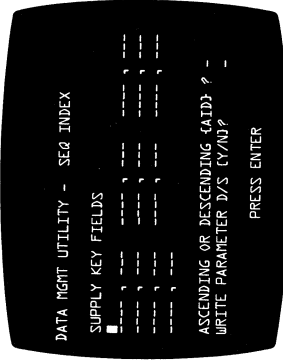

- Enter the Data Set Name, designate Device (F = diskette, D = disk), and enter Unit No. for INPUT and OUTPUT data sets. (Entry of Volume ID is optional.)
- Enter Device and Unit No. for data set named WORK A.
- Press ENTER.

- Enter the KEY FIELD information. Press PROG ADV to skip key fields not needed for your operation.
 - Select ASCENDING or DESCENDING (A or D).
 - Select Y for Yes or N for No in response to the WRITE PARAMETERS prompt. (Y if data set selection and key field parameters are to be reused, N if not. If Y, see PARAMETERS subsection.)
 - Press ENTER.
- When the message FUNCTION COMPLETE appears, press RESET to acknowledge. The DMU Function Selection Display will appear. Select another function or 8 — SIGN OFF.

RANDOM INDEX

BEFORE YOU BEGIN:

- **Controller Console power must be On.**
- **Operator Station power must be On.**
- **MDS Data Management Utility program (DMU) must be loaded from your Operator Station; if not, see PROGRAM LOAD.**
- **If diskette is to be used as OUTPUT, a data set with approximately 10% more space than INPUT must be pre-defined and allocated. If disk is to be OUTPUT, sufficient space must be available.**

If the DMU Function Selection Display is displayed, go to Step 2; if not, press SEL MODE.

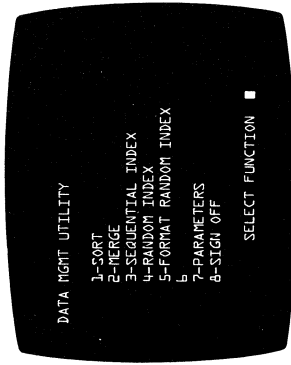

DMU Function Selection Display

2. Key 4 — RANDOM INDEX. Replace the MDS Library Diskette with diskette(s) containing the INPUT and OUTPUT data sets.
3. The following display appears:

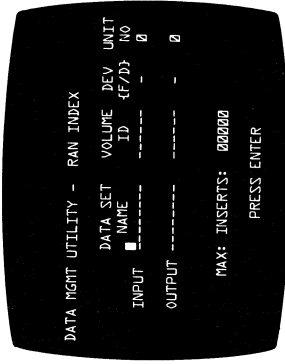

- a. Enter the Data Set Name, designate Device (F = diskette, D = disk), and enter Unit No. for INPUT and OUTPUT data sets. (Entry of Volume ID is optional.)
- b. Enter the maximum number of records to be inserted in the INPUT (target) data set prior to regenerating RANDOM INDEX in response to the MAX. INSERTS prompt. (1-99999).
- c. Press ENTER.

- The following display appears.

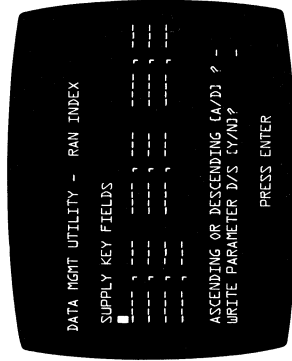

- Enter KEY FIELD information. Press PROG ADV to skip key fields not needed for your operation.
- Select Y for Yes and N for No in response to the WRITE PARAMETERS prompt. (Y if data set selection and key field parameters are to be reused, N if not. If Y, see PARAMETERS subsection.)
- Press ENTER.

NOTE:

No ASCENDING/DESCENDING prompt is available for RANDOM INDEX.

- When the message FUNCTION COMPLETE appears, press RESET to acknowledge. The DMU Function Selection Display appears. Select another function or 8 — SIGN OFF.

FORMAT RANDOM INDEX

BEFORE YOU BEGIN

- **Controller Console power must be On.**
 - **Operator Station power must be On.**
 - **MDS Data Management Utility program (DMU) must be loaded from your Operator Station; if not, see PROGRAM LOAD.**
 - **If diskette is to be used as OUTPUT, a data set with approximately 10% more space than INPUT must be pre-defined and allocated. If disk is to be OUTPUT, sufficient space must be available.**
1. If the DMU Function Selection Display is displayed, go to Step 2; if not, press SEL MODE.

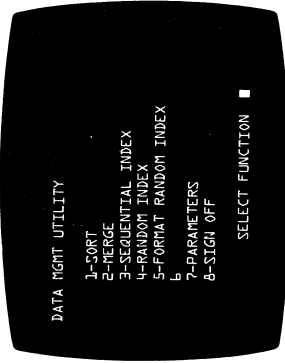

DMU Function Selection Display

Format Random Index

2. Key 5 — FORMAT RANDOM INDEX. Replace the MDS Library Diskette with diskette(s) containing the INPUT and OUTPUT data sets.
3. The following display appears:

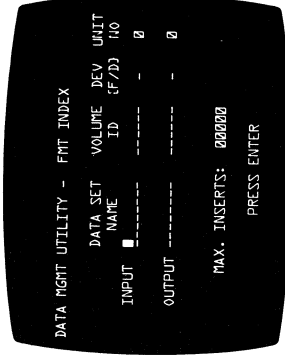

- a. Enter the Data Set Name, designate Device (F = diskette, D = disk), and enter Unit No. for INPUT and OUTPUT data sets, (Entry of Volume ID is optional).
- b. Enter the number of records to be inserted in response to the MAX. INSERTS prompt (1-99999).
- c. Press ENTER.

PARAMETERS

BEFORE YOU BEGIN

- **Controller Console power must be On.**
- **Operator Station power must be On.**
- **MDS Management Utility program (DMU) must be loaded from your operator station; if not, see PROGRAM LOAD.**
- **Ensure that a Data Set is allocated in which PARAMETERS will be stored.**

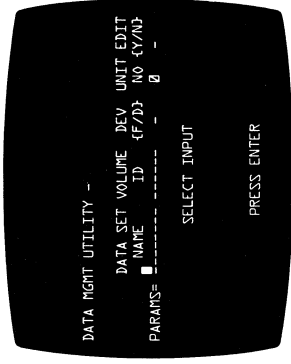

1. If the DMU Function Selection Display is displayed, go to Step 2; if not, press SEL MODE.
 2. Key 7 — PARAMETERS. Replace the MDS Library Diskette with the diskette containing the data set on which parameters created using other DMU functions (SORT, MERGE, SEQ INDEX, RAN INDEX, FMT INDEX) have been stored.
 3. The following display will appear.
NOTE:
This display appears during use of other DMU functions if Y is the response to the WRITE PARAMETERS prompt following entry of KEY FIELD information.
- a. Enter the Data Set Name, Device (F or D) and Unit No. fields; enter Y for Yes or N for No in response to the EDIT (Y/N) prompt.
If Y, make necessary changes in the two displays that follow. Reuse (edited) data set selection and key field parameters.
If N, reuse existing data set selection and key field parameters.
b. Press ENTER.
4. The DMU Function Selection Display returns. Refer to appropriate subsection for procedures (SORT, MERGE, SEQ INDEX, RAN INDEX, AND FMT INDEX). Proceed with operation accordingly.

DISKETTE UTILITIES PROGRAM

INTRODUCTION

The MDS-supplied Diskette Utilities program (DSKETTEU) provides functions for Volume and Data Set labeling and allocation/deallocation of space on diskette. DSKETTEU may also be used to scan through the sequence of Data Set labels resident on diskette.

NOTE:

Additional information about terms and concepts may be found in the INTRODUCTION, DISKETTE ORGANIZATION and GLOSSARY sections of this book, and in the following MDS publications:

Series 21 Utilities Reference Manual, M-3924
Series 21 Display Messages Manual, M-3925

DSKETTEU functions include:

- Initialization of new diskettes (used to "scratch" previously used diskette)
- Volume labeling
- Data Set labeling

The procedures in this section are organized as follows:

TITLE	PAGE
INTRODUCTION	1
DSKETTEU FUNCTION SELECT	2
VOLUME LABEL FUNCTIONS	4-8
Diskette Initialization	5
Volume Naming	7
Designating Volume Accessibility	8
DATA SET LABEL FUNCTIONS	11-20
Creating Data Set Label	11
Reorganization of Space on Diskette	14
Table X-1, Description of Fields on Data Set Label Display	21

DSKETTEU FUNCTION SELECT

BEFORE YOU BEGIN:

- Controller Console power must be ON.
- Operator Station power must be ON.
- MDS Diskette Utilities program (DSKETTEU) must be loaded from your operator station; if not, see PROGRAM LOAD section of this publication.
- Have ready the diskette(s) requiring Volume or Data Set labeling functions.

1. When DSKETTEU is loaded, the following display is presented:

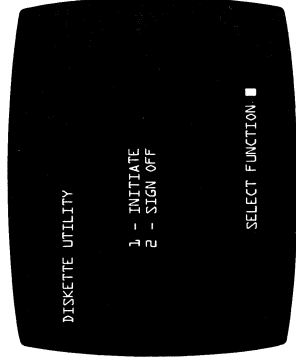

Function Select Display

- Any error/status messages presented during operation of DSKETTEU functions are acknowledged by pressing the RESET key. See MDS publication M-3925, *Series 21 Display Messages Manual* for detailed information.
 - When DSKETTEU Function Select Display is present, the Library Diskette may be removed. The diskette drive is thus freed for insertion of the diskette requiring Volume or Data Set labeling.
2. Select desired function as follows:
- Key '1' to proceed with use of any DSKETTEU function.
Key '2' to SIGN OFF. The System Select Menu Display is returned.

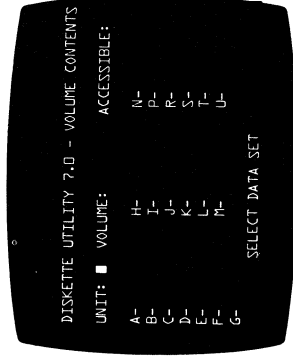

Software Release level

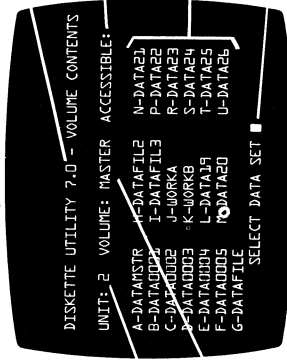

Number of designated diskette drive
6-character Volume name

1 - character field: if blank, volume is accessible.

Menu of Data Set names for which labels exist in VTOC

cursor

DISKETTE Unit Select Display

3. a. Insert diskette requiring Volume/Data Set label operation(s) in diskette drive.
- b. Number (1 - 4) of diskette drive must be keyed in the UNIT: field.

The program reads the Volume Table of Contents (VTOC) of the diskette in the designated unit, and displays the contents of the existing Volume Label, as in the following example:

Typical Volume Table Of Contents

4. Use procedures given in VOLUME LABEL FUNCTIONS, following, for Diskette Initialization, Volume naming, and designing Volume accessibility.

Use procedures given in DATA SET LABEL FUNCTIONS (following the VOLUME LABEL FUNCTIONS subsection) for Data Set label creation/modification and reorganization of space on diskette.

VOLUME LABEL FUNCTIONS

1. The details of the current Volume Label are shown on the display screen, as in the following example:
 - Diskette Initialization (to “scratch” a previously used diskette)
 - Volume naming
 - Designating Volume accessibility
2. The following Volume Functions may be performed using procedures found in this subsection:

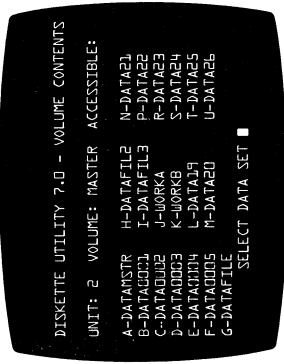

DISKETTE INITIALIZATION

NOTE:

Initialization process results in format that meets Basic Data Exchange requirements.

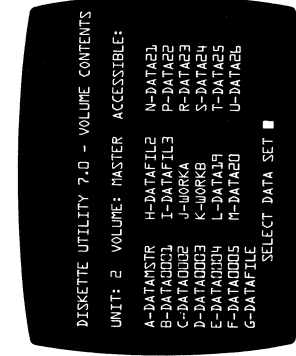

Typical Volume Table Of Contents

Step 1. Press HOME key once to move cursor to the UNIT: field.

IMPORTANT:

Ensure that UNIT # has been specified correctly, and that the VTOC displayed is the one to be initialized.

Step 2. Hold CODE key down and press HOME key.

Volume Functions, continued

Step 3. The message 'INITIALIZING VOLUME' is presented as the program re-formats the volume, and then presents the following display:

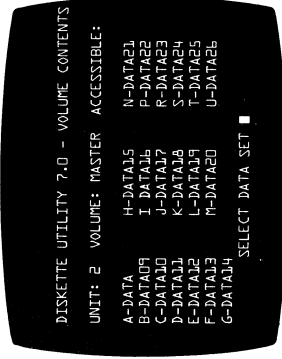

Volume Contents Display Of Newly Initialized Diskette

NOTE THE FOLLOWING HAS OCCURRED:

- The number shown in UNIT: field is the diskette drive containing the diskette that has been initialized.
- The 6-character name in the VOLUME: field is the Volume Name of the diskette, which is not changed by the initialization process.

- c. The ACCESSIBILITY field is blank.
 - d. 19 Data Set Names have been assigned as shown, creating entries in the Volume Table of Contents. Names may be changed using Data Set Label Creation procedures. (See DATA SET LABEL FUNCTIONS.)
 - e. Initialization has assigned all available space on the diskette to the first Data Set, named DATA. (See DATA SET LABEL FUNCTIONS subsection for allocation procedures.)
- Step 4. After completing Diskette Initialization, the following options are available.
- a. Proceed to Data Set Label operations by selecting desired Data Set Label,

OR

- b. Press SEL MODE to return to DSKETTEU Function
Select Display to SIGN OFF or re-INITIATE to re-use Volume Functions.

VOLUME NAMING

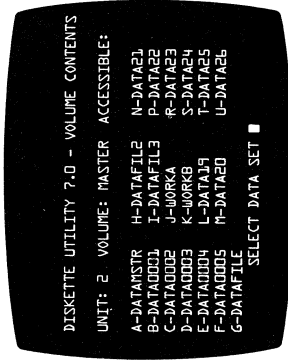

Typical Volume Table Of Contents

- Step 1. Press Field Backspace key (\leftarrow) twice to move cursor to the VOLUME field.
- Step 2. Key the desired 6-character name. Alphabetic and/or numeric characters may be used. For System Diskettes, the first three characters must be 'LIB'.

NOTE:

In case of keying error, use Character Backspace key (\leftarrow) or Field Backspace key (\leftarrow) to move cursor for rekeying.

- Step 3. Press ENTER when correct name is keyed.
The message 'FUNCTION COMPLETE' is presented, along with an audible tone to signal successful completion of the operation.
- Step 4. Press RESET key to acknowledge message. The cursor returns to the 'SELECT DATA SET' field.
- Step 5. After completing Volume Naming function, the following options are available.
 - a. Proceed to Data Set Label operations by selecting desired Data Set label.
 - OR
 - b. Press SEL MODE to return to DSKETTEU Function Select Display in order to SIGN OFF or re-INITIATE to re-use Volume Functions.

DESIGNATING VOLUME ACCESSIBILITY



Accessibility Field

Step 4. After designating Volume Accessibility, the following options are available:

- a. Proceed to Data Set Label operations by selecting desired Data Set label,
- OR
- b. Press SEL MODE to return to DSKETTEU Function Select Display in order to SIGN OFF or re-INITIATE to re-use Volume Functions.

Typical Volume Contents Display

- Step 1. Press Field Backspace key () once to move cursor to the ACCESSIBILITY field.
- Step 2. To make Volume ACCESSIBLE, key a space or press SKIP to blank the field.
To make Volume INACCESSIBLE, key any character.
The message 'FUNCTION COMPLETE' is presented, along with an audible tone to signal successful completion of modification of the field.
- Step 3. Press RESET key to acknowledge message. The cursor returns to the SELECT DATA SET field.

DATA SET LABEL FUNCTIONS

1. The details of the current Volume Label are shown in the display screen, as in the following example:

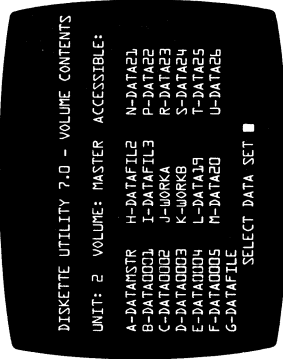

Typical Volume Contents Display

2. Key 'A' to read the information on the label of Data Set Number 01. The following display is presented, with the information filled in:

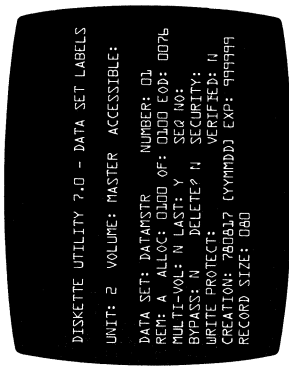

Typical Data Set Label Display

The following Data Set Label Functions may be performed using procedures found in this subsection:

- Data Set Label creation or modification
- Reorganization of space on diskette

NOTE:

Allocation of space on a newly initialized diskette using DSKETTEU must begin with Dataset Number 01, then Dataset 02, then Dataset 03, and so on.

3. After completing operations using any or all of the Data Set Label functions, the following options are available:

a. Return to Volume Contents display for this diskette by holding **CODE** down while pressing **SEL MODE**.

OR

b. Return to **DSKETTEU** Function Select Display by pressing **SEL MODE**, then **SIGN OFF**.

DATA SET LABEL CREATION

```
DISKETTE UTILITY 7.0 - DATA SET LABELS
UNIT: 2 VOLUME: MASTER ACCESSIBLE:
DATA SET: DATA NUMBER: 01
REH: A ALLOC: 1898 OF: 1898 EOF: 0000
MULTI-VOL: N LAST: Y SEQ NO:
BYPASS: N DELETE? N SECURITY:
WRITE PROTECT: (Y/N/M/D/J) VERIFIED: N
CREATION: (Y/N/M/D/J) EXP:
RECORD SIZE: 128
```

Data Set Label Display On Newly Initialized Diskette

NOTE:

All fields must be keyed as specified to meet Basic Data Exchange requirements.

Step 1. If newly initialized diskette, ALLOC: 1898 OF: 1898, as shown above.

Otherwise, use SCAN key to advance to next unallocated Data Set label, indicated by ALLOC: 0000 of 0000. Press Field Forward key (→) to move cursor to the ALLOC: field, and the program fills the OF: field with the number of sectors now available to this dataset. (Holding CODE key down while pressing SCAN key reverses direction of scanning.)

```
DISKETTE UTILITY 7.0 - DATA SET LABELS
UNIT: 2 VOLUME: MASTER ACCESSIBLE:
DATA SET: DATA NUMBER: 12
REH: A ALLOC: 0000 OF: 0578 EOF: 0000
MULTI-VOL: N LAST: Y SEQ NO:
BYPASS: N DELETE? Y SECURITY:
WRITE PROTECT: (Y/N/M/D/J) VERIFIED:
CREATION: (Y/N/M/D/J) EXP:
RECORD SIZE: 080
```

Step 2.

DATA SET: Key the desired Data Set Name using any 8 characters (excluding spaces) with the first character alphabetic.

Step 3.

ALLOC: Key number of sectors to be allocated to this Data Set. Value may not exceed the number shown in OF field.

Press EXIT key.

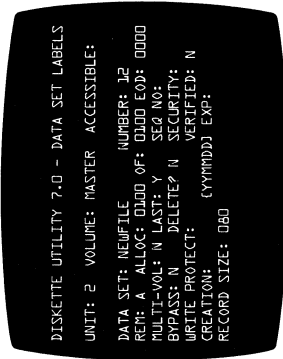
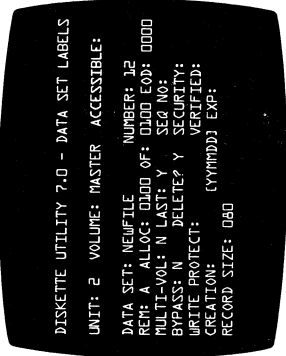

- Step 8. **BYPASS:** Key 'N'. Otherwise, if Data Set is to be bypassed in data transcription operations, key 'Y'.
- Step 9. **DELETE?** Key 'N' to indicate non-deleted label. Otherwise, key 'Y' if the Data Set is to be marked as deleted.
- Step 10. **SECURITY:** Key any character in the SECURITY: field if the Data Set is to be secured (read-protected and write-protected). Otherwise, use SKIP key.

Step 4. **EOD:** Key 'O' to indicate the number of the sector at which data is to begin and press EXIT. Alternately, EXIT key may be pressed to zero fill the field automatically.

Step 5. **MULTI-VOL:** If Data Set is not to be part of a Multi-Volume file, key 'N'. Otherwise, key 'Y'.

Step 6. **LAST:** If MULTI-VOL: N, key 'Y'.

Otherwise, if MULTI-VOL: Y, key 'N' or 'Y' to indicate whether this Data Set is the last one in the Multi-Volume file. (N = no, Y = yes)

Step 7. **SEQ NO:** If MULTI-VOL: N, press SKIP.

Otherwise, if MULTI-VOL: Y, key 2-digit number (01 - 99) to specify the sequence number of this Data Set in the Multi-Volume file.

Step 11. **WRITE PROTECT:** Key any character if the Data Set is to be write-protected. Otherwise, use SKIP key.

Step 12. **VERIFIED:** Key 'N' to indicate that data in Data Set has not been verified. Otherwise, key 'Y'.

Step 13. **CREATION:** Enter current date. Key numerals representing date as directed in the (YYMMDD) prompt immediately following the field:

EXAMPLE: 780515 = 1978 MAY 15.

Optionally, this field may be blank. Complete field by pressing **SKIP**.

Step 14. **EXP:** Enter expiration date of Data Set in **EXP** field. Use same order (YYMMDD) as for **CREATION** field.

Optionally this field may be blank. Complete field by pressing **SKIP**.

Step 15. **RECORD SIZE:** Key 3-digit number to specify the logical record size in the Data Set. Range is 001 – 128. Press **EXIT**.

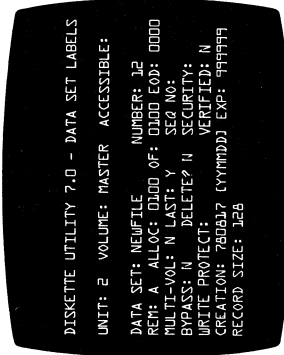

NOTE:

Original default values may be restored to the display by holding the **CODE** key down while pressing **RESET** key.

Step 16. Press **ENTER**.

Data Set label information, as keyed, is written to the **VTOC**. The cursor returns to the **DATA SET:** field. The data as keyed remains on the display for visual confirmation.

If corrections in any fields are needed, use **Field Forward** key (**→**) to advance to field and re-key. Press **ENTER** again.

Step 17. Options include the following:

1. Press **SCAN** to advance to the next Data Set label to allocate another Data Set.
2. Press **CODE/SEL MODE** to return the **VOLUME FUNCTIONS** display.
3. Press **SEL MODE** to return to **DSKETTEU Function** Select Display and select **SIGN OFF**.

REORGANIZATION OF SPACE ON DISKETTE

DSKETTEU functions enable reorganization of space after initial allocation of two or more data sets. This is desirable when unused sectors allocated to a data set are needed to expand a contiguous data set.

The unused sectors may be deallocated from their current assignment, and reassigned in either direction. This involves two distinctly separate steps: 1) deallocation, and 2) reassignment.

Reorganization of space is accomplished by setting the value of the REM: field on line 6 of the Data Set Label display.

The REM: field accepts either 'A' or 'B'. Content of the field determines the destination of sectors being deallocated, or the source of sectors being allocated, as follows:

A = AFTER currently displayed data set

B = BEFORE currently displayed data set

The initial layout of allocated data sets before space reorganization is shown below.

DATA SET 01	DATA SET 02	DATA SET 03
FILE01	FILE02 (UNUSED)	FILE03
100 SECTORS	100 SECTORS	100 SECTORS

REM: field

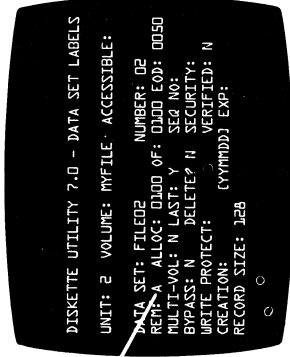

Typical Data Set Label Display

EXAMPLE A: Deallocation of sectors in DATA SET 02 with REM: B, and subsequent allocation of these sectors to DATA SET 01 with REM: A, will result in DATA SET 01 acquiring the space from DATA SET 02 as shown below. (See page 15.)

DATA SET 01	DATA SET 03
FILE01	FILE 03
200 SECTORS	100 SECTORS

EXAMPLE B: Deallocation of sectors in DATA SET 02 with REM: A, and subsequent allocation of these sectors to DATA SET 03 with REM: B, will result in DATA SET 03 acquiring the space from DATA SET 02 as shown below. (See page 17.)

DATA SET 01	DATA SET 02	DATA SET 03
FILE01		FILE03
100 SECTORS		200 SECTORS

EXAMPLE C: Deallocation of SOME of the sectors in DATA SET 02 with REM: A, and subsequent allocation of these sectors to DATA SET 03 with REM: B, will result in DATA SET 03 acquiring the sectors released from DATA SET 02 as shown below. (See page 19.)

DATA SET 01	DATA SET 02	DATA SET 03
FILE01	FILE02	FILE03
100 SECTORS	50 SECTORS	150 SECTORS

IMPORTANT:
Sectors must have been allocated before they can be deallocated for purposes of space reorganization.

EXAMPLE A: PROCEDURES

Step 1. Begin with the Volume Contents Display on screen.



Step 2. Select the data set from which sectors will be deallocated. The program presents the Data Set Labels display for the data set selected.

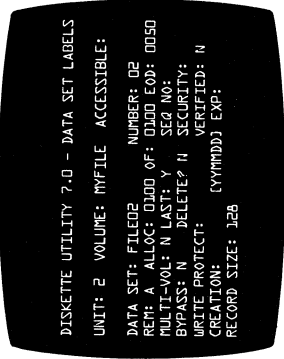

- Step 3. Read the information on the display to confirm that the label is the correct one.
- Step 4. Press Field Forward key (**→**) to advance to the ALLOC: field.
- Step 5. Press Field Backspace key (**←**) to enter the REM: field.
- Step 6. Key 'B' to specify that sectors are to be released to the data set immediately preceding the one displayed. The cursor moves to the ALLOC: field.
- Step 7. Deallocate the sectors shown in the ALLOC: field by pressing EXIT key. The cursor moves to the EOD: field.
- Step 8. Press EXIT key to zero the EOD: field.
- Step 9. Press ENTER.
- The cursor returns to the DATA SET: field, and the OF: field is zeroed by the program.
- Step 10. Hold CODE key down while pressing SCAN to back up to the data set label immediately preceding.
- Step 11. Press Field Forward key (**→**) to advance to the ALLOC: field.

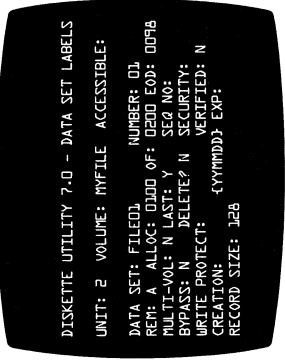

Notice that the sectors deallocated in previous Steps have been added to the OF: field of this Data Set label.

- Step 12. Key same value as is shown in the OF: field. Press EXIT key.
- Step 13. Press ENTER.
- Step 14. Options include the following:
- a. Moving sectors now allocated to this data set to the one preceding it, provided this is not DATA SET NUMBER 01, and if EOD: is 0000. Repeat Steps 1-13.
 - b. While positioned at Data Set label, make any appropriate changes to specifications in other fields. (See DATA SET LABEL CREATION.)

- c. Press CODE/SEL MODE to return to the Volume Contents Display.
- d. Press SEL MODE to return to the DSKETTEU Function Select Display.

EXAMPLE B: PROCEDURES

NOTE:

Sectors may not be appended to the DATA SET following if it contains valid data by having an EOD: value greater than 0000.

- Step 1. Begin with the Volume Contents Display on screen.

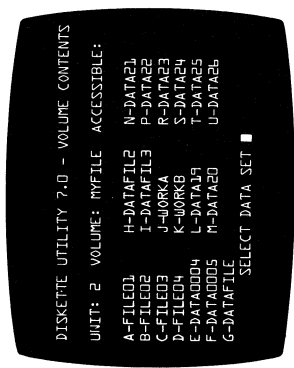

- Step 2. Select the data set from which sectors will be deallocated. The program returns the Data Set Labels display for the data set selected.

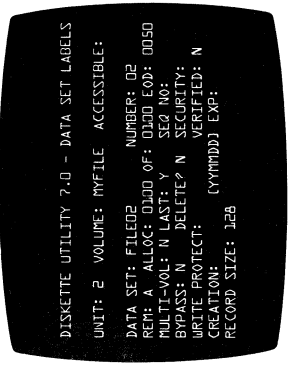

- Step 3. Read the information on the display to confirm that the label is the correct one.
- Step 4. Press Field Forward key (→) to advance to the ALLOC: field.
- Step 5. Deallocate all sectors by pressing EXIT key. The cursor moves to the EOD: field.
- Step 6. Press EXIT key to zero the EOD: field.
- Step 7. Press ENTER. The cursor returns to the DATA SET: field.
- Step 8. Ensure that ALLOC: and EOD: are '0000'.

Step 9. Press SCAN to advance to the next data set label.

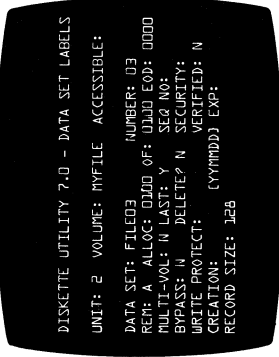

Step 10. Press Field Forward key (**→**) to advance to the ALLOC: field.

Step 11. Press Field Backspace key (**←**) to enter the REM: field.

Step 12. Key 'B' to indicate that sectors to be allocated are from before the currently displayed data set label. The cursor moves to the ALLOC: field.

NOTE:

After keying 'B', the value of the OF: field is increased by the number of sectors de-allocated in previous steps.

Step 13. Key number of sectors to be allocated to this Data Set in the ALLOC: field. Value may not exceed the number shown in the OF: field. Press EXIT. The cursor moves to the EOD: field.

Step 14. Press EXIT key to zero the EOD: field.

NOTE:

The message 'NON-EMPTY DATA SET' will be returned unless EOD: 0000.

Step 15. Press ENTER.

Cursor returns to DATA SET: field, and REM: field defaults to 'A'. ALLOC: field is as keyed in Step 13. EOD is zero.

Step 16. Options include the following:

- a. Move sectors now allocated to this Data Set to the one following it. Repeat steps 1 – 15.
- b. While positioned at Data Set label, make any appropriate changes to specifications in other fields. (See DATA SET LABEL CREATION.)
- c. Press CODE/SEL MODE to return to the Volume Contents Display.
- d. Press SEL MODE to return to the DSCKETTEU Function Select Display.

EXAMPLE C: PROCEDURES

NOTE:

Sectors may not be appended to the beginning of a data set if it contains valid data by having an EOD value greater than 0000.

Step 1. Same as for EXAMPLE B Steps 1 through 3. Ensure that the label displayed is the one from which sectors are to be deallocated (DATA SET 02 in the example given).

NOTE:

If deallocation is not necessary because the value in the OF: field is greater than the value in the ALLOC: field, proceed to Step 5.

```
DISKETTE UTILITY 7.0 - DATA SET LABELS
UNIT: 2 VOLUME: MYFILE ACCESSIBLE:
DATA SET: FILE02 NUMBER: 02
REM: A ALLOC: 0100 OF: 0100 EOD: 0050
MULTI-VOL: N LAST: Y SEQ NO:
BYPASS: N DELETE? N SECURITY:
WRITE PROTECT: (Y|N|DD) EXP:
CREATION:
RECORD SIZE: 128
```

Step 2. (Note that REM: A.) Press Field Forward key (\rightarrow) to advance to the ALLOC: FIELD.

Step 3. Key '0050' in the ALLOC: field.

NOTE:

Number keyed must be equal to or greater than the number in EOD; if existing data is to be retained.

Step 4. Press ENTER.

Step 5. Press SCAN key to advance to the next data set label.

```
DISKETTE UTILITY 7.0 - DATA SET LABELS
UNIT: 2 VOLUME: MYFILE ACCESSIBLE:
DATA SET: FILE03 NUMBER: 03
REM: A ALLOC: 0100 OF: 0100 EOD: 0000
MULTI-VOL: N LAST: Y SEQ NO:
BYPASS: N DELETE? N SECURITY:
WRITE PROTECT: (Y|N|DD) EXP:
CREATION:
RECORD SIZE: 128
```

Step 6. (Note that EOD = 0 in this example.) Press Field Forward key (\rightarrow) to advance cursor to the ALLOC: field.

Step 7. Press Field Backspace key (\leftarrow) to enter the REM: field.

Step 8. Key 'B' to indicate that sectors are to be appended to this data set at the beginning, and the physical source of these sectors is **BEFORE** the existing data set.

Note that after keying 'B', the value now in the OF: field is the sum of the sectors deallocated from the previous data set and the sectors currently allocated to this data set.

The cursor moves to the ALLOC: field.

Step 9. Key the number shown in the OF: field in the ALLOC: field. Press **EXIT**. The cursor moves to the EOD: field.

Step 10. Press **EXIT** to zero the EOD: field.

NOTE:

The message 'NON-EMPTY DATA SET' will be returned unless EOD: 0000.

Step 11. Press **ENTER**.

The cursor returns to the DATA SET: field, and the REM: field defaults to 'A'. The ALLOC: field is as keyed in Step 9, and the number in the OF: field now is the sum of the number shown in this field in Step 9, and the number of sectors originally available to this data set.

If the number in the OF: field is greater than that shown in the ALLOC: field, this data set may be further expanded (return to Step 9), or these sectors may be appended to the beginning of the next data set by pressing **SCAN** (return to Step 5).

Step 12. Options include the following:

- a. Move sectors now allocated to this Data Set to the one following it. Repeat Steps 1 – 11.
- b. While positioned at data set label, make any appropriate changes to specifications in other fields. (See DATA SET LABEL CREATION.)
- c. Press **CODE/SEL MODE** to return to the Volume Contents Display.
- d. Press **SEL MODE** to return to the DSKETTEU Function Select Display.

Table X-1 Description of Fields in Data Set Label Display

FIELD NAME	DEFAULT VALUE	ENTRY ALLOWED?	VALID ENTRY	EXPLANATION
UNIT:	(Variable)	N	—	Program provides number of diskette drive in which diskette containing specified Data Set is resident.
VOLUME:	(Variable)	N	—	Volume name of diskette. (Name may be changed using Volume Functions of DSKETTEU.)
ACCESSIBLE:	(Variable)	N	—	If field is blank, Volume is accessible; if any character is entered, Volume is not accessible. (May be changed using Volume Functions of DSKETTEU.)
DATA SET:	(As for initialized diskette)	Y*	Any eight-character	First character must be alphabetic. Excluding spaces, numerals may be keyed in addition to alphabetic characters.
NUMBER:	(As for initialized diskette)	N	—	Program supplies number of Data Set label (01–19) currently displayed.
REM:	A	Y	A or B	If REM: A, program is directed to allocate to or deallocate from the end of currently displayed Data Set. If REM: B, program is directed to allocate to or deallocate from the beginning of currently displayed Data Set.

*These fields on the Data Set Labels Display enable creating data set labels that meet requirements of Basic Data Exchange. For Series 21, these fields may or may not be interrogated.

Table X-1 Description of Fields in Data Set Label Display, continued

FIELD NAME	DEFAULT VALUE	ENTRY ALLOWED?	VALID ENTRY	EXPLANATION
ALLOC:	0000	Y	Numeric;	Size of number that can begining of currently displayed Data Set.
OF:	(Variable)	N	—	System supplies number of sectors available to the currently displayed Data Set label.
EOD:	0000	Y	Range is 0000 up to number in ALLOC; field	When creating new Data Set label, field may be keyed '0000' or zeroed using EXIT key. Usually set to 0000 for an empty data set.
MULTI-VOL:	N	Y*	Y or N	As data is keyed or copied into the data set, system increments the EOD: field to show number of next available sector. Enter Y if Data Set displayed is to be part of a related sequence of data sets; the next two fields are used to indicate the relative position of this data set in the sequence.
LAST:	Y	Y*	Y or N	Prompt asks if this Data Set is the last in a sequence. If not part of a sequence, key 'N'.
SEQ NO:	(blank)	Y	01 - 99	If MULTI-VOL: Y, field may be used to designate the number of this Data Set in the series.
BYPASS:	(blank)	Y	Y or N	Enter Y if Data Set should be bypassed in data transcription operations.

*These fields on the Data Set Labels Display enable creating data set labels that meet requirements of Basic Data Exchange. For Series 21, these fields may or may not be interrogated.

Table X-1 Description of Fields in Data Set Label Display, continued

FIELD NAME	DEFAULT VALUE	ENTRY ALLOWED?	VALID ENTRY	EXPLANATION
DELETE?	(As for initialized diskette)	Y	Y or N	Used to mark Data Set label deleted in VTOC.
SECURITY:	(blank)	Y	Any character	If any character is entered, Data Set is read-protected and write-protected; if left blank, Data Set is not secured.
WRITE-PROTECT:	(blank)	Y	Any character	If any character is entered, Data Set is write-protected; if left blank, Data Set is unprotected.
VERIFIED:	(blank)	Y*	Y or N	May be used to indicate that data in Data Set has been verified.
CREATION:	(blank)	Y*	Numeric	The YYMMDD prompt designates the order of a 6-numeral date entry. EXAMPLE: 780515 = 78 May 15
EXP:	(blank)	Y*	Numeric	Expiration date of Data Set; may be entered in form parallel to CREATION: field.
RECORD SIZE:	080	Y	001 - 128	Entry required to specify the logical record size of records in the Data Set.

*These fields on the Data Set Labels Display enable creating data set labels that meet requirements of Basic Data Exchange. For Series 21, these fields may or may not be interrogated.

DISK UTILITY PROGRAM

INTRODUCTION

The MDS-supplied Disk Utility program (DISKU) provides a number of functions that enable control of space on disk by Series 21 systems. The functions include:

- Formatting the disk to create a new catalog and set up initial Free Space descriptors. This is required after Hardware Initialization of a new disk, or to "scratch" a previously used disk. (Refer to *MDS Quick Reference card, How to use DISK/INIT, M-3929*, for Hardware Initialization procedures.)
- Volume labeling, label modification.
- Data Set labeling, including allocation, setting EOD and record size.
- Modification of Data Set labels to change name, allocation or EOD, or to delete selected data set.

DISKU may also be used to peruse the catalog of Data Set Names resident on disk.

Operating procedures for DISKU in this section are organized as follows:

Title	Page
INTRODUCTION	1
DISK SOFTWARE FORMATTING	3
VOLUME LABELING, LABEL MODIFICATION	4
NEW DATA SET LABEL CREATION	5
DATA SET LABEL MODIFICATION	6
Figure XI-1 Description of Fields on Volume Contents Catalog Display	9

BEFORE YOU BEGIN:

- **Controller Console power must be On.**
- **Operator Station power must be On.**
- **MDS Disk Utilities program (DISKU) must be loaded from your Operator Station. If not, see PROGRAM LOAD section of this book.**

CAUTION

If the disk drive is Diablo 2172, do not change disk pack at any point during operation of DISKU.

1. When DISKU is loaded, the following display is presented:

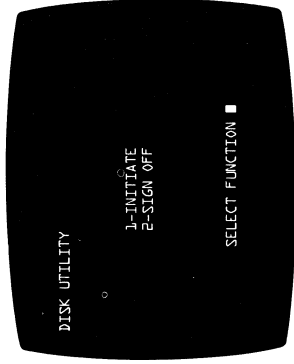

- a. Key '1' to proceed with use of DISKU. Go to Step 2.
OR
 - b. Key '2' to SIGN OFF and return to the System Select "menu" Display.
2. The following display is presented:

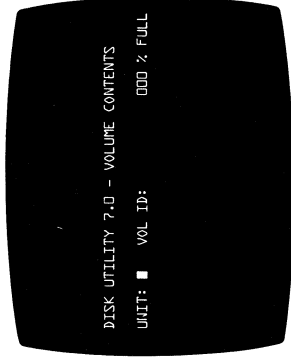

The cursor is positioned in the UNIT: field.

The following options are available:

Press	Effect
SEL MODE	Halts program; system returns to the initial display, enabling SIGN OFF.
D/S OFF	Message 'FREESPACE: 000000' appears, and program increments number as it counts the free space sectors available and calculates the percentage of space used. When completed, the percentage of space used is presented in the 000% FULL field.

CODE/HOME
Readies system to start the Software Formatting process. (See Step 3, following.)

'0' or '1'
then
ENTER
Keying '0' in the UNIT: field directs the system to locate the disk unit number; keying '1' specifies the unit number. In either case, the system fills the VOL ID: field with the 6-character Volume Name (if any exists). Then, pressing **ENTER** causes the program to display the

catalog of Data Set names by number beginning with Data Set number 00001 and the cursor is positioned at the DATA SET NAME: field.

Disk Software Formatting

3. If CODE/HOME has been pressed with the cursor in the UNIT: field of the Volume Contents display, the following warning message appears:

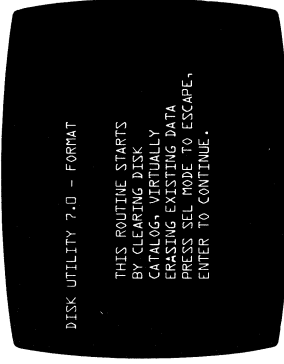

Per the instructions on the display:

- Press **SEL MODE** to escape from the Software Formatting routine. This discontinues the DISKU program, and the Program Select "menu" Display is presented.

- Press ENTER to start the Software Formatting process. The following activity monitor is presented:

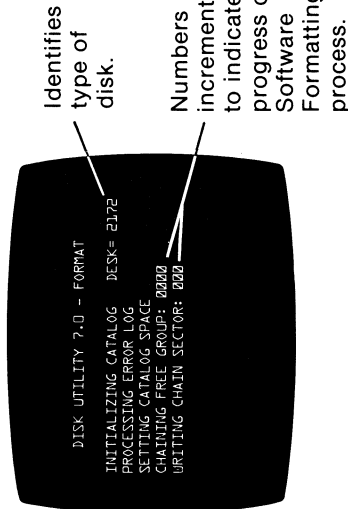

When the process is completed, the program returns to the Volume Contents display and the cursor is positioned in the UNIT: field (see Step 2).

4. If '0' or '1' have been keyed and ENTER is pressed in Step 2, the Volume Contents Catalog display appears with fields filled as in the example in Figure XI-1, Description of Fields on Volume Contents Catalog Display.

The cursor is positioned in the DATA SET NAME: field.

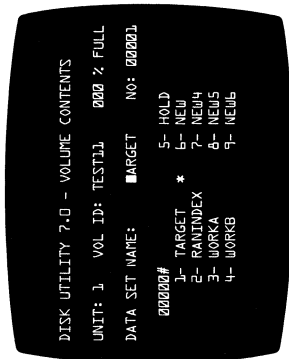

5. The following utility functions may be performed:
 - Change (or enter) Volume Name
 - a. Press Field Backspace key (\leftarrow) to position cursor in VOL ID: field.
 - b. Key new 6-character Volume Name.
 - c. Press ENTER.
 - "Scratch" (prepare for reuse) disk
 - a. Press Field Backspace key (\leftarrow) twice to position cursor in UNIT: field.
 - b. Press CODE/HOME.
 - c. See Step 3, preceding, for procedure.

● Peruse catalog of existing Data Set names.

a. Press SCAN key to advance one-by-one through Data Set names in Catalog.

OR

b. Press CODE/SCAN keys together to back up one-by-one through Data Set names.

OR

c. Press PROG ADV key to advance to next group of 10 Data Set names (if any) in Catalog.

OR

d. Press CODE/PROG ADV keys together to back up to previous group of 10 Data Set names (if any) in Catalog.

● Locate Data Set by Name

a. Key desired Data Set name.

NOTE:

Eight-character name must be keyed exactly as it appears in Catalog, including spaces if any, in order for system to locate Data Set.

b. System locates Data Set, provides its number in NO: field; adjacent Data Set names existing in Catalog will appear in the group of 10 Data Sets listed on the display.

● Locate Data Set by Number

a. Press Field Forward key (\rightarrow) to position cursor in NO: field.

b. Key desired Data Set number.

EXAMPLE: Desired Data Set number is 00011. Key '1', then press EXIT key in lieu of keying the leading zeros.

c. System will search catalog for Data Set number and provide its name in DATA SET NAME: field, and display the group of 10 Data Sets which surround it.

● Create a new Data Set Label

a. Press CODE/ENTER.

b. The system will locate the next available position in the Volume Catalog, and present the Data Set Label (New) display. Go to Step 6.

● Change (update) existing Data Set Label

- a. When the desired Data Set is shown by name in the DATA SET NAME: field and by number in the NO: field, press ENTER.
- b. The system presents the Data Set Label display in the update mode. Go to Step 7.

● Display % FULL value

- a. Press D/S OFF key.
- b. The program calculates the amount of space used, and presents a value in the % FULL field.

6. When the Volume Contents display is present and CODE/ENTER is pressed, the Data Set Label (New) display is presented:

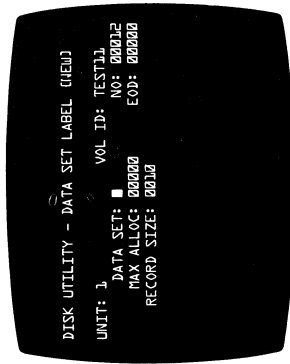

The program provides the Data Set number in the NO: field. The cursor is positioned at the first character in the DATA SET: field.

- a. Key the combination of 1-8 characters (alphabetic or numeric) that are the new Data Set name.

NOTE:

Names may not be duplicated; program checks for duplication before writing Catalog record.

- b. Key the number in the MAX ALLOC: field (range is 00001 to 32768).

NOTE:

The system dynamically allocates space to data sets as it is needed during operation. If any number (from 00001 to 32767) is specified in the MAX ALLOC: field, the system stops allocating space when that physical sector is reached.

- c. Key number in the EOD: field (range is 00000 to 32768).

NOTE:

Setting EOD at the appropriate number of records needed is a means of pre-allocating space to a data set. Then, after pressing ENTER, reset EOD to 00000 if data collection will begin at record 00000.

EOD may not exceed the number keyed (if any) in the MAX ALLOC: field.

- d. Key number in the RECORD SIZE: field (range is 0010 to 4096 bytes).

NOTE:

To be compatible with diskette, set RECORD SIZE to 128 or less. Default value of field is 0010.

- e. Press ENTER. The program writes the new catalog entry, allocates space for the new data set, and proceeds to update mode, thus enabling revision or correction of keyed data.

- f. The following Function Keys may be used at any time while the Data Set Label (New) display is present.

Key(s)

SEL MODE

Effect

Returns to Volume Contents Display. (Pressing CODE/SEL MODE has same effect.)

SCAN

Advances to next Data Set label. Program enters update mode for an old data set, new allocation mode for a deleted data set, or wraps back around to Data Set 1 if end of catalog has been reached.

CODE + SCAN

Same as above, but backing up to previous data set label.

CODE + RESET

If pressed prior to pressing ENTER, restores original values (if any).

- 7. When Volume Contents Display is present and ENTER is pressed, the Data Set Label Display is presented with the details of the dataset specified in the DATA SET NAME: field filled in, and the program enters update mode. The cursor is positioned in the DATA SET: field.

NOTE:

If Data Set selected is deleted, program presents Data Set Label (New) Display. Use procedures given in Step 6, foregoing.

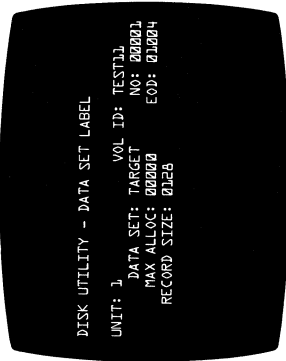

NOTE:

If number in ALLOC: field is reduced, such as from 00455 to 00454, sectors beyond the EOD are released to free space.

- c. The following may also be performed:

Key(s)

SEL MODE

Effect

Returns to Volume Contents Display. (Pressing CODE/SEL MODE has same effect.)

CODE +

HOME

Marks Data Set as deleted and returns all allocated space to free space.

CODE +

ENTER

Program presents Data Set Label (New) Display, enabling creation of a new Data Set.

- a. If name and number of desired Data Set are not displayed, use SCAN key to search forward, or CODE/SCAN keys to search backward, for correct Data Set.
- b. If name and number of Data Set to be updated are present in DATA SET: and NO: field, perform desired modifications to DATA SET:; MAX ALLOC:; EOD:; or RECORD SIZE: fields.

**Figure XI-1 Description of Fields
On Volume Catalog Display**

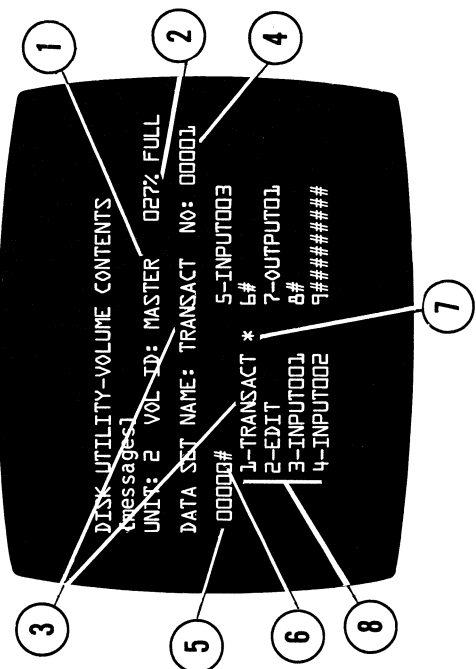

- 1** MASTER = Volume Name
- 2** 027% FULL = Percentage of total space presently used (allocated). Numbers other than 000 present only if D/S OFF has been pressed as described in Step 2.
- 3** TRANSPORT = Name of Data Set No. 00001; appears in DATA SET NAME; field indicating system is presently positioned to access this data set.
- 4** 00001 = Number of Data Set named TRANSPORT; appears in NO; field indicating system is presently positioned to access this data set.
- 5** 00000 = Beginning of Data Set Numbers in Volume Contents Catalog; the leading zeros are assumed for the numbers 1-9 which follow in sequence on the catalog display. (See procedures following to peruse catalog beyond initial group of 10 data sets.)

- ⑥ # = Symbol indicates deleted data set. Since numbering of Data Sets begins with 00001, No. 00000 is always marked deleted and may not be accessed by number. Data Sets (0000)6 and (0000)8 in this example are also marked as deleted, indicating these data sets were deleted following allocation of space.
- ⑦ * = Flags the Data Set Number and Name in the Catalog Display that is shown in the DATA SET NAME: and NO: fields.
- ⑧ EDIT, INPUT001, etc. = Names of other Data Set Names which may be accessed. See Step 5 for procedures.
- ⑨ ##### = End of current Catalog entries for Volume.

PRINTER UTILITIES PROGRAM

INTRODUCTION

The MDS-supplied Printer Utilities Program (PRINTERU) provides functions to modify the contents of a parameters table in the Series 21 Control Program for:

- Vertical forms control
- Horizontal forms control
- VFU control

NOTE:

Specific modifications permitted are dependent on the capabilities of the MDS printer installed. (See PERIPHERALS section of this publication for additional information.)

In addition, PRINTERU allows storage of the modified parameters table on a diskette data set for reuse and/or updating for subsequent use.

PRINTERU may also be used to read previously stored parameters.

The procedures in this section are organized as follows:

Title	Page
INTRODUCTION	1
INITIAL DISPLAY	2
Default Parameters	3
MODIFICATION OF PARAMETERS	4
STORAGE OF MODIFIED PARAMETERS	6
Table XII-1, Valid Entries for Parameters Modification	8

The cursor is positioned at the first character of the VERTICAL LINES/PAGE: field.

3. The following options are available:

- Display DEFAULT PARAMETERS (shown below) by holding CODE key down while pressing RESET key.

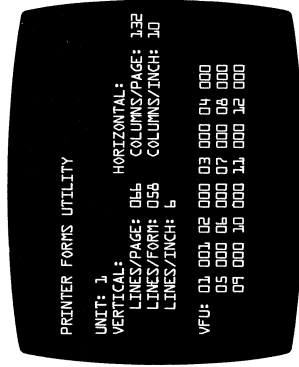

Default Parameters

- Proceed with MODIFICATION OF PARAMETERS, using procedures that follow.
- Press SEL MODE to return to the initial display. Key '2' to SIGN OFF. The system returns the System Select "menu" Display.

MODIFICATION OF PARAMETERS

The initial PRINTERU display, with or without Default Parameters filled in, must be present.

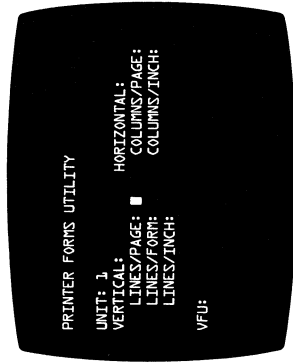

NOTE:

See Table XII-1, Valid Entries for Parameters Modification, found at the back of this section.

3. The following control keys may be used during keying:

Key	Effect
EXIT	Zero fills field from left.
(→)	Advances to next field without modifying content.
(←)	Backs up to previous field without modifying content.
(←)	Backs up one character.
SEL MODE	Returns to initial display. Key '2' to discontinue PRINTERU functions and return System Select "menu" Display.
PROG ADV	Enables skipping remaining fields if modification is not required.

2. Key numerals desired in the fields requiring modification. The sequence of entry offered by the program is as follows:

- a. LINES/PAGE
- b. COLUMNS/PAGE
- c. LINES/FORM
- d. COLUMNS/INCH
- e. LINES/INCH
- f. VFU Table fields

4. When entry is complete, press ENTER to cause modified parameters to be placed in Series 21 Control Program table for use during application.
The message 'FUNCTION COMPLETE' is presented. Press RESET to acknowledge message.

NOTE:

If desired, modified parameters can be stored on a diskette data set. See STORAGE OF MODIFIED PARAMETERS subsection, following.

5. The display remains as keyed, with the cursor returned to the LINES/PAGE field, enabling re-keying if needed. (If values are re-keyed, press ENTER again.)
If no corrections are needed, press SEL MODE to discontinue PRINTERU and return to the System Select Menu Display.

STORAGE OF MODIFIED PARAMETERS

NOTE:

Data set to be used for storage of modified parameters must be named and allocated prior to specification in this procedure.

1. After pressing ENTER as the final step during MODIFICATION OF PARAMETERS, the Printer Forms Utility Display remains with fields as entered.

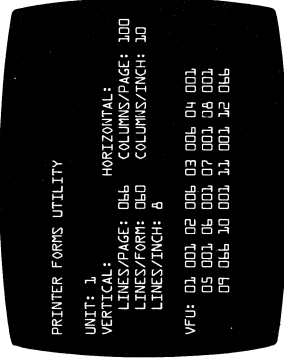

2. Hold CODE key down and press ENTER key. The following display is presented:

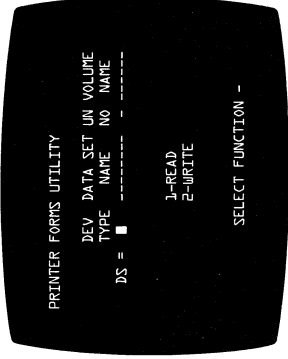

Data Set Select Display

The cursor is positioned in the DEV TYPE field. F (for diskette) is the default value.

NOTE:

If the data set to be read/written is resident on disk rather than on diskette, key 'D' for disk. The cursor advances to the DATA SET NAME position.

3. Key the 8-character Data Set Name of the data set to be read or written. The cursor advances to the UN NO field.
4. Key unit number (1-4) of the diskette drive in which diskette is resident. If disk, use SKIP key or Field Forward key (\rightarrow) to advance through the field. The cursor advances to the VOLUME NAME field.
5. Entry of VOLUME NAME is optional. Use SKIP or (\rightarrow) to advance cursor to the SELECT FUNCTION field at the bottom of the display.
6. Select READ or WRITE function as follows:
 - a. Key '1' to select READ if specified data set contains parameters previously stored. The program locates the specified data sets and presents the stored parameters.

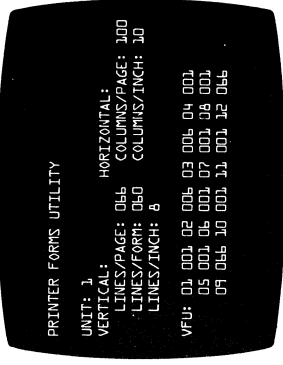

The cursor is positioned at the LINES/PAGE: field to enable changes to stored parameters, if desired.

- If so, follow procedures for MODIFICATION OF PARAMETERS.
- If not, press ENTER. Then SEL MODE may be pressed to return the initial display. Key '2' to SIGN OFF. The System Select "menu" Display is returned.

- b. Key '2' to select WRITE. The program locates the specified data set and writes the modified parameters to the data set.

When finished, the message 'FUNCTION COMPLETE' is presented. Acknowledge message by pressing RESET key. The program returns the Printer Forms Utility Display with the parameters as written. The cursor is positioned in the LINES/PAGE field to enable further modification, if desired.

Press SEL MODE to return to the initial display. Key '2' to discontinue use of PRINTERU. The System Select "menu" Display is returned.

Table XI-1 Valid Entries For Parameters Modification

FIELD NAME	VALID ENTRIES (RANGE)	DEFAULT VALUE	FIELD NAME	VALID ENTRIES (RANGE)	DEFAULT VALUE
VERTICAL: LINES/PAGE:	001 — 132	066	VFU (Vertical Format Unit) Channel Number 01	001 — 132	001
VERTICAL: LINES/FORM:	001 — 132	062	02	001 — 132	000
VERTICAL: LINES/INCH:	6 or 8	6	03	001 — 132	000
HORIZONTAL: COLUMNS/PAGE:	001 — 132	132	04	001 — 132	000
HORIZONTAL: COLUMNS/INCH:	10 or 12	10	05	001 — 132	000
			06	001 — 132	000
			07	001 — 132	000
			08	001 — 132	000
			09	001 — 132	000
			10	001 — 132	000
			11	001 — 132	000
			12	001 — 132	000

PERIPHERALS

OPTIONAL DEVICES AND FEATURES

This section contains operating instructions for the optional peripheral devices and features that can be included in a Series 21 system configuration.

Device set-up instructions provided include:

PRINTERS — power-up, loading forms, changing ribbons, printing adjustments

TAPE DRIVES — power-up, loading/unloading tape reels

DATA-RECORDER INTERFACE — pre-operation procedures, operation

DISK DRIVE — loading/unloading disk, indicators

Information is also provided on the use of the Compatible Channel feature.

This section may be used universally, for all programs. Note, however, that not all devices are supported by all programs.

Device or Feature	Page
2141 Printer	2
2142-1 and 2142-2 Printer	7
2145 Printer	13
2481 and 2482 Magnetic Tape Drive	27
2181 and 2182 Magnetic Tape Drive	31
Data-Recorders (Series 21 Interface)	
1103 Model	40
6403 Model	42
7505 Model	45
2172 Disk Drive	48
Compatible Channel	50

2141 PRINTER

The Model 2141 is a 45 character-per-second printer. This printer can accommodate a 132-character print line, and uses a 96-character set. Characters are contained on a print wheel that is easily removed for cleaning or replacement.

PRINTER SET-UP AND OPERATION (See Figure A).

Power-Up

1. Insure that printer is plugged in, and the printer circuit breaker is on (up position is ON).
2. Press the printer POWER switch; the switch illuminates when power is ON.
3. Press the ON LINE switch; the switch illuminates when printer is ON LINE.

Loading Forms (Standard Friction Platen)

1. Insert paper down behind platen.
2. Manually bring paper to front of platen by turning the platen knob. (The right hand platen knob may be pushed in to allow the platen to "free-wheel" for fine paper positioning.

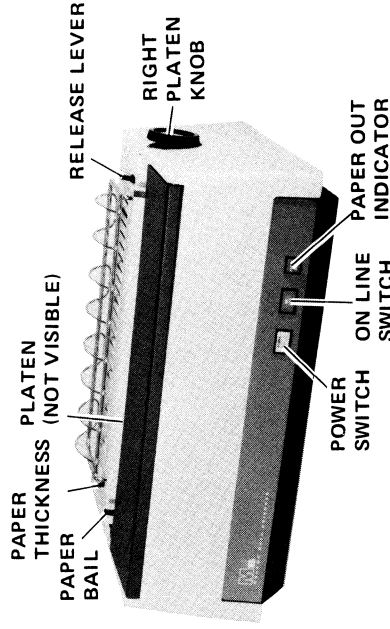

REAR VIEW (PRINTER STAND)

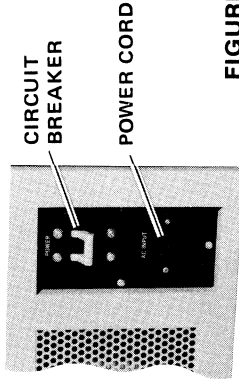

FIGURE A

NOTE:

The paper bail may be pulled forward to aid in directing paper over the top of the platen. For further paper alignment, the release level may be pulled forward to remove tension from the paper.

3. Return paper bail and release lever to operating position.
4. If necessary, adjust paper thickness lever for the paper or forms being used.

Using the Optional Form Tractors (See Figure B)

To Install the Form Tractors:

- a. Push in the two Release Buttons and place the tractor mechanism over the platen.
- b. Position the tractor mechanism so the bottom latches on the tractor mechanism line up with the slots on the platen.
- c. Secure the tractor mechanism in place by pushing it down onto the platen.

Loading Forms (Optional Form Tractors)

To Load Forms:

- a. Lift up on the top paper cage.
- b. Insert forms down and behind platen.
- c. Pull forms up and past the tractors.

- d. Open the pressure plates on the tractors.
- e. Place the feed holes on the feed pins of the tractors (insure that the forms are parallel with the platen).

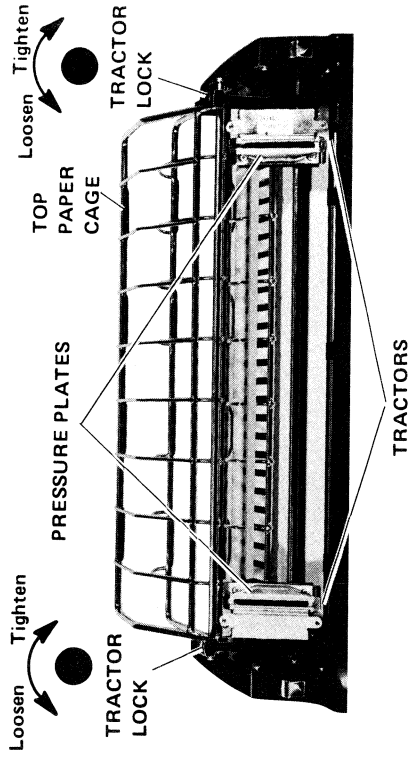

FIGURE B

NOTE:

If it is required to change the position of the tractors to accommodate the form width, loosen the left tractor lock, and move the left tractor as required. Snugly hand-tighten the left tractor lock, then close the left tractor lock. Repeat the procedure for the right tractor.

- f. Close pressure plates.
- g. Feed the forms under the top paper cage, removing any slack in the forms, then close the top paper cage.

Operation

1. Load forms (as described above).
2. Power-up the printer.
3. Press the ON LINE switch; the ON LINE switch illuminates green when on.
4. The printer is ready for operation under control of the program that is loaded in the Series 21 Controller Console.

To Manually Stop or Suspend Printing

1. Press the ON LINE switch while illuminated. Printing is suspended. To resume printing, press the ON LINE switch again.

To Replace the Printer Ribbon (See Figure C).**NOTE:**

Printer Power must be off.

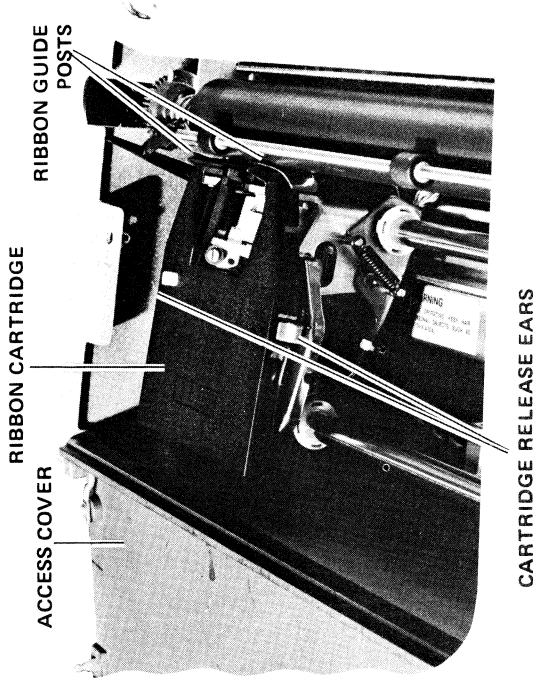
**FIGURE C**

1. Open access cover on the top of the printer.
2. Locate the cartridge release "ears", and move them in the direction indicated in the figure to release the ribbon cartridge. Note the manner in which the front of the ribbon is threaded past the ribbon guide posts.
3. Remove the ribbon cartridge and replace with a new ribbon cartridge. Push down slightly until the cartridge snaps in place. Insure that the ribbon is correctly threaded past the ribbon guide posts.
4. Close the access cover on the printer.

To Change the Print Wheel (See Figure D)

NOTE:

Printer Power must be off.

1. Remove the ribbon cartridge as instructed above.
2. Tilt the carriage back.
3. Grasp the rubber hub on the print wheel and pull it straight off the carriage.
4. To install a print wheel, align the slot in the print wheel with the protruding tab on the carriage shaft hub, and steadily push the print wheel onto the shaft until fully seated.

5. Tilt the carriage back into operating position.
6. Replace the ribbon cartridge.
7. Close the access cover.

To Adjust Printing Intensity (See Figure D)

NOTE:

Printer Power must be off.

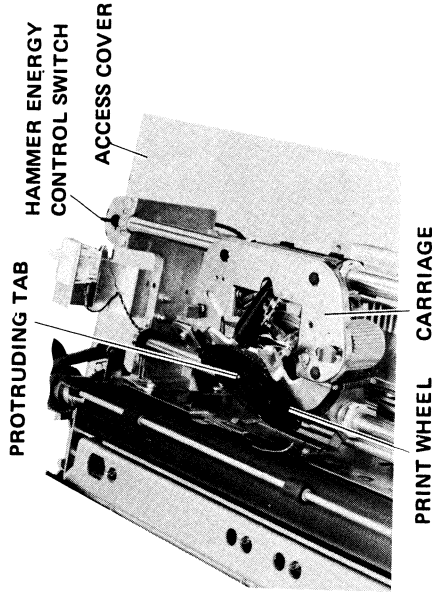

FIGURE D

The HAMMER ENERGY CONTROL SWITCH may be adjusted as follows to accommodate print wheel font variations, or multiple part forms:

- H — HIGH, used for printing multiple forms.
- M — MEDIUM, used for normal printing operations.
- L — LOW, used for light printing (to extend the life of delicate light type fonts).

Printer PAPER OUT Indicator (See Figure A)

When the printer paper or forms supply is depleted, the red PAPER OUT indicator is lit and printing is suspended.

To suspend printing, press the ON LINE switch (to out position). This action places the printer off-line, and the ON LINE switch/indicator goes out. Perform the Loading Forms procedure, then press ON LINE to resume printing.

2142-1 AND 2142-2 LINE PRINTER

INTRODUCTION

The Model 2142-1 and 2142-2 Line Printers can accommodate up to 132 character print lines. Characters are contained on print belts that include two 96 character fonts, or three 64 character fonts. Print ribbons are in easily replaceable cartridges; paper (forms) motion is achieved by sprocket (tractor) feed. Printer speeds are dependent upon font, and are listed below.

Model No.'s	Character Fonts	Lines Per Minute		Printing Speed	
		80 Column Line	132 Column Line	80 Column Line	132 Column Line
		Min.	Max.*	Min.	Max.*
2142-1	96	150	185	90	130
2142-2	96	240	240	230	240
2142-1	64	150	185	90	130
2142-2	64	340	340	230	340

*Maximum values are based on 64 characters per line for 80 column line lengths, and 96 for 132 column line lengths. Minimum values are based on 80 and 132 characters per line respectively.

Printer Set-Up and Operation

Power Up (See Figure A)

Printers, continued

1. Insure the printer is plugged in.
2. Position the POWER ON switch to ON.

Switches and Indicators

1. Figure B indicates the functions of all switches and indicators.

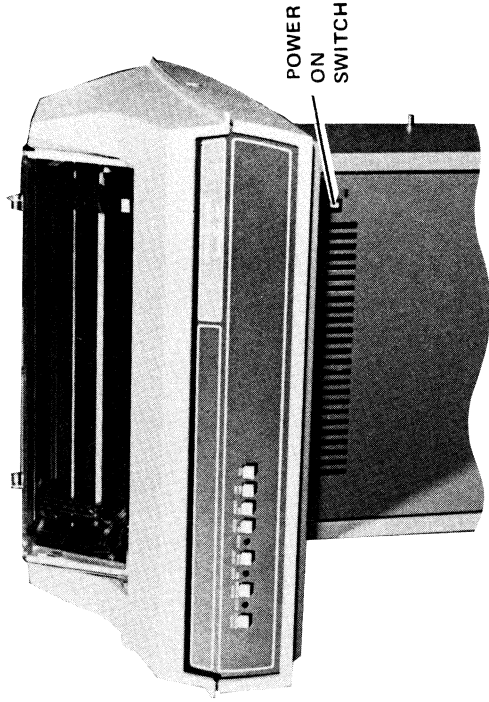

FIGURE A

Indicators

- ① **SELECT**
Lights when Printer is selected to go on line either by data source or SELECT pushbutton.
- ② **PAPER OUT**
Lights to indicate activation of low paper sensor or PLATEN RELEASE switch in LOAD position.
- ③ **ALARM**
Lights, and print motor turns off when following alarm conditions occur:
 - VT or FF commanded with no tape in VFU mechanism.
 - Paper Out from Paper Out Sensor. Print Belt Underspeed.
 - Print Belt Underspeed.
 - Printer Fault.

The ALARM will not go out until the alarm condition is corrected and the print motor is turned on (or the AC power is cycled).

Pushbuttons

- ④ **SELECT**
Alternate pressing selects the Printer to receive or not receive data.
- ⑤ **FORMS OVERRIDE**
Deactivates low paper sensor to allow completion of printing on form in process.
- ⑥ **TOP OF FORM**
Advances paper to next hole punched in channel 1 of VFU tape loop. If VFU loop is missing, paper advances just 1 line.
- ⑦ **MOTOR ON**
When pressed, turns on motor (if power is on) for printing or test.

- ⑧ **MOTOR OFF**
When pressed, turns off motor if it is running.
- ⑨ **LINE FEED**
Causes paper to advance one line each time it is momentarily pressed.
- ⑩ **TEST**
When pressed, a test pattern is generated by test circuits in the printer to test the basic print functions. All printing characters, in sequential counting order of the ASCII Code, are printed during the test.

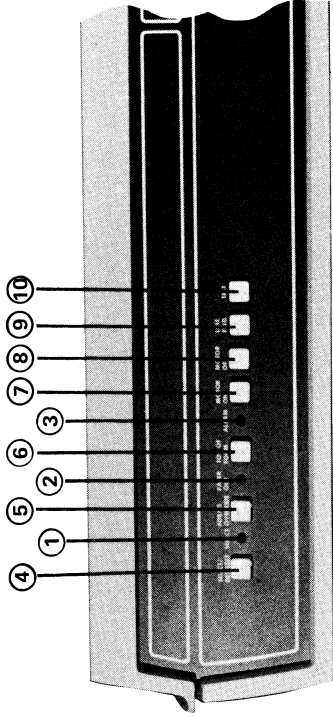

FIGURE B

Forms (Paper) Loading (See Figure C)

1. Press the MOTOR OFF switch, then move the plastic paper shield forward.
2. Push the RUN/LOAD lever in and down.
3. Open the pressure plates, then remove existing forms, if any.
4. Push down on the tractor release levers, then approximately position the tractors for width of forms to be used.
5. Use procedure a. or b. for paper loading:
 - a. Rear Loading: Insert paper through opening at rear of printer, until paper is just past tractors, and against the left paper guide to accommodate the Low Paper and Out of Paper sensors.
 - b. Front Loading: Insert paper up through opening in bottom/front of printer until paper is just past tractors and against left paper guide to accommodate the Low Paper and Out of Paper sensors.

NOTE:

- Make sure the front Low Paper sensor jack is plugged in under the left/front side of the printer.
6. Align the paper, engage its holes with the tractor pins, then close the pressure plates.

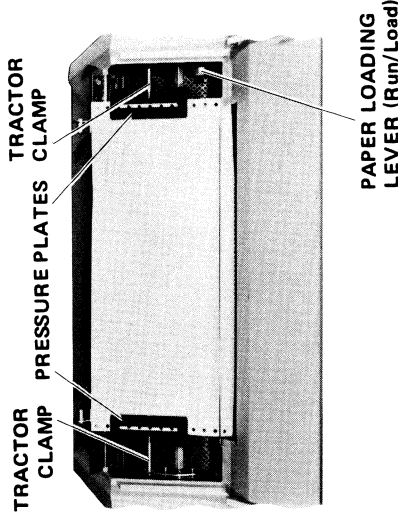
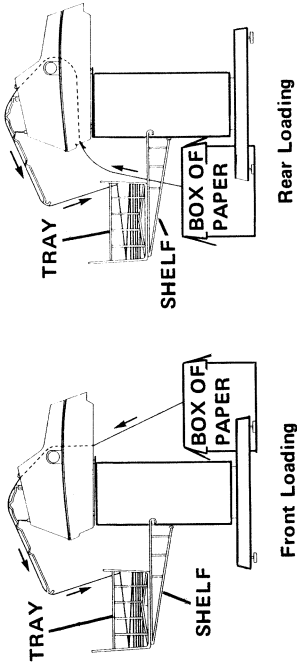

FIGURE C

7. If necessary, reposition the tractors to remove wrinkles from the paper, then push the locking levers up, to lock the tractors in place.
8. Push the RUN/LOAD lever up, then lower the plastic shield.
9. Press the MOTOR ON switch, then press the LINE FEED switch a few times. Paper should feed one line for each depression of the LINE FEED switch.
10. Press the TOP OF FORM switch. Paper should move to top of next page if the VFU loop is installed. If it is not installed, paper should advance one line.
11. Push the platen knob inward, then rotate it counterclockwise until the first print position is reached on the next page.
12. Make sure outgoing paper does not contact incoming paper.

NOTE:

Step 9 may have to be repeated if top of form position was not accurate.

Ribbon Cartridge Installation (See Figure D)

CAUTION:

DO NOT OPERATE THE PRINTER UNLESS THE RIBBON CARTRIDGE IS INSTALLED. FAILURE TO OBSERVE THIS CAUTION CAN RESULT IN SEVERE PRINT FINGER WEAR AND/OR DAMAGE.

Ribbon Must Be Between Platen And Fingers.

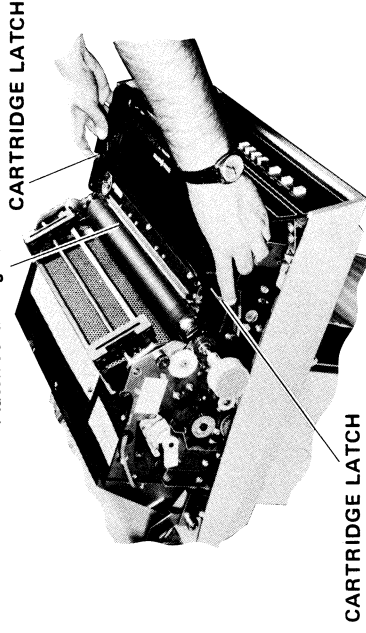

FIGURE D

1. Press the MOTOR OFF switch, then raise the top cover.
2. Insure the RUN/LOAD lever is set to RUN.
3. Using both hands, release the latches on each side of the cartridge, then lift to free the cartridge.
4. Before installing the replacement cartridge, remove its ribbon stop (there for shipping purposes), then rotate the drive knob (on left) counterclockwise to remove ribbon slack.
5. While holding the cartridge latches back, position the new cartridge over its locating pins, then while observing that exposed ribbon is between print fingers and platen, press downward until locking latches snap into place.
6. Insure latches are fully in position.
7. Lower the top cover, press the MOTOR ON switch, then observe that ribbon and fingers track properly.

VFU Tape Installation (See Figure E)

NOTES:

- a. Tape must consist of 1" wide (2,54 cm), eight channel, black paper or opaque mylar.

- b. Minimum length must be no less than 6.6" for 11" paper. Maximum length is dictated by the confines of the tape guides.
 - c. A hole in channel one must be repeated as often as required for the length of tape used in respect to forms (paper) length.
1. Raise the printer's top cover.
 2. Lift the VFU tape hold-down cover.
 3. Slide the tape (channel 1 first) into the tape reader, then position the sprocket holes over sprocket teeth.
 4. Lower the hold-down cover, then gently move the tape to insure it is engaged by the teeth.
 5. Close the top cover.
 6. Press the TOP OF FORM switch. Paper (installed) should advance until the first form feed hole is read.
 7. If first print line of paper is not in print position, press platen knob inward, then rotate it until first line of print on next form is correctly in position.

Operation

1. Position POWER ON switch to ON.
2. Insure required VFU loop is installed.
3. Insure ribbon cartridge is installed.
4. Install paper.
5. Press MOTOR ON switch.
6. Insure paper is at Top of Form.
7. Press SELECT switch. (Select indicator lit — indicates printer in On-Line to the Series 21 Controller Console).
8. To manually stop printing — press the SELECT switch. Select indicator goes out (Off-Line).
9. In the event printing stops due to an alarm condition, the alarm condition must be corrected, the MOTOR ON switch is pressed, then the SELECT switch is pressed.

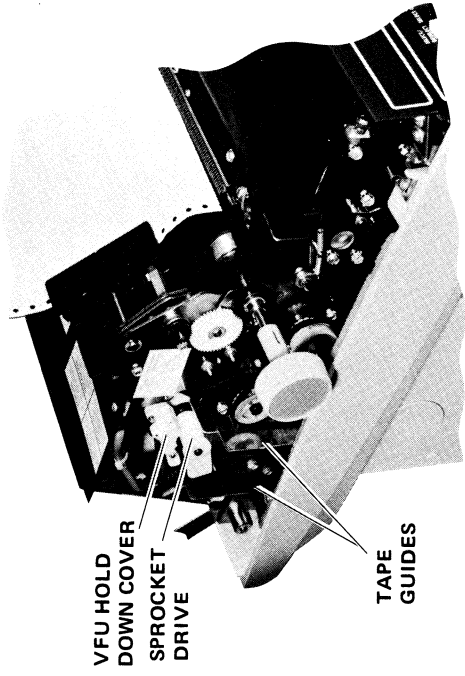

FIGURE E

2145 PRINTER

The Model 2145 is a 600 lines-per-minute printer. This printer can accommodate a 132-character print line and uses a 64-character set. Characters are contained on a character drum.

3. Lift printer cover (see Figure C).
4. Pull drum gate latch and swing drum gate fully open (see Figure A).

PRINTER SET-UP AND OPERATION

On-Line Start-Up Procedure

1. Insure that PRINT INHIBIT switch is set to OFF position (see Figure A).
2. Set MAIN POWER circuit breaker to ON (See Figure A). After approximately 4 seconds, verify that POWER ON and READY indicators at operator control panel illuminate (See Figure B).
3. Press and release ON/OFF LINE switch to place printer in on-line mode (See Figure B).
Verify that ON/OFF LINE indicator illuminates.

Loading Forms

1. Set MAIN POWER circuit breaker to ON (see Figure A).
2. Press and release TOP OF FORM switch (see Figure B).
Tractors will automatically advance to top-of-form position (see Figure A).

CAUTION

WAIT FOR CHARACTER DRUM TO STOP ROTATING BEFORE PROCEEDING TO STEP 5.

5. Open the spring-loaded pressure-plates on the tractors.
6. Place paper in the tractors and close pressure-plates (align paper perforations with tractor sprockets).

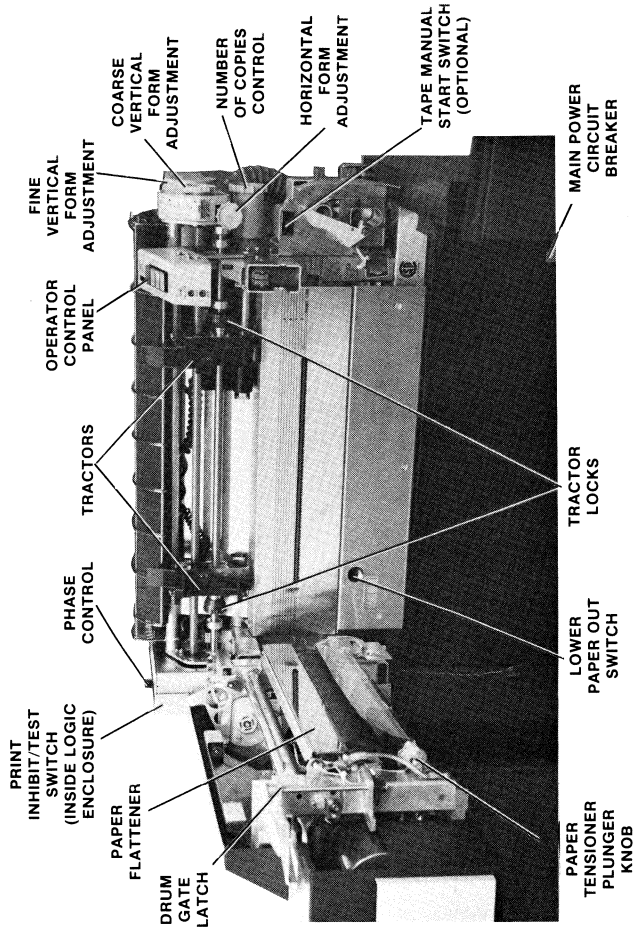

FIGURE A

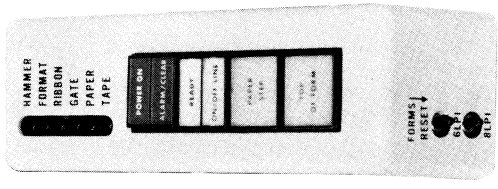
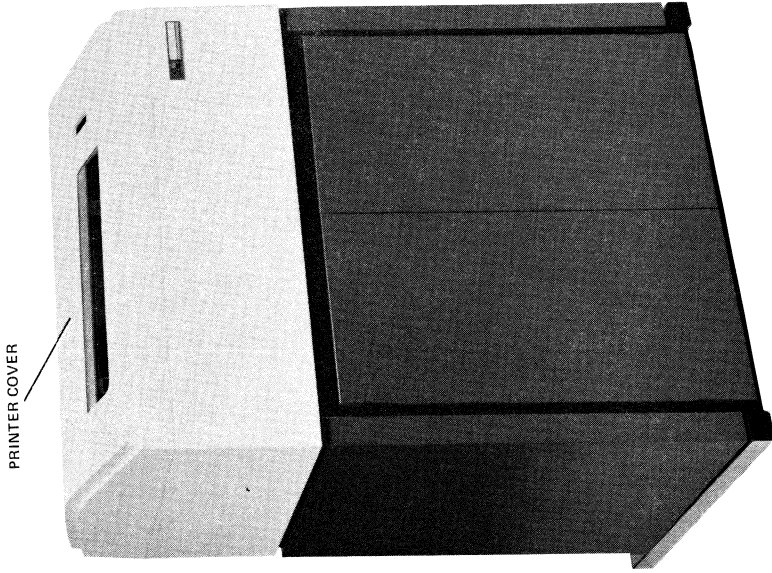

FIGURE B



7. Loosen both tractor locks (see Figure A).
Move both tractors laterally to adjust for correct paper width. Tighten tractor locks.
8. Depress FORMS RESET switch at operator control panel, if necessary, to align the paper perforation near the desired top-of-form print position (see Figure D).
Note that holding the FORMS RESET switch depressed while rotating the tractor shaft using the COARSE VERTICAL FORM ADJUSTMENT control (see Figure A) allows the top-of-form adjustment to be made.
Release FORMS RESET switch after aligning top-of-form.
9. Horizontally position paper by adjusting HORIZONTAL FORM ADJUSTMENT control (see Figure A).
Left margin index marks are shown in Figure D.
10. Verify NUMBER OF COPIES control is set correctly for the form being used (see Figure A).
11. Close the latch drum gate and close printer cover.

FIGURE C

Printers, continued

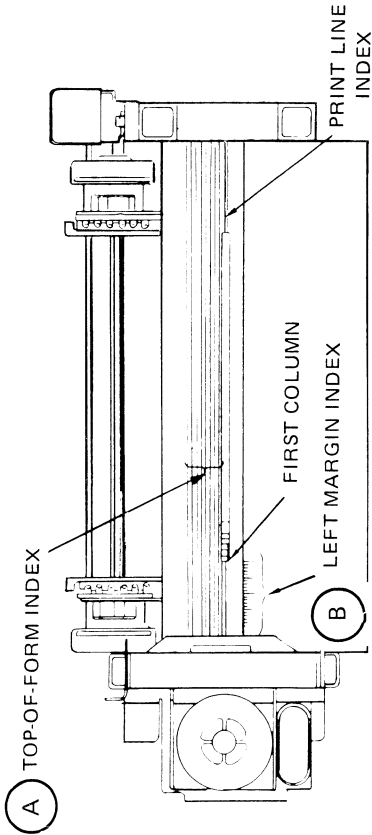

EXAMPLE

Top-of-Form/Paper Alignment Guidelines

- A The top-of-form index indicates where the paper perforation should be positioned to allow the first line of print to appear on any one of nine lines after the paper perforation
- B The left margin index indicates where the edge of the paper should be positioned for left hand margins of up to two inches.
- C The example shows the paper properly installed for the first line of print occurring on the third line of the form (a two-line top-of-form spacing) with a one-inch left margin.

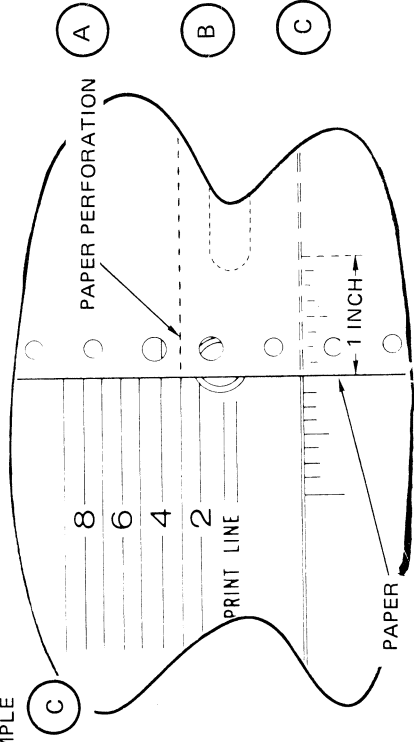

FIGURE D

Operation

1. Insure printer is plugged in.
2. Insure that PRINT INHIBIT switch is set to OFF.
3. Power-up the printer.
4. Insure that forms are loaded.
5. Depress and release ON/OFF switch.
6. The printer is ready for operation under control of a Series 21 application program.
7. Observe printer operation. If necessary, use FINE VERTICAL FORM ADJUSTMENT control (see Figure A) to correct any small vertical mis-alignment in printout.

NOTE:

Printing should begin at Top-Of-Form to avoid loss of one or more lines if paper runs out during operation.

To Manually Stop or Suspend Printing

1. Press and release ON/OFF switch/indicator.
Observe that indicator extinguishes after printing of the current line is completed.
2. To resume printing, press and release ON/OFF LINE switch.

To Remove/Replace Printer Ribbon

Removal:

NOTE:

Use the plastic gloves supplied with the ribbon when installing or replacing ribbon.

1. Lift printer cover (see Figure C).
2. Release drum gate latch and swing gate fully open (see Figure A).

CAUTION

IF POWER APPLIED, WAIT FOR CHARACTER DRUM TO STOP ROTATION.

3. Hold paper tensioner (see Figure E) with one hand, pull paper tensioner plunger knob and remove the paper tensioner.
4. Pull right end of ribbon cores away from drum gate (see Figure E) by: (1) grasping the right end of the top and bottom fixed ribbon holders; and (2) push against floating holder springs.
5. Discard old ribbon cores.

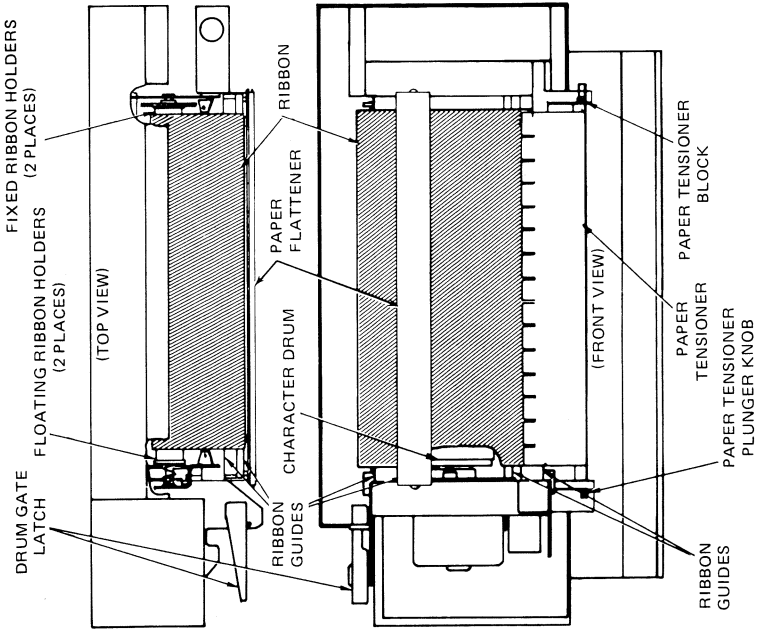

FIGURE E

Replacement

1. Remove the printer ribbon cores.
2. Hold ribbon cores together and remove ribbon from box.
3. Place fully-wound ribbon core over top floating ribbon holder (see Figure E).
Ribbon must unwind from top of ribbon core.
4. Push against floating ribbon holder spring and place opposite ribbon core end over the top fixed ribbon holder.
Ensure holder guide-pin slips into slot on the core end.
5. Unwind second ribbon core and bring down over the character drum and ribbon guide bars.
6. Place core on bottom ribbon holder as in Step 4.
7. Install paper tensioner by inserting the paper tensioner block into position (see Figure E).
Push the paper tensioner against the paper tensioner knob while pulling the knob to allow it to engage.
8. Close the drum gate and lower the printer cover.

TABLE 1. OPERATOR CONTROL PANEL

Control and/or Indicator	Function
POWER ON-ALARM/CLEAR:	a. Illumination indicates all dc voltages are within their tolerances and the initial power up delay (approximately four seconds) has been completed.
POWER ON INDICATOR	b. Off (with MAIN POWER circuit breaker set to ON) indicates that the Voltage Monitor Delay signal (VDEL) is active. During initial power on, VDEL is active for approximately four seconds while the dc levels are stabilizing. When the dc levels have stabilized, VDEL goes inactive and POWER ON indicator illuminates. If VDEL again becomes active, this indicates that the output of the +5 Vdc, +12 Vdc, -4 Vdc, -11.8 Vdc, or +65 Vdc supply has dropped, indicating a power supply fault. If VDEL becomes active during a print cycle, the print cycle in progress will not be completed.
ALARM indicator	a. Illumination indicates a fault condition exists. A fault condition will take the printer off-line. If the specific fault condition has an associated indicator, that indicator will also be lit.
CLEAR switch	b. Illuminates when the character drum is not rotating at its proper speed (drum speed fault).
READY-ON/OFF LINE: READY indicator	c. Illuminates when the Print Inhibit switch is in the On position and the READY indicator is lit. Pressing the CLEAR switch will master-clear (initialize) printer logic.
ON/OFF LINE indicator	Illumination indicates that all interlocks are satisfied, there is no fault condition, and the printer is ready to be placed on-line.
	Illumination indicates that the printer is on-line and controlled by the user system. At initial power up, indicator will be off.

TABLE 1. OPERATOR CONTROL PANEL (Cont'd.)

Control and/or Indicator	Function
ON/OFF LINE switch	Pressing the ON/OFF LINE switch alternately places the printer on-line and off-line. At initial power up, printer will be in the off-line mode.
PAPER STEP switch	Pressing the PAPER STEP switch advances paper to the next line. Switch is disabled when the printer is on-line and during a tape loading operation of the Tape VFU option.
TOP OF FORM switch	Pressing the TOP OF FORM switch advances paper to the top of the next form. Switch is disabled when the printer is on-line and during a tape loading operation of the Tape VFU option.
FORMS RESET switch	Allows manual override of the paper feed servo system so that paper may be repositioned during the time power is on. (Refer to COARSE and FINE VERTICAL FORM ADJUSTMENT controls for the direct application of this switch).
6LPI/8LPI switch	The 6LPI/8LPI switch permits the operator to select either six- or eight-lines per inch vertical spacing.
Fault Indicators:	Illumination indicates the occurrence of a printer fault condition which will cause the printer to go off-line upon completion of the print cycle in progress. These indicators light in conjunction with the ALARM indicator.
HAMMER fault indicator	Illumination indicates that hammer current is flowing when a hammer should not be firing, or that no hammer fired although at least one was addressed. This indicator does not light when the Print Inhibit switch is in the On position, however.

TABLE 1. OPERATOR CONTROL PANEL (Cont'd.)

Control and/or Indicator	Function
FORMAT fault indicator	Illumination indicates that the line strobes generated in the control logic are not comparing with the strobes generated by the line count track (6 or 8) on the position encoder disc. A format fault is cleared by actuating the FORMS RESET switch.
RIBBON fault indicator	Illumination indicates that ribbon direction has failed to reverse at the end of a spool, a ribbon motor is open or shorted, or a ribbon snag has developed.
GATE fault indicator	Illumination indicates that the drum gate is unlatched. Assuming power is on, opening the drum gate will cause the printer logic to be master cleared.
PAPER fault indicator	Illumination indicates that the printer is out of paper, the paper is torn, or paper runaway has occurred. A paper runaway is a failure of the paper feed system to come to a stop within approximately three seconds. A paper fault is cleared when the printer is master cleared.
TAPE fault indicator (optional)	Illumination indicates a parity error has been detected in the VFU memory, or a tape channel command has been issued for which no hole has been punched.

TABLE 2. OPERATOR/MAINTENANCE CONTROLS

Identification	Function
MAIN POWER circuit breaker (located below the print station)	This switch controls application of AC primary power to the printer.
COARSE VERTICAL FORM ADJUSTMENT (located to the right of the operator control panel)	This control permits the operator to vertically position the form in predetermined increments. To make a coarse adjustment, the FORMS RESET switch must be held in the down position to prevent a format error from occurring.
FINE VERTICAL FORM ADJUSTMENT (located to the right of the operator control panel)	This control permits the operator to vertically position the form between the predetermined incremental range of the coarse vertical form adjustment above. This control moves the paper drive phase encoder which positions the line strobe pulse to occur at the desired position on the form. To make a fine adjustment, the FORMS RESET switch must be in the up position.
HORIZONTAL FORM ADJUSTMENT (located to the right of the operator control panel)	This control moves both tractors simultaneously to permit the operator to fine position the form horizontally.
NUMBER OF COPIES control (located below the vertical form adjustments)	This control permits the operator to adjust the spacing between the character drum and the hammer bank (between which the paper moves during printing), and is used to compensate for the thickness of multi-part forms.

TABLE 2. OPERATOR/MAINTENANCE CONTROLS (Cont'd.)

Identification	Function
Tractor locks (located on the printer mechanism)	These controls are loosened to permit the operator to align the tractors with the paper edge-punched holes and permit course horizontal form adjustments.
PHASE (Phasing) control (located atop logic enclosure)	This control allows the operator to adjust the print hammer firing to maintain equal print density at the top and bottom of the character.
Print Inhibit switch (located on the control logic card, inside the logic enclosure).	When set to the On position (toward the connector edge of the control logic card), this switch inhibits the print hammer driver circuits for test purposes. For normal printing, this switch is set to the off position (away from the connector edge of the control logic card).

Operating Problems

Table 3 provides a list of common problems that could be encountered in operating the printer. The Table describes indicator conditions, probable causes, and corrective actions. If the corrective action specified does not correct the problem, or if a problem has indicator conditions not listed, contact MDS customer services. Controls and indicators referred to in Table 3 are shown in Figure B and are described in Table 1.

Table 3. Operating Problems

Indicator Conditions	Probable Cause	Corrective Action
POWER ON indicator does not light	a. MAIN POWER circuit breaker is in OFF position. b. Internal voltage requirements are not satisfied or initial delay circuit is inoperative.	a. Set MAIN POWER circuit breaker to ON. b. Inform service personnel.
READY indicator unlit, ALARM indicator lit	Fault condition exists.	Press and release CLEAR switch. If fault condition remains, lift printer cover and observe fault indicators.
ALARM and READY indicators lit	Print Inhibit switch is set to on.	Set Print Inhibit switch to off.
ON/OFF LINE indicator does not light, or will not go out	Logic format has not initialized.	Press and release CLEAR switch, observe that ribbon is moving, then press and release ON/OFF LINE switch.
TOP OF FORM or PAPER STEP switches do not function	Printer is in on-line mode (ON/OFF LINE indicator lit).	Press and release ON/OFF LINE switch.
PAPER fault indicator lit	Paper is torn or printer is out of paper.	Repair torn paper or install paper; press and release CLEAR switch.

Table 3. Operating Problems

Indicator Conditions	Probable Cause	Corrective Action
RIBBON fault indicator lit	Ribbon is stalled.	Check for foil on ribbon; replace ribbon if necessary. Press and release CLEAR switch.
GATE fault indicator lit	Drum gate unlatched.	Latch drum gate.
FORMAT fault indicator lit	Paper was adjusted vertically without actuation of the FORMS RESET switch.	Actuate FORMS RESET switch.
HAMMER fault indicator lit	Machine malfunction.	Inform service personnel.
Excessive noise when paper fold passes print station	NUMBER OF COPIES control not set correctly.	Set NUMBER OF COPIES control to form thickness (1-to 6-part).
TAPE fault indicator lit	VFU tape load fault or VFU memory parity error.	Reload VFU tape. If fault condition remains, replace VFU tape and reload.

2481 AND 2482 MAGNETIC TAPE DRIVE

The Model 2481 is a 9-channel, NRZI, 800 bpi magnetic tape drive. The Model 2482 is a 9-channel, Phase Encoded, 1600 bpi magnetic tape drive. Each model is capable of reading and writing magnetic tape.

The recording medium for both models is 1/2-inch, computer-compatible magnetic tape.

Loading a Tape Reel

1. Open dust cover.
2. Check write enable ring on supply reel.
To prevent writing, remove ring.
For write operation, insert ring.
3. Mount supply and take-up reels.
4. Thread tape.

Open shield over read/write head, thread tape as illustrated in Figure B. Close shield.

Hold the tape in the take-up reel and turn reel clockwise until four wraps of tape are taken up.

CAUTION

TENSION ARMS MUST BE IN REST POSITION AS ILLUSTRATED IN FIGURE B. BACK OFF TAPE IF NECESSARY.

5. Close dust cover.
6. Press POWER ON switch.



FIGURE A. Tape Drive Control Panel

7. Press RESET.
8. Press LOAD/UNLOAD switch.
Tape will move forward until BOT is sensed. The LOAD POINT indicator will illuminate at this point.
9. Press REMOTE switch. (Insure REMOTE indicator is illuminated when REMOTE switch is pressed).

NOTE:

To obtain local mode press RESET switch, then perform local operations.

Unloading A Tape Reel

1. Press RESET switch, then LOAD/UNLOAD switch.
Tape rewinds to BOT tab, then rewinds at low speed until take-up reel is unloaded.
2. Slide open dist cover.
3. Rewind leader portion of tape by rotating supply reel counterclockwise until all tape is on supply reel.

4. Release supply reel and remove reel of tape.
5. Close dust cover.

Table 1. Tape Drive Switches and Indicators

Switch/Indicator	Function
POWER OFF Switch/Indicator	Removes power from the tape drive and illuminates POWER OFF indicator.
POWER ON Switch/Indicator	Applies power to the tape drive and illuminates POWER ON indicator.
FILE PROTECT Indicator	Illuminated when reel is mounted without write enable ring thus preventing writing on the tape.
LOAD POINT Indicator	Illuminates when BOT is sensed.

Switch/Indicator	Function
REMOTE Switch/Indicator	Manually places tape drive online to the processor. Deactivates tape motion control switches. When in remote status, REMOTE switch/indicator is illuminated.
REWIND Switch	Initiates a high speed rewind to load point.
RESET Switch/Indicator	Performs a tape drive general-clear and establishes local control. Tape motion is stopped when the RESET switch/indicator is pressed.

Table 1. Tape Drive Switches and Indicators (Cont'd.)

Switch/Indicator	Function
LOAD/UNLOAD Switch Indicator	<p>When LOAD/UNLOAD switch pressed, one of the following occurs:</p> <ol style="list-style-type: none"> 1. Will produce a tape load to load point when the BOT tab is located at the BOT-EOT sensor. 2. Tape is searched forward approx. 30 feet. If BOT tab is not sensed, a rewind to load point occurs. 3. The tape is unloaded off the take-up reel when the tape is at load point.

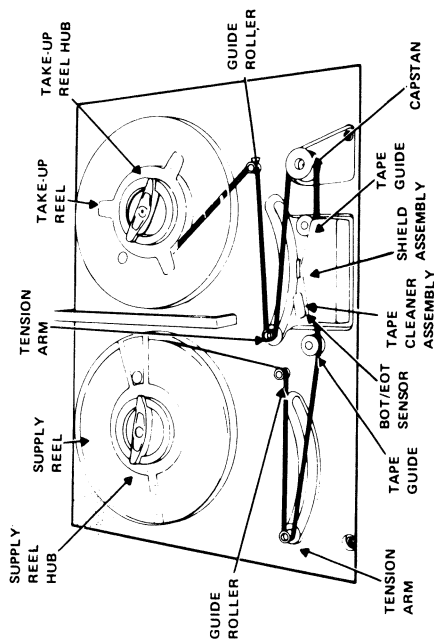

Figure B. Tape Threading Diagram

2181 AND 2182 MAGNETIC TAPE DRIVE

The Model 2181 is a 9-channel, NRZI, 800 bpi magnetic tape drive. The Model 2182 is a 9-channel, Phase Encoded, 1600 bpi magnetic tape drive. Each model is capable of reading and writing magnetic tape.

The recording medium for both models is 1/2-inch, computer-compatible magnetic tape.

Loading A Tape Reel

1. Open dust cover.
2. Check write enable ring on supply reel.
To prevent writing, remove ring.
For write operation, insert ring.
3. Mount supply reel.
4. Press POWER pushbutton (see Figure A).

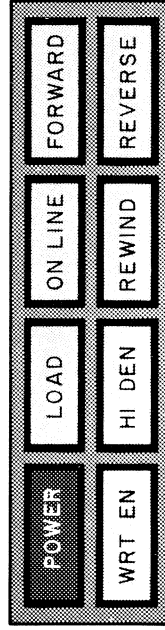

Figure A. Tape Drive Control Panel

5. Thread tape along path as shown in Figure B. Wrap several turns clockwise around the take-up reel. Check that tape is correctly seated on guides and properly threaded through photosensor and head assembly.

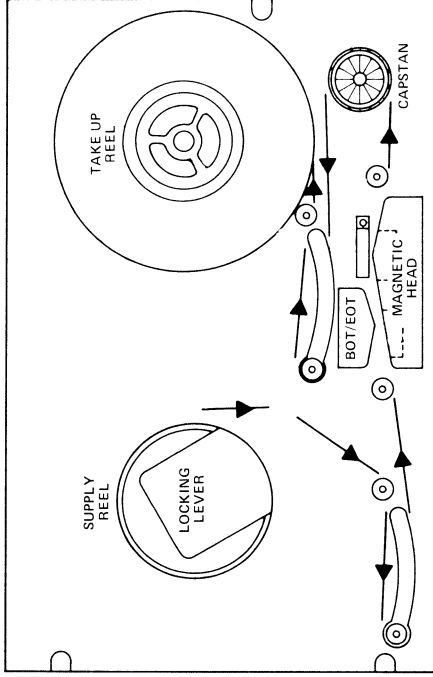

Figure B. Tape Threading Diagram

CAUTION

TENSION ARMS MUST BE IN REST POSITION AS SHOWN IN FIGURE B. BACK OFF TAPE IF NECESSARY.

6. Close dust cover.
7. Press LOAD pushbutton. Tape will be tensioned.
8. Press LOAD pushbutton again. Tape will advance until BOT is sensed. The LOAD indicator will illuminate when BOT is sensed.
9. Press ON LINE pushbutton.

NOTE:

To obtain Off-Line mode, press On-Line pushbutton. Notice that On-line indicator extinguishes. Perform Off-Line operation as required.

Unloading A Tape Reel

1. If power is off, press POWER pushbutton and proceed to Step 2. If power is on, start with Step 3.
2. Press LOAD pushbutton. Tape will be tensioned.
3. Press REWIND pushbutton. If tape at LOAD POINT, tape will rewind until tension is lost. If tape not at LOAD POINT, rewind ceases when BOT is reached. Press REWIND pushbutton second time to complete unload sequence.
4. Open dust cover.
5. Release supply reel and remove reel of tape.
6. Close dust cover.

Table 1. Tape Drive Controls and Indicators

CONTROL OR INDICATOR	TYPE	FUNCTION	CONDITIONS
POWER	Alternate-Action Push-button/Indicator	Switches line power on and off. Illuminates red to indicate power is on.	Fuse installed. Line cord connected.
LOAD	Momentary-Action Push-button/Indicator	Initial actuation energizes motors and servo system and tensions tape. Second actuation advances tape to load point. Illuminates to indicate BOT tape is positioned at photo-sensor.	Power restored after being off, loss of tape tension. Motors and servo system energized. Tape tensioned by initial actuation.
ON LINE	Momentary-Action Push-button/Indicator	Switches drive to on-line mode. Illuminates to indicate transport is on line. Second actuation switches transport off line. Indicator extinguished to indicate transport is off line.	Initial Load or Rewind actuation. Transport is in off-line mode (ON LINE indicator extinguished). Drive is on-line mode. (ON LINE indicator illuminated).

Table 1. Tape Drive Controls and Indicators (Cont'd.)

Control or Indicator	Type	Function	Conditions
REWIND	Momentary-Action button/Indicator	Rewinds tape to load point. REWIND indicator illuminates during rewinding, then goes out. LOAD indicator illuminates to indicate BOT tab is positioned at photosensor. Second actuation or REWIND pushbutton unloads tape.	Transport in off-line mode. (ON LINE indicator not illuminated). Tape reel with write enable ring installed.
WRT EN (Write Enable)	Indicator	Illuminates to indicate write function may be performed.	Tape reel with write enable ring installed mounted on supply hub.
HI DEN (High Density)	Alternate-Action button/indicator	Selects read density. Illuminates to indicate high-density mode is selected.	
FORWARD	Alternate-Action button/Indicator	Start-stops tape forward motion. Illuminates to indicate drive in forward mode.	Transport in off-line mode (ON LINE indicator extinguished).
REVERSE	Alternate-Action button/indicator	Start-stops tape reverse motion. Illuminates to indicate drive in reverse mode.	Transport in off-line mode (ON LINE indicator extinguished).

MDS DATA-RECORDER — SERIES 21 INTERFACE

INTRODUCTION

Series 21 Data-Recorder Interface provides a means of using computer-compatible magnetic tape as input to, or output from, Series 21. The 1103 and 6403 Data-Recorders and 7505 Controller (7 or 9 track) are supported on Series 21.

Series 21 and the Data-Recorder are physically connected through the communication controllers of each device, via a switchable cable. This switching mechanism allows the Data-Recorder to be used with Series 21 or as a standard MSC communications device.

Series 21 software treats the Data-Recorder/7505 Controller as if it were a Mag. Tape Drive. However, some mag. tape drive operations, such as rewind, tape mark (TM) detection and write TM, must be done manually by the operator on the Data-Recorder, rather than automatically using the Series 21 software.

IMPORTANT

With the Series 21 Data-Recorder Interface,

- maximum allowable Data-Recorder record length is 120 characters.
- to successfully transfer data, the Data-Recorder/7505 must be ready in all respects prior to initiation of data transfer from or to the Series 21. This means:
 - a. A suitable program must be loaded in the Data-Recorder,
and
 - b. The tape must be ready and, in the case of transferring data to Series 21, the first record must be read into the Data-Recorder memory.

Pre-Operation Procedures

LOADING TAPE REELS (all models)

1. Open dust cover.
2. Mount supply tape reel.
 - a. Hold reel so that tape feeds to the right.
 - b. Place reel over hub and push in firmly until the reel snap-locks in place.
3. Thread tape according to diagram for your Data-Recorder model:

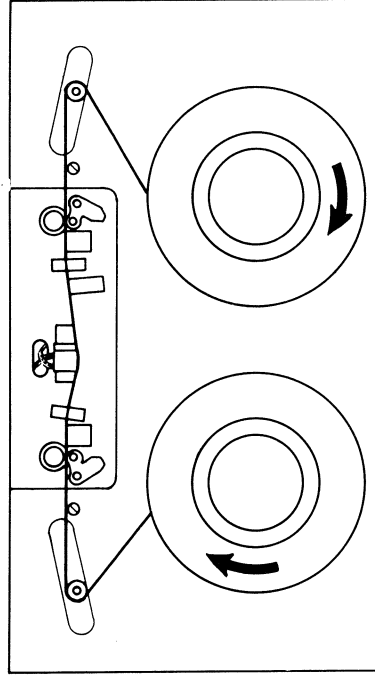

7505 TAPE FEED

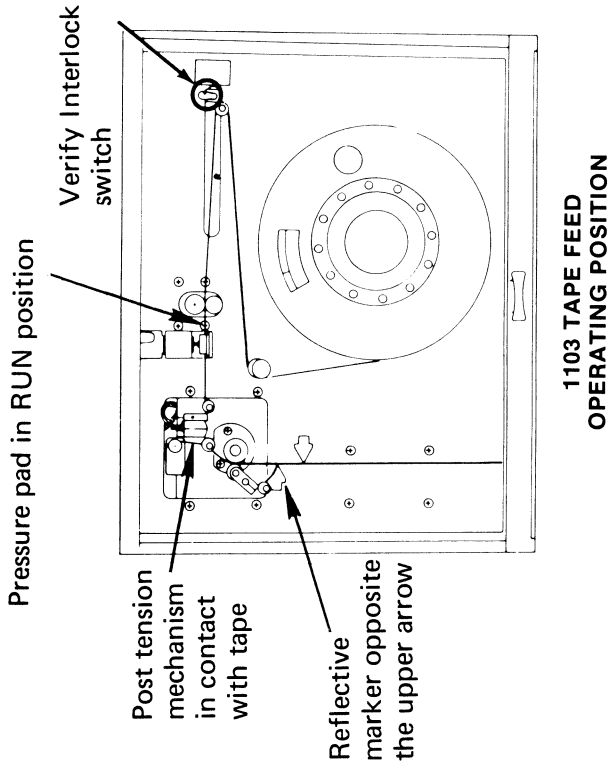

1103 TAPE FEED
OPERATING POSITION

Pressure Pad in Rewind Position

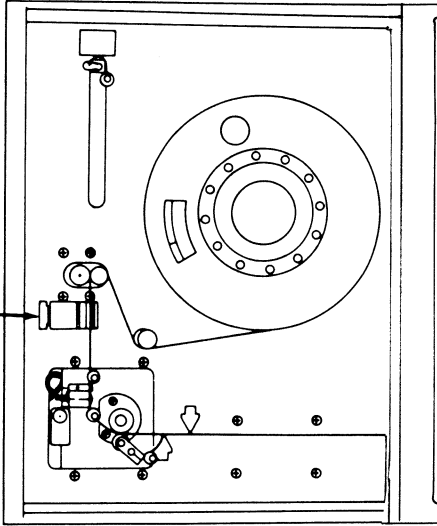

**1103 TAPE FEED
REWIND POSITION**

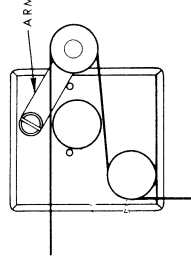
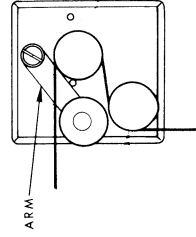
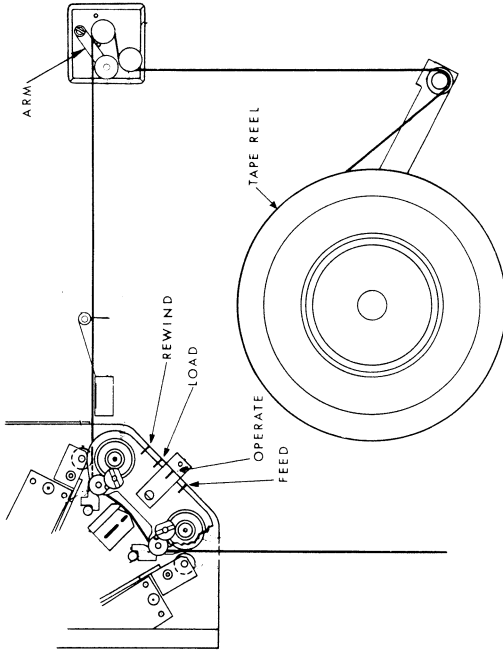

6403 TAPE FEED

Using the Series 21 Data-Recorder Interface for Data Transfer

Operating procedures for each Data-Recorder supported by Series 21 Interface vary to some degree. Determine which of the following procedures apply to your installation, and have available the reference material that pertains to your Data-Recorder.

Be sure to read all procedures, including **ERROR CONSIDERATIONS** (p. 47, this publication), before attempting a data transfer operation.

1103 DATA-RECORDER

To Transfer Data From Series 21 to 1103:

- A. Data-Recorder Setup:
- Follow procedures for 1103 Data-Recorder to ensure that appropriate program is loaded in the 1103 core memory. (See MDS publication M-1936.)

- Mount and thread tape.

- Set Control Panel Switches:

MS (Memory Select)	—	DATA
M (Mode)	—	ENTRY
R (Release)	—	OFF
D/S2 (Dup/Skip)	—	OFF
V/INT (Verf. Interlock)	—	OFF

- Reset Block Counter to zero.

- Set Keyboard Switches:

SEND/REC	—	REC
ON/OFF	—	ON
O - E	—	ODD Light ON
D/S 1	—	OFF

- B. Series 21 Setup:

- Data-Recorder Setup must be complete through Step 5 above.
- Load MDS Media Utilities program (MCV).

- Use DATA SET LABEL function of MCV to ensure that the data set to be transferred is the appropriate record size.

NOTE:

Series 21 and Data-Recorder record sizes must be the same. Therefore, programmers at your installation should be certain that the Series 21 record length corresponds with your 1103 record length.

- Select COPY function of MCV. Select INPUT device containing data set to be transferred.
 - Select MAG TAPE as OUTPUT device.
- C. Series 21 to 1103 Data Transfer:
- When Step 5 of Series 21 Setup is executed, data transfer from diskette to mag tape begins immediately and will continue until EOD (end of data) is sensed on diskette.
 - The message WRITE TM is displayed on line No. 2.
 - Ensure that block counts agree.
 - If not, restart Data Transfer operation and retry. An incomplete Data Transfer may have occurred because of a timeout situation.

b. If block counts agree, Data Transfer operation is complete.

4. Follow appropriate procedures for 1103 Data-Recorder to respond to WRITE TM message.

NOTE:

Several TEF's (tape erase forward) can be performed in lieu of TM on the 1103.

To Transfer Data From 1103 To Series 21:

A. Data-Recorder Setup:

1. Follow procedures for 1103 Data-Recorder to ensure that appropriate program is loaded in the 1103 core memory. (See MDS publication M-1936.)

2. Mount and thread tape containing data to be transferred.

NOTE:

Since no Tape Mark is available from 1103, multiple TEF (tape erase forward) should be performed by the Data-Recorder operator following the useable data. This will cause a "READ ERROR" condition to be sensed by the Series 21, and thus effect an EOF (End of File).

3. Set Control Panel Switches:

MS	—	DATA
M	—	VERIFY
R	—	ON
D/S 2	—	OFF
V/INT	—	ON

4. Reset Block Counter to zero.

5. Read first record into data memory using REL key.

6. Set Control Panel RELEASE switch OFF.

7. Set Keyboard Switches:

SEND/REC	—	SEND
ON/OFF	—	ON
O - E	—	ODD Light On
D/S 1	—	OFF

B. Series 21 Setup:

1. Data-Recorder Setup must be complete through Step 7 above.

2. Load MDS Media Utilities program (MCV).

3. Use DATA SET LABEL function of MCV to ensure that the data set allocated to receive the data is available and that record size is the same as that for the Data-Recorder.

4. Select COPY function of MCV. Select MAG TAPE as INPUT device.
 5. Select OUTPUT device (may be DISKETTE or DISK).
 6. Enter the Data Set Name of the data set that will receive OUTPUT.
- C. 1103 Series 21 Data Transfer:
1. When Step 6 of Series 21 Setup is executed, data transfer from mag tape to diskette (or disk) begins immediately and will continue until EOF is sensed on tape. (See NOTE following Step A.2., above.)
 2. Ensure that block counts agree.
 - a. If not, restart Data Transfer operation and retry.
An incomplete Data Transfer may have occurred because of a timeout situation.
 - b. If block counts agree, Data Transfer operation is completed.

6403 DATA-RECORDER

To Transfer Data From Series 21 to 6403:

- A. Data-Recorder Setup:
1. If Data-Recorder is equipped with Selective Block Length Device, adjust the thumb wheel to correct setting. (Example: Data blocks of 80 positions require a dial setting of 08; 160-character blocks, 16.)
 2. Follow procedures for 6403 Data-Recorder to ensure that appropriate program is loaded in the 6403 core memory. (See MDS Publication M-1758.)
 3. Set switches:

Auto Skip/Dup	—	OFF
Release	—	REL
Prog Load	—	OFF
Mode	—	VERIFY
Search	—	OFF
Program	—	NORMAL
Operate	—	OFF
Image Mode	—	ON
 4. Mount and thread tape. Remove Write Enable Ring.
 5. Perform Tape Feed Operation.
 6. Depress ER key to acknowledge Error Light.
 7. Reset Block Counter to zero.

8. Read the first data block into Data-Recorder memory using the REL key.
9. Change switches:

Release	—	OFF
Operate	—	Operate On Line
Send/Receive	—	SEND
Odd/Even Ind.	—	ODD
10. Depress ER/HOME keys.
 - B. Series 21 Setup:
 1. Follow procedures Steps 1-5 given for Series 21 Setup for the 1103 Data-Recorder for transfer from Series 21 to Data-Recorder (page 40).
 - C. Series 21 to 6403 Data Transfer
 1. When Step 5 of Series 21 Setup is executed, data transfer from diskette to mag tape begins immediately and will continue until EOD is sensed on diskette.
 2. The message WRITE TM is displayed on line #2.
 3. Ensure that block counts agree.
 - a. If not, restart Data Transfer operation and retry. An incomplete Data Transfer may have occurred because of a Time Out situation.

b. If block counts agree, Data Transfer operation is complete.

4. To write Tape Mark on mag. tape:

a. Change switches on 6403 as follows:

IMAGE MODE — OFF
 OPERATE — OFF
 Release — ON

b. Toggle W/TM switch.

To Transfer Data From 6403 to Series 21:

A. Data-Recorder Setup:

1. If Data-Recorder is equipped with Selective Block Length Device, adjust the thumb wheel to correct setting.

2. Follow procedures for 6403 Data-Recorder to ensure that appropriate program is loaded in the 6403 core memory (See MDS Publication M-1758.)

3. Set Switches:

Auto Skip/Dup — OFF Program — NORMAL
 Release — REL OPERATE — OFF
 Prog Load — OFF IMAGE MODE — ON
 Mode — VERIFY
 Search — OFF

4. Mount and thread tape. Remove Write Enable Ring.

5. Perform Tape Feed operation.

6. Depress ER key to acknowledge Error Light.

Reset Block Counter to zero.

8. Read the first data block into Data-Recorder memory using the REL key.

9. Change switches:

Release — OFF
 OPERATE — OPERATE ON LINE
 SEND/RECEIVE — SEND
 ODD/EVEN IND — ODD

10. Depress ER/HOM keys.

B. Series 21 Setup:

1. Follow procedures 1-6 given for Series 21 Setup for the 1103 Data-Recorder for transfer from Data-Recorder to Series 21 (pages 41-42).

C. 6403 to Series 21 Data Transfer

1. When Step 6 of Series 21 Setup is executed, data transfer from mag. tape to diskette (or disk) begins immediately and will continue until TM is sensed by the 6403; this triggers termination of the data transfer operation.

2. Check Block Counts. The 6403 Block Count should be one greater than that of the Series 21.

7505 CONTROLLER

To Transfer Data From Series 21 to 7505:

- A. 7505 Setup:
1. Select Block Length using the thumb wheel of the Selective Block Length Device.
 2. Reset Block Counter to zero.
- NOTE:**
Be sure Communications switch is OFF.
3. Ensure that Input program is loaded. (See MDS Publication M-1760).
 4. Ready the 7505 Magnetic Tape Unit. Load tape that is to receive data to be transferred.
 5. Enter any required Tape Marks or Labels.
 6. Press ER/HOM to ensure address is at position 001.

7. Set switches:

START/STOP	—	START
KEYBD	—	OFF
TAPE	—	WRITE
SEARCH	—	OFF
AUTO SKIP/DUP	—	OFF
PROG LOAD	—	OFF

Data-Recorder — (Series 21 Interface) continued

8. Set Communications switches:

ON/OFF	—	ON
SEND/RECEIVE	—	RECEIVE
OM/EM Ind.	—	OM
IMAGE MODE	—	ON (9 track); OFF (7 track)

B. Series 21 Setup:

1. Follow procedures 1-5 given for Series 21 Setup for the 1103 Data-Recorder for transfer from Series 21 to Data-Recorder (page 40).

C. Series 21 to 7505 Data Transfer:

1. When Step 5 of Series 21 is executed, data transfer from diskette to mag tape begins immediately and will continue until EOD is sensed on diskette.
2. The message WRITE TM is displayed on line No. 2.
3. Ensure that block counts agree.
 - a. If not, restart Data Transfer operation and retry. An incomplete Data Transfer may have occurred because of a Timeout situation.
 - b. If block counts agree, Data Transfer operation is complete.

4. To write Tape Mark on mag tape, change switches as follows:

KEYBD	—	ON
C/TM - W/TM	—	W/TM

To Transfer Data From 7505 to Series 21:

A. 7505 Setup:

1. Select correct Block Length using the thumb wheel of the Selective Block Length Device.
2. Reset Block Counter to zero.

NOTE:

Be sure Communications switch is OFF.

3. Ensure that Output program is loaded.

4. Ready the 7505 Magnetic Tape Unit. Load tape containing data to be transferred.

NOTE:

For tape, Header Labels or Tape Marks may be bypassed by using the REL key.

5. Read the first data block into 7505 memory.

6. Press ER/HOM keys to ensure that address is at position 001.

7. Set switches:

KEYBD	—	OFF
TAPE	—	READ
SEARCH	—	OFF
AUTO SKIP/DUP	—	OFF
STOP/START	—	START

8. Set Communications switches:

ON/OFF	—	ON
SEND/RECEIVE	—	SEND
OM/EM	—	OM
IMAGE MODE	—	ON (9 track); OFF (7 track)

B. Series 21 Setup:

1. Follow procedures 1-6 given for Series 21 Setup for the 1103 Data-Recorder for transfer from Data-Recorder to Series 21 (pages 41 and 42).

C. 7505 to Series 21 Data Transfer:

1. When Step 6 of Series 21 Setup is executed, data transfer from mag tape to diskette (or disk) begins immediately and will continue until TM is sensed by the 7505; this triggers termination of the data transfer operation.

2. Ensure that block counts agree.

- a. If not, restart Data Transfer operation and retry.
An incomplete Data Transfer may have occurred because of a Timeout situation.
- b. If block counts agree, Data Transfer operation is completed.

TIMEOUT

Operational or hardware problem has delayed beginning of transfer more than 20 seconds.

ERROR CONSIDERATIONS

When any unrecoverable error occurs, the Data Transfer operation should be restarted.

The following messages provided by the Series 21 software may appear on the display screen:

Message	Meaning
PARITY ERROR	1. Possible hardware malfunction, or 2. Inconsistent record sizes.
RECORD SIZE ERROR	A Series 21 record size was selected that was not a multiple of 10 characters.

NOTE:

Largest Series 21 record that can be used is 120 characters.

2172 DISK DRIVE

The Model 2172 is a high-density single disk drive (IBM 2315 equivalent) providing more than 2 million bytes of on-line storage. The recording medium is a 15-inch diameter disk which rotates at a rate of 1500 rpm. Data is recorded on up to 406 data tracks by means of two movable magnetic read/write heads.

Loading a Disk Cartridge

1. Insure that disk power cable and interface cable are properly connected.
Verify that the LOAD indicator is illuminated (see Figure B).
2. Open the disk access door and insert the disk cartridge.
See Figure B for proper orientation of the disk cartridge prior to installing in the receiver.
3. Close the disk access door.

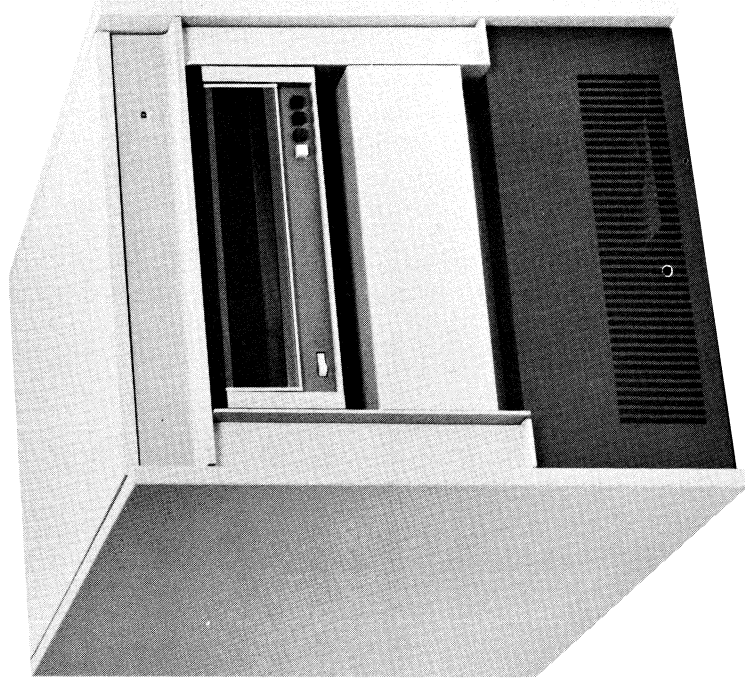

FIGURE A. DISK DRIVE FRONT VIEW

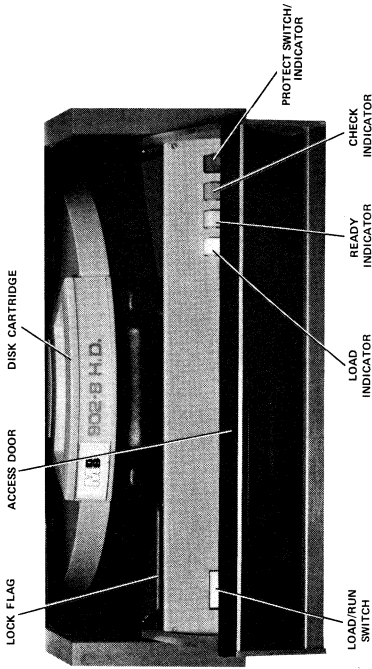

FIGURE B. DISK DRIVE INDICATOR

CAUTION

WHILE THE DISK IS ROTATING OR IF EQUIPMENT POWER IS SHUT DOWN, THE ACCESS DOOR IS NORMALLY LOCKED. NEVER ATTEMPT TO FORCE THE ACCESS DOOR OPEN.

4. Position the LOAD/RUN switch (see Figure B) to the RUN position. After approximately 3 minutes, verify that the READY indicator illuminates and the LOAD indicator extinguishes.

5. Observe the condition of the PROTECT indicator. If illuminated, writing to the disk is prohibited.

Unloading a Disk Cartridge

1. Verify that power is applied.
2. If the READY indicator is illuminated, position the LOAD /RUN switch (see Figure B) to the LOAD position. After approximately 3 minutes, verify that the LOAD indicator illuminates, then perform Steps 4 and 5.
3. If the LOAD indicator is illuminated, proceed to Step 4.
4. Open the disk access door and remove the disk cartridge.
5. Close the disk access door.

Table 1. Indicators

Indicator	Function
LOAD	Indicates that the disk cartridge can be removed.
READY	Heads loaded and disk up to speed.
CHECK	Seek error, hardware-detected.
PROTECT	Writing to disk prohibited.

COMPATIBLE CHANNEL (Feature 180)

The Compatible Channel is an optional feature which enables the exchange of information between the Series 21 and an MDS System 1200, 2400 or 2300 (referred to as the external system). When in use, the Compatible Channel causes the Series 21 to appear as a magnetic tape drive to the external system's application program.

The two basic functions provided are read and write. If other tape commands are encountered they are either ignored, or treated as a no-op condition — which causes no concern, with the exception of diagnostic programs run on the external system, where all tape drive functions are expected.

System 1200/2300/2400 Programs

Most MDS-supplied software packages (including communications emulators) that support a magnetic tape drive as an I/O device may be used without modification. When 2400 MDL programs are used, the MDL IOD statement nine track TAPE addresses the Series 21 as a tape drive, via the Compatible Channel. The Select Code used to address the Series 21 is switch-selectable, and is set as desired by your MDS Field Service Engineer when the system (or feature) is installed.

Operation

The Compatible Channel is only available when using MEDIA UTILITIES — Copy Function, or MOBOL-written User Applications programs with appropriate read/write commands.

Typical Applications Using the Compatible Channel

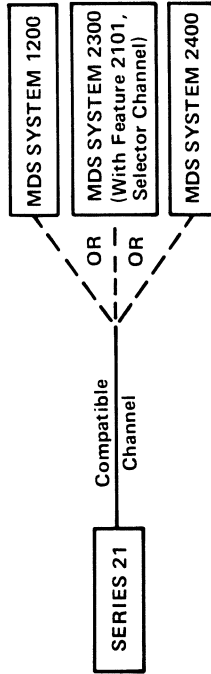

AS AN OUTPUT DEVICE FROM THE HOST PROCESSOR

— The Series 21 accepts information from the external system and records information on its selected OUTPUT DEVICE (which cannot be the Compatible Channel).

AS AN INPUT DEVICE TO THE HOST PROCESSOR

The Series 21 reads information from its selected INPUT DEVICE, and information is transferred to the external system via the Compatible Channel. (In this mode the INPUT DEVICE cannot be the Compatible Channel).

All other operation is under control of the program that is in use in the Series 21 and external system.

PROBLEM DETERMINATION

Use this section to isolate a problem, determine its probable cause, and corrective action. When in doubt of the recovery required, and recovery procedures cannot be found in the particular section you are using, CONSULT THIS SECTION FIRST before running a System Confidence Tests or calling MDS for service.

This section includes information on the following:

Title	Page
CONTROLLER CONSOLE	2
DISPLAY SCREEN PROBLEM	3
MESSAGES DURING PROGRAM LOAD	5
DISKETTE, POSSIBLE DEFECTS	9

NOTE:

All error and status messages are documented, with recovery procedures, in the *Series 21 Display Messages Manual for Rel. 7.0*, Form No. M-3925.

CONTROLLER CONSOLE



POWER

OPERATOR PANEL ON CONTROLLER CONSOLE

RESET

<p>PROBLEM</p> <p>PRESSING POWER SWITCH DOES NOT POWER UP THE CONTROLLER CONSOLE, AND DOES NOT LIGHT THE POWER SWITCH.</p>	<p>PROBLEM</p> <p>THE RESET SWITCH ILLUMINATES RED AND STAYS ON.</p>
<p>RECOVERY</p> <p>1. Check the circuit breaker in the rear of the Controller Console to insure that it is ON.</p> <p>2. Insure the Controller Console is plugged in.</p> <p>3. Have qualified local maintenance personnel insure there is voltage at the A.C. receptacle you are using.</p> <p>4. If the problem is not caused by your A.C. receptacle, call MDS for service.</p>	<p>RECOVERY</p> <p>TURN CONTROLLER CONSOLE POWER OFF (THE SYSTEM MAY AUTOMATICALLY POWER OFF, SINCE THIS IS AN INDICATION OF INTERNAL OVER-HEATING).</p> <p>1. Perform the "Air Filter Removal & Replacement" Procedure provided in the MAINTENANCE section of this manual.</p> <p>2. If, after changing the air filter the red indicator in the RESET switch remains on, call MDS for service.</p>
<p>PROBLEM</p> <p>THE RESET SWITCH ILLUMINATES WHITE AND STAYS ON.</p>	<p>PROBLEM</p> <p>TURN CONTROLLER CONSOLE POWER OFF (THIS INDICATES A POWER SUPPLY MALFUNCTION).</p> <p>1. Call MDS for service.</p>

DISPLAY SCREEN

DISPLAY SCREEN	PROBLEM	WHAT TO DO
	Blank Screen	<ol style="list-style-type: none">1. Check the indicator on the front panel of the display screen. If it is on, go to Step 3; if it is off, go to Step 2.2. Insure that the operator station is plugged in, and the operator station power switch is ON.3. Insure that the controller console is ON, and that a program is loaded.4. Turn the brightness control on the operator station front panel to the right.5. If the problem is not resolved, and another operator station is available, run the System Confidence Test and report the results to MDS.
	Display too Bright	<ol style="list-style-type: none">1. Turn the brightness control on the operator station to the left.

DISPLAY SCREEN (Cont'd.)

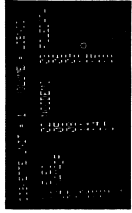
DISPLAY SCREEN	PROBLEM	WHAT TO DO
	<p>Display too Dark</p>	<ol style="list-style-type: none"> 1. Turn the brightness control on the operator station to the right.

NOTE: IF AT ANY TIME A STEADY "BEEPING" SOUND IS HEARD, AND THE SYSTEM WILL NOT ACKNOWLEDGE KEY DEPRESSIONS, CHECK FOR THE FOLLOWING:

- KEYBOARD KEY STUCK IN THE DOWN POSITION
- STROBE SWITCH IN THE REAR OF THE OPERATOR STATION MUST BE IN THE DOWN POSITION

DISKETTE, POSSIBLE DEFECTS

When a possibly defective diskette has been detected, the following steps are recommended:

1. Check diskette appearance:
 - a. Inspect diskette for any signs of excessive wear or damage.
 - b. Inspect the center hole and ensure that it is not elongated or worn out of shape.
 - c. Carefully rotate the diskette, visually checking the recording surface. Ensure that index hole is unobstructed and not damaged.
2. Check the diskette on a system:
 - a. Check each diskette in more than one diskette drive.
 - b. Load the CEOIF (Confidence Test) program, using JCL to enter the following:

JCL string LO5/X501/X508/*

1. LO5 — Load flex disk test
2. X501 — execute subtest 01
3. X508 — execute subtest 08

- c. Remove the CEOIF diskette from the first diskette drive and insert the diskette in question.

- d. Answer 'Y' (yes) to the prompt TEST IPL DRIVE?.
- e. Diskette will be read 512 times if test is allowed to continue. After the test cycle count has gone from zero (0) to one (1), test cycle may be halted by pressing SEL MODE.

NOTE:

With CEOIF loaded, additional questionable diskettes may be checked by repeating procedures c, d and e.

- f. If no failures are reported, all sectors and tracks are accessible.

NOTE:

If problems persist, it may be because the information recorded on the diskette is incorrectly formatted.

3. Report findings of diskette test(s) to MDS representative when calling to report possible hardware problem.

SYSTEM CONFIDENCE TEST

System Confidence Test Operation

This procedure is provided by MDS for the following reasons:

- To test your system prior to the start of a live data processing operation. In this way, many of the possible work-stoppage situations will be discovered before a job is begun, forestalling a disruption of the job. The test will alert you to such things as an Operator Station which has not been made ready, a printer which is out of paper, or a malfunction which will require a service call.
- To provide you with a means of reporting any problems in a manner more easily understood by your servicing CE, enabling the CE to effect a more efficient repair of the system.

IMPORTANT

IF ANY PROBLEMS ARE ENCOUNTERED DURING TEST, REFER TO STEP NO. 9.

1. Prepare all devices as follows, ensuring that they are plugged in and turned on:
 - a. Remove any program diskettes from all diskette units.
 - b. If you have a removable disk drive, insert a scratch disk.

2. If you have communications, place the NORMAL/TEST switch (on the MODEM CABLE where it connects to the MODEM) in TEST position.
3. If you have a printer, see that it is ON LINE, and has paper and a ribbon installed.
4. If you have a tape drive, mount a scratch tape (with a ring), and see that it is in REMOTE.
5. Insert SYSTEM CONFIDENCE TEST diskette into any diskette unit.
6. Press the RESET button on the Controller Console.
7. Within 10 seconds, the message 'LOADING' appears on the screen at Operator Station 1.
8. In less than a minute, the Test Display appears on all Operator Station screens, accompanied by a 15-second tone allowing adjustments of brightness and loudness controls.

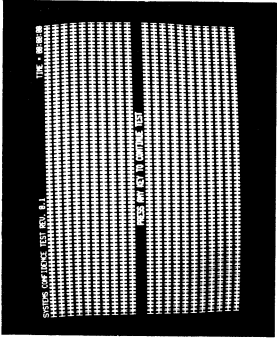

Test Display

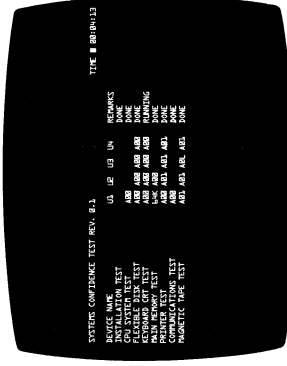

Sample Display

6. Remove the SYSTEM CONFIDENCE TEST diskette, and insert a scratch diskette into all diskette units.
7. Press any key on any Operator Station keyboard. The test will begin, and all screens will have a display similar to the SAMPLE DISPLAY. Press at least one key at each Operator Station during test. Within 10 minutes (perhaps longer for very large systems), the display should exactly match the SAMPLE DISPLAY, indicating that the system is ready for normal operation. make an entry in the System Log; 'Confidence Tested'.

8. If you have communications, ensure that the NORMAL/TEST switch is in the NORMAL position, and return to normal operations.
9. If any difficulties are encountered during the test, search the following list until the problem definition is found, and take appropriate action. If the action results in a work-stoppage situation, enter 'work-stoppage' in the System Log along with other applicable entries, and be sure to call and convey all Log entries to the CE office, work-stoppage or not.
 - a. A device will not power up, go ON-LINE or into REMOTE. Make your Log entry. If you can run a job without the device, continue with the test.

- b. Diskette won't stay in diskette drive, or the door won't latch shut. Make your Log entry, and use another diskette unit, if available, to continue the test.

- c. Diskette will not eject from the diskette unit. Enter "Work-stoppage" on the Log. Refer to Step 9.
- d. A blank display on an Operator Station screen. Be sure brightness is turned up. If display remains blank, make your Log entry and turn that Station off. Continue test if you have other Operator Stations.
- e. Display = CHECK 1 or CHECK 2. Depress RESET again. If either display returns enter the display and 'work-stoppage' in the Log.
- f. Display = CHECK 3 or CHECK 4 or PHASE 1 or a cycling display (e.g. LOADING, then CHECK 3, then PHASE 1) or an unintelligible display.
Carefully repeat Steps 1, 2, and 3, ensuring that the SYSTEM CONFIDENCE TEST label faces to your right. If any of these displays return, try another SYSTEM CONFIDENCE TEST diskette (if you have a spare). If not, log the diskette unit out, and enter the display, and try another diskette unit if you have one. If not, enter "work-stoppage".
- g. Display = FAULT — Enter 'FAULT' in the Log along with all lines on the display, in their entirety, if they contain a 'C . . .' under any Ux column. This is a work-stoppage situation.
- h. Display contains a 'C . . .' under Ux column for the INSTALLATION TEST, CPU SYSTEM TEST, or MAIN MEMORY TEST. This is a 'work-stoppage'. Enter, in the system Log, the entire line(s) of the bad display line(s) along with any other line(s) containing a 'C . . .' or 'B . . .' under Ux column.
- i. Display contains a 'C . . .' under any Ux column for tests other than those mentioned in Step h. Enter, in the System Log, the entire display line(s) containing the 'C . . .' as well as any containing a 'B . . .'. If you can operate without the unit(s) in question, continue below.
- j. Display — 'B00', 'B01', or 'B02'. Enter the entire line(s) in the System Log, replace the disk or tape in/on the unit in question, mark the disk or tape 'questionable', and go to 1.
- k. Display = 'Bxxx', any other 'B . . .' besides those mentioned in j. Log the entire line(s) and continue below.
- l. Display = 'Axx'; any other 'A . . .' besides the ones shown in the Sample Display. Respond according to the following list, and do not phone in the problem unless the display returns.
- A01 — This unit would not respond. Ensure that the unit is ready for operation and go to Step 1.
- A02 — Not ready or COMM switch is not in TEST. Correct and go to Step 1.
- A03 — Not ON LINE. Correct and go to Step 1.

A04 — Unit is write-protected. Besure unit houses a scratch tape or disk, remove ring or write protect the diskette, and go to Step 1.

A05 — or A06 or A07 — Memory test is still running. If more than 10 minutes passes and the display does not change to A00, log the entire line and 'work-stoppage'.

A10 or A11 — Check the printer(s) for paper and ribbon and ensure that the cover is not open. Return to Step 1.

m. Any display not listed? Log the entire display and 'work-stoppage'. See Step 9.

MAINTENANCE

This section describes the maintenance and cleaning procedures that may be performed by the Series 21 operator.

The following information is provided:

	Page
CLEANING CONTROLLER CONSOLE & OPERATOR STATION	2
AIR FILTER REMOVAL & REPLACEMENT	3
CLEANING THE 2181/2182 MAG TAPE DRIVE	5

CLEANING THE CONTROLLER CONSOLE AND OPERATOR STATION

Precautions:

1. Remove all diskettes from the system and from the immediate area when cleaning the system.
2. Spray waxes and oils are not recommended.
3. Close all diskette access doors when cleaning the system.

The glass face of the display screen may be cleaned with a lint-free cloth dampened with non-abrasive glass cleaner.

Periodically remove dust with a lint-free cloth. Do not apply spray cleaners directly on keyboard.

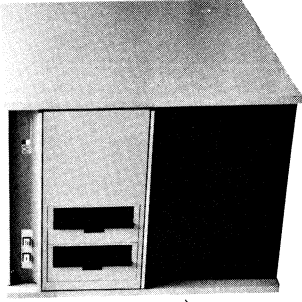
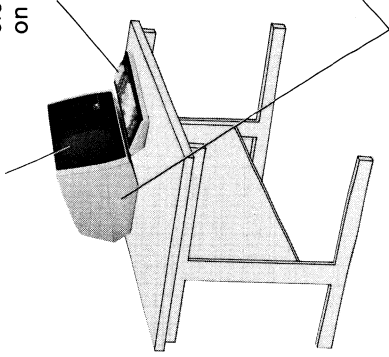

External surfaces may be cleaned with a lint-free cloth moistened with a mild soap-water solution. Do not apply spray cleaners directly.

AIR FILTER REMOVAL & REPLACEMENT

When To Change the Controller Console Air Filter

The Air filter should be changed:

- IF THE RESET SWITCH ON THE CONTROLLER CONSOLE LIGHTS RED. TURN POWER OFF IMMEDIATELY.
- or
- AFTER 6 TO 12 MONTHS OF OPERATION IN A NORMAL OFFICE ENVIRONMENT.
- or
- MORE FREQUENTLY IN ENVIRONMENTS CONTAINING DUST, SMOKE, OR OTHER CONTAMINANTS.

4. Press the air filter (as indicated in Figure B) down and out of the cover. Note the direction of the arrow on the filter before removing.

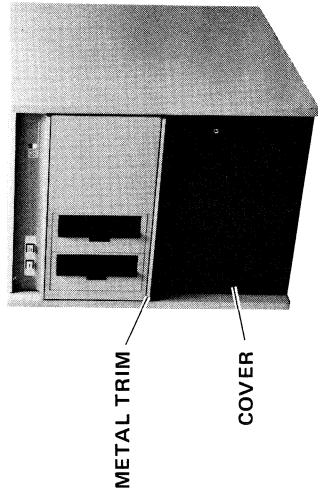

FIGURE A

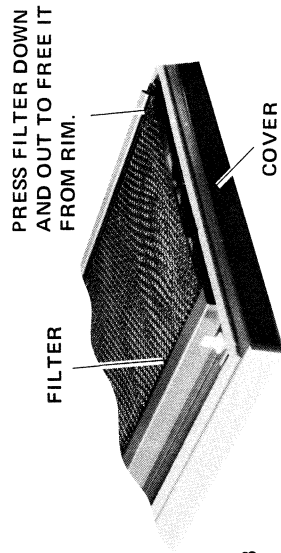

FIGURE B

How To Remove and Replace the Air Filter

CAUTION

TURN CONTROLLER CONSOLE POWER OFF PRIOR TO PERFORMING THIS PROCEDURE.

1. Place a newspaper or dropcloth on the floor against the front of the Controller Console.
2. Grasp the metal trim with both hands and pull the cover firmly towards you until the cover unsnaps. (See Figure A).
3. Lift the cover up and out, then place it on the newspaper or dropcloth.

5. If you have a throw-away filter, discard it. If you have a reusable filter, set it aside for future use.
6. Insert a spare filter into the cover, by pushing it back and down. Insure the arrow points away from the cover.
7. Replace the cover on the Controller Console.
8. Enter "Air Filter Replaced", and the date in the System Log, along with any other pertinent Log information.

IMPORTANT

NEVER OPERATE THE SYSTEM WITHOUT AN AIR FILTER.

CLEANING THE 2181/2182 MAG. TAPE DRIVE

Precautions:

1. Ensure that Power is OFF (indicator not lit).
2. Remove tape reel from drive if present.

3. Clean components (G), (H), (I), (J), and (K) as follows:
 - a. Raise ferrite shield (G), then clean entire top surface of the magnetic head (H).
 - b. Clean the perforated surface of the tape cleaner (I).
 - c. Use a lintless cloth to wipe entire surface of the capstan.
4. Close dust cover. (K)

- Daily Maintenance:**
1. Open dust cover.
 2. Using a Q-tip cotton swab wetted with Freon TF cleaner, clean the tape path components (A) through (E). (Refer to illustration below.)

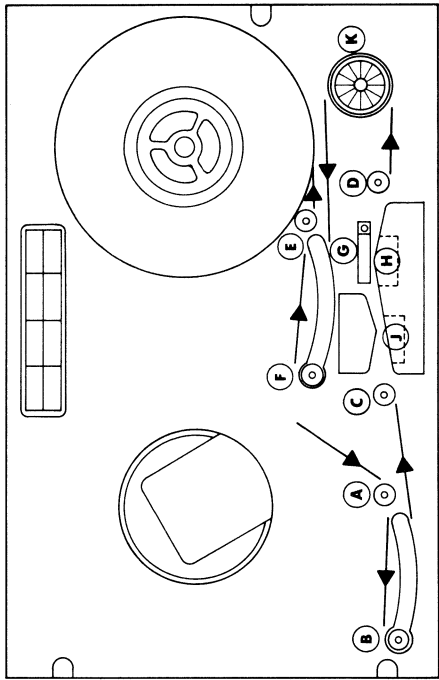

NOTES

NOTES

NOTES

NOTES

GLOSSARY OF TERMS

- Accumulator* — A system defined area designated for true addition (+) or zero balancing (-) during Entry, Verify or Update.
- Allocation* — The process of reserving an area on diskette or disk for a data set. Data set areas are defined in the VTOC by specifying the number of sectors for each data set name.
- Alphabetic* — Letters A through Z (upper or lower case) as entered through the keyboard or displayed on the video screen.
- Alphanumeric* — A record field which accommodates both alphabetic and numeric characters, as well as special characters.
- Application* — A type of problem or job which can be handled by data processing equipment.
- Automatic Field* — A field which is programmed either to be skipped or automatically duplicated (during entry or verify) without requiring operator action.
- Auxiliary Dup* — The process of automatically duplicating the information in a specific field whenever a designated program level is used.
- BOE* — Beginning of Extent; track and sector address identifying the start of a data set.
- BSC* — Binary Synchronous Communications; a widely accepted transmission procedure for communicating batches of data between dispersed sites. The most commonly used BSC protocols for batch transmission are IBM 2780 and 3780.
- Bypass Field* — A field programmed to be automatically skipped during entry or verify.
- Character* — The smallest portion of a field, consisting of a letter, number or special symbol occupying one record position.
- Check Digit* — A mathematical scheme using redundant digits to check the validity of numeric data being entered into specified fields of a record.
- Compiler* — A program-making routine which converts human-written, symbolic statements into executable object programs.
- Compressed Data* — Records that have been stripped of blank spaces, usually for purposes of data transmission or more compact storage on diskette, disk or magnetic tape.
- Confidence Test* — A disk-resident program which tests all system devices to ensure proper operation prior to production work.

Cursor — An illuminated reference point on a display screen, movable under program or operator control, which indicates the current position in a record to be acted upon.

Data diskette — A diskette used to store variable information, such as batches of keyed data for processing.

Data Set — A group of logically related, adjacent records on diskette or disk; sometimes referred to as a batch or file.

Data Set Name — The unique identifier assigned by an operator to differentiate one data set from another.

Data Set Number — The sequential position of a data set, relative to other data sets on the same diskette or disk.

Diskette — A thin, flat disk made of flexible plastic, coated with a magnetic recording material, used for data storage.

Dup Field — Constant information which is duplicated from record to record without requiring the operator to key the field each time.

Entry — The process of keying data from source documents to diskette.

EOD — End of Data; address of the next available sector of a data set.

EOE — End of Extent; last track/sector assigned to a particular data set.

FDE — Formatted Data Entry program; an MDS-supplied application program containing all the functions needed in a data capture environment.

Field — A portion of a record, consisting of one or more adjacent characters or spaces regarded as belonging together; for example, *Jane Doe* is a name field.

Function Key — A keyboard key used for system control purposes rather than to enter characters.

Hexadecimal — An abbreviated way of representing computer data, mostly used by programmers for analytical purposes.

Index Track — First track of a diskette; contains the VTOC to store control information regarding the contents of the diskette.

Job — A batch of related source documents which may be described and coded for computer processing.

Job Description — A definition of record layouts and other directives needed by the system to process a particular job.

JOBGEN — An MDS-supplied format used to create user-written job descriptions.

Label — A control record in the diskette index track giving the name and beginning/ending addresses of a data set. This is a "Data Set Label". It can also refer to the gummed labels on the diskette jacket identifying its contents.

Left Justify — The process of shifting keyed characters to the left-most boundary of a field and filling the unused positions with spaces.

Library Diskette — A diskette used to store programs.

Manual Field — A field in which the operator is expected to enter data.

Menu — A displayed list of functions which may be selected by the operator.

MOBOL — Mohawk Business Oriented Language, an MDS-supplied programming tool featuring English and symbolic statements for ease of application coding.

Modem — A modulating/demodulating device, obtained from the telephone company (or independent vendors), which converts computer data into appropriate signals for transmission over telephone lines.

Multi-Code (MC) — A key used to enter hexadecimal codes.

Multi-Volume Diskettes — Two or more diskettes containing the continuation of the same data set.

Numeric — Numbers 0 through 9, in any combination; for example, 690.

Numeric Pad — A separate group of keys on the keyboard, arranged like an adding machine, designed for rapid, numeric input.

Peripheral — An external device, such as a magnetic tape unit or disk drive, used to enter information into or receive data from the system.

Production Display — A display which shows the current status of work in progress.

Program — A series of human-written instructions which tell the system how to solve specific problems or process an application.

Program Level — Subdivision of a job description, defining the characteristics of a single document or record, its associated display and related keyboard procedures. A complete job may require up to 10 linked Program Levels. Each Program Level defines up to 20 data fields per 128-character record.

Prompt — A displayed message or name of a field used to guide the operator during system procedures.

Record — One or more consecutive fields of a source document which are regarded as a single unit; for example, *your* weekly time ticket is regarded by data processing as one record. A source record (depending on its length) may occupy more than one sector on diskette and may require several program levels to key.

Right-Justify — The process of shifting keyed characters to the right-most boundary of a field and filling the unused positions with zeros or spaces.

Search — The process of automatically locating a record in the system merely by entering a key name or character. Once located, the operator may examine and update the record.

Search Parameter — An identifying portion of a record on diskette or disk, used by an operator to locate and display one or more records. (Search Identifier).

Sector — The smallest addressable segment of a diskette or disk. On diskette, there are 1898 sectors, each containing up to 128 characters. For many applications, each sector holds one complete record.

Statistics — A performance monitor display that indicates the total number of keystrokes and corrections made by an operator.

Status — A display or printout which shows the current number of records that have been processed for each job.

Shift — The process of selecting (either manually or under program control) the characters which correspond to the upper and lower key top engravings on the keyboard.

System Confidence Test — See *Confidence Test*.

Track — One, complete circular recording path on diskette or disk, corresponding to each available position of the read/write head. A Basic Data Exchange diskette contains 74 tracks, each divided into 26 sectors.

Update — The process of correcting a previously keyed record on diskette by searching for and displaying the record.

Utility — Auxiliary routines which perform housekeeping chores to assist in processing a job. Some examples are: Labeling diskettes, positioning magnetic tape files and decompressing data communication records.

Verify — The process of rekeying previously recorded records (usually by a different operator) in order to be sure they match the original source documents.

VFU — Vertical Format Unit; the part of a printer which controls the line spacing and skipping required for formatted printing.

Volume ID — A record on the index track on diskette which identifies its name.

VTOC — Volume Table of Contents; written on the index track of a diskette, and containing the Volume ID as well as 1 to 19 Data Set Labels.

READER'S COMMENT FORM

Series 21 Operator's Guide, Form No. M-2611-1178

Please restrict remarks to the publication itself, giving specific page and line references with your comments when appropriate. This form will be sent to the publication's author for appropriate action. All comments and suggestions become the property of MDS.

Requests for system assistance or publications should be directed to your MDS representative or to the MDS branch office serving your area.

ERRORS NOTED: _____

SUGGESTIONS FOR IMPROVEMENT: _____

How do you use this document?

As an Operator's Reference Manual

As an introduction to the subject

As an aid to instruction in class

As a student text book

For advance knowledge of subject

Do you wish a reply?

Yes

No

Your Name _____ Date _____ Occupation _____

Company _____ Address _____

Street

City

State

Zip Code

BUSINESS REPLY MAIL

FIRST CLASS

PERMIT NO. 73

HERKIMER, N.Y.

POSTAGE WILL BE PAID BY ADDRESSEE

MOHAWK DATA SCIENCES CORP.

985 UNIVERSITY AVE.

LOS GATOS, CA. 95030



NO POSTAGE
NECESSARY
IF MAILED
IN THE
UNITED STATES

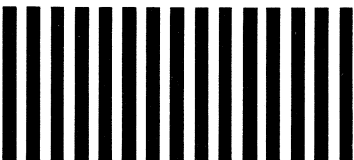

ATTN: TECHNICAL PUBLICATIONS DEPT.