

SONY.

Installation Manual
SDT-7000 Series

Ver.1.0

January, 1996

DDS Tape Drive

Sony Corporation

Table of Contents

Introduction 2

Product Features 2

Precautions 3

Installation 4

SCSI Connection / Setting the SCSI ID / Option Switches 4

Mounting Holes 5, 6

Orientation 7

Operation 8

Location of 3 LEDs 8

LED Indication for Drive Status 9

Drive Operation 10, 11

Interface Implementation 12

Supported SCSI Messages 12

Supported SCSI Commands 12

Specification 13

Product Specifications 13, 14

Third Party Support Contacts 15, 16

Sony Contacts 17

SDT-7000 DDS-2 Tape Drive

The Sony SDT-7000 drive is a high capacity data storage device using 4mm DAT (Digital Audio Tape) technology. The SDT-7000 drive achieves high data reliability through Read-After-Write, an additional level of Error Correction Code, and other features.

The Sony SDT-7000 drive stores data on tape using a standard format called DDS (Digital Data Storage), DDS-2, DDS-DC and DCLZ formats. These formats are used by numerous other DDS tape drive manufacturers, providing a broad range of compatible tape drives.

The Sony SDT-7000 is fully READ and WRITE compatible with the DDS-2 and DDS format tapes.

Introduction

Product Features

	SDT-7000 (With Data Compression)
Data Capacity	8 GB to 16 GB (Approx.)
Transfer Rate (sustained)	1556 to 3111 KB/sec (Approx.)

- Supported Formats: DDS, DDS-2, DDS-DC and DCLZ
- High Burst Transfer Rate- 5MB/sec Asynchronous
10MB/sec Synchronous
- Large 1MB Buffer
- 3.5" Standard Height, 5.25" Half Height
- Embedded SCSI Interface
- Supports Variable or Fixed Record Length
- Supports SCSI-2 Sequential-access Devices Command Set
- Read After Write (RAW)
- Frame Rewrite Function
- Three Levels of Error Correction Code (ECC)
- Quick Search (100 times normal Read/Write speed)
- Random Read
- N-Group Write Option
- Dual Partition Option
- SCSI Disconnection/Arbitration

Precautions

Installation

Avoid placing the drive in a location subject to:

- high humidity
- high temperature
- mechanical shock and vibration
- direct sunlight

Operation

- * Do not move the drive while it is operating. Doing so may cause a malfunction to occur.
- * Avoid exposing the drive to sudden changes from low to high in temperature. This may cause water condensation to collect inside the drive. If the ambient temperature should suddenly rise while the drive is turned on, wait at least one hour before turning on the drive. If you attempt to operate the drive immediately after a sudden increase in temperature, a malfunction may occur.
- * Do not turn off the drive while the tape is in the drive.

Transportation

- * Keep the original packing materials to facilitate transportation of the drive.
- * Always remove the tape before moving the drive. After removing the drive from the computer, repack the drive into its original packaging.

Installation

SCSI Connection/Setting the SCSI ID/Option Switches

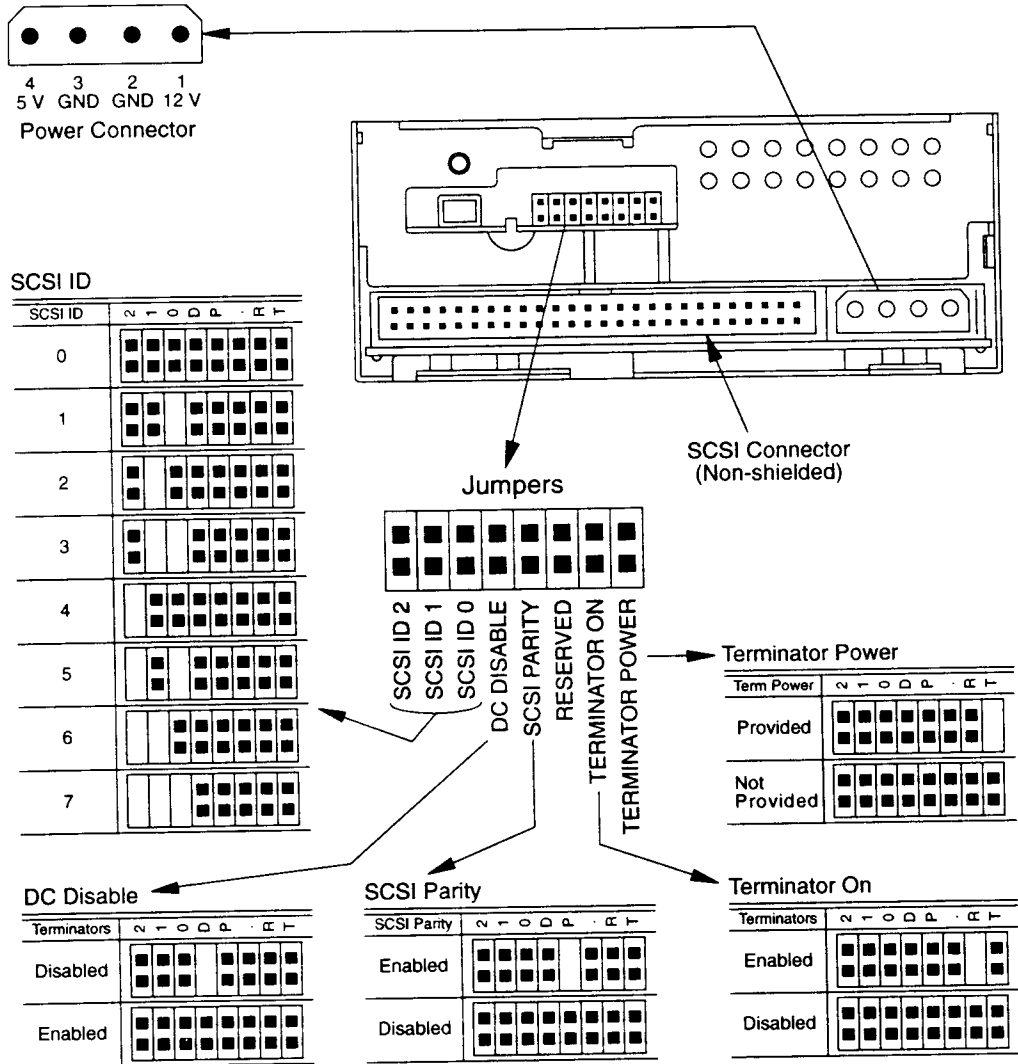

Note : □ = CLOSED Jumper installed
 ■ = OPEN Jumper not installed

Mounting Holes for 3.5" Standard Height

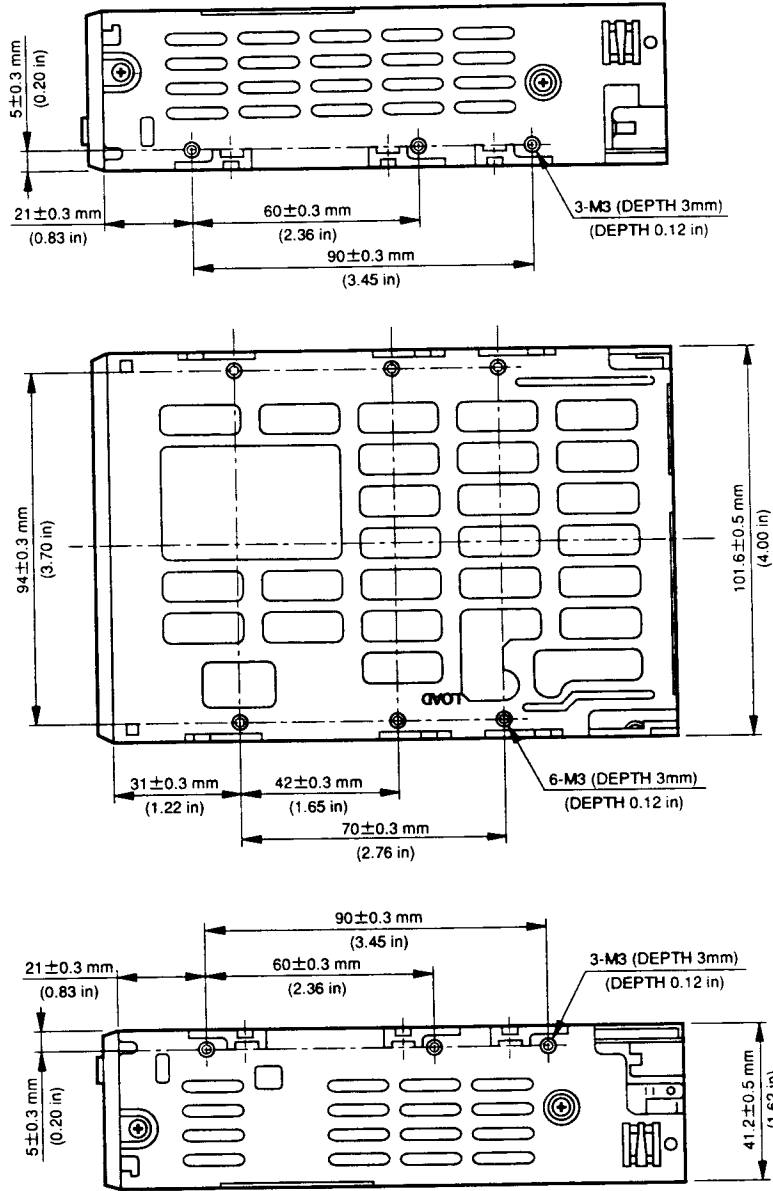

Mounting Holes for 5.25" Half Height

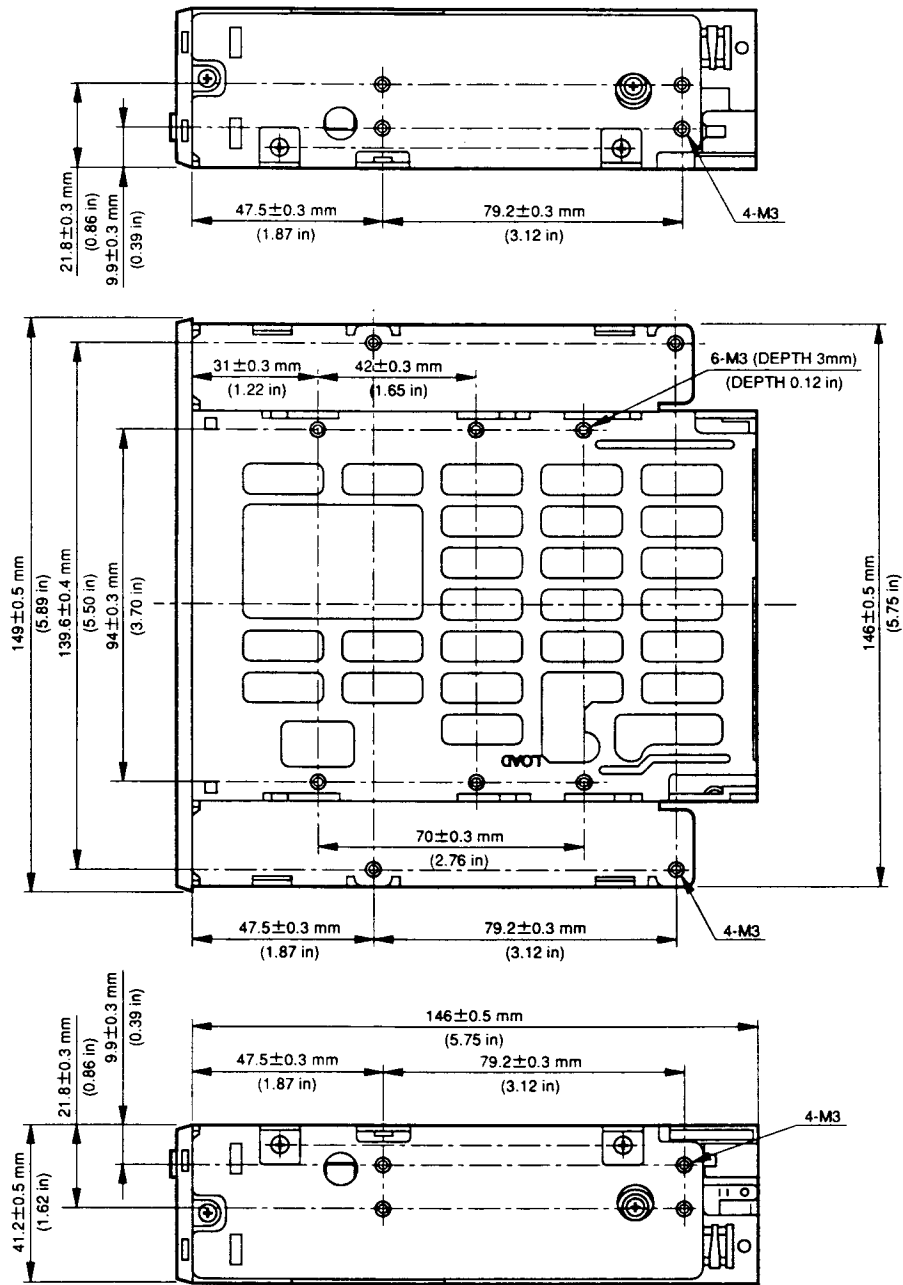

Orientation

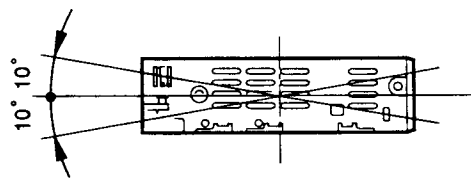
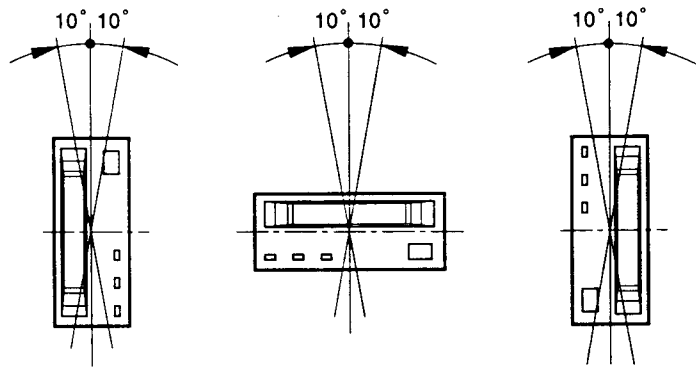

Operation

Location of 3 LEDs

There are three LED indicators (BUSY, TAPE and STATUS) and an EJECT button on the front panel of the unit.

Front Panel (for 3.5" Standard Height)

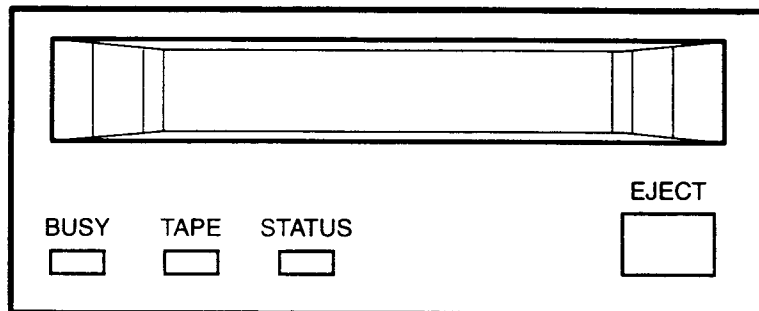

LED Indication for Drive Status

LED			State		
BUSY	TAPE	STATUS	Activity	Cartridge	Other
			None	None	None
			SCSI	None	None
			Drive	Loading/Unloading	None
			Drive	Loading/Unloading	Write Protected
			None	Loaded	None
			SCSI	Loaded	None
			SCSI/Drive	Loaded	None
Independent			*	Loaded	Write Protected
			None	Loaded	Cleaning Tape at EOM
Independent		Independent	*	Loaded	Error Rate Warning
	Independent	Independent	*	*	Humidity Warning
*	*		*	*	Cleaning Request
*	*		*	*	Drive Mechanism Failure
*	*		*	*	Drive Circuitry Failure
	*	*	*	*	Waiting for Reset
*		*	*	*	Waiting for Eject

* : Not defined.



3.5 sec on / 0.5 sec off



off



1 pulse (0.25 sec on)



on



2 pulses (0.25 sec on), 0.5 sec off



0.25 sec on / 0.25 sec off

Drive Operation

Loading A Tape

Insert a cassette into the slot on the front panel with the arrow on the cassette pointing towards the drive. As the cassette is inserted, the drive takes it and automatically loads it into drive mechanism.



Unloading A Tape

The cassette can be removed from the SDT-7000 either in response to a SCSI Unload Command, or by pressing the eject button. By pressing Eject button, the tape goes to BOM, the drive unthreads it, and ejects the cassette from the slot.

Write-protecting A Tape

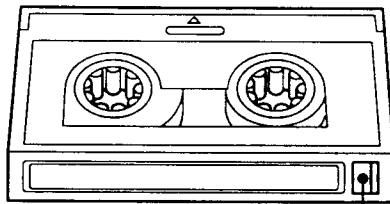
Cassettes can be write-protected by sliding the tab on the back of the cassette open. In this state, data can be read from the tape but not written onto it.



-  Using your fingernail, push the switch in the direction of the arrow to protect the tape from writing or accidental erasure.
-  Return the switch to its original position to re-enable writing.

Using A Cleaning Tape

The SDT-7000 has a built-in super head cleaner designed to last for the life of the drive. In addition, a cleaning tape should be used periodically to clean the entire tape path. The drive will automatically request that the user perform a cleaning operation. The need for a cleaning tape is determined by the drum rotating hours since the last cleaning was performed. The drive will request a cleaning operation every 24 hours of drum rotation.

Emergency Tape Removal Procedure

1. Remove the drive from the chassis or enclosure to allow access to the bottom and left side of the drive.
2. Remove the drive's top cover.
3. Locate the small opening in the bottom of the drive and insert the tip of a small screwdriver so that the Loading/Threading motor shaft can be rotated.
4. Rotate the motor shaft clockwise to bring the threading mechanism back to the initial position.
Caution: Excessive rotation beyond mechanism dead-end may cause damage to the drive mechanism.
5. Before continuing the manual eject procedure, tape slack must be removed in order to prevent tape damage.
Repeatedly press the ratchet mechanism located on the left side of the drive to tighten the tape.
6. After tape slack has been removed, continue to turn the motor shaft clockwise until the tape is lifted out of the drive mechanism and is ejected.
7. Return the drive to the service station for repair.

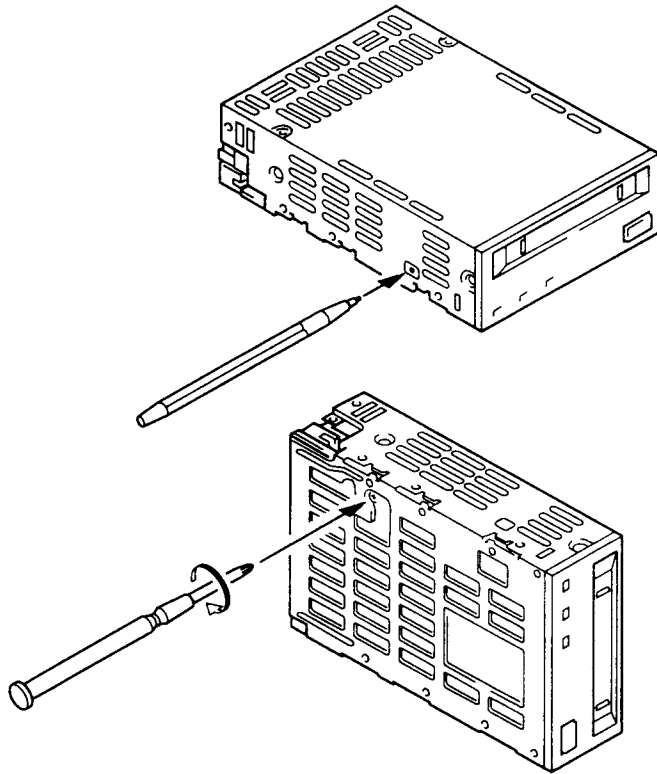

Interface Implementation

Supported SCSI Messages

Abort	Message Parity Error
Bus Device Reset	Message Reject
Command Complete	No Operation
Disconnect	Restore Pointers
Extended Message	Save Data Pointer
-Synchronous Data Transfer Request	
Identify (w/&w/o Disconnect)	
Initiator Detected Error	

Supported SCSI Commands

Erase	Receive Diagnostic Results
Inquiry	Release Unit
Load/Unload	Request Block Address
Locate	Request Sense
Log Select	Reserve Unit
Log Sense	Rewind
Mode Select (6)	Seek Block
Mode Sense (6)	Send Diagnostic
Prevent Allow Medium Removal	Space
Read	Test Unit Ready
Read Block Limits	Verify
Read Buffer	Write
Read Position	Write Buffer
	Write Filemarks

Specification

Product Specifications

Dimensions

	3.5" Standard Height	5.25" Half Height
Height	41.2 mm (1.62 in)	41.2 mm (1.62 in)
Width	101.6 mm (4.0 in)	146.0 mm (5.75 in)
Depth	146.0 mm (5.75 in)	146.0 mm (5.75 in)

Acoustic Noise (A) curve weight

Streaming Write/Read	35 db (A)
Insert/Eject	60 db (A)

Note : The sound-meter on (A) scale is located 1m in front of the center of the drive front panel.

Altitude

Operating	0 to 7000 feet
-----------	----------------

Shock

Operating	No Data Loss Half Sine Performance 5 G Peak 3 ms 3 axes, 3 directions *Interval 10 seconds
Non-Operating	No Device Damage Half Sine 90 G Peak 3 ms (30 G Peak 11 ms) 3 axes, 3 directions *Interval 10 seconds

Vibration

Operating	Swept Sine 5 to 500 Hz *0.25 G Peak 1 Octave/min.
Non-Operating	Swept Sine 5 to 500 Hz *0.5 G Peak 1 Octave/min. 3 axes, 3 directions

Temperature and Humidity Range

Temperature

Operating	5 °C to 40 °C ($\Delta T < 10$ °C/h)
Non-Operating (mech)	- 40 °C to 70 °C ($\Delta T < 20$ °C/h)
Non-Operating (tape)	- 40 °C to 45 °C ($\Delta T < 20$ °C/h)

Humidity

Operating	20 to 80% RH, non-condensing Maximum wet bulb temperature = 26 °C
Non-Operating (mech)	5 to 95% RH ($\Delta RH < 30\%/h$)
Non-Operating (tape)	20 to 80% RH ($\Delta RH < 30\%/h$)

Power Requirements

Voltage	Max Ripple	Current	
		Typical	Maximum
5V +/- 5%	100 mVp-p	1.5 A	2 A
12 V +/- 10%	100 mVp-p	0.2 A	0.6 A

Suspended Particulate

Operating	Less than 150 microgram/m ³
-----------	--

EMI

Radiated	FTZ/FCC class B, VCCI-2 (Equivalent)
Conducted	FTZ/FCC class B, VCCI-2 (Equivalent)
ESD	Discharge Voltage < 15 kV: No operation failure < 20 kV: No drive damage

Air-cooling Requirement

Surrounding temperature	< 40 °C
-------------------------	---------

Clean air flow is recommended to minimize the possibility of data loss.

Third Party Support Contacts

Host Adapter Vendors		Phone Numbers
Adaptec		408-945-8600
ATTO		716-691-1999
Bus Logic		408-492-9090
DPT		407-830-5522
Future Domain		714-253-0400
Initio		408-988-1919
Qlogic		714-438-2200
Ultra Systems Inc.		714-367-8800

Operating Systems	Backup Software Vendors	Phone Numbers
DOS	Arcada	407-333-7500
	Cheyenne	516-484-5110
	Columbia Data Products	407-869-6700
	Corel	613-728-8200
	NovaStor	805-579-6700
	Palindrome	708-505-3300
	ST. Bernard Software	619-676-2277
	Sytron	508-898-0100
	Tapedisk	715-235-3388
Macintosh	Cheyenne	516-484-5110
	Corel	613-728-8200
	Dantz	510-253-3000
	NovaStor	805-579-6700
OS/2	Cheyenne	516-484-5110
	Corel	613-728-8200
	IBM	800-426-3333
	NovaStor	805-579-6700
	Sytron	508-898-0100
Windows	Arcada	407-333-7500
	Cheyenne	516-484-5110
	Corel	613-728-8200
	Creata	909-595-8811
	NovaStor	805-579-6700
	ST. Bernard Software	619-676-2277
	Sytron	508-898-0100
Windows NT	Arcada	407-333-7500
	Cheyenne	516-484-5110
	Creata	909-595-8811
	Microsoft	206-882-8080
	NovaStor	805-579-6700
	Avail Systems	303-444-4018
Windows NT Advanced Server	Microsoft	206-882-8080
Windows 95	NovaStor	805-579-6700
DEC Unix	Cheyenne	516-484-5110
	NovaStor	805-579-6700
	Software Moguls	612-933-8790
	Work Station Solutions	603-880-0080

Operating Systems	Backup Software Vendors	Phone Numbers
SUN Unix	Legato	415-812-6000
	NovaStor	818-707-9900
	Software Moguls	612-933-8790
	Sun Soft	310-348-8649
	Work Station Solutions	603-880-0080
Solaris Unix	Cheyenne	516-484-3150
	Legato	415-812-6000
	NovaStor	818-707-9900
	Software Moguls	612-933-8790
	Sun Soft	310-348-8649
SCO Unix	Work Station Solutions	603-880-0080
	Cheyenne	516-484-3150
	Legato	415-812-6000
	Software Moguls	612-933-8790
	Work Station Solutions	603-880-0080
NCR Unix	NovaStor	818-707-9900
	Work Station Solutions	603-880-0080
HP Unix	Cheyenne	516-484-3150
	NovaStor	818-707-9900
	Work Station Solutions	603-880-0080
AIX Unix	Cheyenne	516-484-3150
	Legato	415-812-6000
	NovaStor	818-707-9900
	Software Moguls	612-933-8790
	Work Station Solutions	603-880-0080
Interactive Unix	Sun Soft	310-348-8649
SGI Unix	Software Moguls	612-933-8790
	Work Station Solutions	603-880-0080
Novell UNIXware	Novell	801-429-5544
Novell NLM	Arcada	407-263-3500
	Avail Systems	303-444-4018
	Cheyenne	516-484-3150
	Columbia Data Products	407-682-0265
	Creata	909-595-8811
	Legato	415-812-6000
	NovaStor	818-707-9900
	Novell	801-429-5544
	Palindrome	708-505-3300
	Performance Tech	210-979-2110
	ST. Bernard Software	619-676-2277
	Symantec	310-449-4156
	Sytron	508-898-0100
	Banyan	Performance Tech
Lantastic	NovaStor	818-707-9900
Amiga	Moonlighter	407-384-9484
RS6000	Legato	415-812-6000
	NovaStor	818-707-9900
	Software Moguls	612-933-8790

Sony Contacts

For further information, please contact:

Sony Electronics Inc., Technical Support

3300 Zanker Road San Jose, CA95134, 1940. USA
TEL: (1) 800-352-7669 FAX: (1) 800-883-7669 TELEX: 171331

Sony Corporation, Gigabyte Storage Products

Computer Peripheral Division

4-10-18 Takanawa, Minato-ku, Tokyo 108 Japan
Tel: (03) 5448-2289 FAX: (03) 5448-7902 TELEX: J22262

Sony of Canada Ltd., Computer and Personal Information Division

405 Gordon Baker Road, Willowdale, Ontario, M2H 2B6, Canada
TEL: (416) 499-1414 FAX: (416) 499-8541

Sony Computer Peripherals Components Europe

A Division of Sony Deutschland GmbH

Landsberger Strasse 428 D-81241 München, Germany
Compuserve 100634, 1752 FAX: (089) 82916-470

Sony International (Singapore) Ltd.

Asia Components Marketing Company

10 Hoo Chiang Road #21-00 Kepple Towers, Singapore 089315
TEL: (65) 329-1553 FAX: (65) 329-1590

Sony Electronics Devices (Hong Kong) Limited

25/F Tower II, The Gateway, 25 Canion Road, TST, Kowloon, Hong Kong
TEL: (852) 2956-0888 FAX: (852) 2956-4600

Sony Comércio e Indústria Ltda.

Rua Incêncio Tobias, 125-Terreço Parte, Parque Industrial Thomas Edson-Barra
Fundá, CEP01144-900, São Paulo, Brazil
PABX: (011) 826-1177 FAX: (011) 825-1542 TELEX: (011) 21677

Sony (Australia) Ltd., Computer Products Division

A.C.N. 001 215 354
33-39 Talavera Road (Box 377, Post Office), North Ryde, N.S.W. 2113, Australia
TEL: (02) 887-6667 FAX: (02) 805-1241 TELEX: 24254

This document contains proprietary information which is protected by copyright.
All rights reserved. No part of this document may be photocopied, reproduced or translated to another language without prior written consent of Sony.
The information contained in this document is subject to change without notice.

SONY MAKES NO WARRANTY OF ANY KIND WITH REGARD TO THIS DOCUMENT.

Sony shall not be liable for error contained herein, indirect, special, incidental or consequential damages in connection with the furnishing, performance or use of this document.

© Copyright 1996 Sony Corporation
Printed in JAPAN

3-856-287-01