

NASA CR-166697



(NASA-CR-166697) REFSAT/GIS BREADBOARD:
TEST TERMINAL HARDWARE DESIGN REPORT
(Systematics General Corp.) 43 p
HC A03/AF A01

#81-28314

CSCL 173

Unclass

G3/32 31110



Systematics General Corporation

2922 Telestar Court

Falls Church, Virginia 22042

REFSAT/GPS BREADBOARD - TEST TERMINAL
HARDWARE DESIGN REPORT

November 1980

Prepared for

National Aeronautics and Space Administration
Goddard Space Flight Center
Earth Observation Systems Division
User Terminal & Location Systems Branch
Greenbelt, Maryland 20771

Prepared Under NASA/GSFC Contract NAS5-26039

ABSTRACT

This report describes the hardware design and the test plan needed to verify the REFSAT concept.

At a given moment, all users of the NAVSTAR Global Positioning System (GPS) located within a rather large geographical area are required to perform a number of identical, common operations in order to accomplish a navigation "fix" (additional "location-dependent" operations are also required).

Under the REFSAT concept, the common operations are performed at a central location and results broadcast via a geostationary reference satellite (REFSAT). This concept allows a considerable reduction in the cost and complexity of individual civil user terminals.

The hardware design of a REFSAT/GPS receiver terminal and the REFSAT transmitter simulator is described.

Since six of the Phase I NAVSTAR GPS satellites are now operational a demonstration test plan utilizing the one-to-two hour per day viewing window is also described.

Equipment check-out preliminary test results are presented.

TABLE OF CONTENTS

<u>SECTION</u>	<u>PAGE</u>
1.0 REFSAT/GPS BREADBOARD-TEST TERMINAL HARWARE DESIGN.....	1
1.1 Introduction.....	1
1.2 System Description of Prototype REFSAT/GPS Receiver...	5
1.2.1 REFSAT/GPS Receiver Noise Budget.....	6
1.2.2 GPS and REFSAT Signal RF Link Computations.....	8
1.3 Circuit Description of Prototype REFSAT/GPS Receiver Terminal.....	10
1.3.1 REFSAT Signal Channel.....	13
1.3.2 GPS Signal Channel.....	13
1.3.3 Receiver Frequency Synthesizer.....	14
2.0 REFSAT TRANSMITTER SIMULATOR.....	16
3.0 REFSAT/GPS RECEIVING TERMINAL TEST PLAN.....	18
3.1 Typical GPS Satellite Constellation Viewing Window....	20
3.2 GPS REFSAT Test Block Diagram.....	27
3.2.1 REFSAT Word Generator Description.....	29
3.2.2 Logging Mode Data Handling Description.....	31
3.2.3 Use of Computer to Aid Time Word Generator Synchronization.....	32
3.3 Test Procedure.....	33
4.0 CHECKOUT TEST PERFORMANCE.....	34
4.1 RF Amplification and Frequency Translation Tests.....	34
4.2 REFSAT Signal Carrier Recovery.....	35
4.3 REFSAT Signal Data Demodulation.....	35
4.4 Doppler Correction.....	35
4.5 Correlation.....	35
4.6 Conversion of Analog Correlation Data to Digital Form.....	36

LIST OF FIGURES

<u>FIGURE</u>	<u>PAGE</u>
1. The REFSAT Concept	2
2. Prototype REFSAT/GPS Receiver and Simulated REFSAT.....	4
3. REFSAT/GPS Receiver Terminal	11
4. Receiving Antenna Elevation Pattern	12
5. Receiver Frequency Synthesizer	15
6. REFSAT Transmitter Simulator Block Diagram	17
7. GPS Satellite Ground Tracks (20 degree elevation visibility contour shown around Washington, D.C.)	22
8. GPS Ground Tracks, 1600-2000 hrs GMT, 1 January 1979 (20 degree elevation visibility contour shown around Washington, D.C.)	22
9. GPS Satellite Elevation Angles at Washington, D.C.	23
10. Dilution-of-Precision (DOP) Values at Washington, D.C.	23
11. GPS Satellite Elevation Angles at Washington, D.C.	24
12. Dilution-of-Precision (DOP) Values at Washington, D.C.	24
13. GPS REFSAT Test Block Diagram.....	28
14. Microcomputer Interface to Test Equipment	30

LIST OF TABLES

<u>TABLE</u>	<u>PAGE</u>
1. Receiver Noise Budget	7
2. GPS Channel Link Computations (1575.42 MHz)	8
3. REFSAT Signal Channel Link Computations (1556.40 MHz)	9
4. NAVSTAR Phase I Orbit Data at First Ascending Node on 1 January 1979	21
5. GPS Satellite Test Window at Washington, D.C.	25
6. GPS Satellites In Orbit As Of June 1980.....	26

1.0 REFSAT/GPS BREADBOARD-TEST TERMINAL HARDWARE DESIGN

1.1 Introduction

This section describes the REFSAT/GPS receiver hardware design for an experimental prototype GPS REFSAT-Aided Receiver. The prototype receiver is to be used to verify the REFSAT concept, making use of the Clear/Acquisition, C/A, code signals from the Phase I GPS satellites to determine a user terminal's geographical location with an error not exceeding 50 meters (rms).

A REFSAT-aided receiver makes use of a reference signal generated by the REFSAT system to aid GPS signal acquisition and to reduce the complexity of user computations. The concept is illustrated in Figure 1 and compared with that of a conventional GPS receiver.

The REFSAT system would consist of an earth station and geosynchronous relay satellite serving a particular geographical area. A REFSAT Remote Control Station (RCS) would perform the following functions normally performed by individual conventional GPS receivers:

- Selects four visible GPS satellites having minimum horizontal-dilution-of-precision (HDOP);
- Acquires the four GPS satellite C/A signals and demodulates the 50 bps data channel to obtain GPS satellite ephemeris data; an option is to obtain ephemeris data by Land Line, or other means;
- Computes current GPS satellite position coordinates;
- Computes current GPS satellite Doppler coefficients.

In addition to GPS doppler coefficient data, the REFSAT RCS transmits a stable reference carrier frequency, offset from the GPS C/A signals, for rapid acquisition.

The REFSAT signal thus contains a stable reference carrier frequency, current GPS satellite position coordinates and doppler coefficient data which is transmitted to the geosynchronous REFSAT satellite for broadcast to GPS REFSAT Mobile Terminals (RMTs).

As shown in Figure 1, a REFSAT RMT performs the following functions:

- Acquires the REFSAT reference carrier frequency which is stable within ± 10 Hz as a reference frequency for GPS signal acquisition;
- Demodulates REFSAT doppler coefficient data and computes doppler corrections; acquires GPS signals;

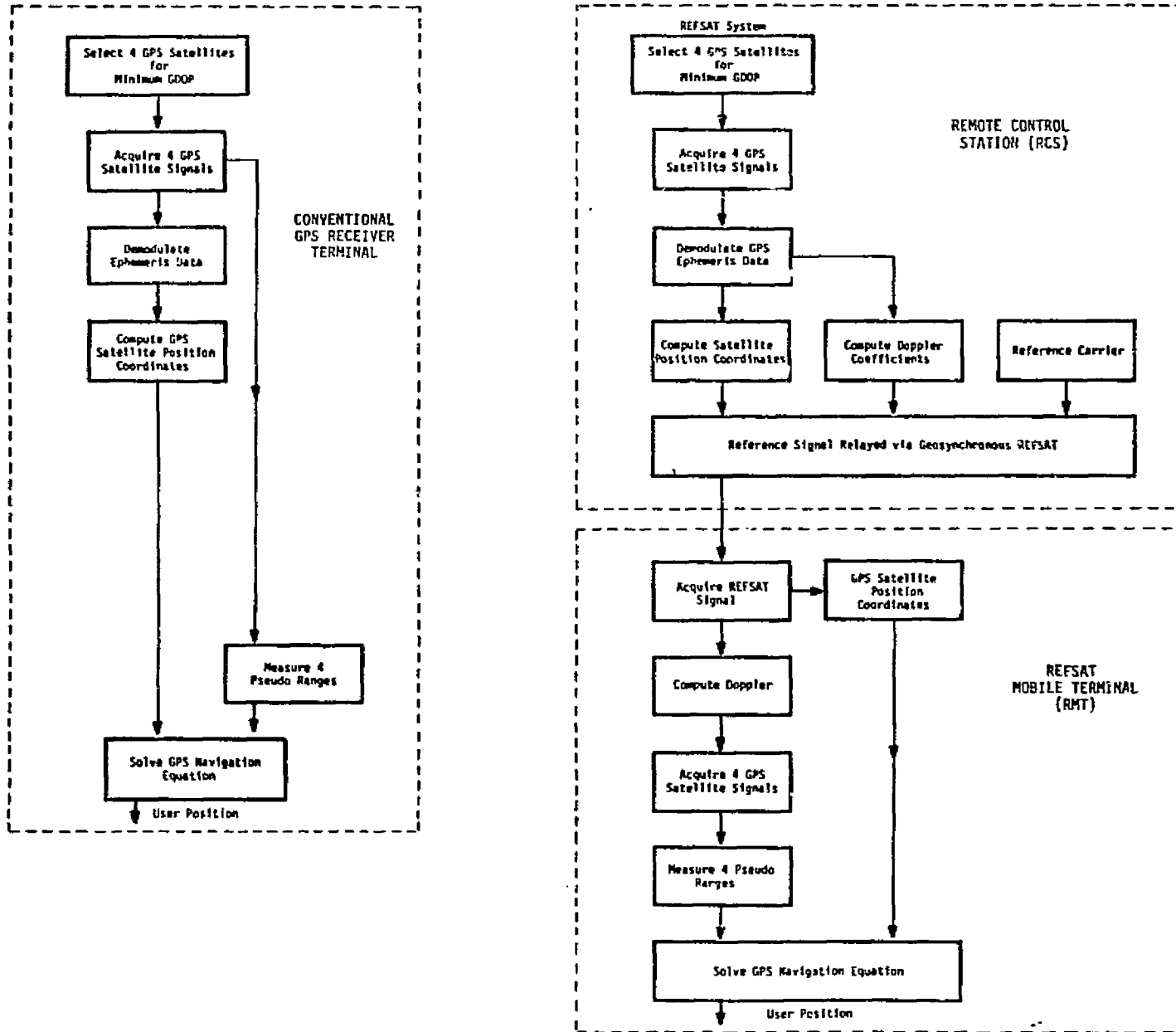

Figure 1. The REFSAT Concept.

- Demodulates current GPS satellite position coordinate data from the REFSAT signal;
- Makes pseudo-range measurements to four selected GPS satellites;
- Solves GPS navigation equation to determine user position; an option is to use a "report-back" transmitter to relay pseudo-range measurements back to the RCS for computation of user position.

For preliminary tests with Phase 1 GPS satellites, several of the functions shown in Figure 1 will be simulated or performed off-line as follows:

- Since the ATS-6 satellite is not available to test the REFSAT concept, a low-power (in the order of -120 dBW e.i.r.p.*) transmitter radiating within a few feet of the REFSAT-aided receiver's antenna will be used as a simulated REFSAT;
- Since current GPS satellite ephemeris data is not available either in advance or in real time**, the REFSAT reference signal used for experimental prototype testing will contain dummy GPS satellite position coordinate data messages. Measured pseudo-range values output from the receiver will be recorded for later off-line solution of the GPS navigation equation (when copies of the daily GPS upload data containing the required ephemeris data have been received by mail from Vandenberg AFB).

Figure 2 illustrates the prototype REFSAT/GPS receiver and the REFSAT simulation that will be used for preliminary tests.

The remainder of this document is contained in four sections:

- REFSAT/GPS Breadboard-Test Terminal Hardware Design
- REFSAT Transmitter Simulator Hardware Design
- REFSAT/GPS Receiver Terminal Test Plan
- Checkout Test Performance

* Effective Isotropic Radiated Power

** The REFSAT-aided receiver is, by design, incapable of directly demodulating the GPS navigation message (50 bps data).

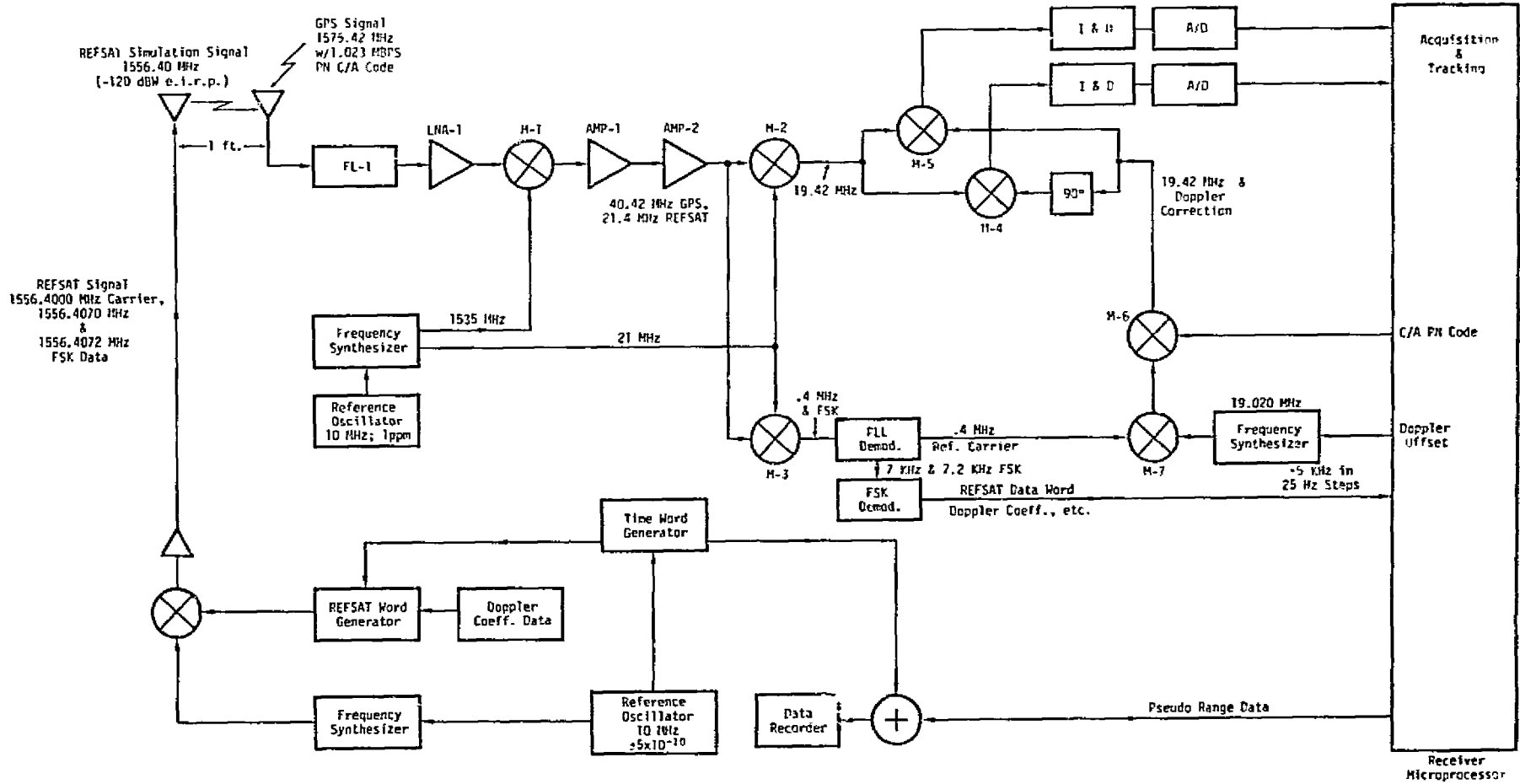

Figure 2. Prototype REFSAT/GPS Receiver and Simulated REFSAT.

1.2 System Description of Prototype REFSAT/GPS Receiver

This section describes the functional block diagram (Figure 2) for Prototype REFSAT/GPS Receiver to be used to verify the REFSAT concept. The following sections contain circuit descriptions of the receiver. The simulated REFSAT, also shown on Figure 2 is described in a later section.

The receiver processes:

- Signals from four GPS satellites:

1575.42 MHz \pm 4 kHz maximum doppler, containing 1.023 MHz C/A code (unique for each satellite)

- REFSAT reference signal containing:

a stable reference carrier frequency (\pm 5 parts 10^{10}) at 1556.40 MHz and,

the REFSAT data word stream (128 bps FSK, 1556.4070 MHz and 1556.4072 MHz).

The received signals are separated from other incident signals by a 30 MHz wide bandpass filter (FL-1) before preamplification. The receiver reference oscillator (10 MHz \pm 1 part in 10^6) and frequency synthesizer provide the necessary receiver local oscillator signals at 1535 MHz and 21.0 MHz.

Following the first mixer (M-1), the GPS and REFSAT signals are separated into two channels. The resultant 1st IF frequencies are 40.42 MHz \pm 4 kHz maximum expected doppler shift for the GPS channel and 21.4 MHz for the REFSAT channel. The following mixers in each chain share a common 21 MHz local oscillator frequency, resulting in 2nd IF frequencies of 19.42 MHz \pm 4 kHz for the GPS channel and 0.40 MHz for the REFSAT channel.

The REFSAT signal is applied to a PLL demodulator to separate the 0.400 MHz reference carrier from the FSK data signal (7.0 and 7.2 kHz). The FSK data signal is passed through a demodulator and thence as a 128 bps serial bit stream to the receiver microprocessor.

The receiver microprocessor makes use of the doppler coefficient data from the REFSAT data stream along with an approximate knowledge of receiver position to compute doppler offset values for each of the four GPS satellite signals that must be acquired. These doppler offset values are applied to a frequency synthesizer to produce a 19.020 MHz local oscillator signal which may be shifted \pm 5 kHz in 25 Hz steps for doppler compensation. This "doppler compensation" signal is mixed with the recovered REFSAT reference (0.40 MHz) in M-7. The resultant 19.42 MHz signal is then modulated with the appropriate 1.023 Mbps C/A code in M-6 corresponding to a particular GPS satellite.

GPS signal correlation is then accomplished in M-4 and M-5 and associated circuits under control of the receiver microprocessor. For a particular GPS satellite, inputs to the correlation mixers M-4 and M-5 are:

- Four (or more) GPS signals whose center frequency is 19.42 MHz \pm 4 kHz, and containing a frequency error present in the receiver reference oscillator as much as 1535 Hz, and
- "Doppler correction" signal whose carrier frequency is 19.420 MHz + computed doppler correction, and containing the same frequency error present in the receiver reference oscillator.

Thus, frequency errors due to the receiver reference oscillator cancel. The effective frequency accuracy of the "doppler correction" signal is essentially that of the reference oscillator employed in the REFSAT transmitter simulator ($1556.4 \times 5 \times 10^{-10}$ MHz = 0.8 Hz), limited by the 25 Hz synthesizer resolution. As a result, GPS signal acquisition can be accomplished without a lengthy frequency search.*

Following GPS signal acquisition, the receiver microprocessor determines pseudo-range values to each of the four GPS satellites by measuring the time offset between the four C/A code epochs from each of four GPS satellites. This output data is recorded for later off-line analysis.

1.2.1 REFSAT/GPS Receiver Noise Budget

Table 1 shows receiver noise budget computations. Components from Figure 1 are listed, in order, from the antenna through the 1st IF amplifier along with the equivalent noise temperature of each referenced to the antenna terminals.

Since the present receiver design does not include an image filter preceding the 1st mixer, the additional "image" noise has also been computed. The addition of an image filter would reduce the equivalent system temperature from 1434 to 1017 Kelvin. The resultant 1.5 dB reduction does not justify the additional expense of such a filter.

Note that the noise budget given in Table 1 includes the effect of 30 feet of RG-214 transmission line between the antenna and the receiver. Should this transmission line be removed, or the 1st mixer, LNA-1, and the filter FL-1 be remotely located at the antenna, the equivalent

* The four required GPS signals are acquired, and then sampled, sequentially.

TABLE 1
RECEIVER NOISE BUDGET

Component	Noise Factor	Loss Factor	Computation	Noise Temperature Referred to Antenna
Antenna	-	-		170 K
30' RG-214 (3 dB loss)	-	2.00	$290(2.00-1)$	= 290 K
Filter, FL-1 (0.9 dB loss)	-	1.23	$290(1.23-1) \times 2.00$	= 133 K
LNA-1 (30 dB gain, 2 dB NF)	1.58	1/1000	$290(1.58-1) \times 1.23 \times 2.00$	= 414 K
Mixer, M-1 (6 dB loss, 7 dB NF)	5.01	3.98	$290(5.01-1) \times (1/1000) \times 1.23 \times 2.00$	= 3 K
Amp-1 (28 dB gain, 5.2 dB NF)	3.31	1/631	$290(3.31-1) \times 3.98 \times (1/1000) \times 1.23 \times 2.00$	= 7 K
				<u>1017 K</u>
Since no image filter is used:			Noise at image frequency from LNA-1	414 K
			Noise at image frequency from M-1	<u>3 K</u>
			Equivalent system noise temperature	1434 K

7

receiver noise temperature would be reduced to 653 K. Use of an image filter could reduce this value to 445 K.

1.2.2 GPS and REFSAT Signal RF Link Computations

GPS signal RF link computations are given in Table 2. The GPS signal power at the receiving antenna output is expected to be -158.5 dBW. For the 1434 K receiver noise temperature shown on Table 1, the resulting GPS carrier-to-noise density ratio is expected to be 38.5 dB-Hz for a 5.5 dB C/N in the nominal 2 kHz post correlation bandwidth. This value may be increased to 41.9 dB-Hz for a 8.9 dB C/N ratio should the effect of the antenna transmission line be eliminated.

REFSAT signal link computations are given on Table 3. The REFSAT carrier signal power at the receiving antenna output is expected to be -146 dBW. For the receiver noise temperature shown on Table 1, the resulting REFSAT carrier-to-noise density is expected to be 51.0 dB-Hz, corresponding to an E_b/N_0 value of 20.0 dB.

TABLE 2
GPS CHANNEL LINK COMPUTATIONS (1575.42 MHz)

Radiated Power (satellite)	13.1 dBW
Transmitting Antenna Gain	12.0 dBi
Free Space Loss	-184.6 dB
Atmospheric Loss	-1.0 dB
Polarization Loss	-1.0 dB
Receiving Antenna Gain	3.0 dBi
Resultant power at receiving antenna output	-158.5 dBW
Equivalent receiving system noise temperature (1434 K from Table 1)	31.6 dBK
Boltzmann's constant (J/K)	-228.6 dB(J/K)
Resultant carrier-to-noise density ratio, C/N_0	38.5 dB-Hz
Required C/N_0 for Specified Performance	35.2 dB-Hz
Excess Margin	3.3 dB

TABLE 3

REFSAT SIGNAL CHANNEL LINK COMPUTATIONS (1556.40 MHz)

Equivalent Isotropic Radiated Power	-120.0 dBW
Free Space Loss (1 foot)	-26.0 dB
Polarization Loss	-3.0 dB
Receiving Antenna Gain	3.0 dBi
<hr/>	
Resultant carrier power at receiving antenna output	-146.0 dBW
Equivalent receiving system noise (1434 K from Table 1)	31.6 dBK
Boltzmann's constant	-228.6 dB (J/K)
<hr/>	
Resultant carrier-to-noise density ratio	51.0 dB-Hz
Carrier-to-FSK sideband ratio	-10.0 dB
<hr/>	
Resultant data signal-to-noise density ratio, C/N_0	41.0 dB-Hz
Data rate (128 b/s)	21.0 dB
<hr/>	
Resultant E_b/N_0 ratio	20.0 dB
Estimated bit error rate	less than 10^{-9}

1.3 Circuit Description of Prototype REFSAT/GPS Receiver Terminal

This section describes a breadboard REFSAT/GPS Receiver Terminal shown in Figure 3.

The REFSAT/GPS Receiver uses a reference signal generated by the REFSAT system to aid GPS signal acquisition and to reduce the complexity of user computations.

Briefly, the dual-channel REFSAT-aided receiver performs the following functions:

- 1) Acquires the REFSAT reference signal containing:
 - a) A stable carrier frequency signal which serves as the receiver precision frequency reference.
 - b) GPS doppler coefficient data (128 bps FSK)
- 2) Utilizes the stable REFSAT carrier signal and doppler data for acquisition of 4 GPS satellite signals.

The dual-channel, L-band REFSAT-aided receiver shown in Figure 3 receives both the REFSAT reference signal (1556.400 MHz) and GPS NAVSTAR satellite emissions (1575.420 MHz C/A signal). The CHU Associates antenna provides essentially hemispherical coverage (3 dBi nominal gain for elevation angles of 30 degrees or greater above the horizon as shown on Figure 4).

For installations requiring a remote antenna location, the preselector filter, preamplifier, and first mixer may be placed close to the antenna, significantly reducing transmission cable losses.

Signals from the antenna are passed through a 4-pole cavity preselector filter (1565 MHz f_0 , 30 MHz BW at -3 dB points), reducing effects of out-of-band interference. A low-noise preamplifier (2 dB NF, 30 dB gain) is provided ahead of the first mixer, where a 1535 MHz local oscillator signal results in 1st IF frequencies of 40.42 MHz for GPS signals and 21.4 MHz for the REFSAT reference signal. Tandem post amplifiers (28 dB gain each) provide additional gain before the two channels are separated by a power divider and bandpass filters, FL-2 and FL-3.

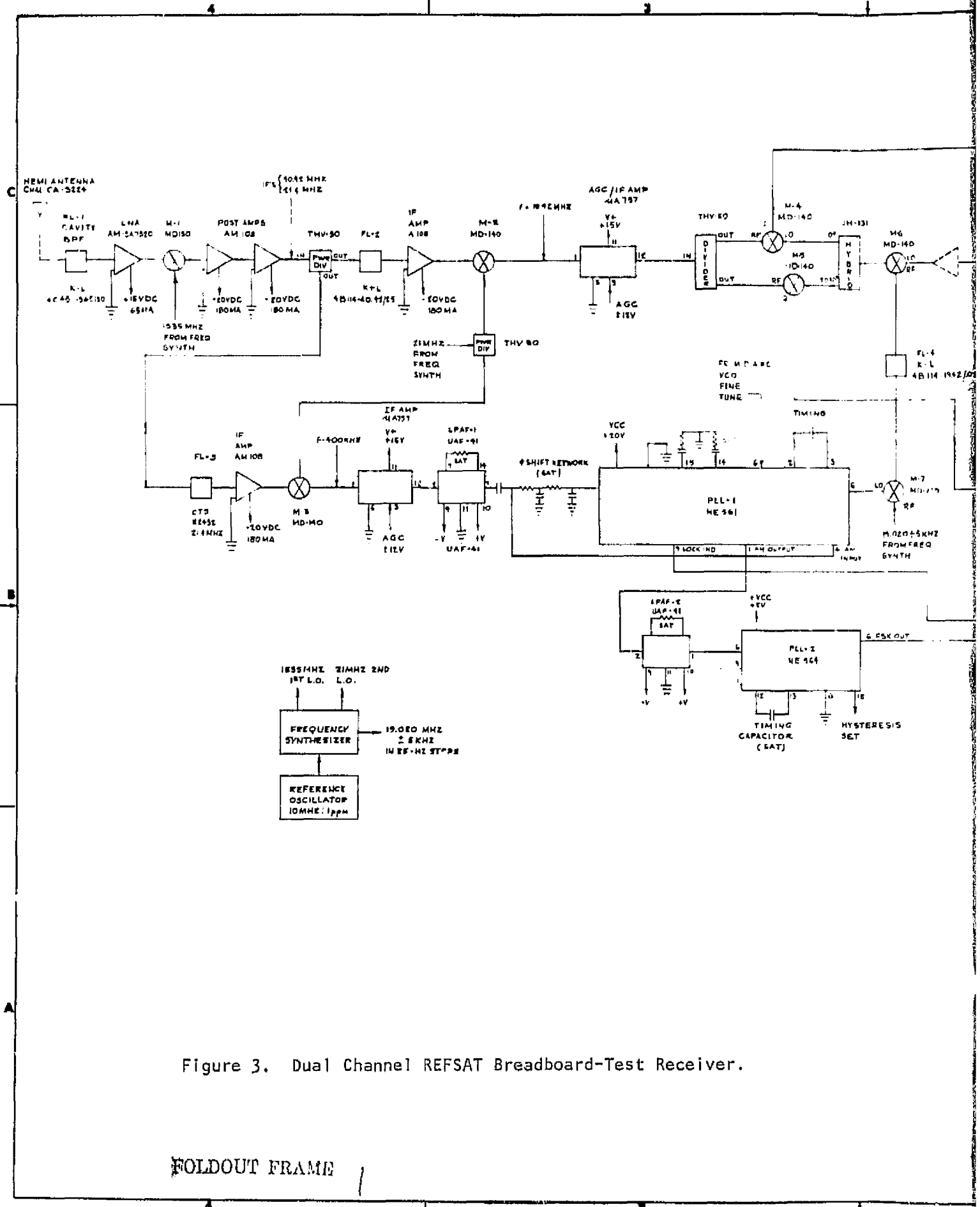
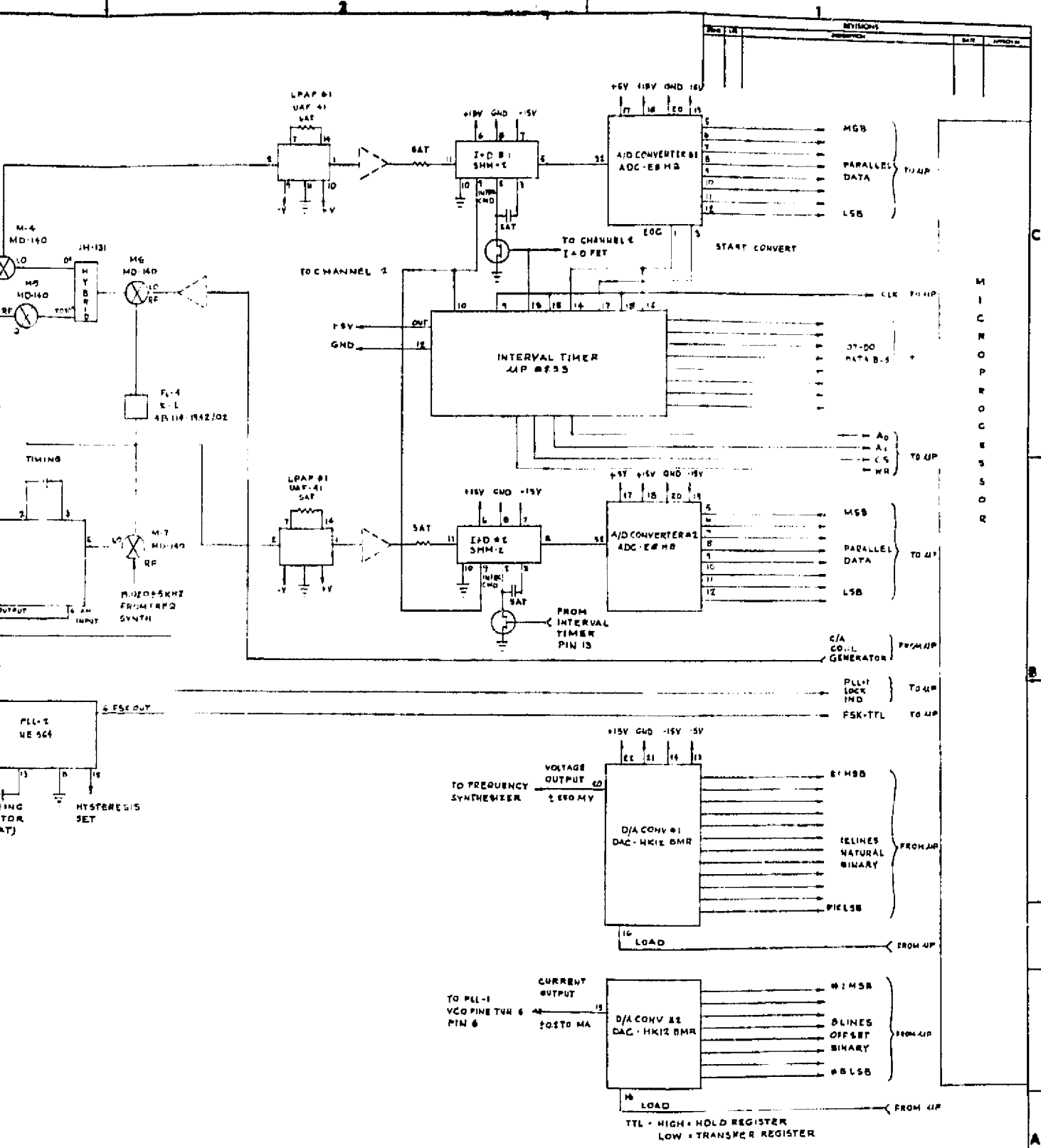

Figure 3. Dual Channel REFSAT Breadboard-Test Receiver.

FOLDOUT FRAME



PKT NO	QTY REQD	CODE POINT NO	PART OR IDENTIFYING NO	NOMENCLATURE OR DESCRIPTION	SPECIFICATION MATERIAL OR NOTE
PARTS LIST					
SYSTEMATIC GENERAL CORP DUAL CHANNEL REPEAT BREADBOARD-TEST RECEIVER				MICROPROCESSOR PARALLEL DATA LSB START CONVERT CLK PHIP D0-D5 A0 A1 CS WR MSB PARALLEL DATA LSB C/A COLL GENERATOR PLL1 LOCK IND FSK-TTL MSB 8 LINES NATURAL BINARY P1LSB MSB 8 LINES OFFSET BINARY #8LSB	
DO NOT SCALE THIS DRAWING				F	
APPLICATION				27-03H-1	

HOLDOUT FRAME
2

CHU ASSOCIATES

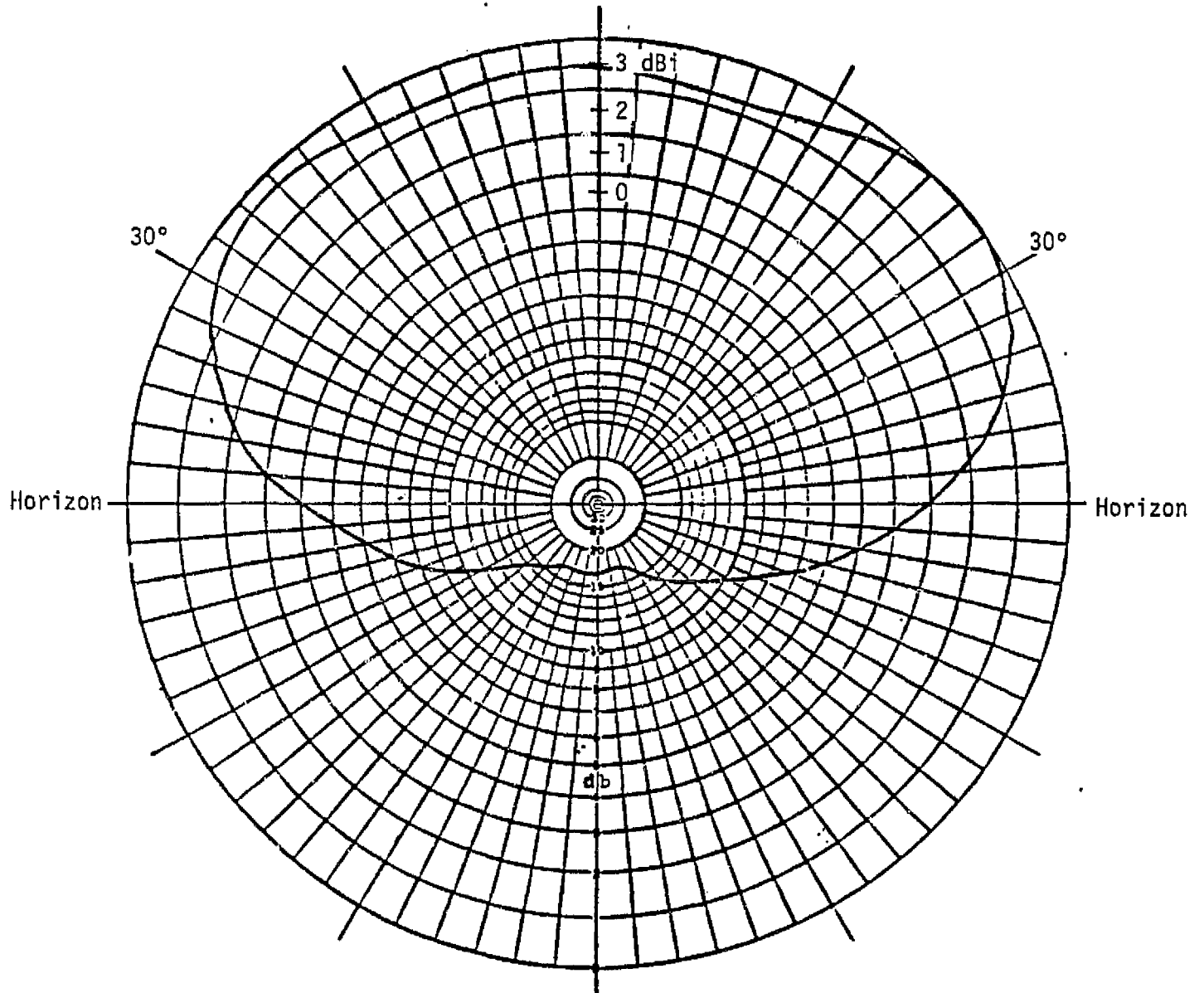

ANTENNA: <u>CA-3224 S/N 3</u>	PATTERN CUT ON:
FREQUENCY: <u>1575.4 MHZ</u>	AZIMUTH PLANE AT _____ ° ELEVATION
PLOTTED IN:	ZENITH PLANE AT <u>*</u> ° RELATIVE AZIMUTH
VOLTAGE <u>*</u> POWER _____	POLARIZATION: E _o _____ RHC <u>*</u>
DATE: <u>5-15-79</u>	E _o _____ LHC _____

Figure 4. Receiving Antenna Elevation Pattern.

1.3.1 REFSAT Signal Channel

After 1st IF post amplification, the REFSAT signal is separated from the GPS signals by bandpass filtering (21.4 MHz f_o , 30 kHz BW crystal filter FL-3). After further amplification, the REFSAT signal is converted to a 2nd IF of 400 kHz using balanced mixer M-3 and a 21 MHz LO signal. The signal is further amplified and filtered before carrier recovery and demodulation in the phase-locked loop, PLL-1. At this point, the REFSAT signal consists of a carrier at 400 kHz and data contained in two FSK side tones at 407.0 kHz and 407.2 kHz. The signal is split into two paths (in-phase and quadrature) to provide the needed inputs to the phase-locked loop demodulator, PLL-1.

The AM output of PLL-1 contains REFSAT data in the form of FSK tones at 7.0 kHz and 7.2 kHz. This signal is filtered and applied to PLL-2 for demodulation appearing as a standard TTL level serial bit stream at "FSK out" from PLL-2. The bit stream is supplied as an output to the microprocessor for GPS doppler coefficient data.

The recovered REFSAT carrier appears at pin 5 of PLL-1 and is used as the stable frequency reference needed for GPS signal acquisition. Note that at the antenna, the REFSAT carrier frequency is precisely 19.02 MHz below the GPS satellite carrier frequency (neglecting doppler). Since both the REFSAT and GPS signal channels share common LO signals from the receiver's master oscillator, this precise frequency difference is maintained independent of instabilities associated with the receiver master oscillator.

The 400 kHz recovered REFSAT carrier at pin 5 of PLL-1 is applied to mixer M-7 along with a digitally-controlled doppler offset signal from the frequency synthesizer. The digitally-controlled signal has a center frequency of 19.020 MHz and may be varied ± 5 kHz in 25 Hz steps by the microprocessor for doppler compensation. The output of mixer M-7 (19.420 MHz) is identical in frequency to that of GPS signal channel 2nd IF, neglecting doppler. This output is filtered in FL-4 (19.420 MHz f_o , 390 kHz BW) to reduce unwanted mixing components. This reference carrier is modulated in mixer M-6 with a replica of the GPS C/A code generated by the microprocessor and phase shifted in the hybrid to produce in-phase "I" and quadrature "Q" channel reference signals for C/A code correlation.

1.3.2 GPS Signal Channel

Returning to the 1st IF post amplifiers, the GPS signals are separated from the REFSAT signal by bandpass filtering (6% BW FL-2). After amplification (28 dB), the GPS channel is converted to a 19.42 MHz 2nd IF in mixer M-2 (sharing a 21 MHz local oscillator signal with the REFSAT channel).

This 2nd IF signal is then passed through an AGC amplifier to produce constant amplitude signals for code correlation. The output of the AGC amplifier is divided into two channels for correlation with the two quadrature reference signals derived from the REFSAT channel (mixers M-4 and M-5). The resultant I and Q channels are then processed identically through 2 kHz BW active filters, integrate-and-dump circuits, and fast A/D convertors (4 μ s). The timing for the integrate-and-dump and A/D circuits is synchronized and controlled from the microprocessor via the 8253 programmable interval timer at a 1-millisecond (ms) rate. The integrate and start-conversion commands are triggered by programmed delays in counters within the 8253. The end-of-conversion pulse from the I channel ADC-E8HB triggers the 8253 to reset the integration-and-dump circuits, setting the code loop to integrate over another code word for sequential correlation with 4 GPS satellite signals.

1.3.3 Receiver Frequency Synthesizer

The receiver frequency synthesizer shown on Figure 5 generates three local oscillator signals:

- 1st LO, 1535.00 MHz
- 2nd LO, 21.00 MHz
- 3rd LO and doppler compensation, 19.020 MHz \pm 5 kHz in 25 Hz steps.

All signals are derived from the receiver master oscillator (10 MHz X0, 1 ppm) using digital dividers, phase-locked multipliers, and balanced mixers. The L-band 1st LO signal makes use of a step-recovery diode (SRD).

Doppler compensation is provided by varying the frequency of a 20 kHz VCO \pm 5 kHz in 25 Hz steps upon command of the μ processor via the D/A converter shown on Figure 5.

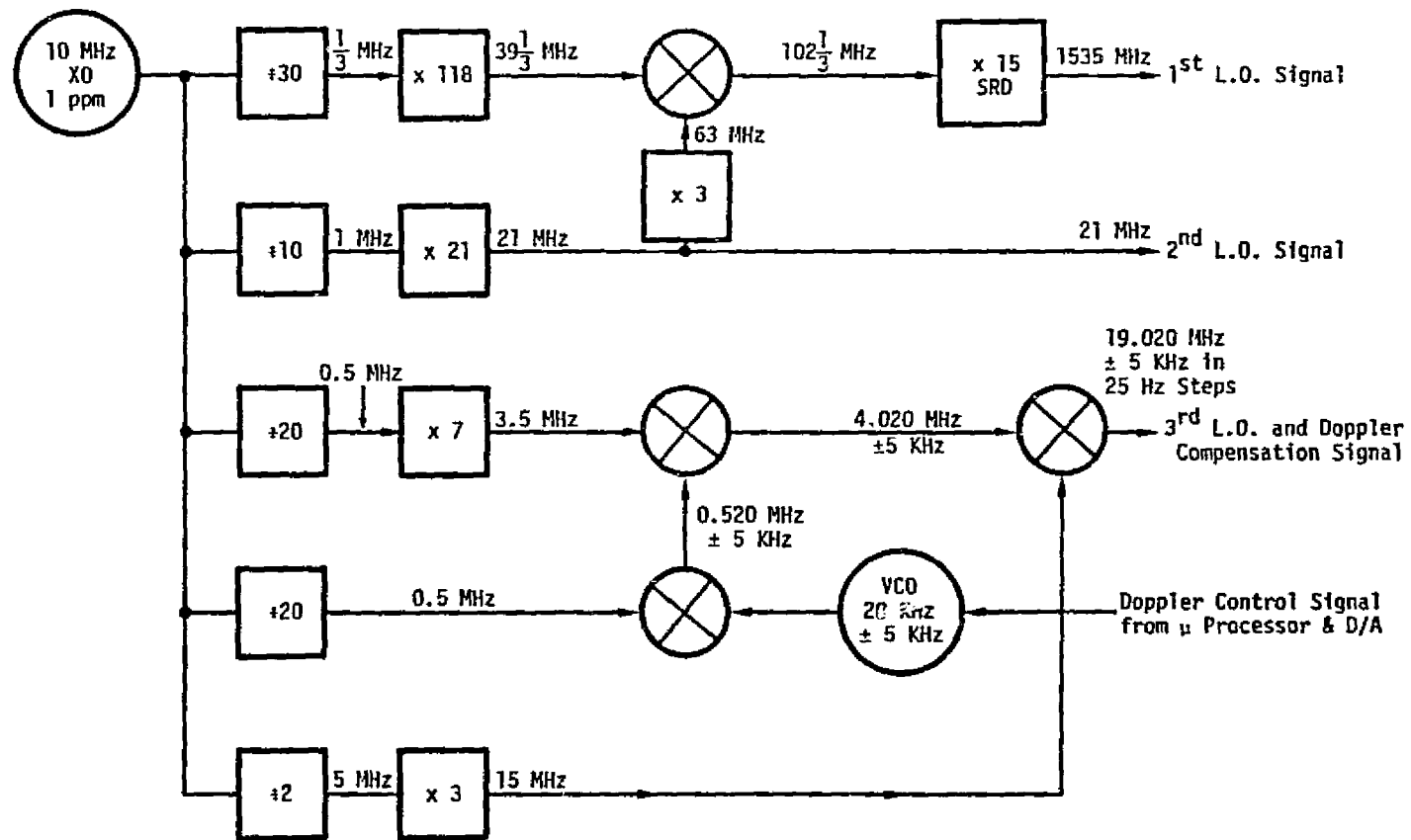

Figure 5. Receiver Frequency Synthesizer.

2.0 REFSAT TRANSMITTER SIMULATOR

The REFSAT/GPS Receiver makes use of the REFSAT reference signal to aid acquisition of GPS satellite emissions and to reduce computations at the user receiver. The REFSAT reference signal consists of:

- a) a stable carrier at a frequency of 19.02 MHz below that of GPS satellite emissions (1556.40 MHz for REFSAT) and,
- b) a 128 bps data stream (FSK, 1556.4070 MHz and 1556.4072 MHz) containing GPS doppler coefficient and other data.

It was originally planned to transmit the REFSAT reference signal through the ATS-6 satellite. Since ATS-6 is no longer available, it has been necessary to provide a separate transmitter to simulate the REFSAT transmission. This section provides a more detailed description of the circuit shown in Figure 2 to perform this function.

A block diagram of the REFSAT transmitter simulator is shown on Figure 6. A temperature controlled crystal oscillator (TCXO), stable to 5 parts in 10^{10} , is the reference from which the REFSAT reference carrier is derived in order to achieve the required frequency stability (± 10 Hz).

The serial REFSAT data stream (128 bps) modulates a voltage controlled oscillator (VCO), producing FSK sidetone signals at 7.0 and 7.2 kHz. The FSK sidetones and a 455 kHz carrier signal, derived from the 10 MHz master oscillator, are applied to an AM modulator. A bandpass filter rejects the lower sideband, yielding:

- A reference carrier at 455 kHz and,
- FSK sidetones at 462.0 and 462.2 kHz. (FSK sidetones are 10 dB below the reference carrier.)

The composite REFSAT signal is then translated to 21.4 MHz, 121.4 MHz, and finally to 1556.4 MHz (carrier frequency) for transmission.

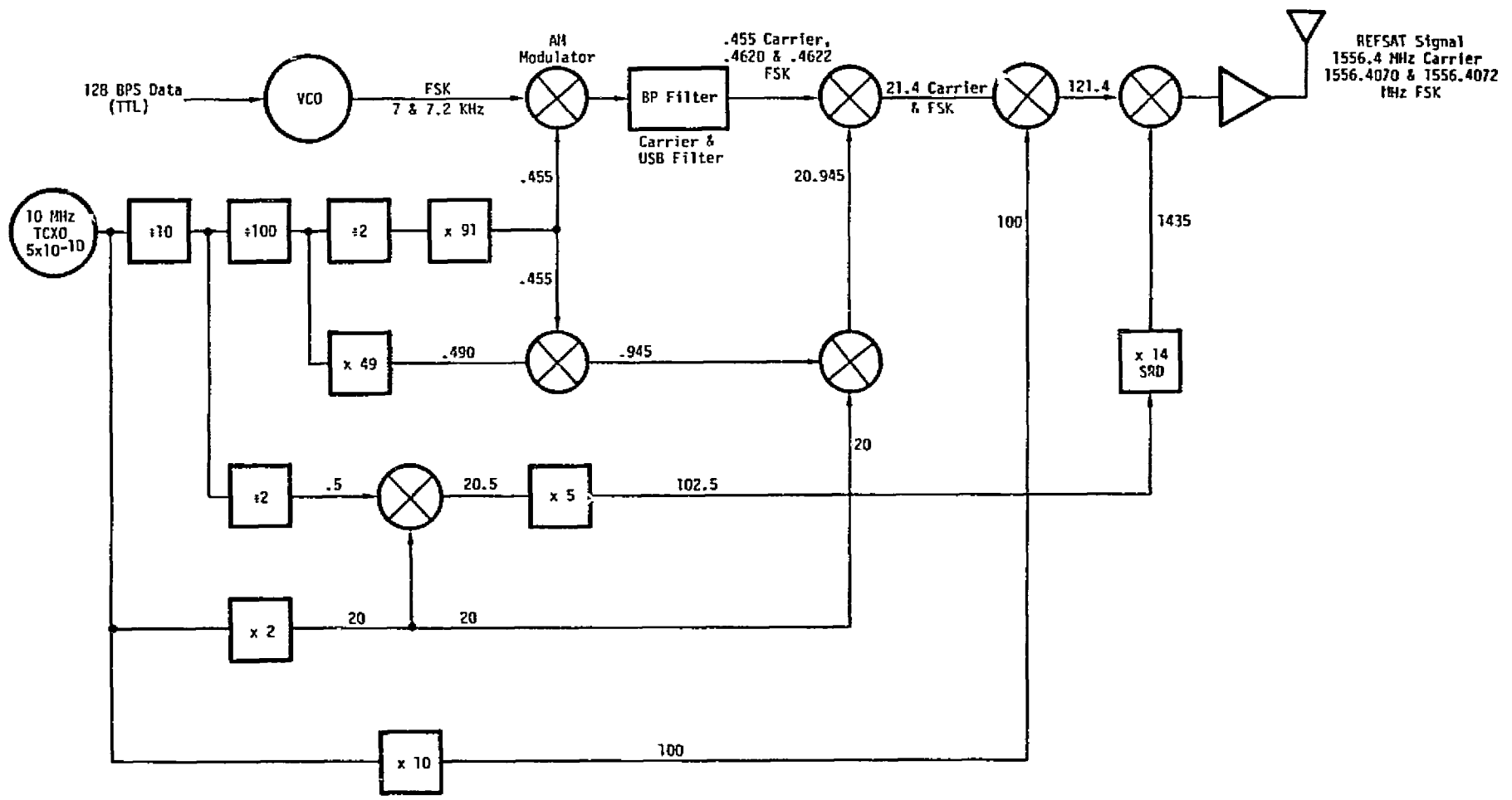

NOTE: Frequencies shown in MHz

Figure 6. REFSAT Transmitter Simulator Block Diagram.

3.0 REFSAT/GPS RECEIVING TERMINAL TEST PLAN

This test plan defines the equipment connections and procedures necessary to perform laboratory and satellite proof-of-concept tests of the REFSAT/GPS system including as test objectives:

- Verification of the REFSAT concept,
- Measurement of the terminal's geographical location with an error of not more than 50 meters (rms) for signals (C/A code) from the Phase I GPS satellites.

As shown on Figure 1 (Section I of this document), the REFSAT-aided user receiver:

- Acquires the REFSAT reference carrier (which serves as a stable receiver reference for GPS signal acquisition),
 - Demodulates current doppler coefficient data and computes doppler corrections for rapid GPS signal acquisition,
 - Demodulates current GPS satellite position coordinate data for direct insertion into GPS navigation equation solution;
- Makes use of REFSAT carrier reference and computed doppler corrections to acquire selected GPS C/A signals;
- Measures pseudo-ranges to 4 selected GPS satellites;
- Solves GPS navigation equation to determine user position.

Since the ATS-6 satellite will not be available to test the REFSAT concept as originally planned, a low-power transmitter radiating in the immediate vicinity of the REFSAT-aided receiver's antenna will be used.

Since current GPS satellite ephemeris data is not readily available either in advance or in real time*, the REFSAT reference signal used for testing will contain dummy GPS satellite position coordinate data. Measured pseudo-range values from the receiver will be recorded for later off-line solution of the GPS navigation equation when copies of daily GPS upload data containing the required ephemeris data are available several days later from the Vandenberg Air Force Base.

* The REFSAT-aided receiver is, by design, incapable of demodulating the GPS navigation message.

The remainder of this section is devoted to detailed definitions of the GPS satellite constellation viewing 'window', the experimental test connections, and procedures for conducting the necessary tests and data reduction.

3.1 Typical GPS Satellite Constellation Viewing Window

NAVSTAR Phase I nominal orbit information for the 4 GPS satellites operational at the beginning of 1980 is listed on Table 4; (GPS satellite orbit positions 1, 2, 3, 4, 5, and 6 are currently occupied by operational satellites). The orbit parameters are referenced to midnight (0 hours) Greenwich Mean Time (GMT) on 1 January 1979. On that date, the ground track of NAVSTAR #5 occupying orbit position #1 would first cross the equator in the South-to-North direction at a longitude of 47.0 degrees at 4 hours and 44.5 minutes on the GMT time scale. Some 43,078 seconds later (about 11 hours 58 minutes) it will again cross the equator in the South-to-North direction, this time at a longitude of 227.0 degrees. The time of succeeding ascending node crossings will be 4 minutes, 3.4 seconds earlier each following day*.

Figure 7 shows the computed ground tracks for those 4 GPS orbit positions listed in Table 4. The 20 degree elevation visibility contour about the test site (Washington, D.C.) is also shown. A satellite whose ground track is North of the visibility contour will appear at an elevation of 20 degrees or greater when viewed from the test site.

Figure 8 shows those portions of the GPS ground tracks between 1600 and 2000 hours GMT (the GPS constellation viewing window from the test site). The direction of ground track travel is noted and each track is marked at 1 hour intervals.

Figure 9 shows a plot of the individual satellite elevation angles as viewed from the test site as a function of time of day. Figure 10 shows computed dilution-of-precision values. The types of dilution-of-precision values shown are geometric (GDOP), three dimensional position (PDOP), and two dimensional horizontal (HDOP). This data is repeated on an expanded scale on Figures 11 and 12. The viewing window when all 4 satellites are visible above the horizon at the test site extends from about 1600 to 1950 hours (1 January 1979 reference) daily. From Figure 12, the dilution-of-precision values reach a minimum of 4 to 6 within the test window, rising rapidly after 1800 hours. (For example, for a DOP of 5, error in computed user position are expected to be about 5 times the error in measured pseudo-range values.) The useable test window will therefore extend from about 1630 hours through 1830 hours daily (1 January 1979 reference).

Note that the GMT time scale values given on Figures 8 through 12 apply to 1 January 1979. The time, GMT' at which a particular event occurs at a later date is given in decimal hours by:

$$\text{GMT}' = [\text{GMT} - 0.0676 (\text{times the day of year after 1 January 1979})] \text{ modulo } 24 \quad (1)$$

* The nominal ground trace of each satellite is fixed and therefore repeats every 23 hours 55 minutes and 56.6 seconds. This departure from a 24 hr. period is primarily due to the differences between a solar and a sidereal day.

TABLE 4

NAVSTAR PHASE I ORBIT DATA
AT FIRST ASCENDING NODE ON 1 JANUARY 1979

NAVSTAR SATELLITE	GPS ORBIT POSITION	INCLINATION	FIRST ASCENDING NODE LONGITUDE	FIRST ASCENDING NODE TIME (GMT)	ECCENTRICITY	ARGUMENT OF PERIGEE	NODAL PERIOD
#	#	deg.	deg.			deg.	s
NAV 5	1	63.25	47.0	4h44m30s	0.0038	343	43,078.3
NAV 4	3	63	89.5	2h00m59s	0	--	43,078.3
NAV 6	5	63.18	332.0	1h54m07s	0.0048	97	43,078.3
NAV 3	6	63	353.0	0h27m15s	0	--	43,078.3

Note: Parameters above are nominal. Nodal period is controlled to ± 2 s and longitude of ascending node is controlled to ± 2 deg. Hence the time of an ascending node may vary ± 8 minutes.

(Above data from memo - J.E. Farr, P.S. Jorgensen, 8 August 1978; Modified June 1980 NAVSTAR SATELLITE #).

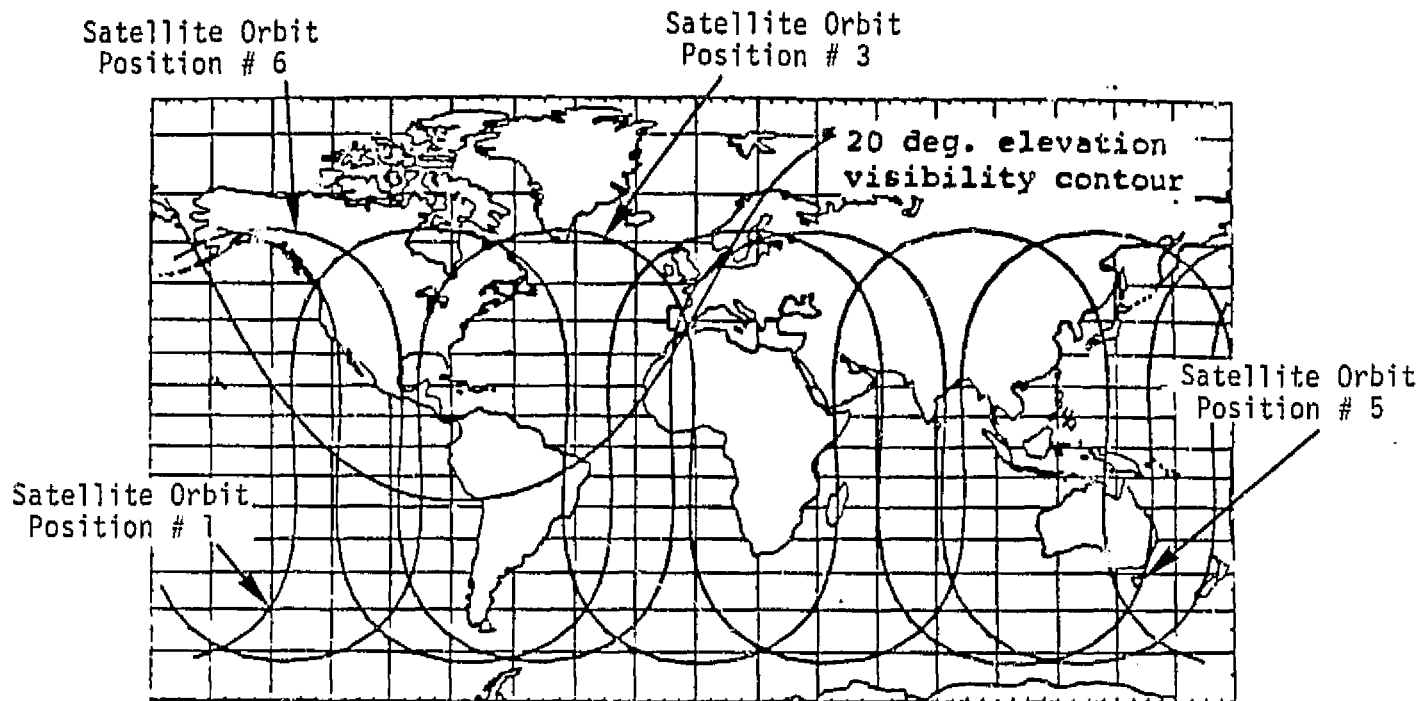

Figure 7. GPS Satellite Ground Tracks (20 deg. elevation visibility contour shown around Wash., D.C.)

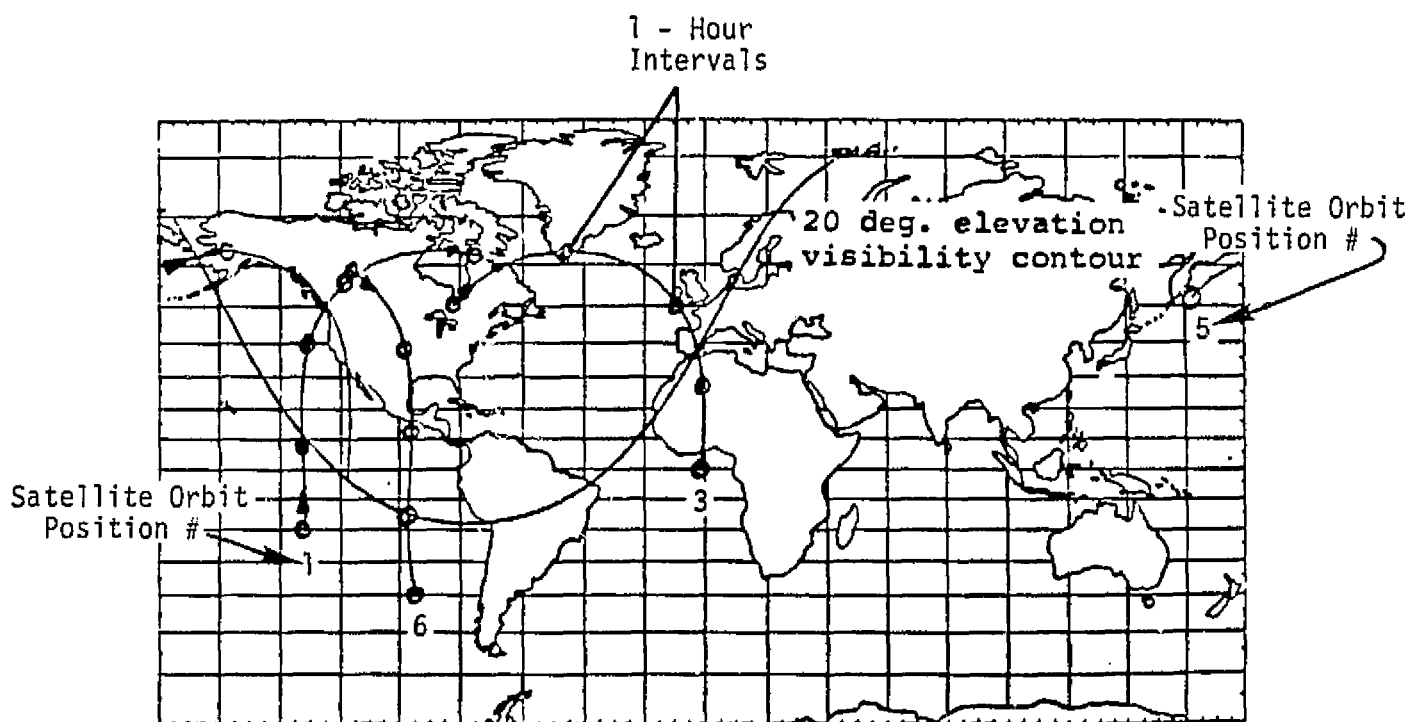

Figure 8. GPS Ground Tracks, 1600-2000 hrs GMT, 1 Jan. 1979 (20 deg. elevation visibility contour shown around Wash., D.C.)

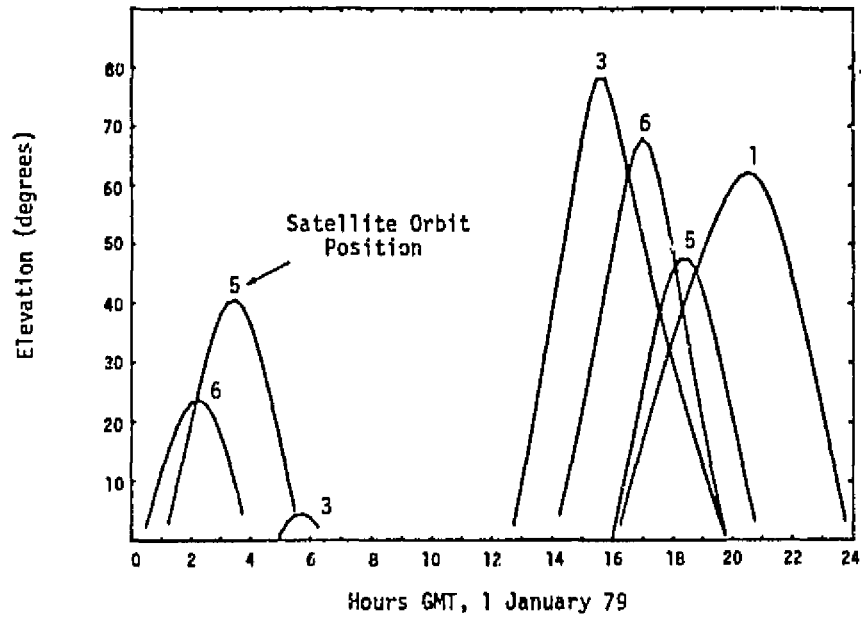

Figure 9. GPS Satellite Elevation Angles at Wash., D.C.

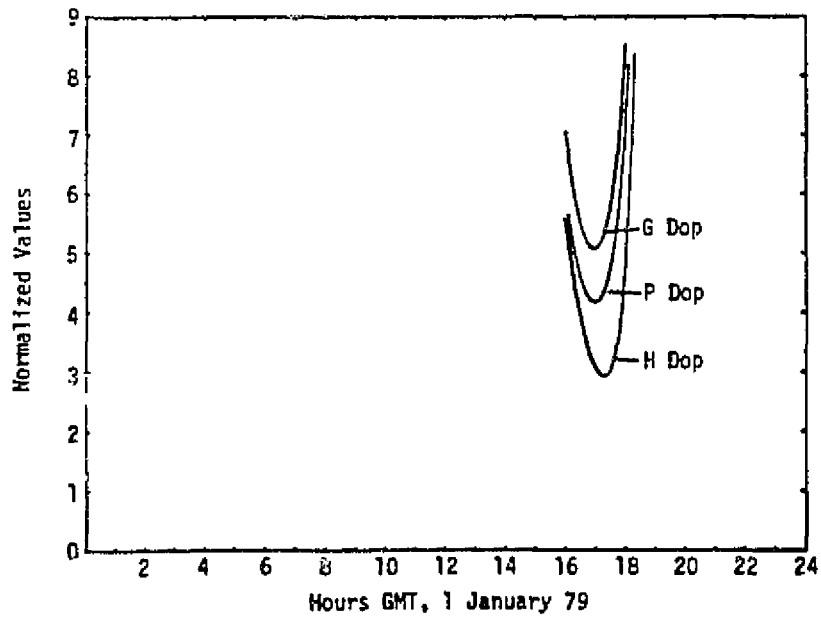

Figure 10. Dilution-of-Precision (DOP) Values at Wash., D.C.

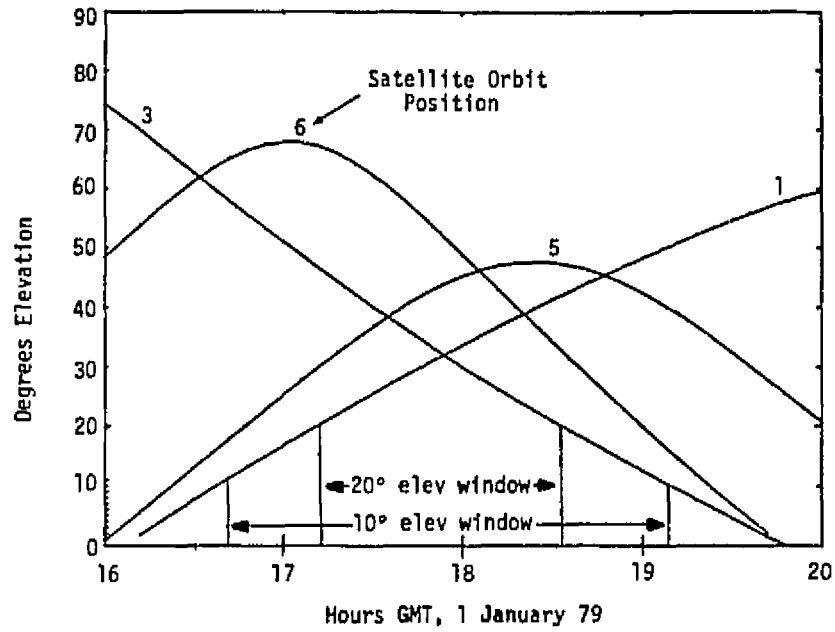

Figure 11. GPS Satellite Elevation Angles at Wash., D.C.

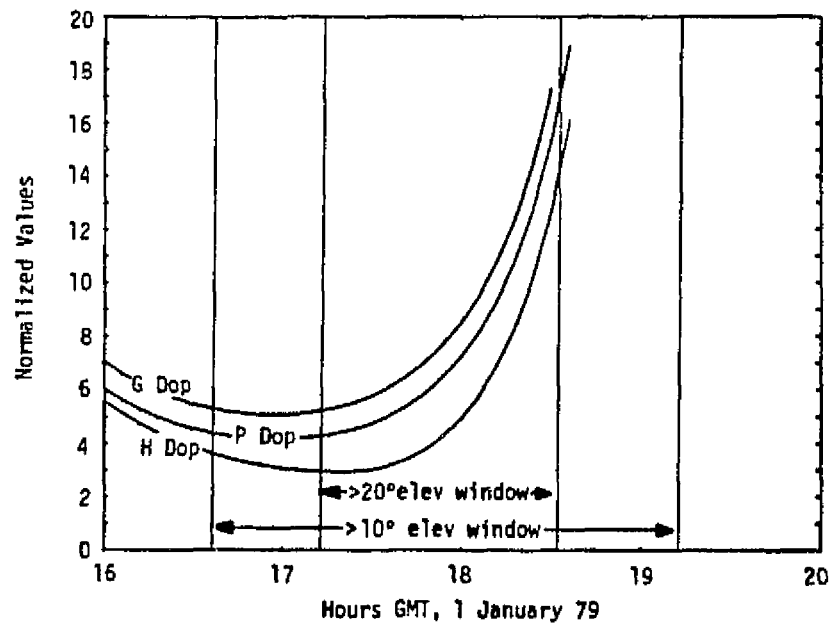

Figure 12. Dilution-of-Precision (DOP) Values at Wash., D.C.

TABLE 5
GPS SATELLITE TEST WINDOW AT WASHINGTON, D.C.*

TEST DATE				
Jan 79	Jan 80	Mar 80	Apr 80	May 80
GMT	GMT	GMT	GMT	GMT
1642 hrs	1601	1158	0952	0750
to	to	to	to	to
1906 hrs	1825	1422	1216	1014

* 10 degree elevation window

TABLE 6
GPS SATELLITES IN ORBIT AS OF JUNE 1980

<u>NAVSTAR SATELLITE #</u>	<u>GPS ORBIT POSITION #</u>
NAV 1	2
NAV 4	3
NAV 2*	4
NAV 3	6
NAV 5	1
NAV 6	5

*Has Defective Clock.

3.2 GPS REFSAT Test Block Diagram

GPS REFSAT test equipment connections and off-line data processing are shown in the form of a functional block diagram on Figure 13. The source or responsible agent is indicated for each block.*

For satellite testing, the REFSAT-aided receiver must acquire two sets of signals: a REFSAT signal containing the reference carrier and the 128 bps FSK data and signals from 4 GPS satellites. Precise earth-centered coordinates for the receiving antenna location atop the contractor's building in Falls Church, Virginia have been provided by the Defense Mapping Agency using NNS satellite doppler shift measurement techniques. The REFSAT signal will be radiated from a transmitting antenna placed within a few feet of the receiving antenna. This arrangement simulates the REFSAT RF link at such a low power level that FCC licensing requirements and possible interference to other services are avoided.

The receiver microprocessor will output approximately 100 bits of information during each 12 ms interpolation interval (nominal 8300 bps) of the receiver code correlation process. The plan is to record this data on disk for later analysis. It is planned to collect burst mode data during the first several days of satellite testing to confirm that receiver and microprocessor operation meet design goals.

Logging mode data will also be collected throughout the satellite testing period and will provide the information needed to compute receiver position. During each one-second time period corresponding to a particular REFSAT data word, the receiver microprocessor will output 66 8-bit bytes of data at 9600 baud. This data message contains measured pseudo-range values, a copy of the current REFSAT data word as decoded by the receiver, and certain microprocessor status table values for later data reduction. This data will be recorded on redundant audio recorders as discussed later.

Logging mode data will be combined with GPS navigation message data (supplied by Vandenberg Air Force Base (VAFB)) on an off-line basis for computation of receiver measured position.

The stable reference carrier needed for the REFSAT simulation is synthesized from a General Radio 1115-C Standard Frequency Oscillator (5 parts in 10^{10} per day). This reference oscillator also drives a time word generator to provide the REFSAT clock needed for accurate timing

* Government furnished equipment (GFE), Howard University (HU), Systematics General Corporation (SGC).

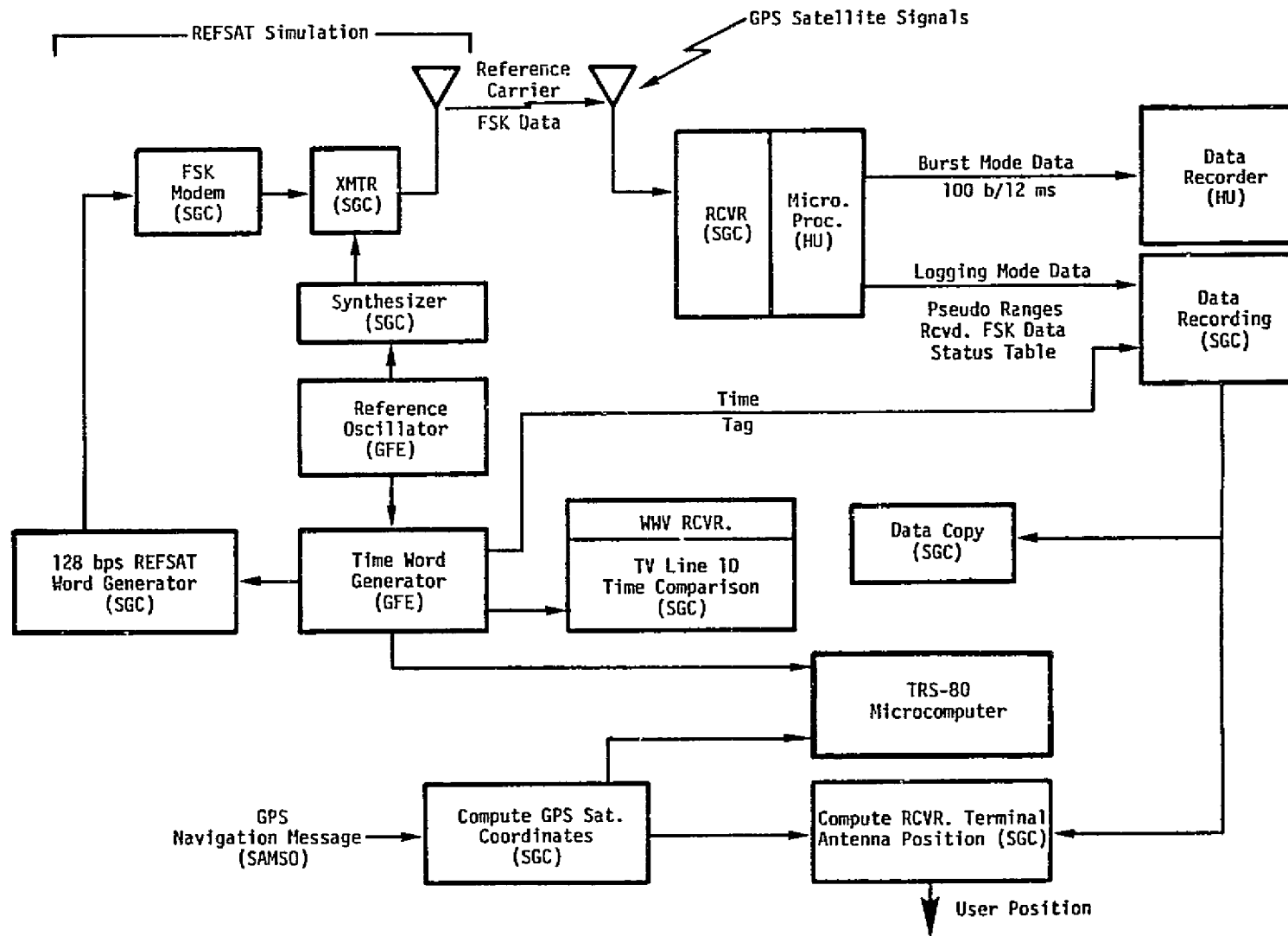

Figure 13. GPS REFSAT Test Block Diagram.

at a 1-ms rate for the REFSAT word generator. A television "line 10" time comparison system and WWV receiver allow synchronization of the REFSAT clock to the GPS time scale ($\pm 500 \mu\text{s}$ required accuracy)

A Tandy Corporation TRS-80 general purpose microcomputer performs the function of the REFSAT word generator and also aids logging mode data recording. The computer, utilizing a Z-80 microprocessor, contains a 13 kbyte (8 bit) BASIC interpreter in ROM and has editor/ assembler capability for development of machine language programming. It may be used for a number of data reduction and general housekeeping tasks incidental to receiver testing. Microcomputer interfaces with test equipment connections are shown on Figure 14.

3.2.1 REFSAT Word Generator Description

The REFSAT Word Generator has a data frame that contains four 128 bit words transmitted in synchronism with the REFSAT clock at a 128 bps rate. In addition to a time tag, each word contains:

- GPS satellite identification;
- Current position coordinates for the selected GPS satellite (contains dummy data for the test described here, since receiver position computations will be performed off-line);
- Current doppler estimates for the selected GPS satellite to allow rapid acquisition of the chosen GPS satellite signal.

An error analysis shows that doppler estimate information from satellite almanac data should be computed at one-minute intervals. Since the GPS satellite ground tracks repeat daily, the same doppler estimate information may be used on successive days, provided that the time of transmission is adjusted to take into account the difference between solar and sidereal time (see Section 3 of this document).

In order to accommodate a nominal 2.5 hour test window, 150 one-minute intervals, corresponding to 150 frames of REFSAT data, will be precomputed and placed in computer memory ($150 \times 128 \times 4/8 = 9600$ bytes required). As shown in Figure 14, the computer with knowledge of the current time word generator reading selects the proper REFSAT data frame for transmission; transfers the selected data frame to a parallel-to-serial converter on demand, one byte at a time; and inserts a current time tag as required.

The clock for the parallel-to-serial converter is derived from the Time Word Generator to insure accurate synchronization with the GPS time scale.

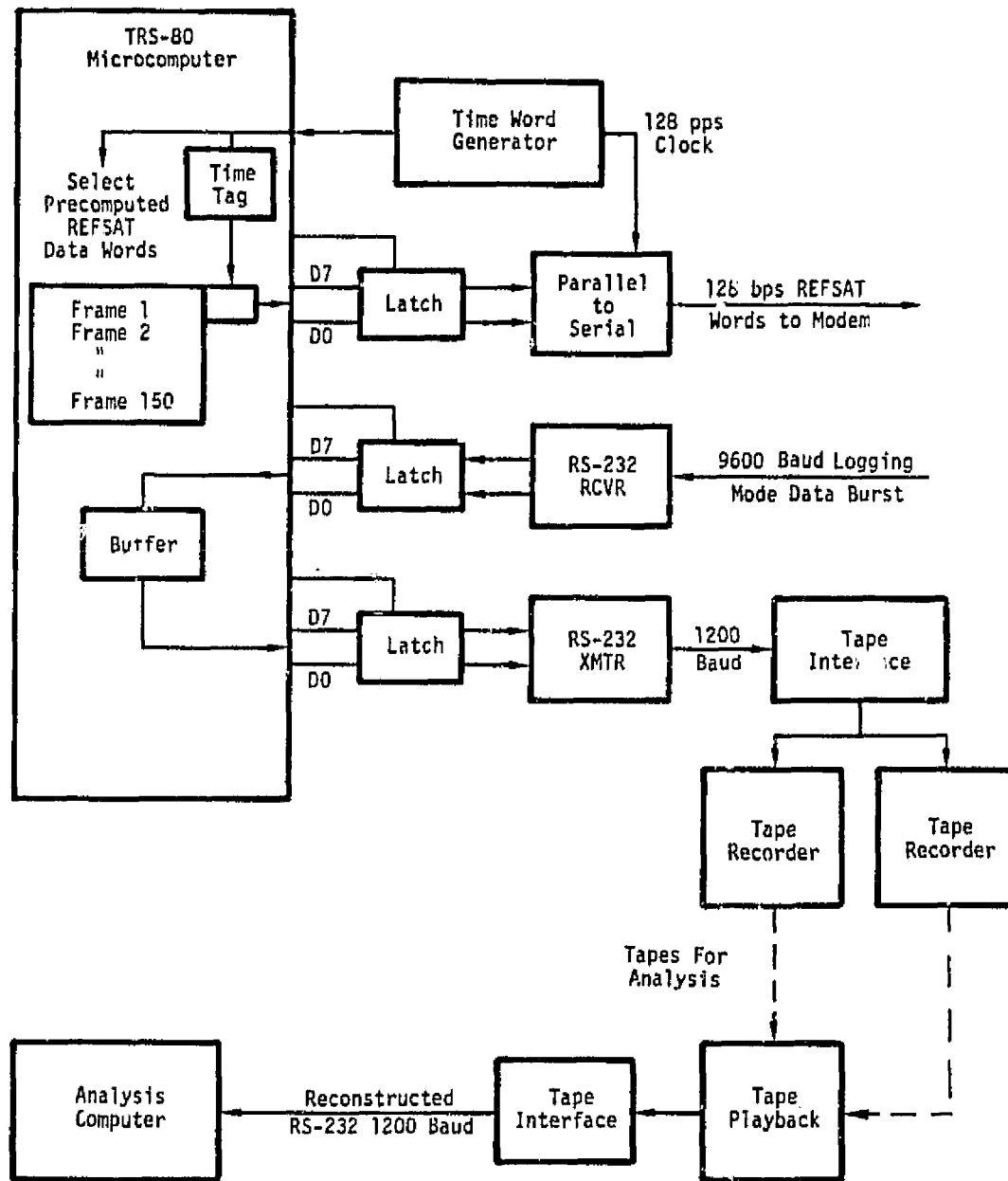

Figure 14. Microcomputer Interface to Test Equipment.

Considering the 128 bps REFSAT data transmission rate, the computer must output one byte in parallel form each 62.5 ms, allowing ample time for the computer to carry out other functions if desired.

3.2.2 Logging Mode Data Handling Description

Logging mode data (Figure 14) from the receiver microprocessor is received and converted to 8 bit parallel form in an RS-232 interface. During each nominal 70 ms data burst, successive data bytes may remain in the latch for about 1 ms, affording the computer sufficient time to service the REFSAT word generation function and move incoming logging mode data into memory. At the completion of each nominal 66 byte data burst, some 930 ms remain before the next data burst. During this time period, the computer places successive bytes in the output latch where they are converted to RS-232 asynchronous serial form. At a 1200 baud rate, the 66 bytes may be transmitted in about 550 ms, allowing ample time before the next logging mode data burst. A time tag will be inserted in outgoing data to aid identification in the data reduction process.

The "slowed down" logging mode data in RS-232 format is then used to phase-modulate an audio-frequency carrier and be recorded using redundant audio tape recorders. A tape play-back unit fitted with a tape interface will then provide a replica of the original logging mode data (with added time tag) in RS-232 format for input to the Analysis Computer.

3.2.3 Use of Computer to Aid Time Word Generator Synchronization

The computer may also be used to aid the process of synchronizing the REFSAT clock with the GPS time scale. The time word generator employed provides the capability of advancing or retarding the REFSAT clock by precisely known values. The REFSAT clock may be synchronized to the GPS time scale by:

- Advancing or retarding the time word generator for coincidence of internal 1 pps pulse with received WWV 1 pps "ticks" with the aid of an oscilloscope;
- Further advancing the time word generator to account for the computed propagation time of the WWV signal. REFSAT clock is then synchronized to UTC to within perhaps \pm several ms;
- Utilize computer to count the time interval between an arbitrary 1 pps REFSAT clock "tick" and the following "line 10" pulse obtained from local television channel 5 emissions;
- Utilize the computer along with stored time-of-coincidence (TOC) data obtained in advance from the Naval Observatory to compute the REFSAT clock error re the UTC time scale;
- The REFSAT time word generator may then be advanced or retarded to reduce the error as needed and to compensate for any differences between the UTC and GPS time scales.

3.3 Test Procedure

The following steps will be required for each day's test window:

1. Activate equipment
2. Load microcomputer with:
 - a. Test program
 - b. Current date
 - c. Precomputed REFSAT data words
 - d. Current TV line 10 TOC data
 - e. Current UTC-GPS time scale offset data
3. Check REFSAT clock synchronization and correct if required. Record clock offset and correction if any in test log.
4. Start logging mode data tape recorders.
5. Start logging mode computer program.
6. Activate REFSAT simulation transmitter and REFSAT receiver. Record test start time in test log.
7. Record pertinent observations or anomalies in test log as required.
8. Enter stop time of test in test log.
9. Secure equipment (except reference oscillator and time word generator).

4.0 CHECKOUT TEST PERFORMANCE

This section describes performance tests of the analog and analog-to-digital interface portions of the GPS/REFSAT receiver. The digital portion of the receiver (μ -processor) is not described.

The analog and interface portions of the GPS/REFSAT receiver perform the following functions:

- (1) RF amplification and frequency translation of received GPS satellite signals and the received REFSAF reference signal,
- (2) Recovery of the REFSAF signal carrier to provide the receiver's precision frequency reference,
- (3) REFSAF signal data demodulation and conversion to digital bit stream,
- (4) Doppler correction on command of the μ -processor for acquisition and tracking of GPS satellite signals,
- (5) Correlation of local PN code replicas (from the μ -processor) with those contained in the received GPS satellite signals,
- (6) Conversion of analog correlation data to digital form for feedback to the μ -processor.

4.1 RF Amplification and Frequency Translation Tests

RF amplification and frequency translation tests were performed by connecting a signal generator in place of the antenna to allow insertion of a CW signal at either the GPS satellite signal or REFSAF reference signal carrier frequencies. A spectrum analyzer was then used to measure both signal and noise levels throughout the GPS and REFSAF channels of the receiver for comparison with design values. Design performance has been achieved within expected tolerances.

The equivalent receiving system noise temperature was determined by noting the signal level output from the signal generator required to produce a given signal-to-noise ratio in a known bandwidth. An effective value of 1696 Kelvin was measured (0.7 dB greater than design value of 1434 K given in Table 1).

4.2 REFSAT Signal Carrier Recovery

The REFSAT approach allows stability requirements for the receiver master oscillator (and derived local oscillator signals) to be relaxed to 1 ppm. The REFSAT carrier recovery loop must then be capable of acquisition and tracking over a range greater than the maximum frequency uncertainty associated with the receiver master oscillator.

The capture range of the carrier recovery loop was measured by connecting a signal generator in place of the receiving antenna, adjusting the generator output to the expected received REFSAT signal level. The signal generator frequency was then varied about the REFSAT carrier frequency and the loop capture range limits measured. A range of ± 28 ppm was measured.

4.3 REFSAT Signal Data Demodulation

Demodulation of the REFSAT signal and conversion to a digital bit stream for input to the μ -processor was checked by inserting simulated signals into the data demodulator circuits.

4.4 Doppler Correction

A digital-to-analog converter and a voltage-controlled oscillator (VCO) are used for doppler correction on command from the μ -processor. A total correction range of ± 4000 Hz, in 25 Hz steps, is required to achieve an absolute frequency error of 50 Hz, or less.

After initial VCO adjustment, a slewing rate in excess of 4000 Hz per millisecond was measured. A test circuit simulated digital commands from the μ -processor. The correction range and absolute accuracy was checked periodically for several months without further circuit adjustment. A correction range in excess of ± 5000 Hz, in 25 Hz steps, with a worst-case absolute frequency error of 21 Hz, was observed.

4.5 Correlation

During normal receiver operation, correlation is achieved by applying received GPS satellite signals to one input of a double-balanced mixer and a locally-generated signal replica to the other mixer input. The mixer output, after low-pass filtering, is applied to an integrate-and-dump circuit.

The correlation process is "non-coherent" in that the carrier associated with the locally-generated replica is not coherent with the GPS satellite signal virtual carrier (The local carrier will be adjusted to within ± 25 Hz of the GPS carrier by μ -processor command to the doppler compensation circuits). "In-phase" and "quadrature" integrate-and-dump circuits then provide the required feed-back via analog-to-digital converters to the μ -processor to provide sequential acquisition and tracking of 4 selected GPS satellite signals.

The analog portions of the receiver associated with the correlation process were tested by connecting a CW signal generator in place of the antenna. The signal generator output was adjusted to the expected GPS satellite signal levels. The signal generator frequency was set to the nominal (zero doppler) GPS signal frequency. Under these conditions, both the simulated GPS signal and the locally-generated replica applied to the correlation mixers were CW signals. The correlator output then simulates that which would result from perfect alignment of the received and locally-generated PN codes. An examination of the resultant signals within the "in-phase" and "quadrature" integrate-and-dump circuits with a dual-channel oscilloscope showed satisfactory correlation performance.

4.6 Conversion of Analog Correlation Data to Digital Form

The analog outputs of the integrate-and-dump circuits described in the previous section are converted to digital form for input to the μ -processor. Operation of the analog-to-digital converters was tested by applying a variable DC level to the converter input within the range of levels observed in the previous section. Digital output values correlated with DC input levels within design limits.